

OPERATING INSTRUCTIONS

Tomato Witch™ Model No. 919 Series



Prince Castle's Tomato Witch is the ideal tomato slicing system. The Tomato Witch provides the safety and strength needed for superior results. It uniformly slices tomatoes without manual scoring, and is a necessity for portion control.

SPECIFICATION

919 Series

Length	15" (38.1 cm)
Width	8" (20.3 cm)
Height	8½" (61.6 cm)
Shipping Weight	13 lbs.(5.9 kg.)

Dimensions

Model No.

Model No.	Number Of Blades
919-AAS ¾" Slice (.477 cm)	14
919-ABS ¼" Slice (.635 cm)	10
919-ACS ⅜" Slice (.935 cm)	7
919-ADS ⅞" Slice (.553 cm)	12

Number Of Blades

TABLE OF CONTENTS

PAGE

Installation	2
Operating	2
Cleaning	3
Maintenance	3
Blades	4
Parts List.....	5

LIMITED WARRANTY

This Product is warranted to be free from defects in material and / or workmanship for a period of (2) years from date of original installation not to exceed 30 months from date of shipment from our factory, **with the exception of blades**. Blades are warranted to be free from defects at time of delivery only.

Any component which proves to be faulty in material and/or workmanship will be replaced or repaired (at the option of Prince Castle, Inc.) without cost to the customer for parts or labor.

This warranty is subject to the following exceptions/ conditions:

- Use of any non-genuine Prince Castle parts voids this warranty. All genuine Prince Castle replacement spare parts are warranted for ninety (90) days from date of purchase.
- This equipment is portable; charges for on location service (e.g., trip charges, mileage) are not included in the provisions of this warranty.
- Damage caused by carelessness, neglect, and/or abuse (e.g., dropping, tampering or altering parts), equipment damaged in shipment, by fire, flood or an act of God is not covered under this warranty.

INSTALLATION

- After you have removed the slicer from the carton, inspect the unit for signs of damage. If there is damage to the unit:
 - Notify carrier within 24 hours after delivery.
 - Save carton and packing materials for inspection purposes.
 - Contact your local dealer, or if purchased directly, the Prince Castle Customer Sales Department at 1-800-722-7853 to arrange for a replacement to be sent.
- Verify that all parts have been received.

OPERATION



CAUTION: This slicer is designed to slice tomatoes only. Using it on other products will damage the slicer.

- Check tomatoes for proper condition (no bruises, scarring or mold) and color (5-6 color grade).
- Place tomatoes to be sliced in a clean, sanitized colander. Rinse with cold water and drain.
- Place tomato slicer on a clean, sanitized food prep table. The back sink should not be used as a slicing area.
- Before slicing the first tomato of the day, lubricate guide rods with Petro Gel/Taylor Lube/Haynes Lubri-Film (HCS).



CAUTION: Keep fingers away from blades. They are extremely sharp.

- Before using the slicer, check if blades are tight. Loose blades may bow as product passes through, resulting in damage to both the pusher head and the blades. Prior to each use, recheck blades for proper tension. Alternately hand-tighten the blade tensioning screws (Items 20 & 21 on the exploded view).
- Place a clean, sanitized pan under slicer at the end opposite the handle to collect tomato slices.

IMPORTANT: If rubber feet are missing slicer will slide during cutting process. Replace with part #919-18.

- Grasp handle, and pull back as far as possible.
- Insert tomato into pusher with the core side down. See figure 1.

figure 1



- Push handle with a quick, firm stroke until the pusher stops. The tomato should be completely sliced.
- Remove tomatoes.
- Discard end pieces and any slices with green core centers (stem) showing.
- Clean and sanitize slicer and food prep table.

TROUBLESHOOTING CHART

PROBLEM	CAUSE	SOLUTION
Pusher handle is hard to push or pusher head fingers hit blades.	Friction on guide rods. Blades are loose.	Lubricate guide rods. Hand tighten blades (See blades section on page 4).
Excessive wobble in carrier plate.	Bearing block screws are loose. Bearing blocks are worn out.	Tighten the (4) bearing block screws located under the slicer. (See daily maintenance tips) Replace bearing blocks.
Tomato will not go all the way through blades.	Blades are dull. Blades are loose.	Replace blades. (See exploded view and parts list for correct part number) Hand tighten blade tensioning knobs.
Tomato is hanging up on left side of blades.	Blades are dull. Blades are not tightened flat against bridge on left side.	Replace blades. Re-tighten the (2) slotted hex head screws, until the blade block is flat against the bridge on the left side.

CLEANING

1. Spray the blade assembly and pusher head with hot water to remove tomato residue.
2. Brush the pusher head and blades (from the back side) with the nylon pot brush and a hot soapy water.
3. Rinse by spraying with hot water.
4. Let air dry.

NON-SCHEDULED MAINTENANCE

LUBRICATE GUIDE RODS

Tools Required: Petro Gel/Taylor Lube/Haynes Lubri Film (HCS)

- Generously apply Petro Gel/Taylor Lube/Haynes Lubri Film (HCS) to the guide rods. (See Figure 3)

TIGHTEN BEARING BLOCK SCREWS

Tools Required: $\frac{7}{16}$ " (6 mm) Wrench

- Using a $\frac{7}{16}$ " (6 mm) wrench tighten the screws on the bridge. Hand tighten the thumbscrews on the bearing blocks located under the base. See figure 2.

figure 2

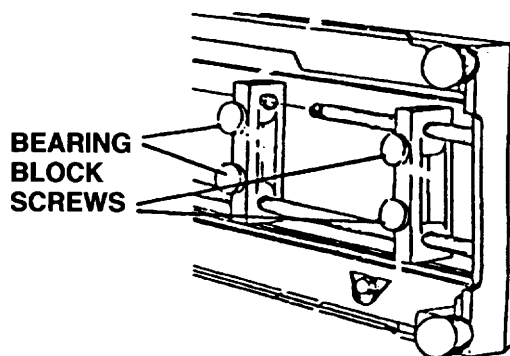

TIGHTEN HANDLE SCREW

Tools Required: $\frac{7}{16}$ " (6 mm) Wrench

- Using a $\frac{7}{16}$ " wrench tighten the handle screw, located under the carrier plate. See figure 3.

figure 3

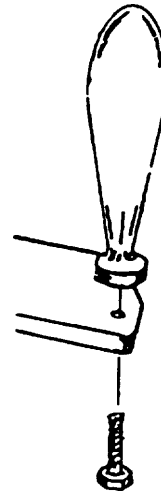

TIGHTEN BLADE GUARD SCREWS

Tools Required: Phillips Screwdriver

- Using a Phillips screwdriver tighten all 3 screws on the blade guard (A). See Figure 5)

TIGHTEN BLADE SCREWS

- Check the blades for tightness. Alternating the tensioning knob.



CAUTION: Do not over-tighten.

DAILY MAINTENANCE

PRIOR TO SLICING TOMATOES

1. Ensure guide rods are lubricated.
2. Check the (4) bearing block screws for tightness.
3. Check handle screw for tightness.
4. Check for proper blade tension by checking blade adjustment knobs. See page 7.
5. Check for proper alignment of pusher head and blades by pushing the pusher head through the blades without a tomato.

AFTER SLICING TOMATOES

1. Clean slicer.
2. Store slicer with pusher head passed through blades as far forward as possible.

REPLACING BLADES

Tools Required □ Flat blade screwdriver

1. Pull pusher head handle as far back as possible. Remove and discard old blades and hardware.
2. Carefully install new blades on unit.

IMPORTANT: Drawings show view from behind handle.

IMPORTANT: Check blades for tightness prior to use. Loose blades will bow as tomato passes through causing damage to the blades and the pusher head. To ensure blades are tightened properly, alternately tighten adjustment knobs.

CLEANING BLADES

Always clean blades after each use. Food acids will dull and corrode blades. Clean between blades using a pot cleaning brush, and spray with hot water. Make sure to remove any excess tomato skin. Let unit air dry.

Install this side first. Make sure blade block is flush against bridge.

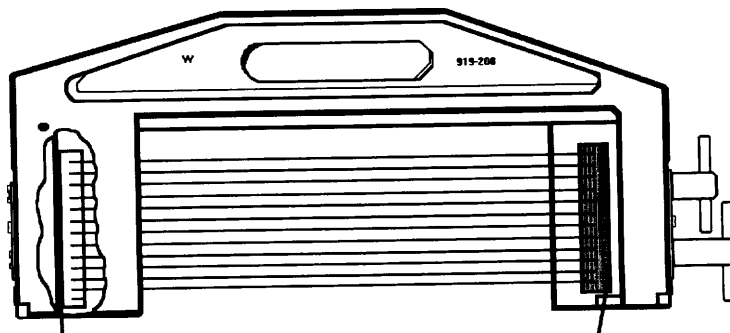
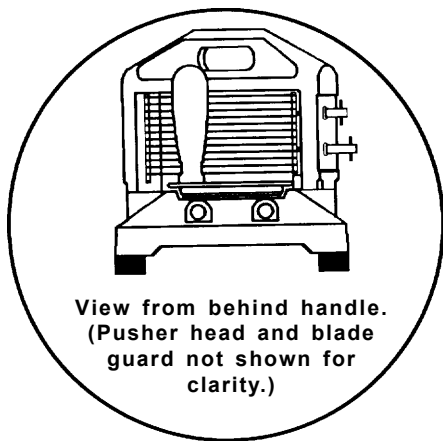
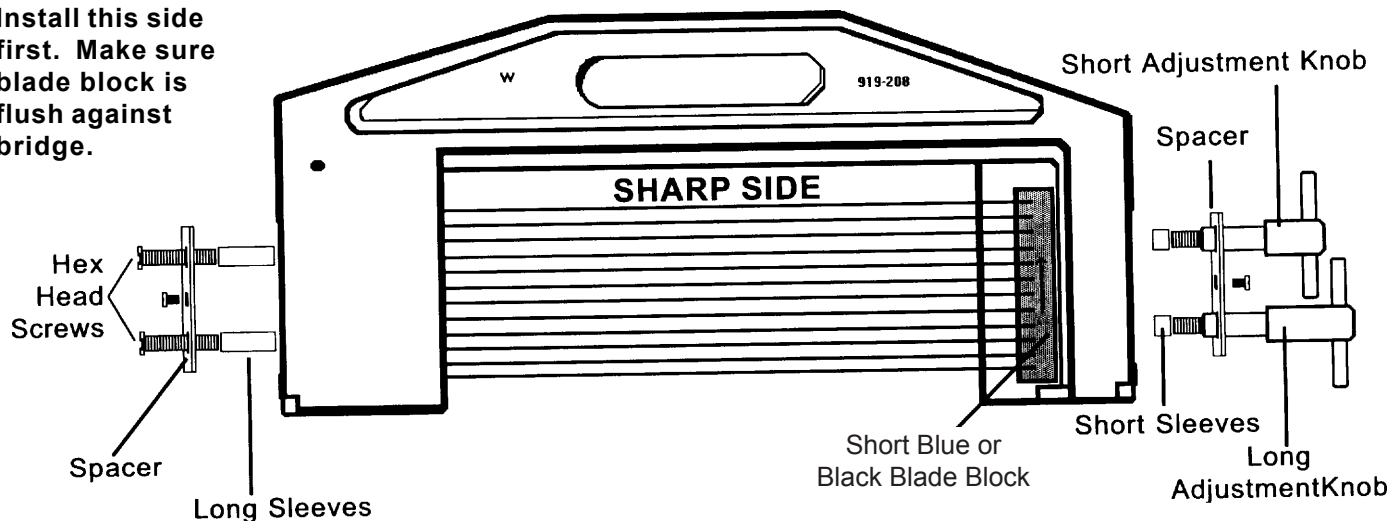

When mounted correctly, there will be a 1/4" gap between blade block and bridge on this side.

EXPLODED VIEW

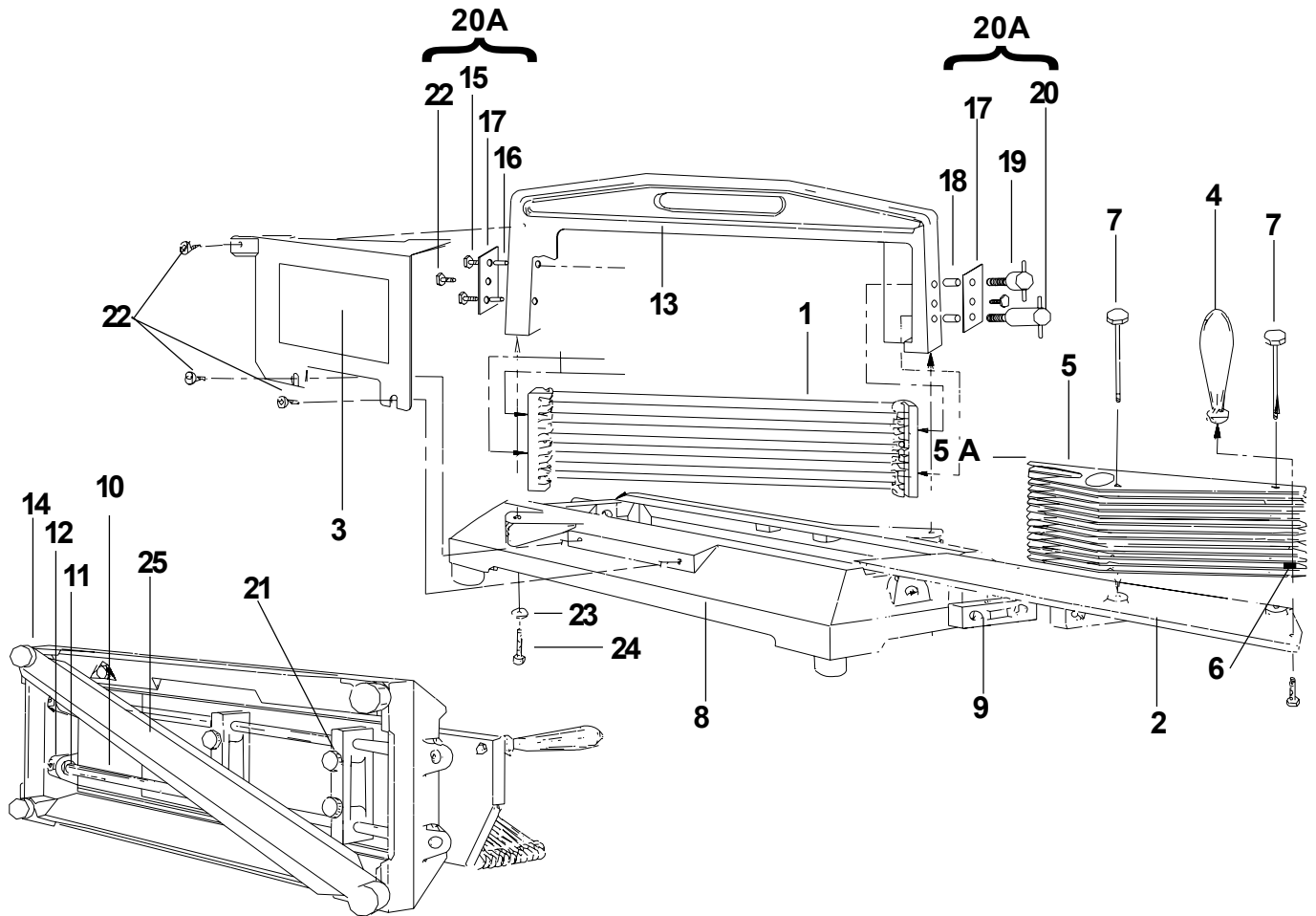

PARTS LIST

ITEM	PART	DESCRIPTION	ITEM	PART	DESCRIPTION
1	919-187A	Blade Assy $\frac{3}{16}$ " (4.7mm)	7	919-19S	Pusher Head Mounting Bolts (Pkg of 2)
	919-188A	Blade Assy $\frac{1}{4}$ " (6.4mm)	8	919-224	Base (Incl. Items 9,10,14 & 25)
	919-189A	Blade Assy $\frac{3}{8}$ " (9.5mm)	9	919-121S	Bearing Block w/Mounting Screws (Pkg of 2)
	919-191A	Blade Assy $\frac{7}{32}$ " (5.5mm)	10	919-14	Guide Rod w/Cushions and Set Screw
2	919-142S	Carrier Plate $\frac{3}{16}$ " (4.7mm)	11	919-17S	Cushions (Pkg of 4)
	919-144S	Carrier Plate $\frac{1}{4}$ " (6.4mm)	12	76-202	Set Screw ($\frac{1}{4}$ -20 x 1- $\frac{1}{4}$)
	919-142S	Carrier Plate $\frac{3}{8}$ " (9.5mm)	13	919-80S	Bridge with Mounting Screws
	919-143S	Carrier Plate $\frac{7}{32}$ " (5.5mm)	14	919-18	Feet (Pkg of 4)
3	919-125S	Safety Guard with Screws	15	76-656	Slotted Hex Head Screw
4	919-114	Handle with Mounting Screws	16	919-186	Sleeve
5	919-192	Pusher Head Assy $\frac{3}{16}$ " (4.7mm)	17	919-203	Washer PLate
	919-194	Pusher Head Assy $\frac{1}{4}$ " (6.4mm)	18	919-178	Tensioning Knob Sleeves
	919-192	Pusher Head Assy $\frac{3}{8}$ " (9.5mm)	19	919-184	Upper Blade Tensioning Knob
	919-193	Pusher Head Assy $\frac{3}{16}$ " (5.5mm)	20	919-185	Lower Blade Tensioning Knob
5A	919-177S	Pusher Head Plate w/Spacers	20A	919-184S	Blade Assy. Hardware Kit includes items: 15, 16, 17, 18, 19, 20, & 22
6	919-126S	Spacer, White, $\frac{3}{16}$ " & $\frac{3}{8}$ " (4.7mm) (Pkg of 12)	21	76-593S	ScREW with Knob (Pkg of 4)
	919-128S	Spacer, Gray, $\frac{1}{4}$ " (6.4mm) (Pkg of 12)	22	76-238	Phillips Pan Head Screw
	919-127S	Spacer, Black, $\frac{7}{32}$ " (5.5mm) (Pkg of 12)	23	79-123	Lock Washer $\frac{1}{4}$ "
			24	76-485S	Screw Socket Hd ($\frac{1}{4}$ -20 x 1- $\frac{1}{8}$) (Pkg of 6)
			25	919-205	Bracket Stiffener