

Operation Manual

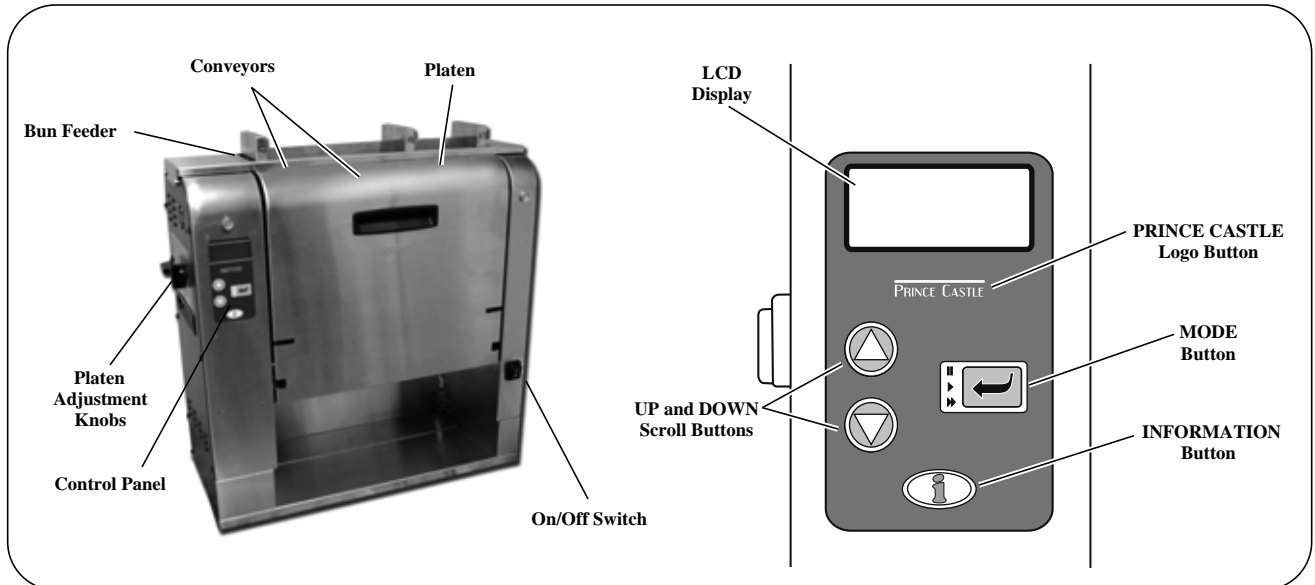

Dual Continuous Feed Toaster DCFT-JB

Product Identification



LIMITED WARRANTY

This product is warranted to be free from defects in material and/or workmanship for a period of one (1) year from date of original installation, not to exceed 18 months from date of shipment from our factory. Any part or component which proves to be faulty in material and/or workmanship within the warranty period will be replaced or repaired (at the option of Prince Castle, Inc.) without cost to the customer for parts or labor.

This warranty is subject to the following exceptions/conditions:

- Use of any non-genuine Prince Castle parts voids this warranty and all work must be performed by an authorized Prince Castle Service Agent.
- All labor shall be performed during regular work hours. Overtime premium will not be covered.
- Travel charges are limited to 100 miles (200 kilometers) round trip, 2 hours travel time, one trip per repair.
- Damage caused by carelessness, neglect, and/or abuse (e.g., using wrong current, dropping, tampering with or altering electrical components, or improper cleaning) is not covered.
- Equipment damaged in shipment, by fire, flood or an act of God is not covered.
- Damage to non-stick coated surfaces is not covered by this warranty.

TABLE OF CONTENTS

Product Identification	1
Safety Information	2
Important	2
Electrical Specifications	2
Installation	2
Operation	3
Management Programming	4
Programming Diagram	6
Daily Planned Maintenance	7
Troubleshooting	9
Exploded Views and Parts Lists	10
Wiring Diagram	11



355 East Kehoe Blvd. • Carol Stream, IL 60188 USA
Telephone: 630-462-8800 • Toll Free: 1-800-PCASTLE
Fax: 630-462-1460 • www.princecastle.com



Safety Information

WARNING

Indicates information important to the proper operation of the unit. Failure to observe may result in damage to the equipment and/or severe bodily injury or death.

CAUTION

Indicates information important to the operation of the unit. Failure to observe may result in damage to the equipment.

Important

Prince Castle reserves the right to change specifications and product design without notice. Such revisions do not entitle the buyer to corresponding changes, improvements, additions or replacements for previously purchased equipment.

Electrical Specifications

208/240V, 2700/3600W, 50/60 Hz

Installation

- 1 Unpack and inspect.** Remove the unit from the carton and inspect for signs of damage. If there is damage to the unit:
 - Notify the carrier within 24 hours of delivery.
 - Save carton and packaging materials for inspection purposes.
 - Contact your local dealer, or if purchased directly, the Prince Castle Sales Department at 1-800-722-7853 or 630-462-8800 to arrange for a replacement unit.

- 2 Verify parts.** Verify that all parts have been received:
 - Dual Continuous Feed Toaster with two conveyors.
 - Release Sheet Kit.
 - Conveyor adjustment tool.

- 3 Place toaster on flat surface.** Remove blue and/or white protective covering.

- 4 Remove packing.** Remove the cardboard spacer holding the conveyors up for shipping.

- 5 Open conveyors.** Lift each conveyor up and out. Set conveyors down and remove all cardboard and styrofoam from the conveyors and from the interior of the unit.

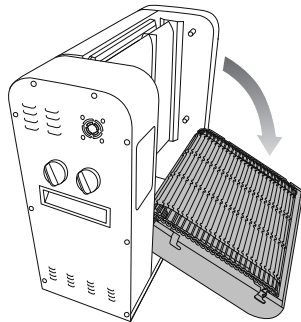

- 6 Install release sheets.** Place Teflon® release sheets over the platen.

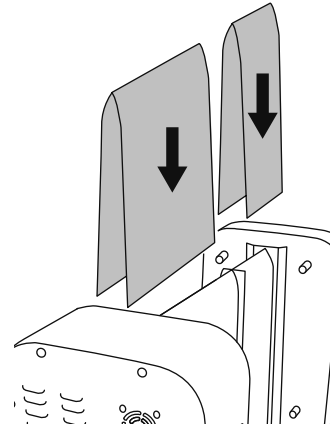

- 7 Close conveyors.** Lift one conveyor, lining up its top mounting guides with the top conveyor mounting pins on the unit. Slide the conveyor in and down until it is securely in place. Repeat with the other conveyor.

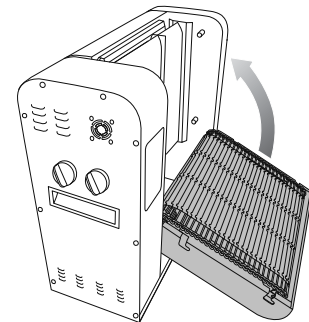

- 8 Plug unit in.** Plug unit into a grounded receptacle with a matching plug configuration.

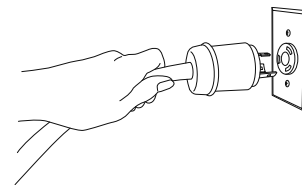

Operation

1 Turn unit ON. Turn the On/Off switch located opposite the display panel to ON. The Prince Castle DCFT screen will appear in the LCD display for 3 seconds.

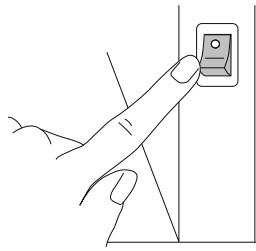

2 Wait through Warm-Up. During warm-up, the LCD display will read "STATUS" and "WARMING...". Warm-Up time is about 10-15 minutes.

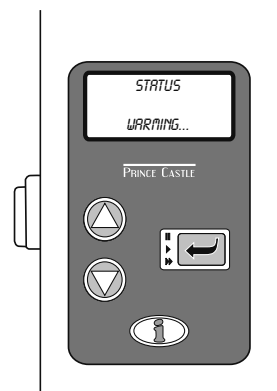

3 **WARNING**
BURN/ELECTRICAL SHOCK HAZARD! Platen sections are **HOT** and can cause severe burns or severe shock. Keep hands and objects out of the toaster unit! Failure to exercise caution may result in serious injury! Turn the unit off, unplug it and let it cool down completely before touching or working on internal apparatus.

Watch for READY status. When ready temperature is reached, the LCD display will read "STATUS" and "READY".

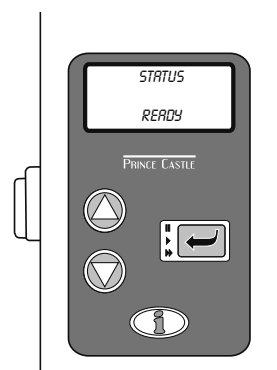

4 Observe conveyor. If conveyor motion is not smooth or is not moving, call for service.

5 View temperatures, if desired. Pressing the INFORMATION button once will display the left and right platen actual temperatures. Pressing a second time will return the LCD display to the READY screen.

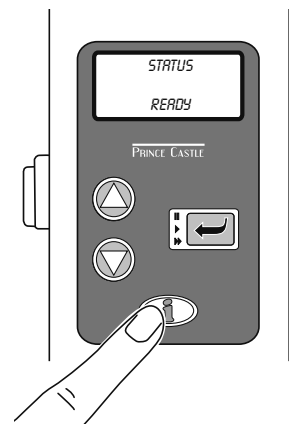

6 Choose the platen adjustments. Dial the two front platen adjustment knobs for the product part (Regular Crown, etc.) that you will be toasting in the front of the unit. Dial the two rear platen adjustment knobs for the product part (Regular Heel, etc.) that you will be toasting in the rear of the unit.

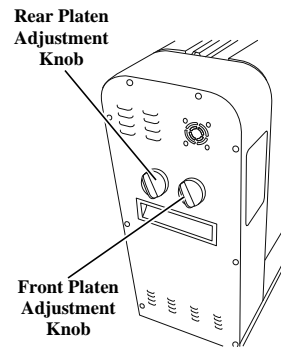

7 Begin continuous feeding. Feed product into top of DCFT, sending the correct product parts down the front and rear of the unit. The sides to be toasted should face the platen. Toasted product will exit at the base of the DCFT.

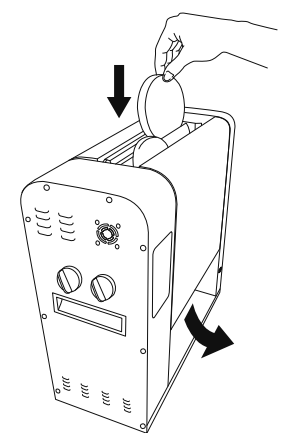

Management Programming

1

Enter program screens. Press and hold the PRINCE CASTLE logo button for 6 seconds. The PROGRAMMING VERSION screen will appear in the LCD display for 10 seconds. From the PROGRAMMING VERSION screen, you may:

- A. Press the DOWN scroll button once to choose Fahrenheit or Celsius.
- B. Press the DOWN scroll button twice to adjust temperature.
- C. Press the DOWN scroll button three times to change language.
- D. Press the PRINCE CASTLE logo button or leave the controls inactive for 10 seconds to exit programming.

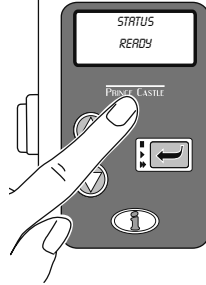

2

Choose Fahrenheit or Celsius. From the PROGRAMMING VERSION screen, press the DOWN scroll button once. From the SELECT F/C screen that appears, press the MODE button.

- A. From the SET F/C screen that appears, use the UP and DOWN scroll buttons to select TEMP = F (Fahrenheit) or TEMP = C (Celsius).

- B. Accept the new scale by pressing the MODE button to return to the SELECT F/C screen. *NOTE: To return without accepting the new setting, press the PRINCE CASTLE logo button.*

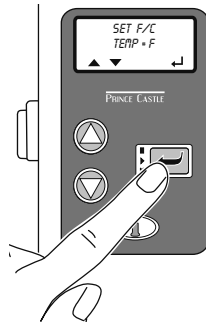
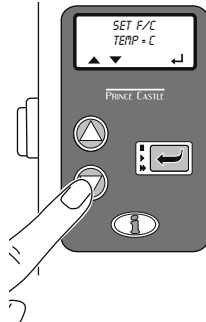
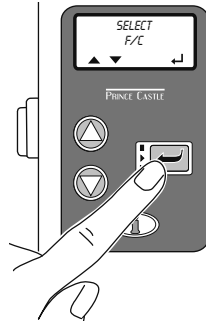

3

Adjust set point temperatures. From the SELECT F/C screen, press the DOWN scroll button. From the SELECT PLATEN TEMPERATURES screen, press the mode button.

- A. From the SET RIGHT screen that appears, adjust the right platen set point temperature using the UP and DOWN scroll buttons.

- B. Accept the new right platen setting by pressing the MODE button, which will bring the SET LEFT screen. *NOTE: To cancel without accepting the new setting, press the PRINCE CASTLE logo button to return to the SELECT PLATEN TEMPERATURES screen.*

- C. From the SET LEFT screen, adjust the left platen set point temperature using the UP and DOWN scroll buttons.

- D. Accept the new left platen setting by pressing the MODE button to return to the SELECT PLATEN TEMPERATURES screen. *NOTE: To return without accepting the new setting, press the PRINCE CASTLE logo button.*

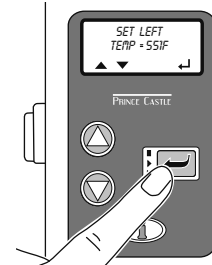
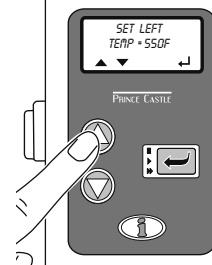
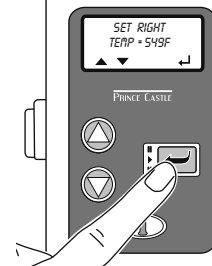
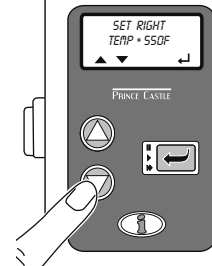
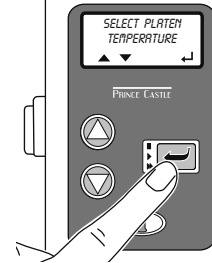

Management Programming (continued)

4 **Change language.** From the SELECT PLATEN TEMPERATURE screen, press the DOWN scroll button. From the SELECT LANGUAGE screen, press the MODE button.

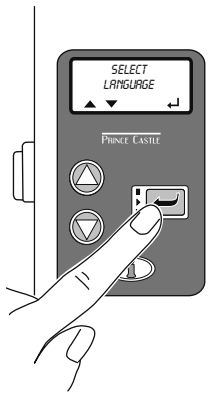

A. From the LANGUAGE screen that appears, use the UP and DOWN scroll buttons to select a different language.

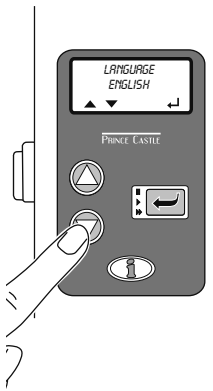

B. Accept the new language by pressing the MODE button to return to the SELECT LANGUAGE screen. *NOTE: To return without accepting the new setting, press the PRINCE CASTLE logo button.*

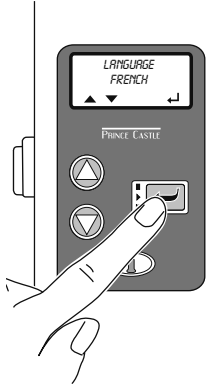

5 **Exit programming.** Press the PRINCE CASTLE logo button from the SELECT F/C, SELECT PLATEN TEMPERATURE or SELECT LANGUAGE screen or leave the controls inactive for 10 seconds.

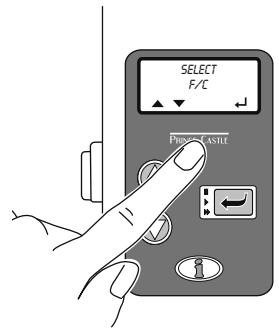

Temperature	Factory Presets	New Setting
Right Side of Platen	500°F	
Left Side of Platen	500°F	

Programming Diagram

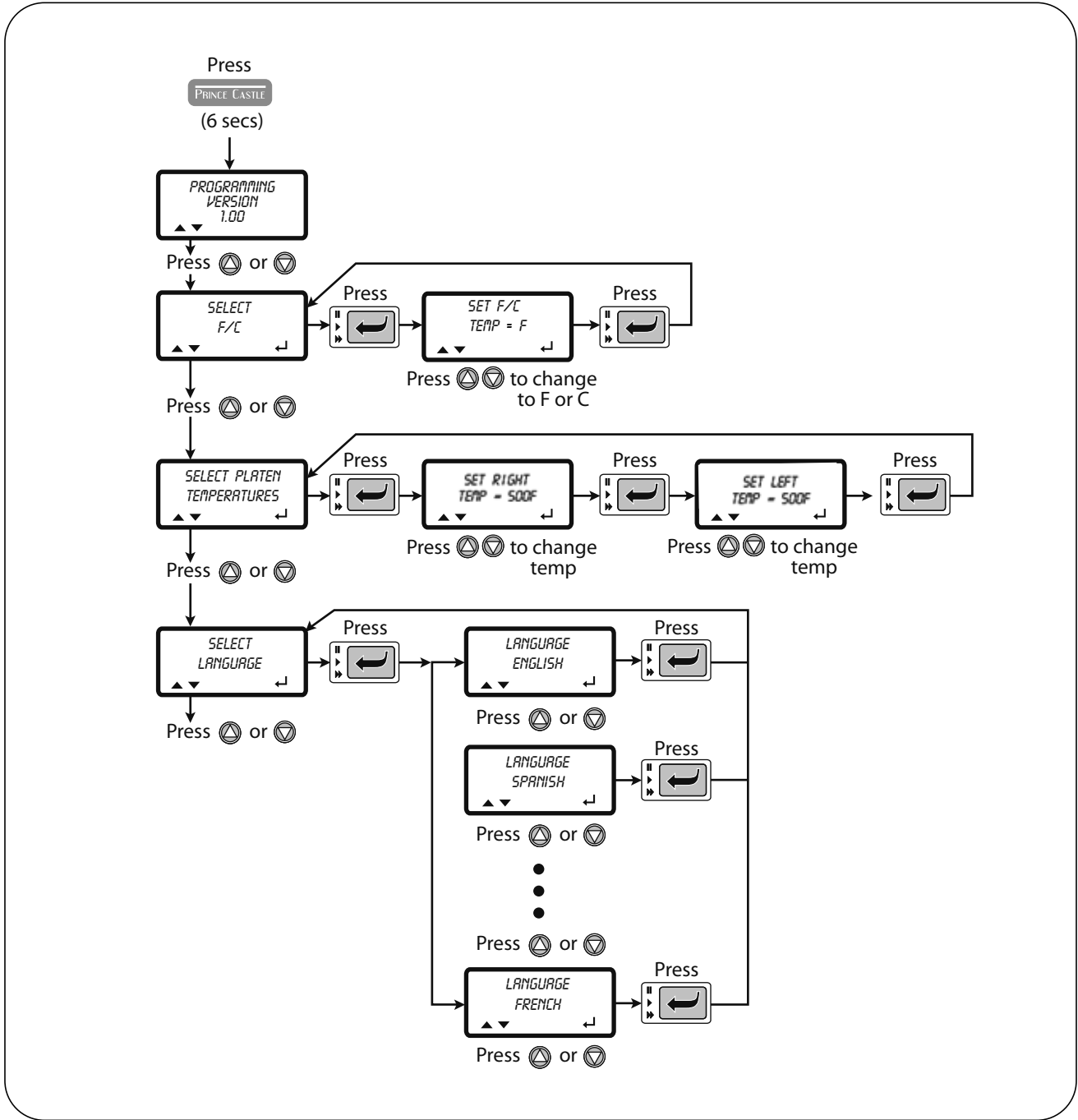

Daily Planned Maintenance

⚠ WARNING

BURN/ELECTRICAL SHOCK HAZARD! Platen sections are **HOT** and can cause severe burns or severe shock. Keep hands and objects out of the toaster unit! Failure to exercise caution may result in serious injury! Turn the unit off, unplug it and let it cool down completely before touching or working on internal apparatus.

⚠ WARNING

If the supply cord is damaged, it must be replaced by the manufacturer, its service agent, or similarly qualified person to avoid a hazard.

⚠ CAUTION

Do not immerse toaster in water. Do not clean with a water hose or jet spray. Do not use abrasive cleaners, pads or tools on the platen or the release sheet. Failure to exercise caution will result in damage to the unit and will not be covered by warranty.

- 1** **Gather cleaning materials.** You will need a clean, damp cloth, soft bristle brush, neoprene gloves, lukewarm soap and water, and non-abrasive cleaner.

- 2** **Turn DCFT OFF.** Turn the On/Off switch located opposite the display panel to OFF.

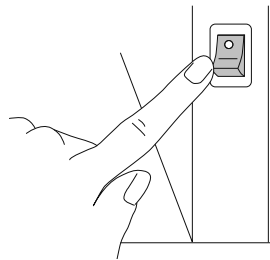

- 3** **Unplug and let cool.** Allow platen to cool for 60 minutes before cleaning.

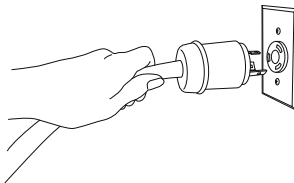

- 4** **Open conveyors.** Lift each conveyor up, out and set down in open position.

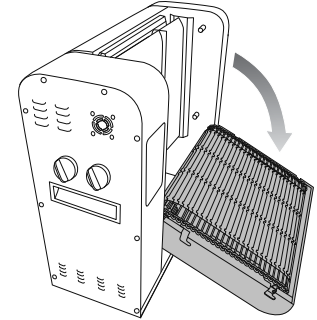

- 5** **Remove the release sheets.** Lay the release sheets on a flat surface.

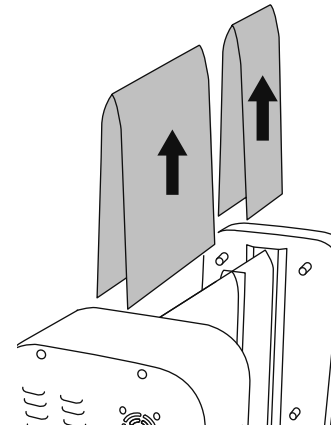

- 6** **Clean the conveyors.** Put on neoprene gloves. Wipe the conveyors with a damp cloth. Use a soft bristle brush as necessary.

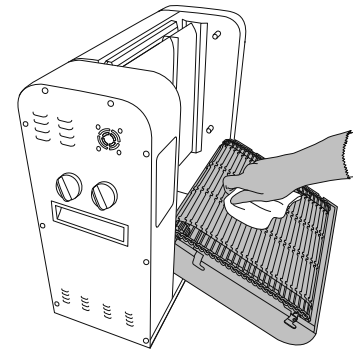

Daily Planned Maintenance (continued)

7 Clean the release sheets. Dampen a clean cloth with lukewarm soap and water. Wipe down both sides of the release sheets, making sure all built-up sugar is removed. Allow to air dry. *NOTE: Rotate sheets daily for longer life. Depending on volume of product toasted, sheets should be replaced every 4 to 6 weeks.*

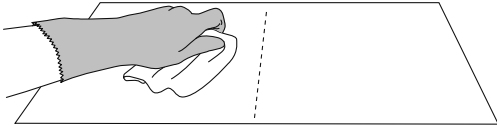

9 Clean outside of the DCFT. Dampen a clean cloth with lukewarm soap and water. Wipe down the outside of the entire DCFT. Wipe down the entire DCFT again with a fresh clean, sanitized towel.

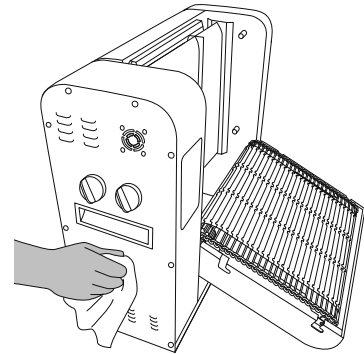

8 Clean the platen surface. Use a damp cloth to remove any built-up sugar on the surface.

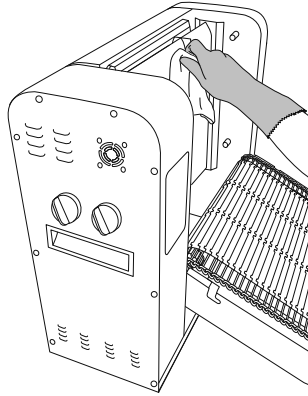

10 Reassemble the unit.

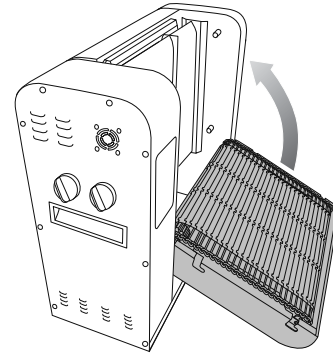

Troubleshooting



**BURN/ELECTRICAL SHOCK HAZARD! Platen sections are HOT and can cause severe burns or severe shock.
Keep hands and objects out of the toaster unit! Failure to exercise caution may result in serious injury!
Turn the unit off, unplug it and let it cool down completely before touching or working on internal apparatus.**

PROBLEM	POSSIBLE CAUSE	SOLUTION
Unit will not heat up.	No power to unit.	Ensure power cord is connected to proper receptacle.
	Inoperable power cord.	Replace power cord.
	Loose connection on power switch.	Tighten power switch connections.
	Inoperable power switch.	Replace power switch.
	High limit switch tripped.	Reset high limit switch.
	Inoperable thermostat.	Replace thermostat.
	Inoperable platen.	Replace platen.
Unit heats up, but the conveyor does not run.	Loose motor switch connection.	Tighten motor switch connection.
	Inoperable motor.	Replace motor.
	Inoperable motor switch.	Replace motor switch.
	Stripped drive gear.	Replace drive gear.
	Loose chain sprockets.	Adjust and tighten sprockets.
Unit under- and over-heats (does not respond to programming).	Check temperature setting.	Adjust temperature set point setting. See Management Programming.
	Inoperable thermostat.	Replace thermostat.
Buns under or over done.	Check platen adjustment. (See Operation.)	Move platen adjustment knobs to the correct product part setting.
	Check platen temperature. (From READY screen, pressing the INFORMATION button once will display the left and right platen actual temperatures.)	Adjust temperature set point setting. See Management Programming.
Conveyor motion appears jerky or a "skipping" sound can be heard.	Gears may be out of alignment.	Call for service.

Dual Continuous Feed Toaster DCFT-JB

Exploded View and Parts List

No.	Part No.	Description
1	526-073S	Membrane Switch w/Overlay
2	526-021S	Display Board
3	526-201S	Main Board
4	85-144-24S	Power Supply Board
5	526-025S	Motor
6	526-023S	Fan (qty of 2)
7	526-032S	Handle (qty of 2)
8	78-233S	Power Switch
9	526-362S	Platen
10	65-058S	SS Relay 50A
11	65-064S	Power Relay
12	77-090S	Terminal Block
13	525-022S	Crown Conveyor
14	525-024S	Heel Conveyor
15	526-295S	Gear (qty of 2)

No.	Part No.	Description
16	72-446S	Power Cord
17	526-221S	Knobs (qty of 2)
18	526-279S	Teflon Sheets
19	526-281S	Hi Limit
20	77-092-03S	Terminal Block
21	526-185S	Minor Side Overlay
22	526-617S	In-Feed
23	526-606S	Back Plate
*	526-022S	Probe
*	526-184S	Major Side Overlay
*	526-392S	Idler Sprocket (qty of 2)
*	526-081S	Drive Sprocket (qty of 3)
*	526-614S	Rope Heater, Landing Zone

* Not Shown

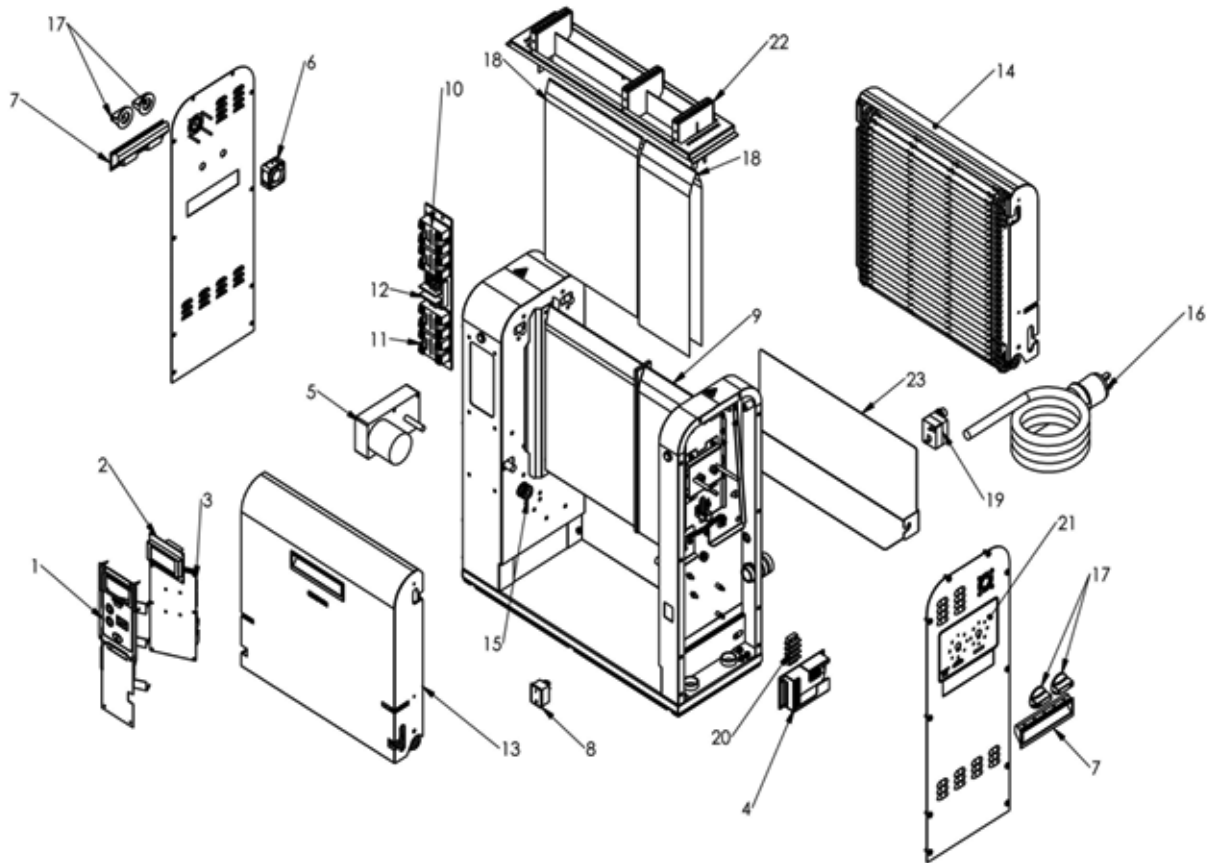

Wiring Diagram

