

# Operation Manual

Product Holding Bin  
DHB Sonic Series

## Product Identification

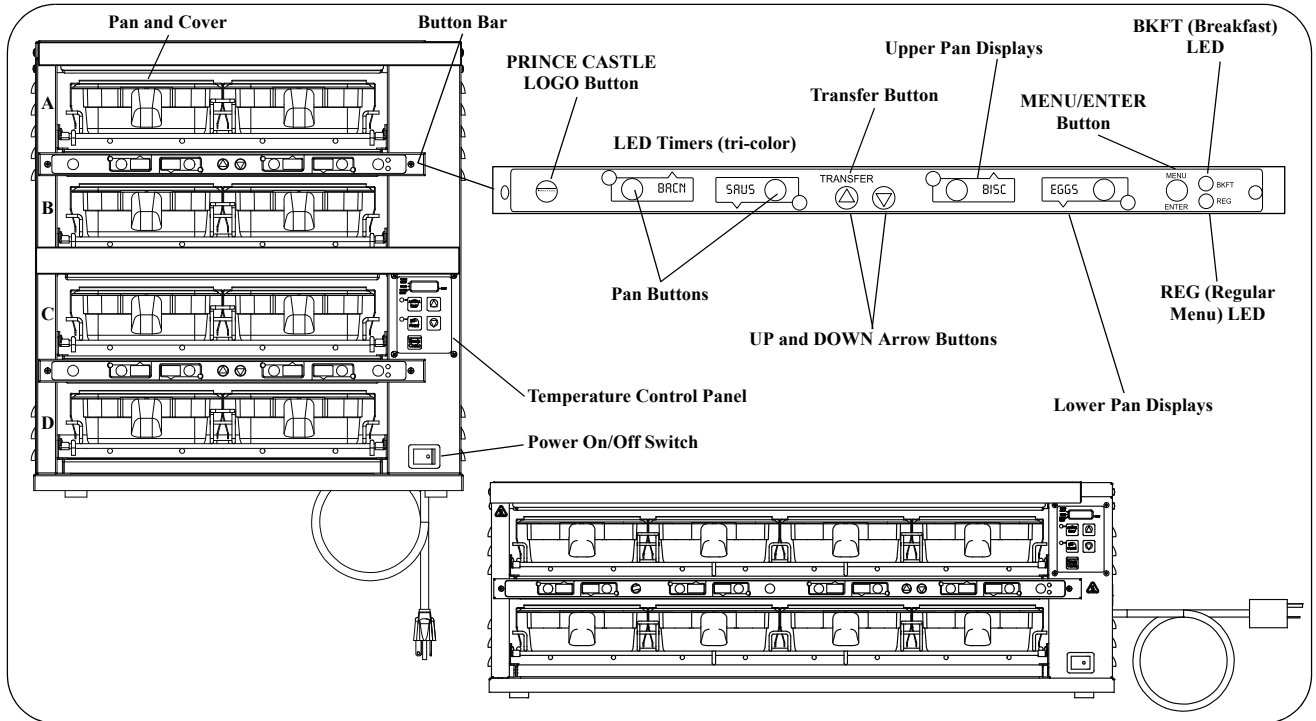

### LIMITED WARRANTY

This product is warranted to be free from defects in material and/or workmanship for a period of one (1) year from date of original installation (with the exception of racks, pans, and covers). Any component which proves to be faulty in material and/or workmanship will be replaced or repaired (at the option of Prince Castle, LLC) without cost to the customer for parts or labor. This warranty covers on location service (i.e. trip charges and/or mileage). Travel mileage is limited to 100 miles (200 kilometers -International) round trip (one trip warranty) from an authorized service agency or its sub-service agency.

This warranty is subject to the following exceptions/conditions:

- Use of any non-genuine Prince Castle parts voids this warranty.
- All labor shall be performed during regular work hours. Overtime premium will be charged to the buyer.
- Damage caused by carelessness, neglect, and/or abuse (e.g., dropping, tampering or altering parts, equipment damaged in shipment, by fire, flood or an act of God) is not covered under this warranty.

### TABLE OF CONTENTS

Product Identification .....	1
Specifications .....	2
Safety Information .....	2
Installation .....	2
Operation .....	3
Cleaning .....	4
Programming .....	5 – 14
Troubleshooting .....	11
Exploded View and Parts List .....	12
Wiring Diagrams .....	14 – 15



**PRINCE CASTLE LLC**  
WORLDWIDE 

205 Lies Road • Carol Stream, IL 60188 USA  
Telephone: 630-462-8800 • Toll Free: 1-800-PCASTLE  
Fax: 630-462-1460 • www.princecastle.com

## Specifications

Model	Voltage	Watts	Hertz
DHB2SS-33SNC	208-240VAC	2500	50/60
DHB2SS-33SNCFR	208-240VAC	2500	50/60
DHB4SS-20SNC	120VAC	1700	60
DHB4SS-20SNCGR	120VAC	1700	60
DHB2SS-20SNC	120VAC	900	60

## Safety Information



### WARNING

Indicates information important to the proper operation of the unit. Failure to observe may result in damage to the equipment and/or severe bodily injury or death.



### CAUTION

Indicates information important to the operation of the unit. Failure to observe may result in damage to the equipment.

## Installation

- A. Remove the unit from the carton and inspect for signs of damage. If there is damage to the unit:
- notify the carrier within 24 hours of delivery
  - save carton and packaging materials for inspection purposes
  - contact your local dealer, or if purchased directly, the Prince Castle Sales Department at 800-722-7853 or 1-630-462-8800 to arrange for a replacement unit.

*NOTE: When installing this unit, the ambient temperature at the mounting site should not exceed 100°F.*

- B. Place the bin on a counter and seal the base to the counter with food-approved sealant.
- C. Plug the power cord into the bin and connect the plug into the proper electrical outlet (15 amp, 120 VAC (4SS), 208-240 VAC (2SS)). All connections must be in accordance with local electrical codes and any other applicable codes.

*NOTE: The electrical receptacle should be a dedicated outlet. No other equipment should be operating on the line (refrigerators, fryers, etc.).*

- D. Install the racks, pans and pan covers into the cavities.
- E. Turn the power switch to ON. Allow 30 minutes for warm-up.

Prince Castle reserves the right to change specifications and product design without notice. Such revisions do not entitle the buyer to corresponding changes, improvements, additions or replacements for previously purchased equipment.

**Operation**

**1** Turn power On/Off switch to ON position.

Load pan covers (if used) onto pan racks and insert racks into the unit.

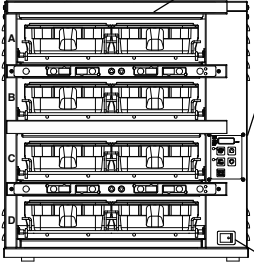

Allow **30 minutes** for heaters to reach operating temperature. The Temperature Display will show temperature as unit warms up to the operating temperature.

Power On/Off Switch

**2** Press all PAN buttons (if applicable).



The PAN DISPLAYS will show the assigned product name.

If no product is assigned, the display will be dim and show "----". Pressing the PAN button will not activate the timer if "----" is displayed. Pressing PAN button when product name is displayed will start timing cycle.

BKFT (Breakfast) or REG (Regular Menu) will be lit depending on pre-programmed menu.

**3** LED Timing Status



LED Timers

- RED (steady) = Timer idle, ready to start
- RED (flashing) = Discard product
- GREEN (steady) = Oldest product, use first
- GREEN (flashing) = Cook more product
- YELLOW (steady) = Newer product, use green first
- YELLOW (flashing) = Cook more product

**4** To begin timing cycle, load product and press the PAN button.

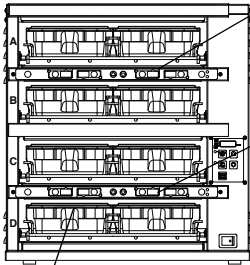

If no other pan is active for a product, the LED for the first pan loaded will turn GREEN.

The LED for the 2nd pan (3rd pan, etc.) loaded will turn YELLOW.

An LED timer can be stopped (cancelled) at any time by pressing and releasing the corresponding PAN button. Press button 3 times to cancel.

During cook-more alert, pressing the corresponding PAN button will silence the alert. Press button 1 time to silence alert.

If only one pan is active for a product, the LED will turn GREEN.

**Operation (continued)**

**5** When any of the timer LEDs flash, cook more product or remove and discard product as indicated.

**GREEN** Flashing = Cook more product

**YELLOW** Flashing = Cook more product

**RED** Flashing = Discard product

 **WARNING**  
**Hot Surfaces**

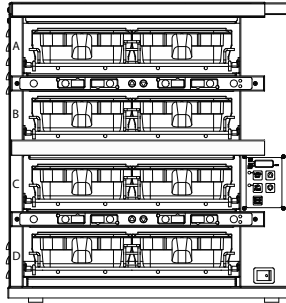

**6** Product, along with any remaining time, can be transferred from one cavity to another as follows:

- A. Press and release the TRANSFER button on the timer bar of the product to be moved. Displays for all pans available for transfer will be brightly lit. All others will be dimly lit.
- C. Press and release the TRANSFER button on the bar where the product will be moved. All available pan locations on the bar will be brightly lit.

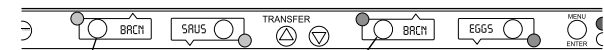

- B. Press and release the PAN button of the product to be moved.
- D. Press and release the PAN button for the new location. The new location will finish timing the product. When the transferred pan time expires, the location will revert back to the original menu settings.

*NOTE: If product transfer is not completed within a pre-programmed transfer time, the transfer will be cancelled. See your Manager.*

**7** To shut down the unit, turn the power On/Off switch to OFF.

*NOTE: To load preset times/menus:*

- A. Turn power switch to OFF.
- B. Press and hold both the UP and DOWN Arrow buttons.
- C. Turn power switch ON.
- D. When the four right-most displays show PRESET LOADED, release the buttons.

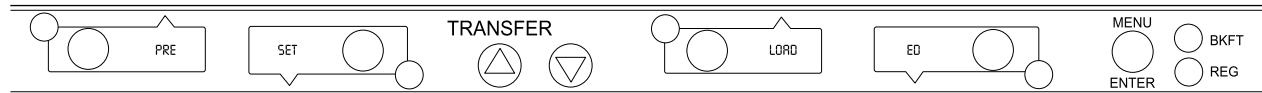

**Cleaning**

 **WARNING**

Before performing any maintenance, turn the power switch to the OFF position and unplug the power cord from the electrical receptacle.

 **CAUTION**

This unit is not watertight. Do not clean with a water jet/jet spray. Do not immerse the unit in water.

- 1. Turn the unit off and unplug the power cord from the electrical receptacle.
- 2. Remove the pan covers and pan racks. Wipe all parts and unit with a damp cloth. DO NOT use a green Scotch Bright pad cleaner, ice or water.

## Setting the Temperature

- 1** Each shelf has an upper and lower heater.  
See table for factory pre-set temperatures.  
Each upper heater has a programmable range of 150° – 275°F.  
Each lower heater has a programmable range of 150° – 225°F.  
Use the control below and the following steps to set the setpoint temperatures for each heater.

**CAUTION**  
DISPLAYED TEMPERATURES  
ARE HEATER TEMPERATURES  
AND DO NOT INDICATE ACTUAL  
FOOD TEMPERATURES.

**UPPER HEATER LED**  
This LED will be lit to indicate upper shelf is selected.

**PROG LED**  
This LED will be lit to indicate unit is in Program Mode.

**LOWER HEATER LED**  
This LED will be lit to indicate lower shelf is selected.

**ACTUAL TEMP BUTTON and LED**  
Press to display actual temperature for the selected heater. LED will be lit when actual temperature is displayed.

**SETPOINT BUTTON and LED**  
Press to display setpoint temperature of a selected heater. LED will be lit when setpoint temperature is displayed.

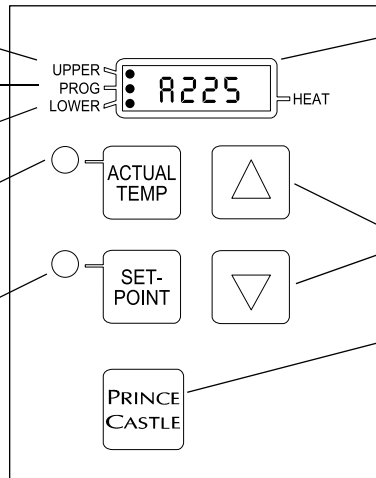

**TEMPERATURE DISPLAY**  
*NOTE: The unit is preset to display temperature in Fahrenheit. To display in Celsius, press and hold the DOWN Arrow button immediately after turning on the power switch. To switch back to Fahrenheit, press and hold the UP Arrow button after turning on the power switch.*

**UP/DOWN ARROW BUTTONS**  
Used with other buttons to scroll through heater and temperature selections.

**PRINCE CASTLE LOGO BUTTON**  
Press to enter temperature selections.

2-SHELF	4-SHELF
225°F	265°F
195°F	185°F
225°F	250°F
195°F	185°F

*NOTE: To reset all times and temperatures to the factory settings, turn the unit off, then press and hold the UP and DOWN Arrow buttons simultaneously while turning the unit back on. A "P" will appear in the display and all times and temperatures will be reset to original factory settings.*

- 2** Press the UP or DOWN Arrow button until the desired shelf (U, L for 2 shelf unit, A, b, C or d for 4 shelf units) LED and upper or lower heater is selected.

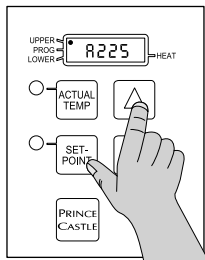

- 3** Press and hold the SETPOINT button and the PRINCE CASTLE LOGO button for 5 seconds. The Program LED will light.

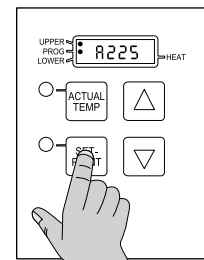

- 4** Press the UP or DOWN Arrow button until the desired setpoint temperature is displayed.

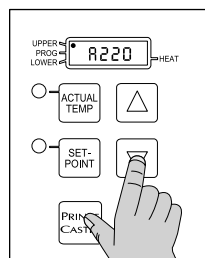

- 5** Press the PRINCE CASTLE LOGO button to save the new setpoint value. Repeat Steps 2 – 5 to change the setpoint for any other heater.

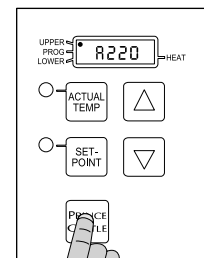

**Calibrating Heaters**

**1** Use the following steps to calibrate the individual heaters.

*NOTE: Allow sufficient amount of time for temperatures to stabilize before starting calibration.*

Press the UP or DOWN Arrow button until the desired heater LED and shelf is selected.

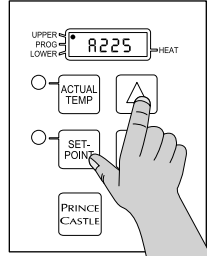

**2** Take a temperature reading within the shelf near the center of the heater surface.

Use a stand-alone temperature meter (not supplied).



**WARNING**  
Hot surfaces. Use caution when taking temperature readings within the shelf.

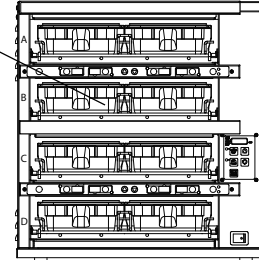

**3** A. Press and hold the PRINCE CASTLE LOGO and ACTUAL TEMP buttons for 5 seconds. The colon (:) LED indicator will light. The temp displayed is the actual heater temperature sensed by the controller.

B. To clear any offset readings, press the SETPOINT button.

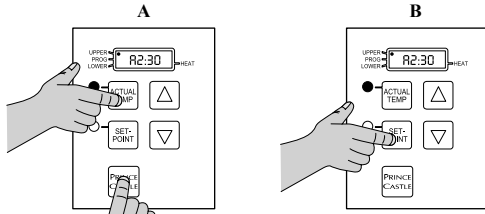

**4** A. Press the UP or DOWN Arrow button until the temperature displayed matches the reading obtained in Step 2.

B. Press the PRINCE CASTLE LOGO button to save the temperature value and exit the Calibration Mode.

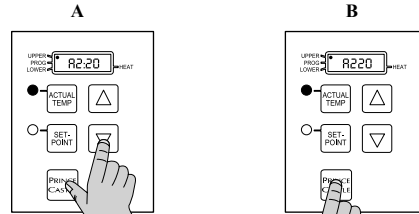

**Selecting Breakfast and Regular Menus**

**1** There are six menus available:  
BKFT LED ON = Menu1 or Menu6

REG LED ON = Regular2, Regular3, Regular4, or Regular5

Press and hold the MENU/ENTER button, then use the UP or DOWN Arrow button to scroll through the 6 menus.

When scrolling, menu numbers appear in this display.

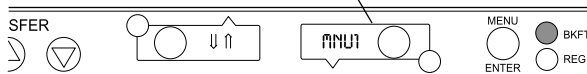

**2** When the desired menu is displayed, release the MENU/ENTER button. The food products for the menu will be displayed in the upper and lower PAN displays.

When timers for a different menu are still active, those BKFT or REG LEDs will flash until they are all cancelled.

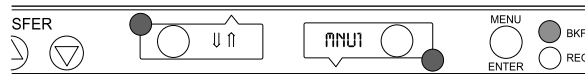

## Programming the Menus

- 1** Press and hold the PRINCE CASTLE LOGO button (on the button bar) until all the displays show PROG.

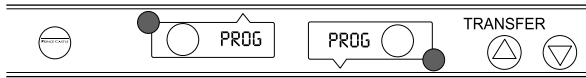

- 2** Press and hold the MENU/ENTER button. The display next to the MENU/ENTER button will show the menu choices. Use the UP or DOWN Arrow button to scroll through the 6 menus. Release the MENU/ENTER button when the desired menu is displayed.

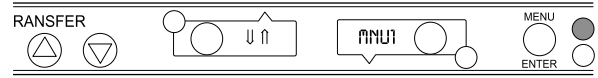

When the MENU/ENTER button is released, all displays will again show PROG.



- 3** A. Press the PAN button next to the display to be changed. The LED will turn YELLOW and the display will change from PROG to the assigned product choice.

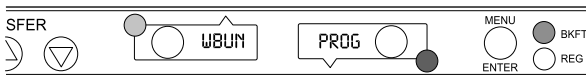

- B. Press the UP or DOWN Arrow button to scroll to the desired product choice.  
C. Press the MENU/ENTER button to save the selection. All displays will show PROG.

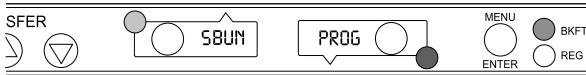

- 4** A. Repeat Steps 2 and 3 as required.  
B. Press the PRINCE CASTLE LOGO button to exit the Program Mode and return to the Run Mode.

*NOTE: Up to six items (one for each menu) may be programmed for each PAN button. A pan may be set as "not used" by assigning "----" as its product.*



## Changing the Hold and Cook-More Times

- 1** A. The SET PRODUCT TIME menu is used to change the Hold and Cook-More times.  
B. Press and hold the PRINCE CASTLE LOGO button, then immediately press and hold the MENU/ENTER button until the display shows one of the programming menus.  
C. Use the UP or DOWN Arrow button to scroll to the PROD TIME ↑ ↓ ENTR menu. (*NOTE: Units with 6 or 8 Pan displays will show SET PRODUCT TIME ↑ ↓ ENTR.*)

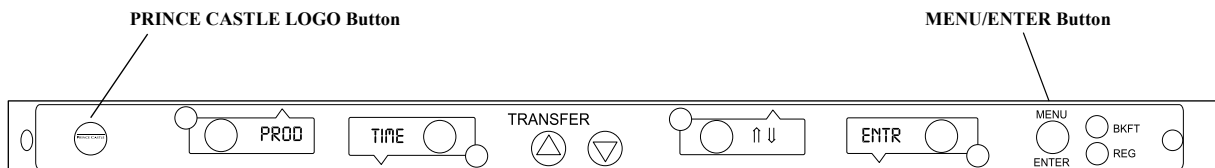

## Changing the Hold and Cook-More Times (continued)

- 2** A. Press and release the MENU/ENTER button to enter the Set Product Time menu. The display will show, for example, EGGS TIME ↑ ENTR.
- B. Use the UP or DOWN Arrow button to scroll through the list of products. When the desired product is displayed, press the MENU/ENTER button to select it.



*NOTE: Holding the UP or DOWN Arrow button for longer than 2 seconds will cause the product list to automatically scroll up or down.*

- 3** A. The display now shows the current Hold time.



- B. Use the UP or DOWN Arrow button to scroll to the desired Hold time. When the desired Hold time is displayed, press the MENU/ENTER button to save the desired Hold time.



*NOTE: Hold time cannot be reduced to less than the Cook-More time plus one minute.*

- 4** A. The display will now show current Cook-More time. Use the UP or DOWN Arrow button to scroll to the desired Cook-More time.



- B. When the desired Cook-More time is displayed, press the MENU/ENTER button to save it.



*NOTE: Cook-More time cannot be increased to more than the Hold time minus one minute.*

- 5** A. The display will show PROD TIME ↑ ENTR. Repeat Steps 2 – 4 for any other product.

- B. Press and release the PRINCE CASTLE LOGO button at any time to exit the Program Mode and return to the Run Mode.

*NOTE: If the MENU/ENTER button has not been pressed to save any changes, the program will revert to the original values.*



## Setting the Alternating Display Interval

- A. The Alternating Display Interval allows the timer bar displays to alternate between the product name and remaining Hold time. The default setting is 5 seconds.
- B. Press and hold the PRINCE CASTLE LOGO button, then immediately press and hold the MENU/ENTER button until the display shows one of the programming menus.
- C. Use the UP or DOWN Arrow button to scroll to the DISP ALT TIME menu. Press MENU/ENTER button.
- D. Use the UP and DOWN Arrow buttons to adjust the interval setting from 0 to 15 seconds. Press MENU/ENTER to save the change. Setting to "0" seconds will set the display to only show the product name. No alternating time.
- E. Press and hold the PRINCE CASTLE LOGO button at any time to exit the Program Mode.

PRINCE CASTLE LOGO Button

MENU/ENTER Button





## Changing Product Names

- 1** A. The EDIT PRODUCT NAME menu is used to change a default product name to one of your own choosing.
- B. Press and hold the PRINCE CASTLE LOGO button, then immediately press and hold the MENU/ENTER button until the display shows one of the programming menus.
- C. Use the UP or DOWN Arrow button to scroll to the PROD NAME ↑ ↓ ENTR menu.

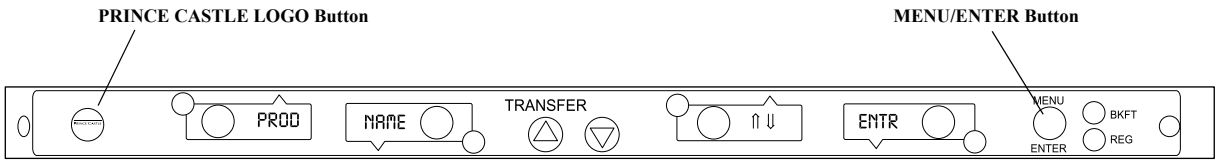

- 2** A. Press and release the MENU/ENTER button to enter the Edit Product Name menu.  
The display will read PROD XXXX ↑ ↓ ENTR.
- B. Use the UP or DOWN Arrow button to scroll through the list of products.
- C. When the desired product is displayed, press the MENU/ENTER button to select it. The first letter will start blinking.



- 3** A. To change the blinking letter, use the UP or DOWN Arrow button to scroll to the desired letter/number/symbol.
- B. When the desired selection is displayed, press the PAN button (to the left or right of the selected display) to move to the next digit.
- C. Repeat for all digits.



*NOTE: Holding the UP or DOWN Arrow button for longer than 2 seconds will cause the selected digit to automatically scroll up or down.*

- 4** When all four digits have been changed, press the MENU/ENTER button to save the new name.



- 5** A. The display will show PROD NAME ↑ ↓ ENTR. Repeat Steps 2 – 4 for any other product.
- B. Press and release the PRINCE CASTLE LOGO button at any time to exit the Program Mode and return to the Run Mode.

*NOTE: If the MENU/ENTER button has not been pressed to save any changes, the program will revert to the original names.*



### Set Volume Level

- 1** A. The default setting for the volume level is 3.  
B. Press and hold the PRINCE CASTLE LOGO button, then immediately press and hold the MENU/ENTER button until the display shows one of the programming menus.  
C. Use the UP or DOWN Arrow button to scroll to the Set Vol 0 ↑ ↓ ENTR menu.

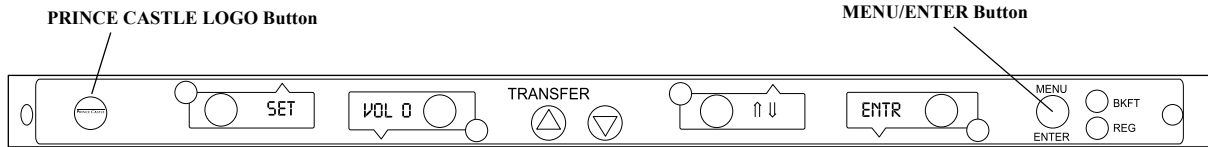

- 2** A. Press and release the MENU/ENTER button to enter the Set Volume menu.  
B. The display shows SET VOL 0 ↑ ↓ ENTR. This shows that the volume is currently turned off.  
The volume may be set for Vol 0 (off) or for volume levels Vol 1 through Vol 3.

- 3** A. To change the volume level, use the UP or DOWN Arrow button to scroll to the desired level. When the desired selection is displayed, press the MENU/ENTER button.  
B. Press and release the PRINCE CASTLE LOGO button at any time to exit the Program Mode and return to the Run Mode.  
*NOTE: If the MENU/ENTER button has not been pressed to save any changes, the program will revert to the original time.*

### Set Bar Position 4-Shelf Unit

- 1** To check the timer position on the main bar, press and hold the PRINCE CASTLE LOGO button and the DOWN Arrow button. The current timer bar position will be displayed in the far right timer display as POS X.  
*NOTE: X = the setting.*  
To change the timer bar position, proceed to Step 2.  
To check the timer position on the aux bar press and hold the logo only.

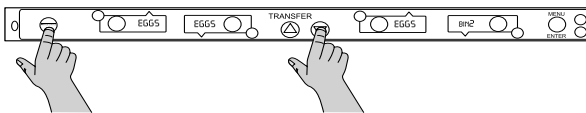

- 2** To change the main timer bar position, press and hold the PRINCE CASTLE LOGO button and the DOWN Arrow button for approximately 6 seconds or until the display shows POSN ↑ ↓ ENTR POS X.  
The address number will blink on/off.  
*NOTE: X = current bar position setting. SET will not show on the 4 channel bar.*

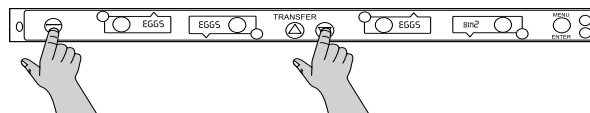

- 3** Use the UP or DOWN Arrow button to scroll to the desired position. The right most display shows the position letter to be selected. Press the MENU/ENTER button to store the new position and return to normal Operating Mode.  
*NOTE: The position choices for 2 cavity bins are A and B. The position choices for 4 cavity bins are A through F.*  
*If the bin has a corresponding aux timer bar on the back, the aux bar will automatically update itself to match the position selection of its main bar.*  
*NOTE: To cancel at any time with saving changes, press the LOGO button.*

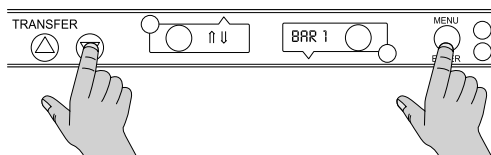

- 4** To check the current position setting on the main timer bar without making a change, press and hold the LOGO and the DOWN buttons simultaneously. On the aux timer bar, press and hold the LOGO button only.  
One of the displays will show POS X to indicate the current position setting, where X is the setting.

## Timer Bar Positions on Bins

### DHB4SS-20SNC/DHB4SS-20SNCGR

Four cavity bin with two 4-channel timer bars:

Timer Bar Position A, Address 1

Timer Bar Position B, Address 2

## Bar Address

To check the bar address on the main timer bar, press and hold the LOGO button and the DOWN Arrow simultaneously. On the aux bar press and hold the LOGO only button. The bar address is shown as BARY as on other bars where y is the address.

The Timer Bar address is automatically set when the Bar Position is selected as follows:

Position	Address Default
A	1
B	2

The address can be changed at power on as on other bars, but loading presets will change the address back to the default in the list above. Loading presets will not change the selected position.

## Troubleshooting

PROBLEM	PROBABLE CAUSE	SOLUTION
Display flashes Opn and rEL.	Open relay. Circuit inoperable.	Consult an authorized Service Technician.
Display flashes SHr and rEL.	Shorted relay. Circuit inoperable. Open heater. Unplugged ribbon cable between power and main circuit boards.	Consult an authorized Service Technician.
Display flashes Opn and rEL.	Temperature is below 75°F. Heater inoperable. Probe inoperable. Relay inoperable.	Consult an authorized Service Technician.
Display shows HHH for an extended period of time and heater surface temperature is hot.	Temperature is above 300°F (abnormal operation).	Consult an authorized Service Technician.
Display shows HHH for an extended period of time and heater surface temperature is cool.	Probe is inoperable.	

**Exploded View and Parts List**

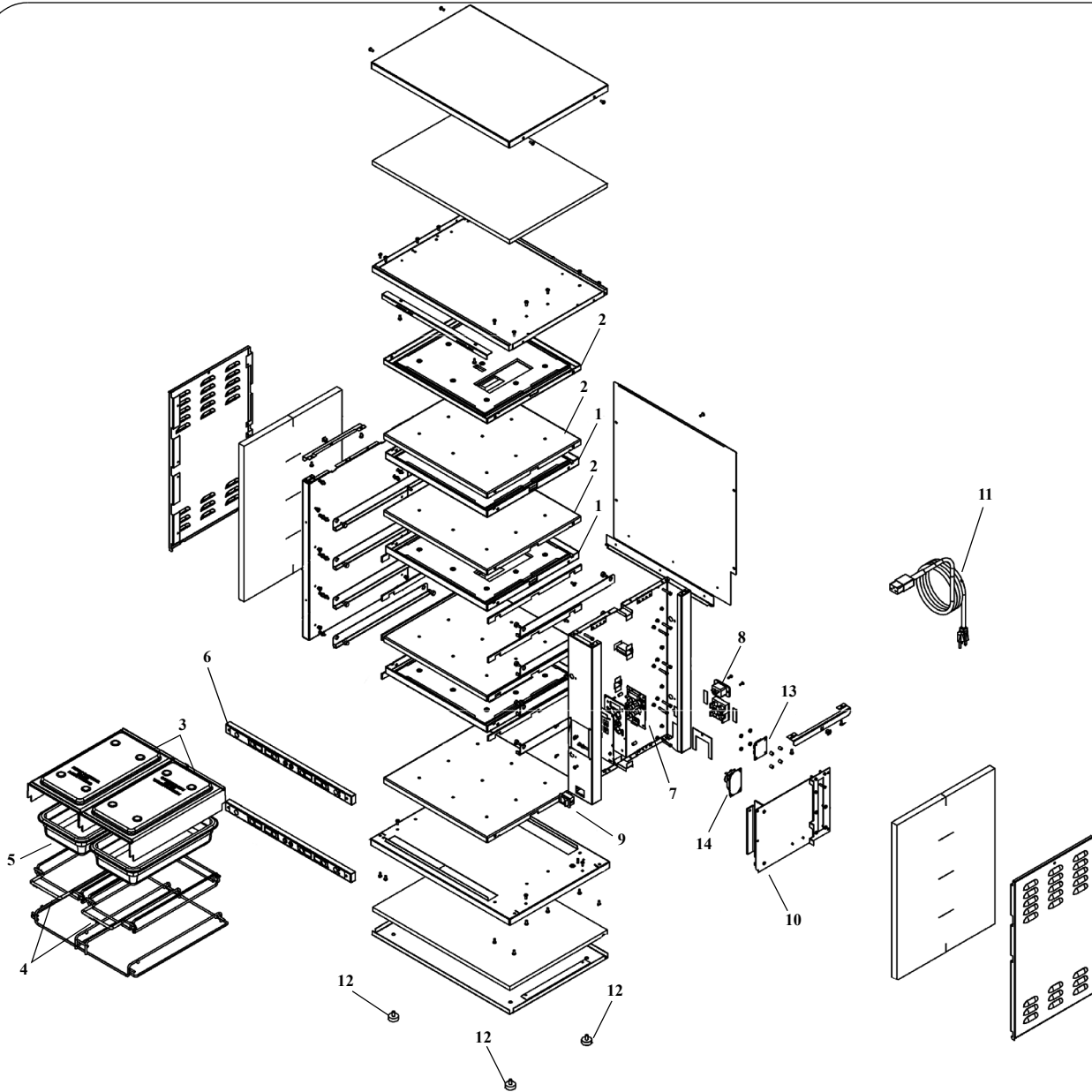

Ref.	Part No.	Description
1	542-154	Upper Heater Assy Kit
2	542-153S	Lower Heater Assy Kit
3	541-723E4S	Lid
4	542-169S	Rack Kit
5	541-1095S	Pan
6	541-1189S	Main Timer Bar Kit
7	541-719S	Display PCB

Ref.	Part No.	Description
8	541-1183S	Main PCB (541-1285S DHB2SS-20SNC)
9	78-233S	Lighted Rocker Switch
10	88-609S	Power Inlet Connector Kit (541-1285S DHB2SS-20SNC)
11	72-200-15S	Power Cord Kit
12	197-232S	Rubber Foot (Pkg of 4)
13	88-709-2-11S	Speaker Kit
14	741-650S	Audio PCB Interface Assy

**Exploded View and Parts List (continued)**

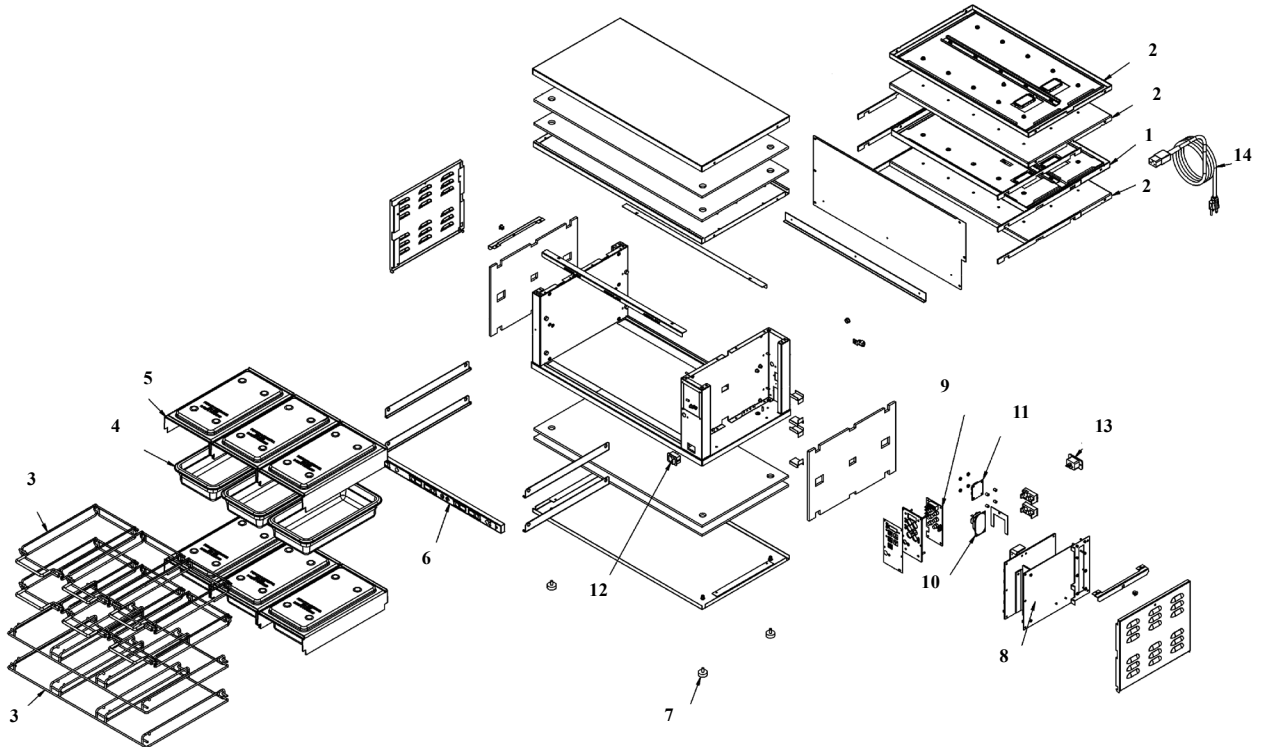

Ref.	Part No.	Description	Ref.	Part No.	Description
1	541-376S	Upper Heater Kit	8	541-1185S	Main PCB Kit
2	541-375S	Lower Heater Kit	9	541-719S	Display PCB Kit
3	541-636S	Rack Kit	10	88-709-2-11S	Speaker Kit
4	541-1095	Pan With Handle, Amber	11	541-959S	PCB Audio Interface Kit
5	541-723E4S	Cover (Pkg of 4)	12	78-184S	Power Switch
6	541-1187S	Timer Bar Kit	13	86-609S	Power Inlet Connector
7	197-232S	Mounting Foot (Pkg of 4)	14	72-436S	Power Cord



Wiring Diagrams (continued)

DHB2SS-33SNC/DHB2SS-20SNC

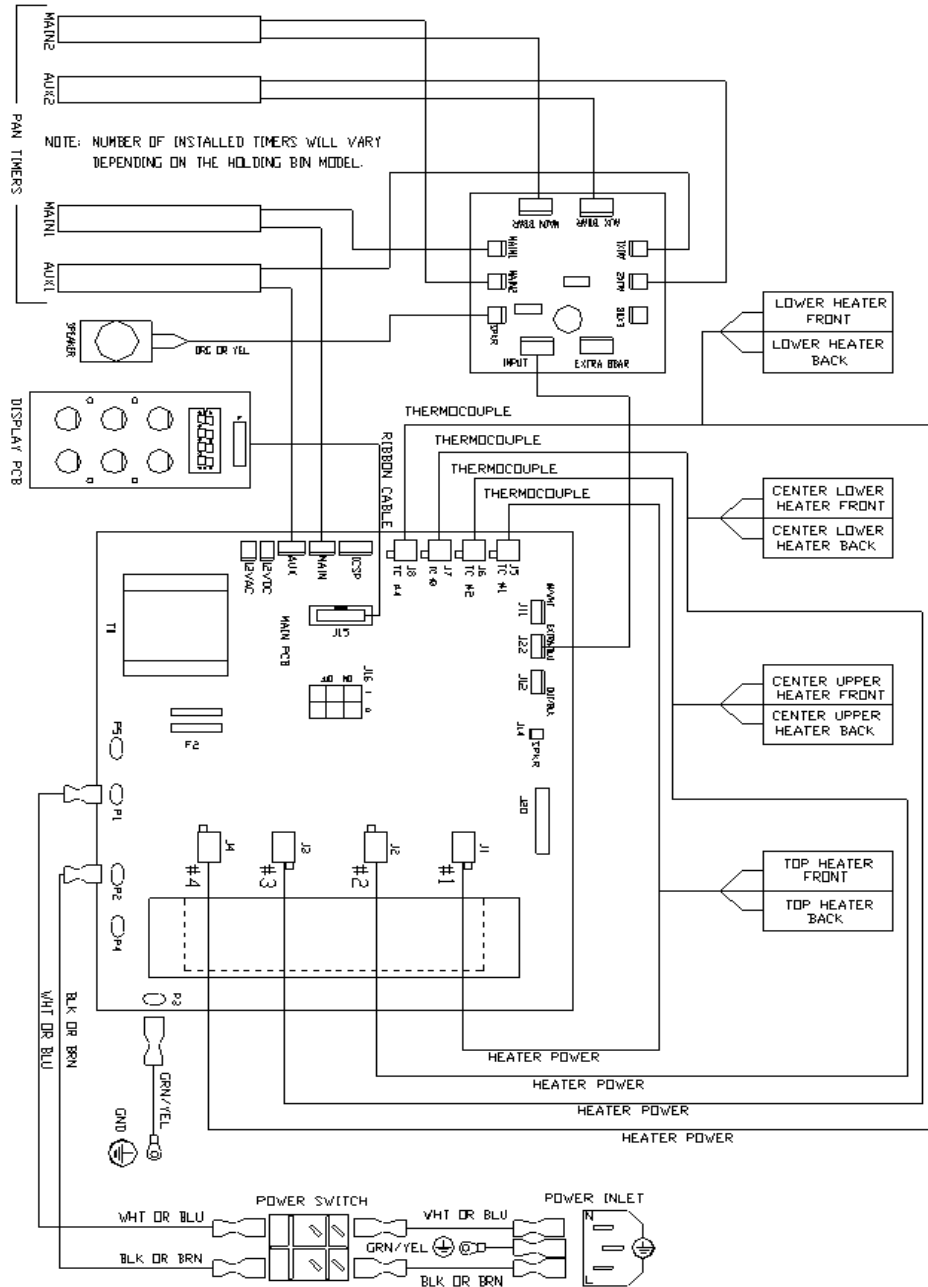

**Product Holding Bin**  
**DHB Sonic Series**

---



**Wiring Diagrams (continued)**

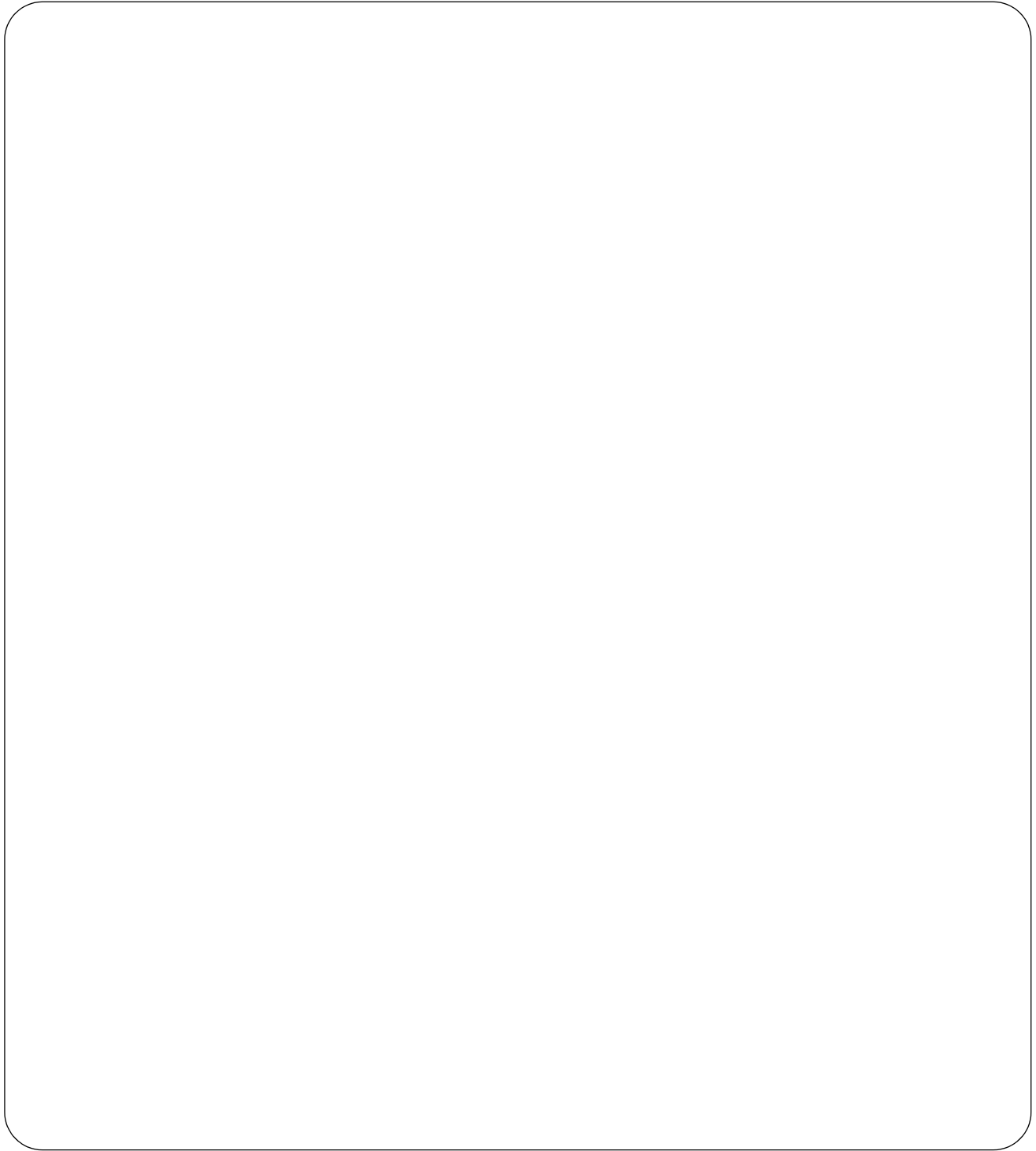

**Product Holding Bin**  
**DHB Sonic Series**

---