

**HEATED LANDING SHELF
PRINCE CASTLE MODEL NO. STB-11 & STB-22 SERIES**



This equipment chapter is to be placed in the Miscellaneous Section of your *Equipment Manual*

**MANUFACTURED BY
PRINCE CASTLE INC.
355 E KEHOE BLVD
CAROL STREAM, IL 60188 USA
PHONE 1-630-462-8800
TOLL FREE NUMBER
1-800-323-2930
FAX: 1(630)462-1460**



MODEL NO. STB-11



MODEL NO. STB-22

TABLE OF CONTENTS

WARRANTY	Page 1
INTRODUCTION	Page 2
PARTS IDENTIFICATION	Page 2
EXPLODED VIEW	Page 3
EQUIPMENT SET-UP AND CLOSE PROCEDURES	Page 4
ORDERING PARTS AND SERVICE	Page 4
TROUBLESHOOTING	Page 5
TRANSLATIONS (FRENCH, GERMAN, SPANISH, ITALIAN)	Page 6-13
WIRING DIAGRAMS	Page 14-16

LIMITED WARRANTY

This product is warranted to be free from defects in material and/or workmanship for a period of (2) years from date of original installation not to exceed 30 months from date of shipment from our factory. Printed circuit boards and platen are warranted for a period of (3) years from date of original installation not to exceed 42 months from date of shipment from our factory. Any part or component which proves to be faulty in material and/or workmanship within the warranty period will be replaced or repaired without cost to the customer for parts or labor. (At the option of Prince Castle, Inc.)

This warranty is subject to the following exceptions/conditions:

- This warranty covers on location service (i.e., trip charges and or mileage). Travel mileage is limited to 100 miles (200 kilometers) round trip (one trip per warranty) from an authorized Service Agency or it's sub-service agency. All labor must be performed during regular working hours. Over-time premium will not be covered.
- Any use of non-genuine Prince Castle replacement spare parts voids this warranty.
- Damage caused by carelessness, neglect, and/or abuse (e.g., using wrong current, dropping , tampering with or altering electrical components, or improper cleaning) is not covered.
- Equipment damaged in shipment, by fire, flood or an act of God.

This manual is for the exclusive use of licensees and employees of McDonald's Systems, Inc.

INTRODUCTION

The Heated Landing Shelves are designed for special venues where space is at a premium. The STB-11 holds up to 16 sandwiches on one shelf. The STB-22 holds up to 32 sandwiches on two shelves. Adjustable lane dividers can be realigned for existing or new products. The Shelves have adjustable heaters to maintain correct temperatures at various locations. Plastic Trays are used for Regular Hamburgers and Regular Cheeseburgers only.

PARTS IDENTIFICATION LIST

ITEM	PART NO.	DESCRIPTION
2	536-23	Lane Divider
3	536-17	Wire Rack
4	65-037S	Solid State Relay
5	76-640	Slotted Binder Head Screw
6	73-015	Hex Nut
7	536-33	Potentiometer Door
8	536-9S	P.C. Board Assy
9	411-133s	Potentiometer Assy.
10	89-156	Spacer
11	213-257S	Pilot Light
12	78-166S	Rocker Switch
13	72-207S 72-200-11 72-234S	Power Cord (STB-22) Power Cord (STB-11) Power Cord (CE)
14	536-31	Control Panel Assy.
15 ●	536-45S	Heater
●	NOT SHOWN	

EQUIPMENT SET-UP AND CLOSE PROCEDURES

Set - up

1. Place **Heated Landing Shelf** on counter.
2. Insert the **6 FT Power Cord W/ NEMA 15-P Plug** into a **120 Volt, grounded outlet**. **NOTE:** International units come with a **6 FT Power Cord with no Plug** attached. International units should be attached to a **220 Volt, 50/60 Hertz, Single Phase Outlet**.

NOTE: This should be a dedicated outlet. No other equipment should be operating on this line (i.e. fryers, refrigerators, cash registers, etc.)

3. Turn **Power Switch (A) "ON"**. The **Amber Power Light (B)** will turn on. Allow **20 minutes** for warm-up.

FRONT CONTROL PANEL

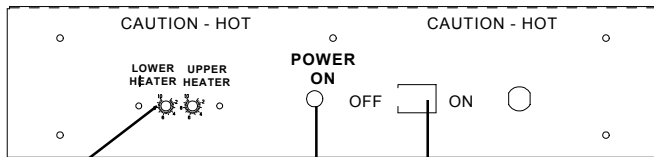

NOTE: STB-11 has
(1) Adjustment Potentiometer

4. Snap in Wire Racks with lip to counter.
5. Place all other products on the wire rack.
6. Refer to your operation and procedure manual for correct holding times.

Close Procedures

Caution: Before unplugging power cord make sure **Power Switch** is in "OFF" position.

1. Unplug Heated Landing Shelf From outlet.
2. Allow unit to cool down.(About 15 Minutes)
3. Wipe down with a damp cloth.

CAUTION: When cleaning do not pour water on the heaters. This may cause an electrical hazard and damage to the sensitive solid state circuitry.

ORDERING / SERVICE INFORMATION

PARTS

1. WHERE AND HOW TO ORDER REPLACEMENT PARTS.

To order replacement parts. Look on the back of the price list for your local Prince Castle Service Center, or call Prince Castle at 1-800-323-2930 and we will help you.

Then call your local Prince Castle Service Center. Fill in name and number here.

INTERNATIONAL

Contact your kitchen Equipment Supplier or designated repair facility for parts and service.

2. PARTS RETURNS

Should the need ever arise to return parts to your Center for credit, it is necessary that you:

- Obtain authorization from your Service Center for such return;
- All warranty situations should be handled by your Service Center.

3. PRICES

A. All prices are F.O.B. Prince Castle Service Center or F.O.B. factory, Carol Stream Illinois.

B. All prices are subject to change without notice. These prices are exclusive of all sales taxes or any special taxes which may be levied by federal, state, or city governments.

Parts price lists are sent to the U.S.A. restaurants once a year, which indicates the prices available from your local Center.

4. TERMS

Net 30 days.

INSPECT CARTON

Remove product from carton... if damaged:

- Notify Carrier
- Save carton and packing material
- Contact Prince Castle Customer Sales for replacement.

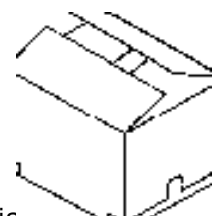

EXPLODED VIEW

NOTE: The one and two shelf Transfer Bins have the same internal parts.

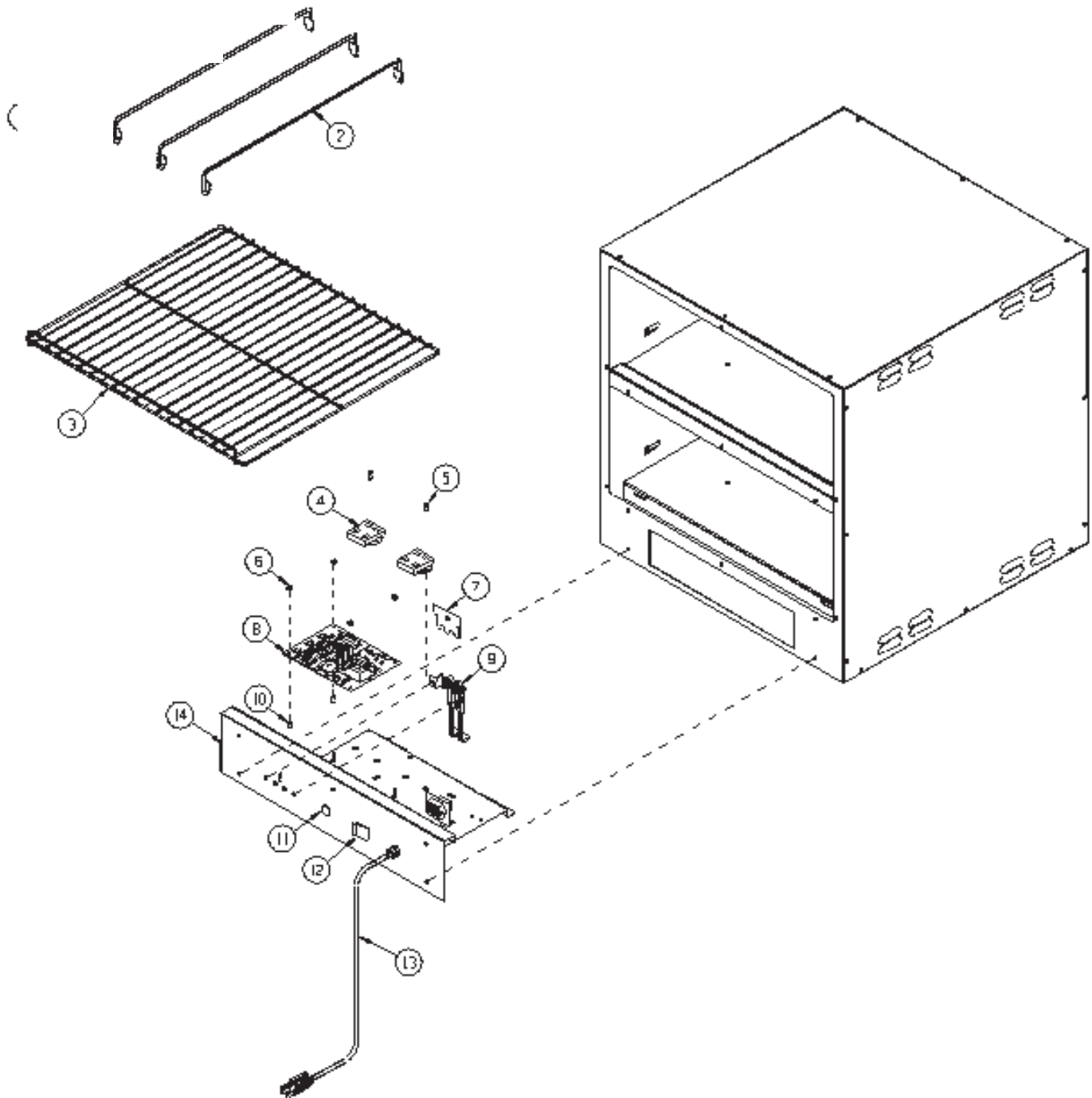

TROUBLESHOOTING GUIDE

In the event that the shelf(s) do not heat, first determine that power has not been interrupted to the Heated Landing Shelf. This can easily be confirmed by the "POWER ON" light on the control panel. Assuming that the unit has power, determine whether or not the temperature adjustments are at their proper settings.

To fully diagnose the Heated Landing Shelf further, it will be necessary to access the control compartment. To accomplish this, first unplug the power cord, remove the four (4) corner screws and the top center screw on the cover, and slide the drawer out. The cover must be lifted over the lip of the chassis before the drawer can be pulled out. Replug the power cord. Turn the Heated Landing Shelf on.

CAUTION: HAZARDOUS VOLTAGE PRESENT WITHIN CONTROL COMPARTMENT. Do not touch any connector or Printed Circuit Board while the Heated Landing Shelf is plugged in.

Note the four red LEDs on the printed circuit board under the letters "UPR" (meaning upper) and "LWR" (meaning lower). The upper two LEDs indicate that the circuitry is telling the Heater Control Relays to turn on ("RLY SIG"). The lower LEDs indicate that the Heater Control Relays are on ("RLY ON").

PROBLEM	CAUSE	SOLUTION
"RLY SIG" LED does not turn on, even when temperature setting is increased.	<ol style="list-style-type: none"> 1. Temperature Adjust disconnected from circuit board. 2. Inoperable Circuit Board. 3. Inoperable Temperature Adjust Control. 4. Temperature Sensor Wire Disconnected at Circuit Board. 5. Temperature Sensor Wire Disconnected within cabinet. 	<ol style="list-style-type: none"> 1. Reconnect Temperature Adjust to Circuit Board. 2. Replace Circuit Board. 3. Replace Temperature Adjust Control. 4. Check Sensor Wire Connection on Circuit Board. 5. Check Sensor Wire Connection inside Cabinet.
"RLY SIG" LED is on, but "RLY ON" LED is off.	<ol style="list-style-type: none"> 1. "RLY CONTROL" connector loose. 2. "RLY DIAGN" connector loose. 3. Loose connection on Heater Control Relay. 4. Inoperable Heater Control Relay. 	<ol style="list-style-type: none"> 1. Check Connector for tightness. 2. Check Connector for tightness. 3. Check Connection To Relay. 4. Replace Heater Control Relay.
"RLY SIG" and "RLY ON" LEDs are both on but no heat.	<ol style="list-style-type: none"> 1. Loose connection in heater harness within cabinet. 2. Inoperable Heater. 	<ol style="list-style-type: none"> 1. Check all Heater Harness Connections. 2. Replace Heater.
Too much heat. "RLY SIG" and "RLY ON" LEDs stay on even when temperature setting is decreased.	<ol style="list-style-type: none"> 1. Inoperable Temperature Adjust Control. 2. Inoperable Circuit Board. 3. Inoperable Heater. 	<ol style="list-style-type: none"> 1. Replace Temperature Adjust Control. 2. Replace Circuit Board. 3. Replace Heater.
Too much heat. "RLY SIG" LED is off but "RLY ON" led is on.	<ol style="list-style-type: none"> 1. Inoperable Heater Control Relay. 	<ol style="list-style-type: none"> 1. Replace Heater Control Relay.
Heated Landing Shelf is heating okay, but no "POWER ON" light.	<ol style="list-style-type: none"> 1. "PWR LIGHT" connector loose. 2. Inoperable "POWER ON" light. 	<ol style="list-style-type: none"> 1. Check "PWR LIGHT" Connection. 2. Replace "POWER ON" light.
No heat. "POWER ON" light, "RLY SIG", and "RLY ON" LEDs are off. Heated Landing Shelf is plugged in and turned on.	<ol style="list-style-type: none"> 1. Tripped circuit breaker in store. 2. "PWR SWITCH" connector loose. 3. Connections at Power Switch loose. 4. Inoperable Circuit Board. 5. Inoperable Power Switch. 6. Inoperable Power Cord. 	<ol style="list-style-type: none"> 1. Check Circuit Breaker in store. 2. Check "PWR SWITCH" Connection. 3. Check Power Switch Connection. 4. Replace Circuit Board. 5. Replace Power Switch. 6. Replace Power Cord.



CARD NO.

72

HEATED LANDING SHELF

Planned Maintenance System Maintenance Requirement Card (MRC)

Temperature & Calibration of STB-22& STB-11

The Heated Landing Shelf leaves the factory with the plate temperature set at 225-230 ° F. (107-110 ° C.) Readings with the Surface Probe should be taken at the surface of the heaters 2" to the right of the center screw on top and bottom (SEE FIGURE BELOW). **NOTE: Because the location of the Heated Landing Shelf may vary from restaurant to restaurant there may be a need to adjust the temperature setting due to climate control conditions in that location.**

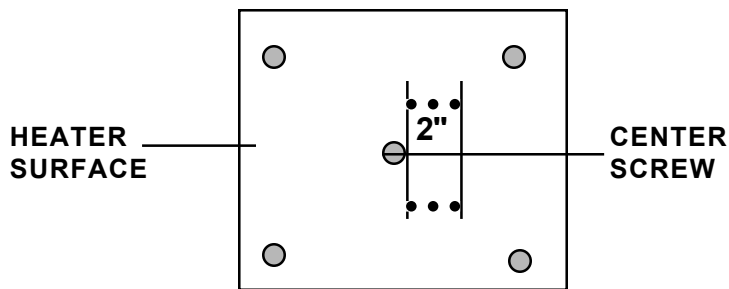

The following "Water Test" is intended for use only when the integrity of the Heated Landing Shelf is questioned by regulatory agencies, ie; health department, etc.

MATERIALS REQUIRED:

- 1ea. 8oz. paper (CAUTION: Do not use "Waxed Paper Cup) or styrofoam coffee cup with lid (lid may be plastic)
- 1ea. "K" type thermometer and probe, or a conventional bulb type thermometer capable of reading in the 100-200 ° F. range (35-100 ° C.)

PRODUCT SIMULATION:

Place 4 tablespoons (1/4 cup) of water in the paper cup. Use hot water, or microwave until the temperature of the water measures 155-160 ° F. (68 - 71° C.) Immediately place the lid on the cup and place the cup anywhere on the wire rack in the Transfer Bin.

WARNING: DO NOT place any object under the cup (paper, plastic, foil, cardboard, etc...) to help "balance the cup" on the rack.

After 10 minutes, place the cup on the counter, immediately insert thermometer end (or needle probe) thru a small (1/4" max.) hole in the lid, and record the temperature of the water. If the temperature is between 140-150 ° F (60 - 65° C.) the unit is operating as intended. If the temperature of the bin is too high or too low it can be adjusted by turning the adjustment potentiometer located behind the access door on the front of the transfer bin.

NOTE: To raise access door loosen the screw in between the two heater pots, (NOTE: on STB-11 screw above single Pot) then raise up exposing the adjustment potentiometer(s) .

Turning the pot clockwise will adjust the temperature up, turning it counter clockwise will adjust it down. Each small mark will cause about a 5 Degree adjustment in temperature.

WIRING DIAGRAM

WIRING DIAGRAM (STB-11)

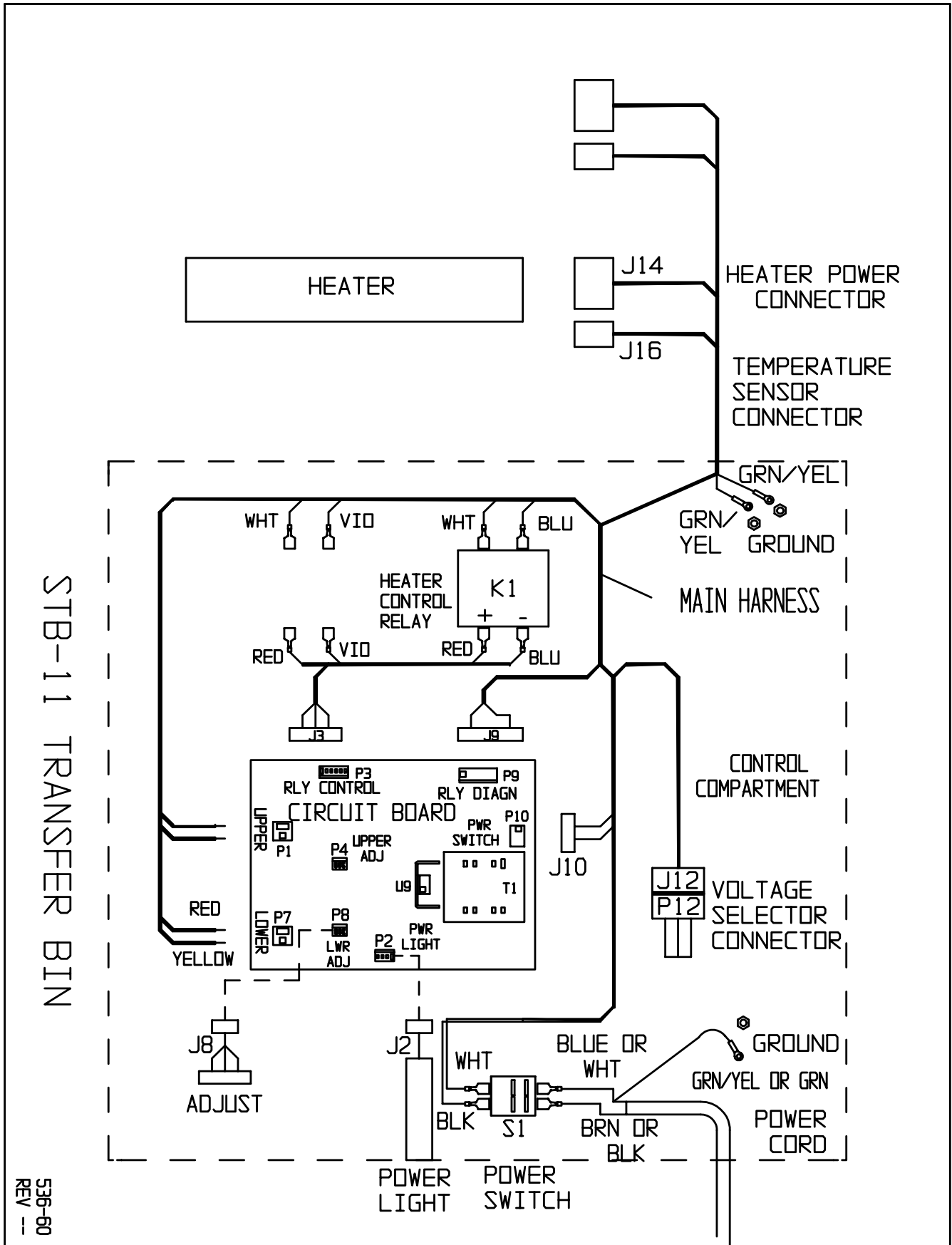

STB-11 TRANSFER BIN

536-60
REV --

WIRING DIAGRAM (STB-22)

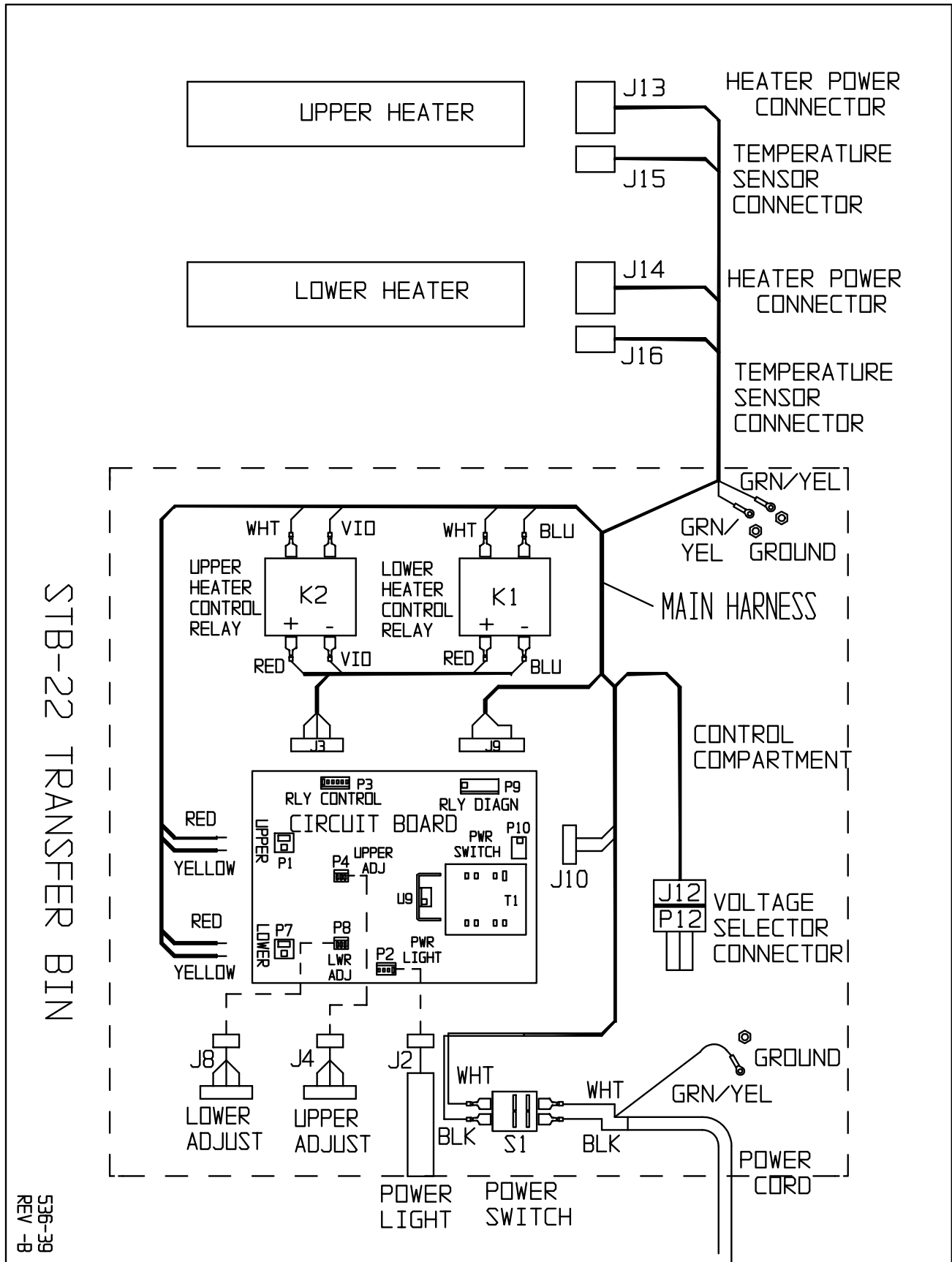

536-39
REV -8