

## OPERATORS MANUAL

This manual provides  
Installation & Operating instructions for

# ***DROP-IN SERIES HEATED WELLS MODELS 9560 & 9570***



### **NOTIFY CARRIER OF DAMAGE AT ONCE.**

It is the responsibility of the consignee to inspect the container upon receipt of same and to determine the possibility of any damage, including concealed damage. Randell suggests that if you are suspicious of damage to make a notation on the delivery receipt. It will be the responsibility of the consignee to file a claim with the carrier. We recommend that you do so at once.

Manufacture Service/Questions 888-994-7636.

Information contained in this document is known to be current and accurate at the time of printing/creation. Unified Brands recommends referencing our product line websites, [unifiedbrands.net](http://unifiedbrands.net), for the most updated product information and specifications.



1055 Mendell Davis Drive  
Jackson, MS 39272  
888-994-7636, fax 888-864-7636  
[randell.com](http://randell.com)

# Contents

FACTORY CORRESPONDENCE	2
SPECIFICATIONS	3
WARRANTY INFORMATION	4
INSTALLATION INSTRUCTIONS	5-7
OPERATION INSTRUCTIONS	8
PREVENTATIVE MAINTENANCE	8
TROUBLESHOOTING	8
REPLACEMENT PARTS	9,10

Congratulations on your recent purchase of Randell food service equipment, and welcome to the growing family of satisfied Randell customers.

Our reputation for superior products is the result of consistent quality craftsmanship. From the earliest stages of product design to fabrication and assembly, rigid standards of excellence are maintained by our staff of designers, engineers, and skilled employees.

Only the finest heavy-duty materials and parts are used in the production of Randell brand equipment. This means that each unit, given proper maintenance, will provide years of trouble free service to its owner.

In addition, all Randell food service equipment is backed by one of the best warranties in the food service industry and by our professional staff of service technicians.

Retain this manual for future reference.

**Notice:** Due to a continuous program of product improvement, Randell Manufacturing reserves the right to make changes in design and specifications without prior notice.

**Notice:** Please read the entire manual carefully before installation. If certain recommended procedures are not followed, warranty claims will be denied.

Model Number \_\_\_\_\_

Serial Number \_\_\_\_\_

Installation Date \_\_\_\_\_

**Randell Manufacturing  
Service and Parts  
Hot Line  
1-800-621-8560  
or for our  
Service Agent Listings  
visit our web site at  
[www.randell.com](http://www.randell.com)**

**UNIT SPECIFICATIONS**

MODEL	LENGTH	DEPTH	12"X20" PAN CAPACITY	CUT OUT SIZE			WATTAGE	AMPERAGE @ 60Hz/1PH (AMPS)			SHIP WGT (LBS)
				UNIT	CONTROL PANEL	# ELEMENTS		120V	208V	240V	
9560-1	18.5"	26"	1	16.5" X 22.63"	14.25" X 5.75"	1	1100	9.2	5.3	4.6	60
9560-2	31.75"	26"	2	30.125" X 22.63"	14.25" X 5.75"	2	2200	18.3	10.6	9.2	85
9560-3	45.5"	26"	3	43.75" X 22.63"	20" X 5.75"	3	3300	27.5	15.9	13.8	103
9560-4	59.25"	26"	4	57.375" X 22.63"	26" X 5.75"	4	4400	36.7	21.2	18.3	170
9560-5	73"	26"	5	71" X 22.63"	32" X 5.75"	5	5500	45.8	26.4	22.9	230
9560-6	86.75"	26"	6	84.625" X 22.63"	38" X 5.75"	6	6600	55	31.7	27.5	290

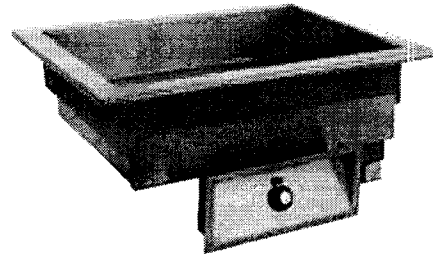
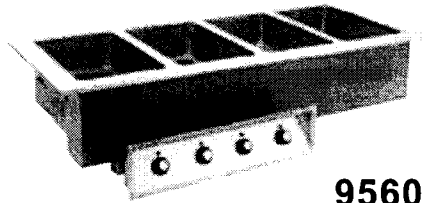

MODEL	LENGTH	DEPTH	12"X20" PAN CAPACITY	CUT OUT SIZE			WATTAGE	AMPERAGE @ 60Hz/1PH (AMPS)		SHIP WGT (LBS)
				UNIT	CONTROL PANEL	# ELEMENTS		208V	240V	
9570-2	31.25"	26"	2	28.25" X 22.63"	14" X 5.75"	1	3000	14.4	12.5	110
9570-3	43.75"	26"	3	40.75" X 22.63"	14" X 5.75"	1	3000	14.4	12.5	135
9570-4	56.5"	26"	4	53.375" X 22.63"	14" X 5.75"	2	6000	28.8	25	160
9570-5	69.25"	26"	5	66.25" X 22.63"	14" X 5.75"	2	6000	28.8	25	185
9570-6	82"	26"	6	79.9375" X 22.63"	14" X 5.75"	2	6000	28.8	25	210

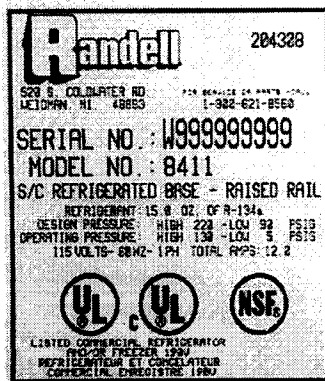

**RANDELL MANUFACTURING  
SERIAL NUMBER LOCATION  
FOR THE  
DROP-IN SERIES**

This is a sample of a serial number tag. The serial number tag on the Drop-In series is located on the control panel.

## Warranty Policies

### Parts Warranty

Randell warrants all component parts of manufactured new equipment to be free of defects in material and workmanship, and that the equipment meets or exceeds reasonable industry standards of performance for a period of one year from the date of shipment from any Randell factory, assembly plant or warehouse facility.

**Note: Warranties are effective from date of shipment, with a thirty day window to allow for shipment, installation and set up. In the event equipment was shipped to a site other than the final installation site, Randell will warranty for a period of three months following installation, with proof of starting date, up to a maximum of eighteen months from date of purchase.**

Component parts warranty does not cover glass breakage. Randell covers all shipping cost related to component part warranty sent at regular ground rates (UPS, USPS). **Freight or postage incurred for any express or specialty methods of shipping are the responsibility of the customer.**

### Labor Coverage

In the unlikely event a Randell manufactured unit fails due to defects in materials or workmanship within the first ninety days, Randell agrees to pay reasonable labor costs incurred. During the first ninety days work authorizations are not required for in warranty repairs. However, repair times are limited to certain flex rate schedules and hours will be deducted from service invoices if they exceed allowed times without prior approval and a work authorization number. Warranties are effective from date of shipment with a 30 day window to allow for shipment, installation, and setup.

When equipment is shipped to a site other than final installation Randell will honor the labor warranty for a period of ninety days following installation with proof of starting date, up to a maximum of nine months from date of purchase. Travel time is limited to one hour each direction or two hours per invoice.

**Any travel time exceeding two hours will be the responsibility of the customer.**

### Export Warranty

Our export warranties will cover all non-electrical parts for the period of one year from the date of shipment to be free of defects in material or workmanship. Electrical parts are also covered if ordered and operated on 60 Hz. Electrical components, ordered and operated on 50 Hz, are warranted for the first 90 days from shipment only. Service labor is covered for the first 90 days with authorization from factory prior to service. Warranty is automatically initiated 60 days from ship date. Inbound costs on any factory supplied items would be the responsibility of the customer. Adherence to recommended equipment maintenance procedures, according to the owners manual provided with each unit, is required for this warranty to remain in effect, and can have a substantial effect on extending the service life of your equipment. Equipment abuse voids any warranty. Extended warranties are not available for parts or labor on units shipped outside the United States.

### Freight Damage

Any and all freight damage that occurs to a Randell piece of equipment as a result of carrier handling is not considered warranty, and is not covered under warranty guidelines. Any freight damage incurred during shipping needs to have a freight claim filed by the receiver with the shipping carrier (note all damages on freight bill at time of delivery). Internal or concealed damage may fall under Randell's responsibility dependent upon the circumstances surrounding each specific incident and are at the discretion of the Randell in-house service technician.

**NOTICE: FOOD LOSS IS NOT COVERED UNDER WARRANTY**

## **Unit Installation**

### **A. Receiving Shipment**

Upon arrival, examine the exterior of the shipping crate for signs of abuse. It is advisable that the shipping crate be partially removed, in order to examine the cabinet for any possible concealed damages which might have occurred during shipment. If no damages are evident, replace the crate in order to protect the unit during storage and local delivery. If the unit is damaged, the damage should be noted on the delivery slip or bill of lading and signed to that effect. A claim must be filed immediately against the carrier indicating the extent and estimated cost of damage occurred.

### **B. Locating Your New Unit**

The following conditions should be considered when selecting a location for your unit:

1. Floor and Counter top load - The area on which the unit will rest must be free of vibration and suitably strong enough to support the combined weights of the unit plus the maximum product load weight.
2. Clearance - There must be a combined total of at least 3" clearance on all sides of the unit.

### **C. Electrical Supply**

The wiring should be done by a qualified electrician in accordance with local electrical codes. A properly wired, and grounded outlet is required for proper operation. Consult the data plate attached to the control panel for the correct supply voltage and amperage requirements of the unit.

### **D. Installation Checklist**

After the final location of the unit has been determined refer to the following checklist prior to start up:

1. Check all wiring to ensure that there are no kinked, bare, or loose wires.
2. Check that unit fits properly in cabinet and ensure that it is properly leveled.
3. Refer to the front of this manual for serial number location. Please record this information in your manual on page 2 now. It will be necessary when ordering replacement parts or requesting warranty service.
4. Confirm that the unit is holding temperature. Set controls to desired temperature.
5. Check unit for any signs of leaking.

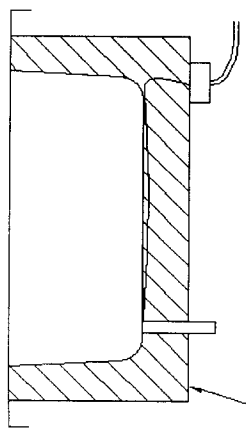
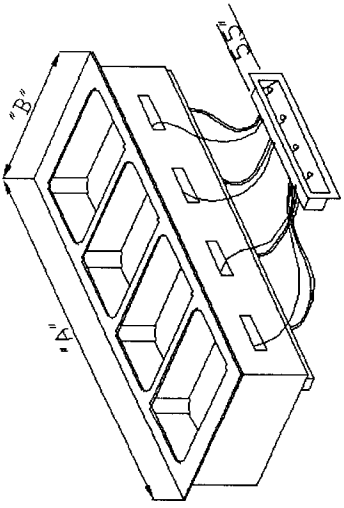

INSULATED OUTER BODY WITH 1/4" FIBER BOARD AROUND OUTER BODY AND FIBERGLASS INSULATION TO FILL ALL SPACING

### IMPORTANT INSTALLATION INSTRUCTIONS

1. WHEN INSTALLING MODEL 9560 DROP-IN HOT FOOD UNIT, A CLEARANCE OF 1/4" ON ALL SIDES AND 4-1/4" BELOW UNIT MUST BE MAINTAINED FROM ALL COMBUSTIBLE MATERIALS.
2. CONTROL PANEL MUST BE INSERTED INTO CUTOUT BEFORE MAIN UNIT IS INSTALLED.
3. SECURE UNIT TO TOP AND SEAL WITH NSF APPROVED SILICON.

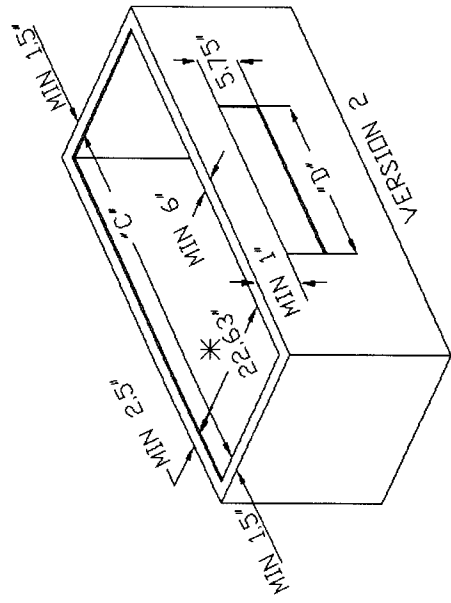
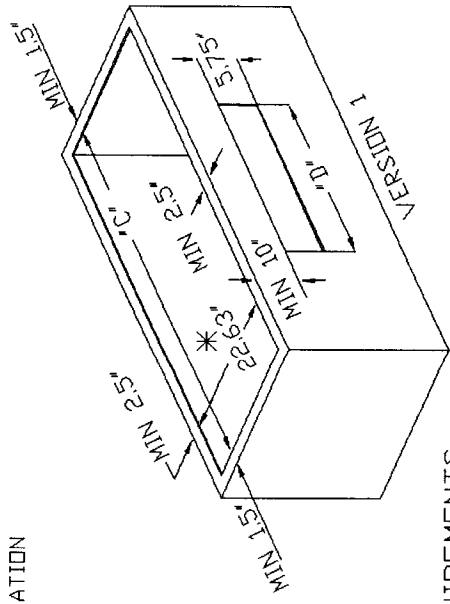

### INSTALLATION REQUIREMENTS:

MODEL	"A"	"B"	"C"	"D"
9560-1	18.5'	26'	16.5'	14.25'
9560-2	31.75'	26'	30.125'	14.25'
9560-3	45.5'	26'	43.75'	20'
9560-4	59.25'	26'	57.375'	26'
9560-5	73'	26'	71'	32'
9560-6	86.75'	26'	84.625'	38'

\* REVISED CUTOUT SIZE FROM 22.5" TO 22.63" 10-18-95  
 \* REVISED CUTOUT SIZE FROM 14" TO 14.25" 6-1-95

# IMPORTANT INSTALLATION INSTRUCTIONS

1. WHEN INSTALLING MODEL 9570 DROP-IN HOT FOOD UNIT, A CLEARANCE OF 1.5" ON ALL SIDES AND 6" CLEARANCE BELOW THE UNIT MUST BE MAINTAINED FROM ALL COMBUSTIBLE MATERIALS.
2. CONTROL PANEL MUST BE INSERTED INTO FRONT CUTOUT BEFORE MAIN UNIT IS INSTALLED.
3. SECURE UNIT TO TOP AND SEAL WITH NSF APPROVED SILICON.

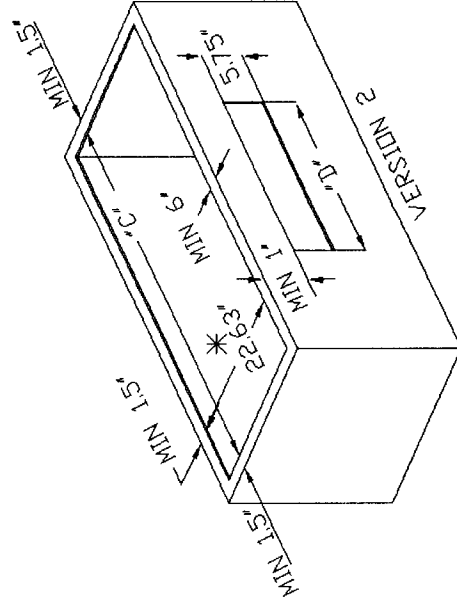
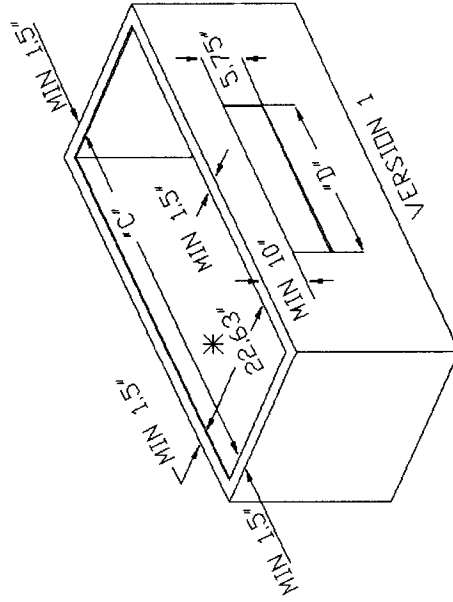
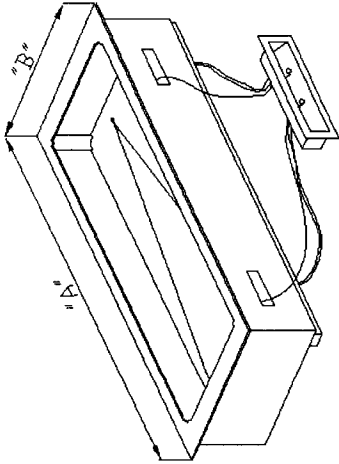

## INSTALLATION REQUIREMENTS:

MODEL	'A'	'B'	'C'	'D'
9570-2	31.25"	26"	28.25"	14"
9570-3	43.75"	26"	40.75"	14"
9570-4	56.5"	26"	53.375"	14"
9570-5	69.25"	26"	66.25"	14"
9570-6	82"	26"	78.9375"	14"

\* REVISED CUTOUT SIZE FROM 22.5" TO 22.63" 10-18-95

## Unit Operation

All units are designed for 145° to 175° operation or 140° to 170° product temperature. When using the unit dry expect at least a 15° drop in product temperatures compared to using it wet. Electric hot food holding units may be operated utilizing water or dry. Wet operation is usually recommended for higher efficiency.

**Plumbing: The units drain must have an outlet to an appropriate drainage area or container.**

**Note: Drains must be plumbed to all applicable local code requirements.**

**Caution: Moisture collecting from improper drainage can create a slippery surface on the floor and a hazard to employees. When making electrical connections refer to the amperage data listed on the units data plate. Your local code or the national electrical code handbook to be sure the unit is connected to the proper power source.**

## Preventive Maintenance

Randell strongly suggests a preventive maintenance program which would include the following procedures:

1. Clean your hot food unit with a solution of warm water and a mild detergent. The stainless steel portion of your unit can be polished with any quality polish.
2. Drain water from wells daily and wipe them out. Clean wells thoroughly twice a week to help insure a longer life for your wells.

**Note: Do not use chemicals, steel wool or scrapers to clean unit.**

**Caution: Do not use abrasive cleaning solvents.**

Proper maintenance of equipment is necessary to prevent costly repairs. By evaluating each unit on a regular schedule you can often catch and repair minor problems before they completely disable the unit. For more information on preventive maintenance consult your local service company or [www.CFESA.com](http://www.CFESA.com). Most repair companies offer this service at very reasonable rates to allow you the time you need to run your business along with the peace of mind that all your equipment will last throughout its expected life. These services often offer guarantees as well as the flexibility in scheduling of maintenance for your convenience. Randell believes strongly in the products it manufacturers and backs those products with one of the best warranties in the industry. We believe with the proper maintenance and use you will realize a profitable return on your investment and years of satisfied service.

## Troubleshooting Guide for Electric Hot Food Drop Ins

An electric hot food table operates on 120V, 208V or 240V circuits. It draws power through either a fuse or circuit breaker panel; if you suspect an electrical problem, check there first. The heating elements are controlled by electrical temperature controls which sense and regulate temperature.

The following trouble shooting guide list the most common malfunctions in order from most to least likely.

PROBLEM	POSSIBLE CAUSE	REMEDY
Unit will not heat	1. Thermostat off	1. Turn on
	2. Unit unplugged	2. Plug in unit
	3. Circuit breaker tripped	3. Replace breaker
	4. Unknown problem	4. Call preferred service agency
Individual well will not heat	1. Thermostat off	1. Turn on
	2. Unknown	2. Call preferred service agency



# 9560 DROP IN HOT FOOD TABLE

ITEM	DESCRIPTION	PART NUMBER
1	CONTROL KNOB	HD KNB003
2	TEMPERATURE CONTROLLER	EL HFT0100
3	INDICATOR LIGHT	EL LGT500
4A	PAN, 12X20 SS W/DRAIN	RP PAN9560WD
4B	PAN, 12X20 SS, W/OUT DRAIN	RP PAN9560ND
5A	ELEMENT, 120V	RP ELM9560A
5B	ELEMENT, 208V	RP ELM9560B
5C	ELEMENT, 240V	RP ELM9560C
6A	ELEMENT PAN ASSY W/120V ELEMENT	RP PAN014
6B	ELEMENT PAN ASSY W/204V ELEMENT	RP PAN015
6C	ELEMENT PAN ASSY W/240V ELEMENT	RP PAN016
6D	ELEMENT PAN ASSY W/OUT ELEMEN	RP PAN017
7	VALVE, 3/4" FPT GATE	PB VLV752
8	DRAIN STRAINER	RP DSN001

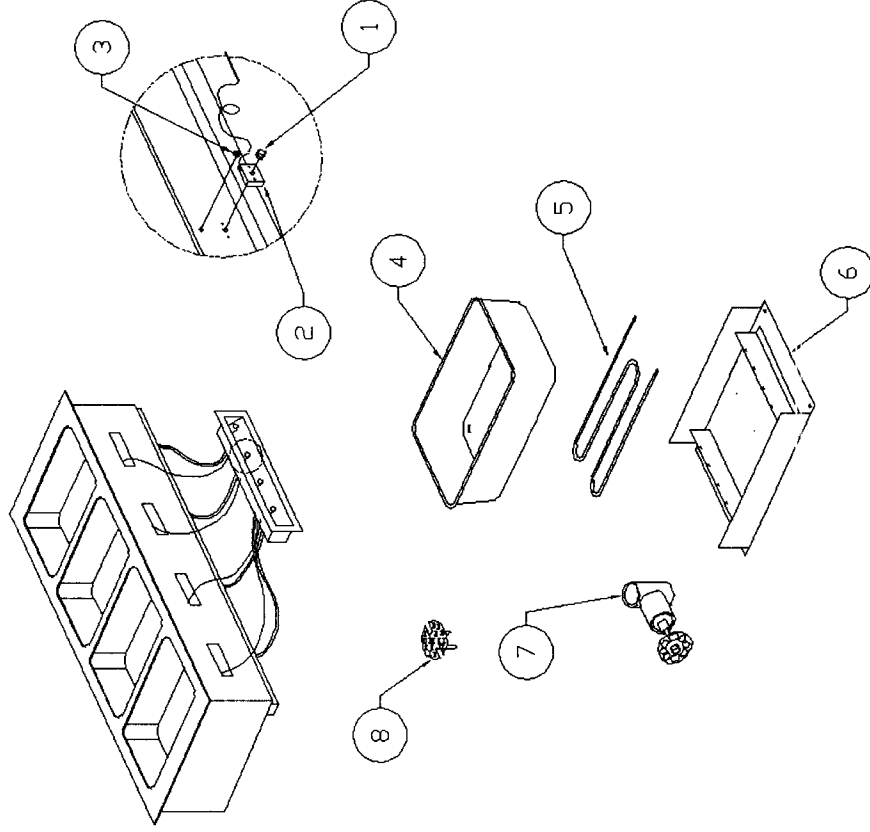

# 9570 REPLACEMENT PARTS

ITEM	DESCRIPTION	PART NUMBER
1	CONTROL KNOB	HD KNB003
2	TEMPERATURE CONTROLLER	EL HFT0100
3	INDICATOR LIGHT	EL LGT500
4	DRAIN STRAINER	RP DSN001
5A	ELEMENT, 208V, 3000W	RP ELM3208
5B	ELEMENT, 240V, 3000W	RP ELM3240
6A	ELEMENT PAN -- 9570-2	RP PAN008
6B	ELEMENT PAN -- 9570-3	RP PAN009
6C	ELEMENT PAN -- 9570-4	RP PAN011
6D	ELEMENT PAN -- 9570-5	RP PAN012
6E	ELEMENT PAN -- 9570-6	RP PAN013
7	VALVE, 3/4" FPT GATE	PB VLV752
8	DIVIDER BAR, 20"	RP BAR0100

