

## OPERATORS MANUAL

This manual provides  
Installation & Operating instructions for

# ***DROP-IN SERIES COLD PANS***



### **NOTIFY CARRIER OF DAMAGE AT ONCE.**

It is the responsibility of the consignee to inspect the container upon receipt of same and to determine the possibility of any damage, including concealed damage. Randell suggests that if you are suspicious of damage to make a notation on the delivery receipt. It will be the responsibility of the consignee to file a claim with the carrier. We recommend that you do so at once.

Manufacture Service/Questions 888-994-7636.

Information contained in this document is known to be current and accurate at the time of printing/creation. Unified Brands recommends referencing our product line websites, [unifiedbrands.net](http://unifiedbrands.net), for the most updated product information and specifications.



**1055 Mendell Davis Drive  
Jackson, MS 39272  
888-994-7636, fax 888-864-7636  
[randell.com](http://randell.com)**

## TABLE OF CONTENTS

Page 2 .....	Congratulations
Page 2 .....	Factory Correspondence
Page 3 .....	Serial Number Location
Page 3.....	Unit Specifications
Page 5 .....	Randell Limited Warranty
Page 6 .....	Unit Installation
Page 8 .....	Unit Operation
Page 9.....	Preventative Maintenance
Page 10.....	Troubleshooting
Page 15 .....	Part Figures

Congratulations on your recent purchase of Randell food service equipment, and welcome to the growing family of satisfied Randell customers.

Our reputation for superior products is the result of consistent quality craftsmanship. From the earliest stages of product design, to successive steps in fabrication and assembly, rigid standards of excellence are maintained by our staff of designers, engineers, and skilled employees.

Only the finest heavy-duty materials and parts are used in the production of Randell brand equipment. This means that each unit, given proper maintenance, will provide years of trouble free service to its owner.

In addition, all Randell food service equipment is backed by one of the best warranties in the food service industry and by our professional staff of service technicians.

Retain this manual for future reference.

**Notice:** Due to a continuous program of product improvement, Randell Manufacturing reserves the right to make changes in design and specifications without prior notice.

**Notice:** Please read the entire manual carefully before installation.

If certain recommended procedures are not followed, warranty claims will be denied.

Model Number \_\_\_\_\_  
Serial Number \_\_\_\_\_  
Installation Date \_\_\_\_\_

**Randell Manufacturing  
Service and Parts  
Hot Line  
1-800-621-8560  
or for our  
Service Agent Listings  
visit our web site at:  
[www.randell.com](http://www.randell.com)**

**RANDELL MANUFACTURING  
SERIAL NUMBER LOCATION  
FOR THE  
DROP-IN SERIES**

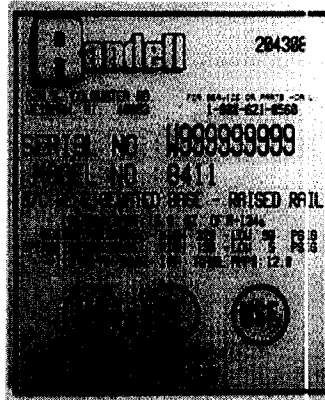

This is a sample of a serial number tag.

The serial number tag on the Non refrigerated Drop-In series is located on body of the unit. On the refrigerated units it is located on the mechanical base by the compressor.

### UNIT SPECIFICATION 9550 SERIES

Model	Length	Depth	No. of Openings	Storage Cu. Ft.	Gallon Capacity	Counter Cutout Dim.	HP	Volt	Amp	NEMA	Ship Wt.
9550A	28 1/2"	17 1/4"	2	1.8	6	26 1/2" x 15 3/4"	1/4	115	6.3	5-15P	125
9552A	28 1/2"	30"	4	3.6	12	26 1/2" x 28"	1/4	115	6.3	5-15P	165

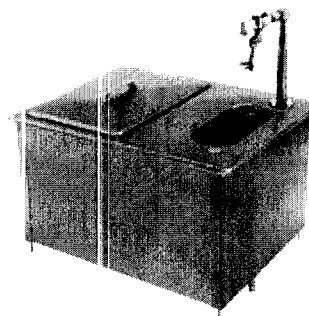
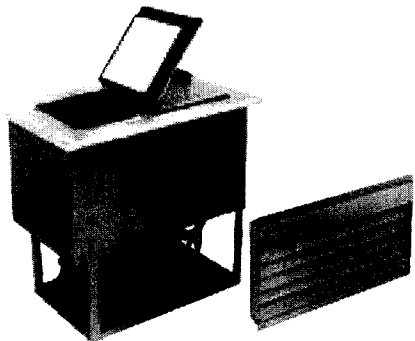

### UNIT SPECIFICATIONS FOR 9500 SERIES

Model	L	D	Cut out Dimensions	Ice Capacity
9500	23"	17 3/4"	21 3/8" x 16 3/8"	60 lbs.
9510	21"	14 5/8"	19 1/2" x 13"	40 lbs.
9505	23 3/4"	20"	22 1/2" x 18 1/2"	44 lbs.
9515	21 3/4"	15 1/8"	20 1/2" x 14"	43 lbs.
9510IC	21"	12 1/2"	19 1/2" x 13 1/2"	60 lbs.
9500IC	23"	17 3/4"	21 3/8" x 16 3/8"	40 lbs.

UNIT SPECIFICATIONS 9700, 9800, 9900 SERIES

Model	12" X 20" Pan Capacity	O/A Flange Length	O/A Flange Width	Counter Cut Out Length	Cut Ou Width	HP	Volts	Amps	NEMA	Ship Wt
9718IC	1	18 1/8"	26"	15 1/4"	22 5/8"	N/A	N/A	N/A	N/A	30
9728IC	2	31"	26"	28 1/4"	22 5/8"	N/A	N/A	N/A	N/A	85
9743IC	3	43 3/4"	26"	41"	22 5/8"	N/A	N/A	N/A	N/A	110
9757IC	4	56 1/4"	26"	55"	22 5/8"	N/A	N/A	N/A	N/A	125
9772IC	5	71 1/4"	26"	70"	22 5/8"	N/A	N/A	N/A	N/A	145
9786IC	6	85 1/4"	26"	84"	22 5/8"	N/A	N/A	N/A	N/A	165
9828SCA	N/A	30"	26"	26 1/4"	22 1/2"	1/4	115	5	5-15p	140
9843SCA	N/A	43"	26"	39 1/4"	22 1/2"	1/3	115	6.5	5-15p	175
9857SCA	N/A	56 3/4"	26"	53"	22 1/2"	1/3	115	6.5	5-15p	210
9872SCA	N/A	71 3/4"	26"	68"	22 1/2"	1/3	115	6.5	5-15p	245
9886SCA	N/A	85 3/4"	26"	82"	22 1/2"	1/2	115	8	5-15p	280
9918SCA	1	17 1/2"	26"	16"	24 3/4"	1/4	115	7.1	5-15p	110
9928SCA	2	30 3/8"	26"	29"	24 3/4"	1/4	115	7.1	5-15p	140
9943SCA	3	43 5/16"	26"	42"	24 3/4"	1/4	115	7.1	5-15p	175
9957SCA	4	56 1/4"	26"	54 3/4"	24 3/4"	1/4	115	7.1	5-15p	210
9972SCA	5	69 1/8"	26"	67 3/4"	24 3/4"	1/4	115	7.1	5-15p	245
9986SCA	6	82"	26"	80 1/2"	24 3/4"	1/4	115	7.1	5-15p	280
9946SCN	2	46"	18 5/16"	44 3/4"	17"	1/4	115	7.1	5-15p	140
9966SCN	3	66 3/4"	18 5/16"	65 7/16"	17"	1/4	115	7.1	5-15p	175
9987SCN	4	87 1/2"	18 5/16"	86 3/16"	17"	1/4	115	7.1	5-15p	210

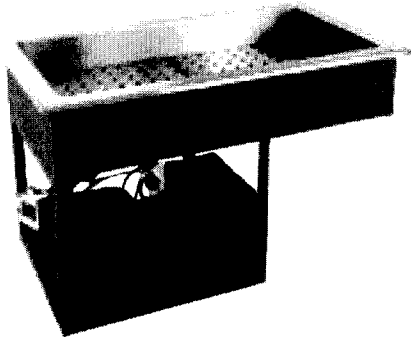

9770SCA SERIES

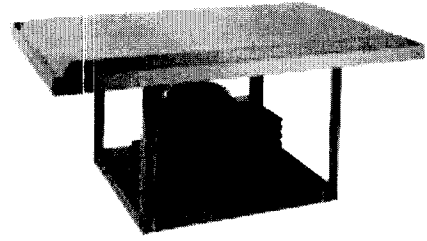

9800 SERIES

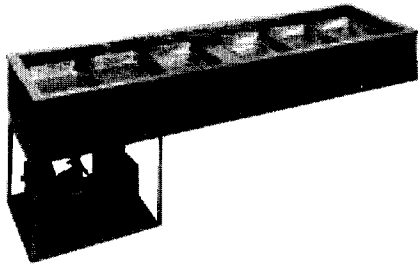

9900SCA SERIES

## Warranty Policies

### Parts Warranty

Randell warrants all component parts of manufactured new equipment to be free of defects in material or workmanship, and that the equipment meets or exceeds reasonable industry standards of performance for a period of one year from the date of shipment from any Randell factory, assembly plant or warehouse facility.

**Note: Warranties are effective from date of shipment, with a thirty day window to allow for shipment, installation and set up. In the event equipment was shipped to a site other than the final installation site, Randell will warranty for a period of three months following installation, with proof of starting date, up to a maximum of eighteen months from date of purchase.**

Component parts warranty does not cover glass breakage or gasket replacement. Randell covers all shipping cost related to component part warranty sent at regular ground rates (UPS, USPS). **Freight or postage incurred for any express or specialty methods of shipping are the responsibility of the customer.**

### Labor Coverage

In the unlikely event a Randell manufactured unit fails due to defects in materials or workmanship within the first ninety days, Randell agrees to pay reasonable labor incurred. During the first ninety days work authorizations are not required for in warranty repairs. However, repair times are limited to certain flex rate schedules and hours will be deducted from service invoices if they exceed allowed times without prior approval and a work authorization number. Warranties are effective from date of shipment, with a 30 day window to allow for shipment, installation and setup.

Where equipment is shipped to any site other than final installation Randell will honor the labor warranty for a period of ninety days following installation with proof of starting date, up to a maximum of nine months from date of purchase. Travel time is limited to one hour each direction or two hours per invoice.

**Any travel time exceeding two hours will be the responsibility of the customer.**

**Note:** Temperature adjustments are not covered under warranty, due to the wide range of ambient conditions.

### Five Year Extended Compressor Warranty

United States installations only:

Randell will pay for the replacement compressor only. Freight, labor, refrigerant, handling and all other miscellaneous charges are the responsibility of the customer. Randell will fulfill its warranty obligation by using one of the four methods provided below, which will be selected by the Randell in-house service technician:

1. Provide reimbursement to servicing customer for the cost of the locally obtained replacement compressor in exchange for the return of the defective compressor returned to Randell freight prepaid. Randell does limit the amount of reimbursement allowed and does require a copy of the local supply house bill for replacement compressor.

**Customer should not pay servicing agent up front for compressor.**

2. Provide repair at the manufacturing facility by requiring that the defective unit be sent back to Randell freight prepaid. Perform repair at the expense of Randell and ship the item back to job location freight collect.
3. Furnish a replacement compressor freight collect in exchange for the return of the defective compressor sent back freight prepaid.
4. Furnish complete condensing unit or replacement package freight collect in exchange for the return of the defective compressor sent back freight prepaid. (decisions based on whether or not to send complete condensing unit will be made by Randell in-house service technician).

### Export Warranty

Our export warranties will cover all non electrical parts for the period of one year from the date of shipment to be free of defects in material or workmanship. Electrical parts are also covered if ordered and operated on 60 Hz. Electrical components, ordered and operated on 50 Hz, are warranted for the first 90 days from shipment only. Service labor is covered for the first 90 days with authorization from factory prior to service. Warranty is automatically initiated 60 days from ship date. Inbound costs on any factory supplied items would be the responsibility of the customer. Adherence to recommended equipment maintenance procedures, according to the owners manual provided with each unit, is required for this warranty to remain in effect, and can have a substantial effect on extending the service life of your equipment. Equipment abuse voids any warranty. Extended warranties are not available for parts, labor or compressors on units shipped outside the United States.

## **Freight Damage**

Any and all freight damage that occurs to a Randell piece of equipment as a result of carrier handling is not considered warranty, and is not covered under warranty guidelines. Any freight damage incurred during shipping needs to have a freight claim filed by the receiver with the shipping carrier (note all damages on freight bill at time of delivery). Internal or concealed damage may fall under Randell's responsibility dependent upon the circumstances surrounding each specific incident and are at the discretion of the Randell in-house service technician.

## **NOTICE: FOOD LOSS IS NOT COVERED UNDER WARRANTY**

## **Unit Installation**

### **A. Receiving Shipment**

Upon arrival, examine the exterior of the shipping crate for signs of abuse. It is advisable that the shipping crate be partially removed, in order to examine the cabinet for any possible concealed damages which might have occurred during shipment. If no damages are evident, replace the crate in order to protect the unit during storage and local delivery. If the unit is damaged, it should be noted on the delivery slip or bill of lading and signed to that effect. A claim must be filed immediately against the carrier indicating the extent and estimated cost of damage occurred.

### **B. Locating Your New Unit**

The following conditions should be considered when selecting a location for your unit:

1. Floor and Counter top load - The area on which the unit will rest must be free of vibration and suitably strong enough to support the combined weights of the unit plus the maximum product load weight.
2. Clearance - There must be a combined total of at least 3" clearance on all sides of the unit.
3. Ventilation - The air cooled self contained unit requires a sufficient amount of cool clean air. Avoid placing the unit near heat generating equipment such as ovens, ranges, heaters, fryers, steam kettles, etc. and out of direct sunlight. Avoid locating the make table in an unheated room or where the room temperature may drop below 55° F or above 90° F. Our drop in cold pans need cross flow ventilation with at least 336 square inches per opening.



### **C. Electrical Supply**

The wiring should be done by a qualified electrician in accordance with local electrical codes. A properly wired, and grounded outlet will assure proper operation. Please consult the data plate attached to the compressor to ascertain the correct electrical requirements. Supply voltage and amperage requirements are located on the serial number tag located inside the far left door.

**Note: It is important that a voltage reading be made at the compressor motor electrical connections, while the unit is in operation, to verify that the correct voltage required by the compressor is being supplied. Low or high voltage can detrimentally affect operation and thereby void its warranty.**

**Note: It is important that your unit has its own dedicated line. Condensing units are designed to operate with a voltage fluctuation of plus or minus 10% of the voltage indicated on the unit data plate. Burn out of a condensing unit due to exceeding voltage limits will void the warranty.**

### **D. Installation Checklist**

After the final location of the unit has been determined refer to the following checklist prior to start up:

1. Check all exposed refrigeration lines to ensure that they are not kinked, dented or rubbing together.
2. Check that condenser fans rotate freely without striking any stationary members.
3. Unit must be properly leveled.
4. Plug in unit and turn on main on/off switch.
5. Refer to the front of this manual for serial number location. Please record this information in your manual on page 3 now. It will be necessary when ordering replacement parts or requesting warranty service.
6. Allow your unit to operate for approximately 1 hour before putting in food this allows for a proper frost pattern to form.
7. Confirm that unit is holding temperature. Set controls to desired temperature.

**Note: All motors are oiled and sealed at the factory.**

# IMPORTANT

## FIGURE-1

RECOMMENDED INSTALLATION  
INSTRUCTION FOR SELF-CONTAINED  
DROP-IN COLD PAN.

SECURE UNIT TO TOP  
WITH NSF APPROVED SILICON

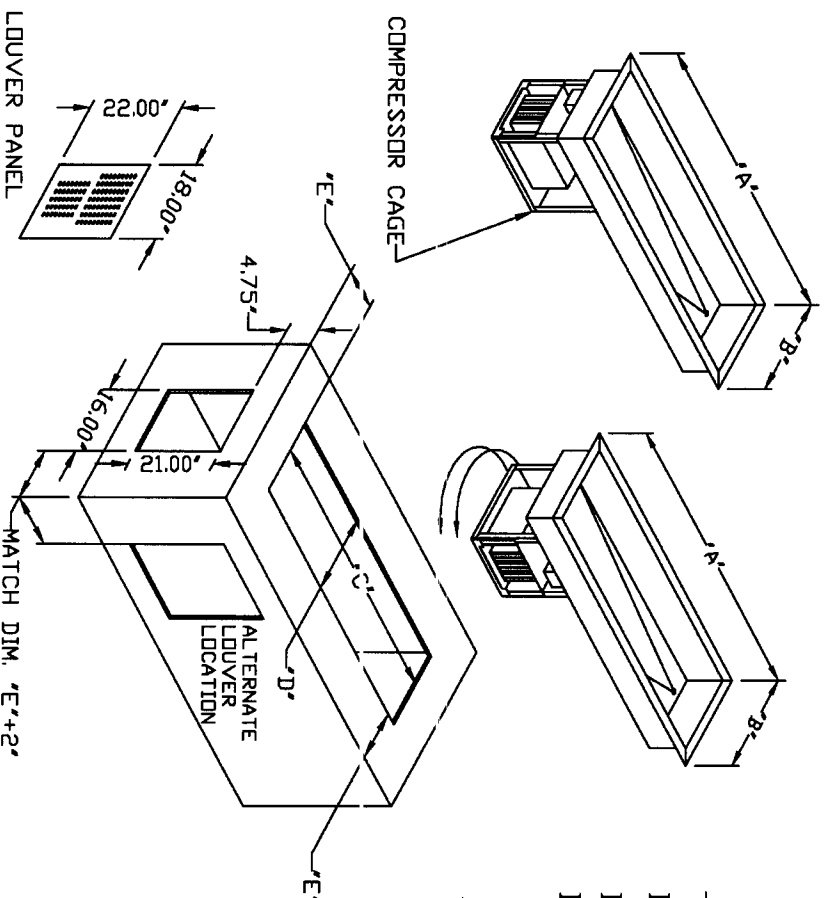

MODEL	'A'	'B'	'C'	'D'
9718-SCA	18.125'	26'	15.25'	22.625'
9728-SCA	31'	26'	28.25'	22.625'
9743-SCA	43.75'	26'	41'	22.625'
9757-SCA	56.25'	26'	55'	22.625'
9772-SCA	71.25'	26'	70'	22.625'
9786-SCA	85.25'	26'	84'	22.625'

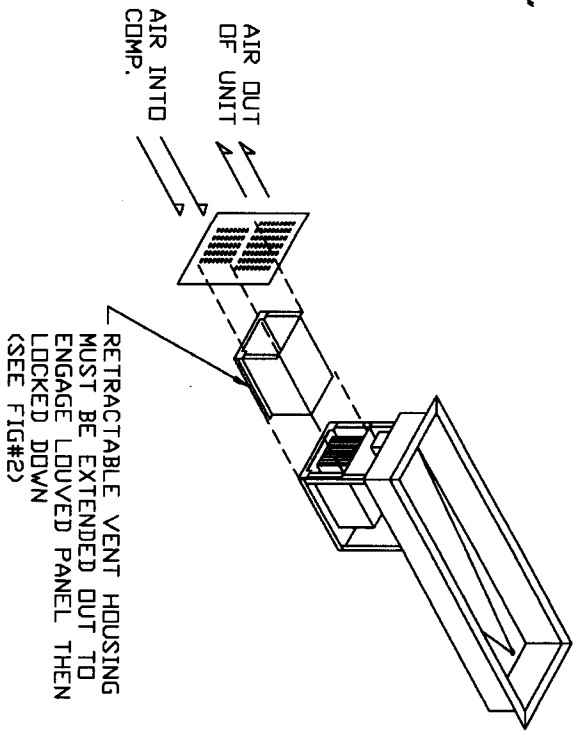

DESCRIPTION: INSTALLATION INSTRUCTIONS  
9700SC SERIES COLD PAN DROP-IN

g:\PDR\PDR\_DWG\TITLEBLD\RPB

LATEST REV	DATE	BY	FILE NO.
DRAWER	5/27/00	JASON B	320 SOUTH COLDWATER ROAD WEDDAM, MICHIGAN 48853
LATER REV	APPROVED BY:	SCALE	FILE NAME
		N/A	

# IMPORTANT

## FIGURE-1

RECOMMENDED INSTALLATION  
INSTRUCTION FOR SELF-CONTAINED  
DROP-IN COLD PAN.

SECURE UNIT TO TOP  
WITH NSF APPROVED SILICON

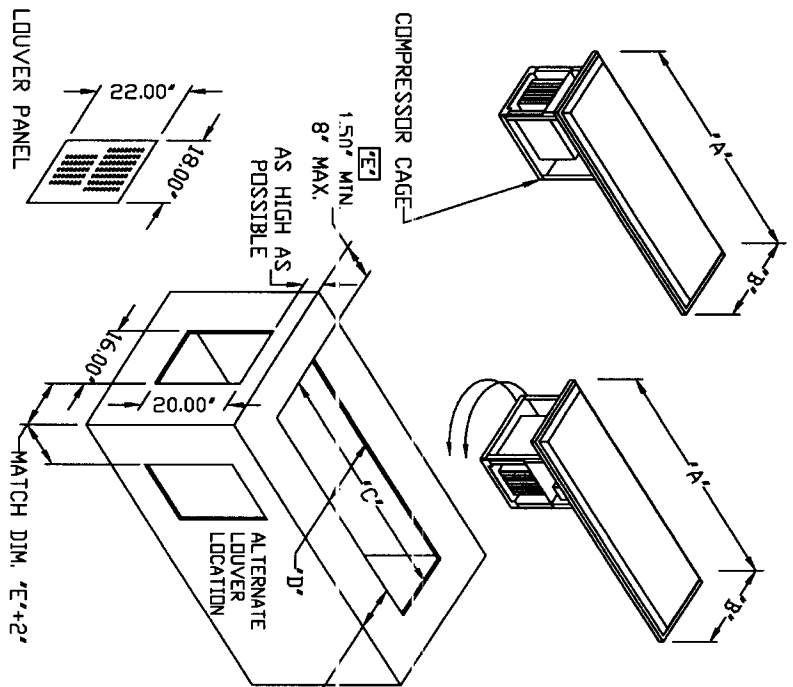

MODEL	'A'	'B'	'C'	'D'
9828-SCA	30'	26'	26.25'	20.50'
9843-SCA	43'	26'	39.25'	20.50'
9857-SCA	56.75'	26'	53'	20.50'
9872-SCA	71.75'	26'	68'	20.50'
9886-SCA	85.75'	26'	82'	20.50'

DESCRIPTION: INSTALLATION INSTRUCTIONS  
9800SC SERIES FROST TOP DROP-IN

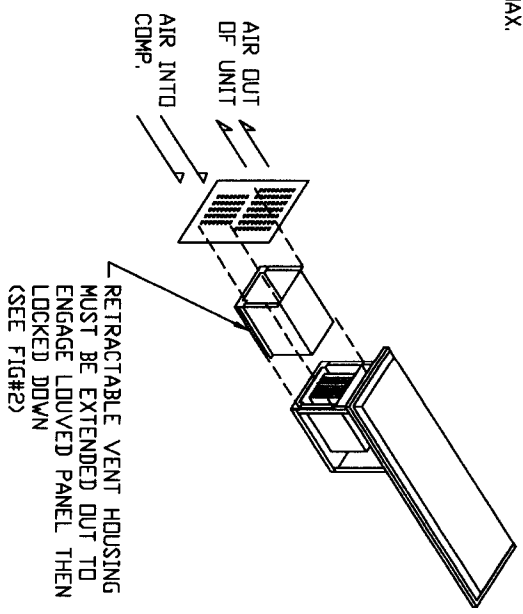

DATE	REVISION	BY	FILE NO.
5/27/00	LATEST REV	JASON B	530 SOUTH COLUMBIA ROAD WEDDAR, MICHIGAN 48893
	DRAWN		
	LATER REV		
	APPROVED BY:		
	SCALE	N/A	

# IMPORTANT

## FIGURE-1

RECOMMENDED INSTALLATION INSTRUCTION FOR SELF-CONTAINED DROP-IN COLD PAN.

- 1: DETERMINE LOCATION OF AIR INTAKE AND EXHAUST OPTION **S** OR **R**
- 2: SECURE UNIT TO TOP WITH NSF APPROVED SILICON
- 3: INSTALL LOUVER (18"X22") MIN

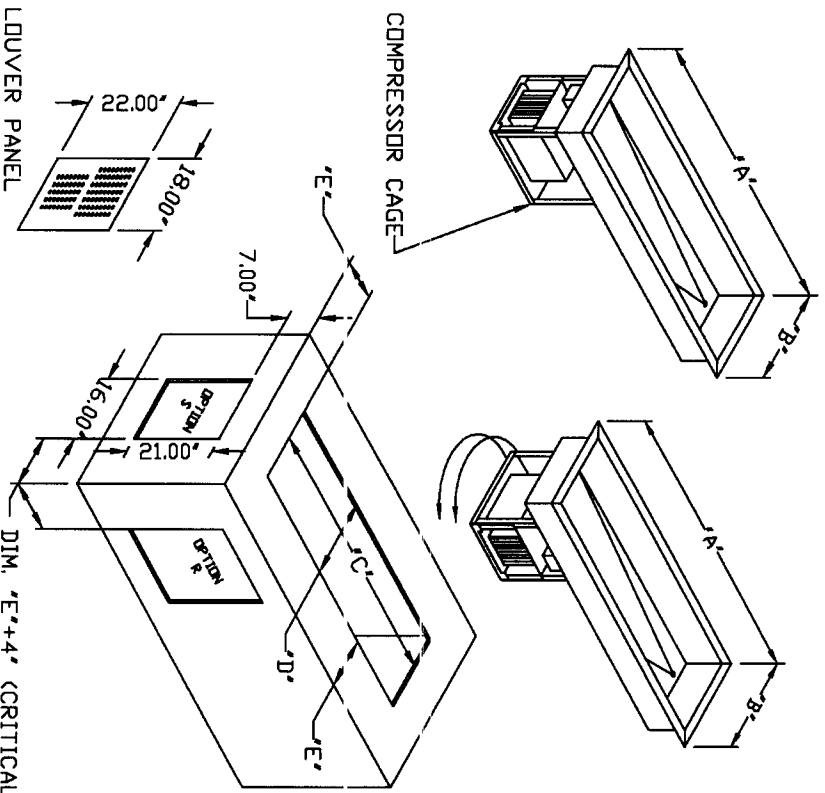
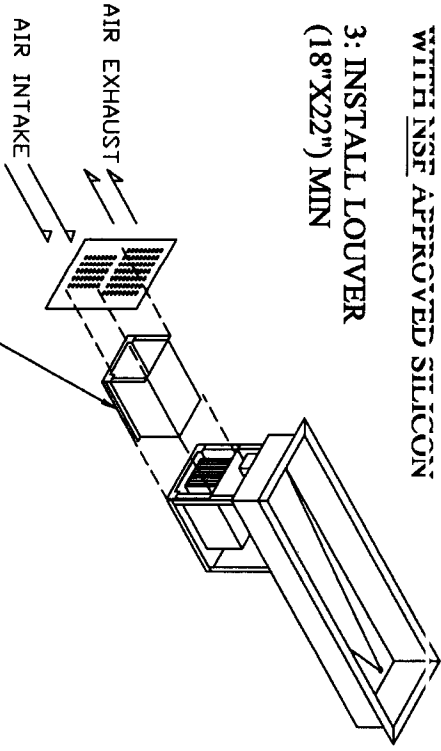

MODEL	'A'	'B'	'C'	'D'	'E'
9918-SCA	17.5'	26'	16'	24.75'	1.5'-7.5'
9928-SCA	30.375'	26'	29'	24.75'	-
9943-SCA	43.3125'	26'	42'	24.75'	-
9957-SCA	56.25'	26'	54.75'	24.75'	-
9972-SCA	69.125'	26'	67.75'	24.75'	-
9986-SCA	82'	26'	80.5'	24.75'	-

DESCRIPTION: INSTALLATION INSTRUCTIONS  
9900SCA SERIES COLD PAN DROP-IN

0:\PDT\PDT\_DMG\TITLEBLD\RPB

LATEST REV	DATE	APPROVED BY:	SCALE	BY	FILE NO.
DRAWER	5/27/00		N/A	JASON B	520 SOUTH COLDWATER ROAD WELLS, MICHIGAN 48893
LATER REV					FILE NAME

**FIGURE-2**

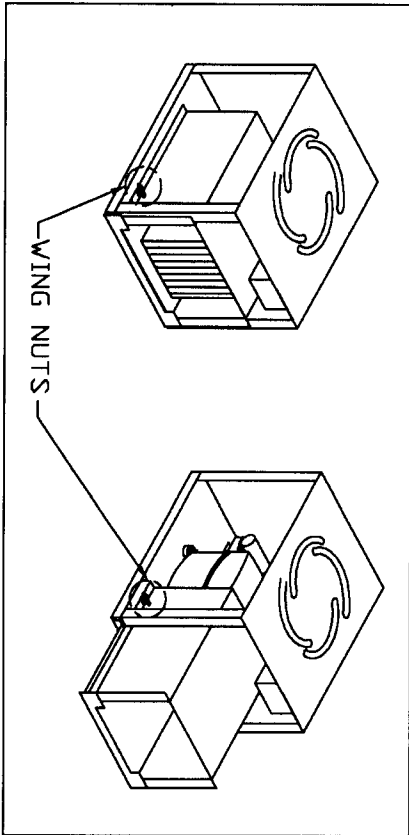
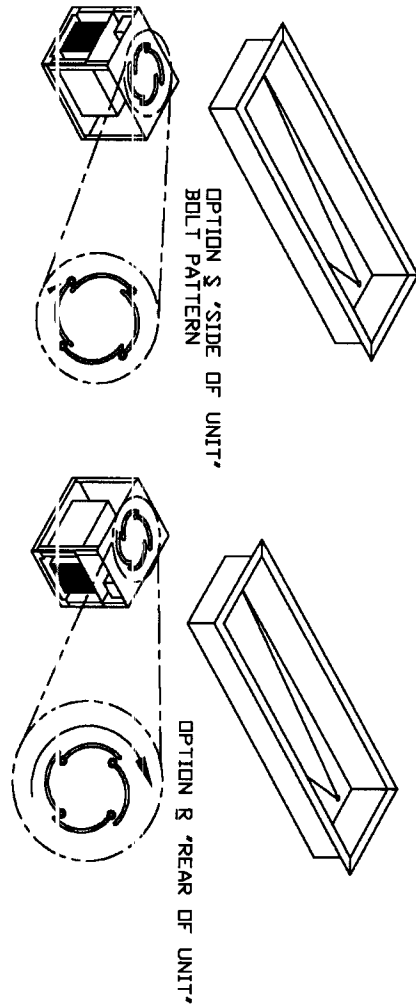

\*TO ROTATE LOOSEN 4 MOUNTING BOLTS ON TOP OF COMPRESSOR CAGE 1 1/2 TURNS THEN HOLD COMPRESSOR CAGE BY THE FRAME AND ROTATE 90° TO DESIRED POSITION RETIGHTEN BOLTS

\*TO EXTEND VENT HOUSING REMOVE LOUVER AND LOOSEN WING NUTS LOCATED ON THE SIDE OF HOUSING. NOW EXTEND THE HOUSING UNTIL IT ENGAGES THE LOWERED OPENING. FINGER TIGHTEN WING NUTS, THEN REINSTALL LOUVER.

DESCRIPTION: INSTALLATION INSTRUCTIONS  
VENT HOUSING AND COMP. ROTATION

0:\PDT\PDT\_DWG\TITLEBLOCK\PRIB

LATEST REV	DATE	BY	FILE NO.
DRAWER	5/27/00	JASON B	520 SOUTH COLDWATER ROAD WEIDMAN, MICHIGAN 48893
LATER REV	APPROVED BY:	SCALE	FILE NAME
		N/A	

## Figure B - Temperature control adjustments

The control knob allows for temperature adjustments by turning the knob clockwise will result in increased cooling. Keep the arrow on the knob pointed within the green arc. Turning it clockwise beyond the green can result in freeze-up, while turning it counterclockwise beyond the green will shut the compressor off. If your cold pan temperature remains to warm and your temperature control is at the maximum setting please contact your factory technician. On units containing a pressure control device make sure that proper temperature/pressure settings are achieved at the time of installation by a qualified installation contractor. If minor adjustments are needed at a later date, adjust control by turning the temperature cut-in adjusting screw clockwise (1/4 turn at a time) to a lower number for colder temperature and counterclockwise to a higher number for warmer temperature.

**Note: Numbers are pounds of pressure not degrees F.**

**Note: Do not adjust the differential screw.**

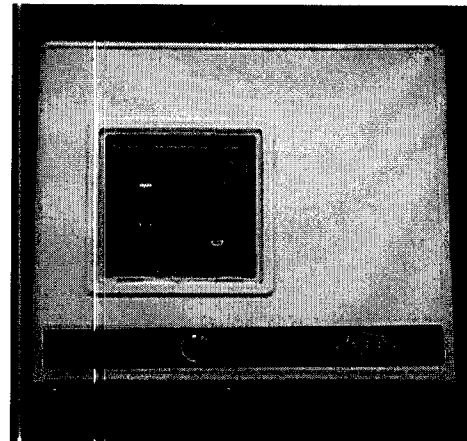

## Unit Operation

Randell has attempted to preset the cold control for an average temperature at the factory but due to varying ambient conditions, including elevation, food product as well as type of operation you may need to alter this temperature. Additional adjustments can be made (within limits) by turning the control dial up or down until the desired temperature is reached. The control dial is located on the unit base by the compressor.

### Morning Startup

1. Rail cleaning may be performed at this time.
2. Once rail is clean and prepared for product, turn on the unit with the switch located on the base by the compressor.
3. Allow 25 minutes unit to cool down before loading product. (If the unit is starting from a full off position, 30-45 minutes may be necessary for the unit to cool down).
4. Load the product and proceed with food preparation.

### Evening Shut Down

1. Remove product from the rail at the end of the day's preparation.
2. Turn off the rail with the switch located on the base by the compressor.
3. Cleaning maybe performed at this time if the frost has melted off the rail surfaces.

## Preventive Maintenance

Randell strongly suggests a preventive maintenance program which would include the following **Monthly** procedures:

1. Cleaning of all condenser coils. Condenser coils are a critical component in the life of the compressor and must remain clean to assure proper air flow and heat transfer. Failure to maintain this heat transfer will affect unit performance and eventually destroy the compressor. Clean the condenser coils with approved coil cleaner and/or a vacuum cleaner and brush.

**Note: Brush coil in direction of fins, normally vertically as to not damage or restrict air flow from passing through condenser.**

**NOTE: DO NOT USE SHARP UTENSILS**

2. Clean all fan blades
3. Stainless steel surfaces should be cleaned daily.

Recommended cleaners for your stainless steel include the following:

JOB	CLEANING AGENT	COMMENTS
Routine cleaning	Soap, ammonia, detergent Medallion	Apply with a sponge or cloth
Fingerprints and smears	Arcal 20, Lac-O-Nu, Ecoshine	Provides a barrier film
Stubborn stains and discoloration	Cameo, Talc, Zud, First impression	Rub in the direction of the polish lines
Greasy and fatty acids, blood, burnt-on foods	Easy-Off, De-grease It, Oven aid	Excellent removal on all finishes
Grease and oil	Any good commercial detergent	Apply with a sponge or cloth
Restoration/Passivation	Benefit, Super Sheen	Good idea monthly

Reference: Nickel Development Institute, DiverseyLever, Savin, Ecolab, NAFEM

Do not use steel pads, wire brushes, scrapers or **chloride cleaners** to clean your stainless steel.

**CAUTION: DO NOT USE ABRASIVE CLEANING SOLVENTS, NEVER USE HYDROCHLORIC ACID (MURIATIC ACID) ON STAINLESS STEEL.**

Proper maintenance of equipment is the ultimate necessity in preventing costly repairs. By evaluating each unit on a regular schedule you can often catch and repair minor problems before they completely disable the unit and become burdensome on your entire operation.

**For more information on preventive maintenance consult your local service company or [www.CFESA.com](http://www.CFESA.com).** Most repair companies offer this service at very reasonable rates to allow you the time you need to run your business along with the peace of mind that all your equipment will last throughout its expected life. These services often offer guarantees as well as the flexibility in scheduling of maintenance for your convenience. Randell believes strongly in the products it manufacturers and backs those products with one of the best warranties in the industry. We believe with the proper maintenance and use you will realize a profitable return on your investment and years of satisfied service.

## TROUBLESHOOTING CHART

SYMPTOM	POSSIBLE CAUSE	PROCEDURE
UNIT DOESN'T RUN	<ol style="list-style-type: none"> <li>1. NO POWER TO UNIT.</li> <li>2. TEMPERATURE CONTROL TURNED OFF.</li> <li>3. TEMPERATURE CONTROL FAULTY.</li> <li>4. COMPRESSOR OVERHEATED.</li> <li>5. CONDENSER FAN FAULTY.</li> <li>6. OVERLOAD PROTECTOR FAULTY.</li> <li>7. COMPRESSOR RELAY FAULTY.</li> <li>8. COMPRESSOR FAULTY.</li> </ol>	<ol style="list-style-type: none"> <li>1. PLUG IN UNIT.</li> <li>2. CHECK TEMPERATURE CONTROL.</li> <li>3. TEST TEMPERATURE CONTROL.</li> <li>4. CLEAN CONDENSER COIL.</li> <li>5. SERVICE CONDENSER FAN MOTOR.</li> <li>6. TEST OVERLOAD.</li> <li>7. TEST RELAY.</li> <li>8. CALL FOR SERVICE AT 1-800-621-8560.</li> </ol>
UNIT SHORT CYCLES	<ol style="list-style-type: none"> <li>1. CONDENSER COIL DIRTY.</li> <li>2. CONDENSER FAN FAULTY.</li> <li>3. COMPRESSOR FAULTY.</li> <li>4. OVERLOAD REPEATEDLY TRIPPING.</li> </ol>	<ol style="list-style-type: none"> <li>1. CLEAN COIL.</li> <li>2. SERVICE FAN AND MOTOR.</li> <li>3. CALL FOR SERVICE AT 1-800-621-8560.</li> <li>4. CHECK OUTLET VOLTAGE.</li> </ol>
UNIT RUNS CONSTANTLY	<ol style="list-style-type: none"> <li>1. FROST BUILD UP.</li> <li>2. CONDENSER COIL DIRTY.</li> <li>3. CONDENSER FAN FAULTY.</li> </ol>	<ol style="list-style-type: none"> <li>1. DEFROST UNIT.</li> <li>2. CLEAN COIL.</li> <li>3. SERVICE CONDENSER MOTOR.</li> </ol>
UNIT NOT COLD ENOUGH	<ol style="list-style-type: none"> <li>1. TEMPERATURE CONTROL SET TOO HIGH.</li> <li>2. TEMPERATURE CONTROL FAULTY.</li> <li>3. CONDENSER COIL DIRTY.</li> <li>4. REFRIGERANT LEAKING OR CONTAMINATED.</li> </ol>	<ol style="list-style-type: none"> <li>1. LOWER SETTING.</li> <li>2. TEST CONTROL.</li> <li>3. CLEAN COIL.</li> <li>4. CALL FOR SERVICE AT 1-800-621-8560.</li> </ol>
UNIT TOO COLD	<ol style="list-style-type: none"> <li>1. TEMPERATURE CONTROL SET TOO LOW.</li> <li>2. TEMPERATURE CONTROL FAULTY.</li> </ol>	<ol style="list-style-type: none"> <li>1. ADJUST CONTROL.</li> <li>2. TEST CONTROL.</li> </ol>



### 1. Cleaning condenser coil.

An accumulation of dirt and dust prevents the condenser coil from removing heat, making your unit cool poorly, run constantly, or even stop completely if the compressor overheats. Clean coil using a vacuum cleaner with a wand attachment. If the coil is greasy, wash it with warm soapy water and a bristle brush, taking care not to drip water on other parts of your unit.

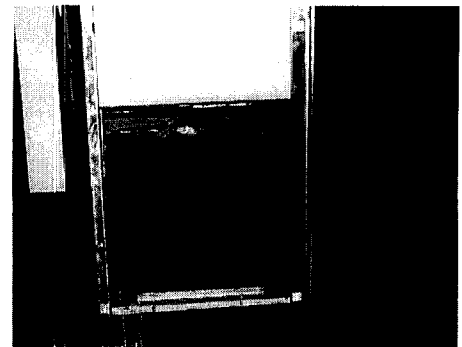

### 2. Testing and replacing the temperature control.

Unplug the unit and remove the temperature control knob. Remove the screws securing the fan shroud to the evaporator coil assembly, next remove the screws securing the temperature control to the fan shroud. Taking care not to bend the capillary line, pull off the wire connectors. Now you are ready to test for continuity.

Set your multimeter at RX1, Touch a probe to each terminal. With the control turned at its highest setting the tester should indicate a closed circuit. Turn off the control then retest; the tester should indicate an open circuit.

To install a new temperature control, pull the capillary line of the old control out of its opening. Set the new control to its coldest setting and carefully thread the capillary line into the opening without kinking it (place end of capillary tube in exactly the same location as the old. Attach the wires to the terminals, screw the control in place and reattach the dial.

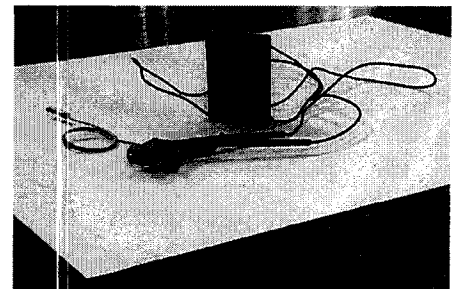

### 3. Servicing the condenser fan.

Unplug the unit. Inspect the condenser fan motor by removing the mechanical housing cover to gain access. Clean the fan blade, and turn it to see if the blade rotates freely. If the motor binds, replace it. If the blade is damaged, unscrew the nut that holds it to the motor shaft and pull it off. Install a new fan blade, replacing any washers, and tighten the nut.

To test the condenser fan motor disconnect the wires to the fan motor. Set a multimeter at RX10 and touch one probe to each terminal. The multimeter needle should show approximately 45 to 50 ohms resistance; a lower reading means the motor is faulty. Next set the meter at RX1000 and touch one probe to the motor terminals and the other one to any unpainted metal part of the unit. If the meter needle moves, the motor is grounded and should be replaced. To remove the motor unscrew the bracket that holds the fan motor to its housing, slide the motor out of the housing. Remove the fan blade from the old motor and attach it to the new motor, replacing any washers. Install the new motor in its housing by screwing the bracket in place. Reattach the wires to the motor terminals.



#### 4. Servicing the compressor.

Unplug the unit. The compressor is part of the sealed refrigeration system and should be replaced by a professional service technician. You can, however, test the compressor and certain components. Remove the access cover to the mechanical housing. A small box mounted on the side of the compressor protects the relay, overload protector and capacitor. Release the wire retaining clip that holds the cover in place and slip off the cover and the clip.

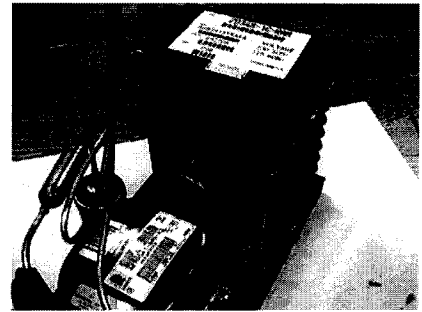

To test the compressor relay pull the relay straight off the compressor without twisting it. If the relay has an external wire coil, hold the relay so that the word top is up. Set the multimeter at RX1 and place the probes on the terminals S and M. the multimeter needle should not move. Next remove the probe from M and place it on the side terminal marked L. once again, the needle should not move. Finally, remove the probe from S and place it on M. the needle should sweep across the scale, showing full continuity. Now turn the relay upside down and perform the same tests. You should get the opposite results: continuity between terminals S and M and between S and L; no continuity between M and L. if the relay fails any of these tests, replace it: push the new relay onto the compressor terminals and replace the terminal cover. If the relay passes these tests, test the overload protector.



To remove the overload protector use a screwdriver to gently pry open the circular spring clip that secures the overload protector to the compressor and snap out the protector. Pull the two wire connectors off their terminals.

To test set a multimeter at RX1 and touch a probe to each overload protector terminal. The multimeter needle should sweep across the scale, showing full continuity. If the overload protector passes this test, test the compressor. If not replace the overload protector. Reattach the push-on connectors to the new overload protector, clip it in place on the compressor and replace the terminal cover.

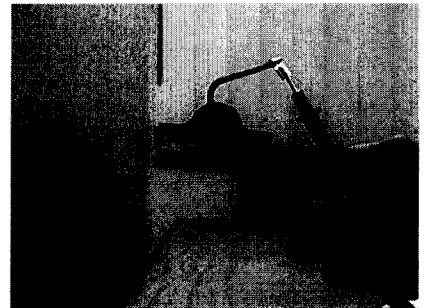

To test the compressor set a multimeter at RX1, test each of the three terminal pins against each of the other two. Each pair should show continuity. Then, with the multimeter set at RX1000, place one probe against the metal housing of the compressor; if necessary, scrape off a little paint to ensure contact with bare metal. Place the other probe on each of the three terminals in turn. If any of the three terminals shows continuity with the housing, the compressor is grounded. If the compressor fails either test, call for service. If it passes the tests, reinstall the overload protector, relay, terminal cover and mechanical housing cover.

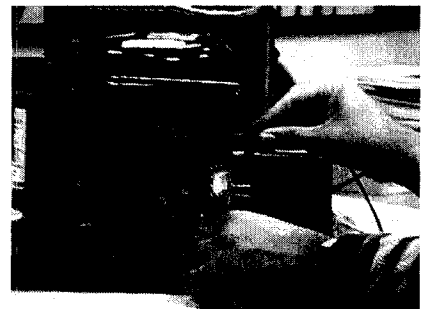

PARTS LIST  
FOR  
RANDELL  
DROP-IN SERIES

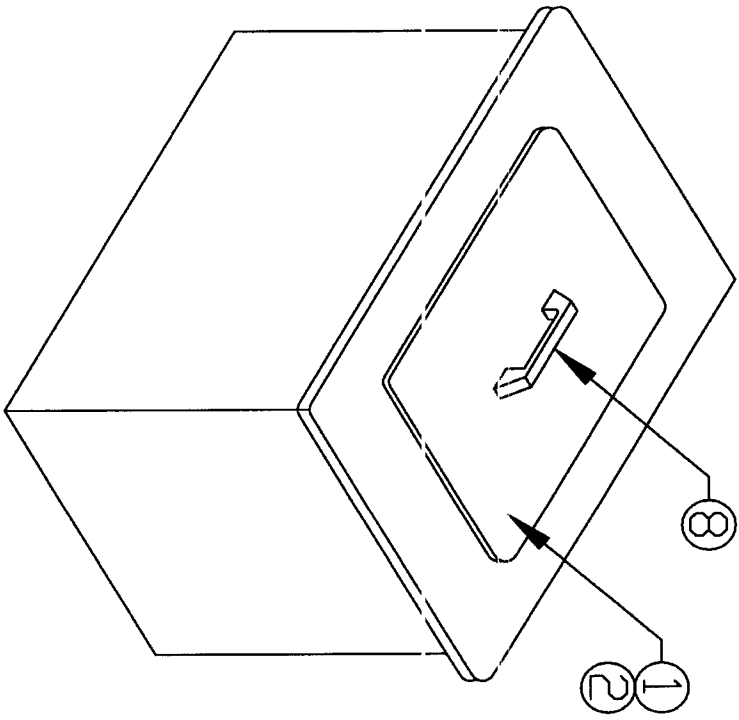

MODEL # 9510-IC  
AND  
MODEL # 9500-IC

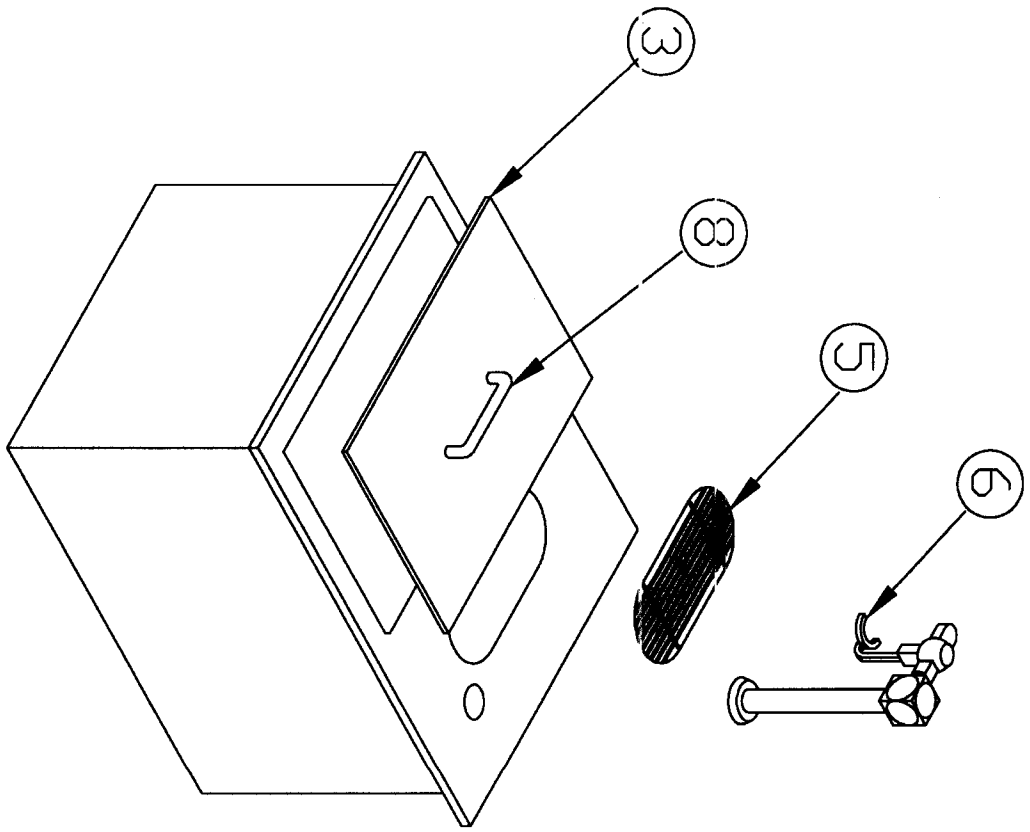

MODEL #

9500  
9505  
9510  
9515

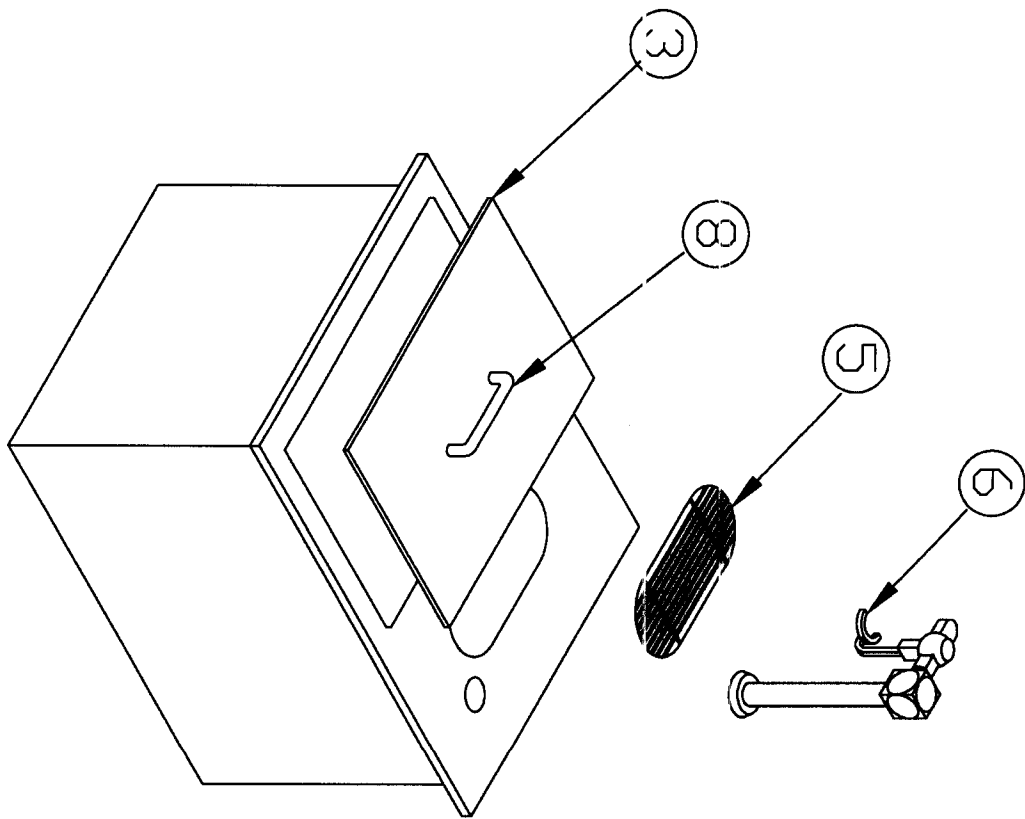

MODEL #

- 9500
- 9505
- 9510
- 9515

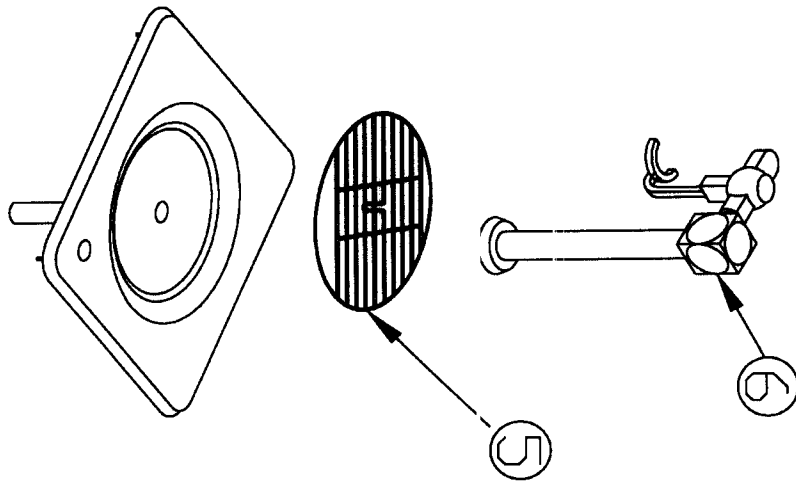

MODEL # 9530

NOTE!  
PART# 7, 8, 9, NOT SHOWN

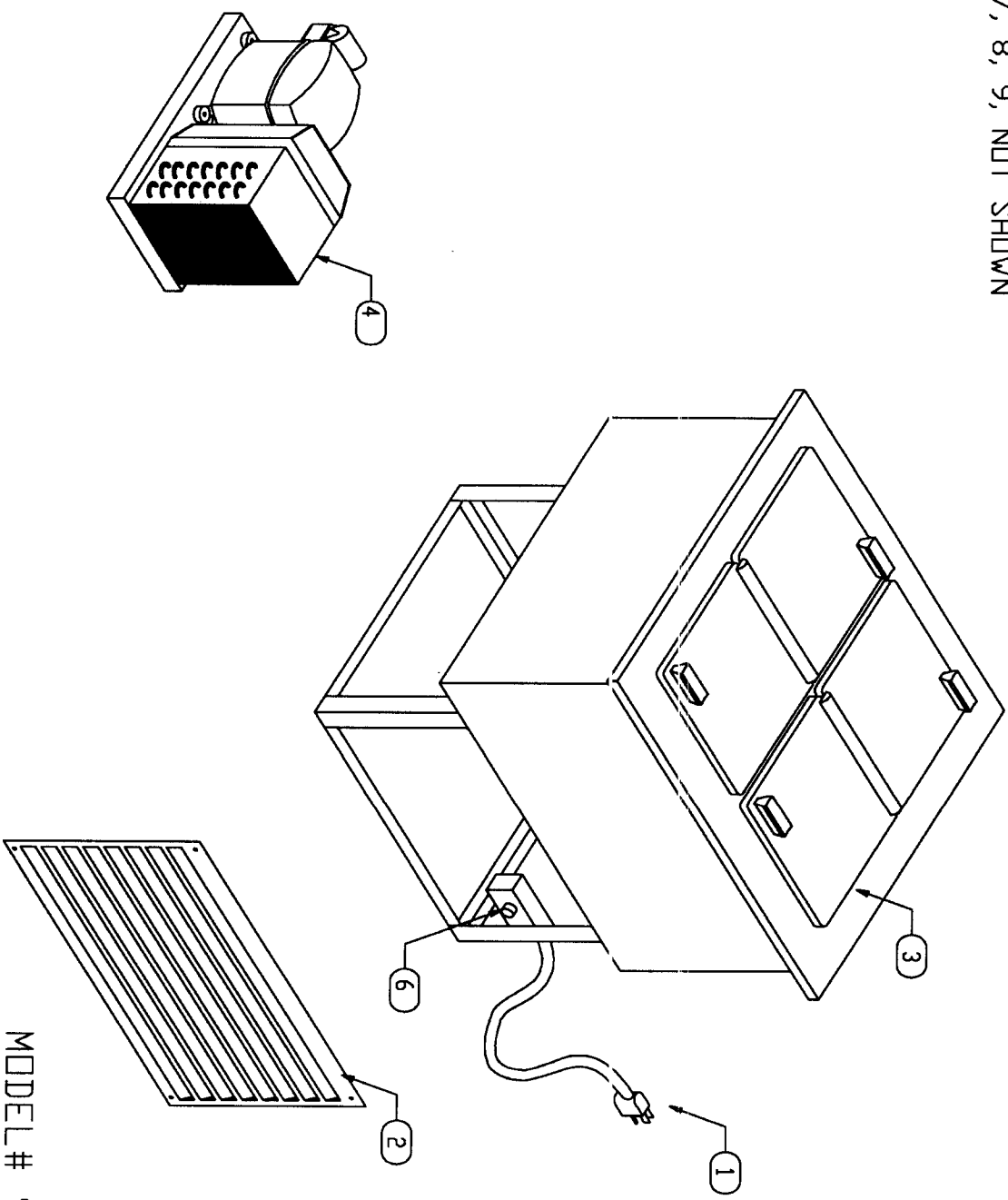

MODEL# 9552  
AND  
MODEL# 9550



NOT SHOWN #5

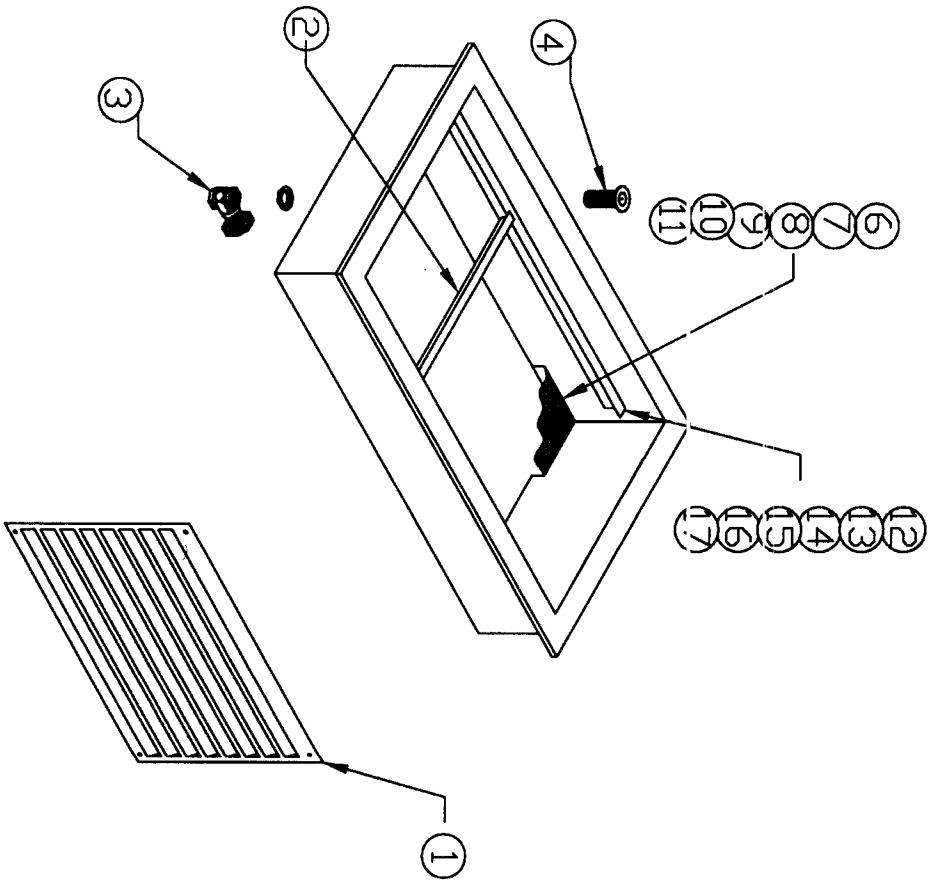

MODEL # 9700

NOT SHOWN #8  
#9  
#10

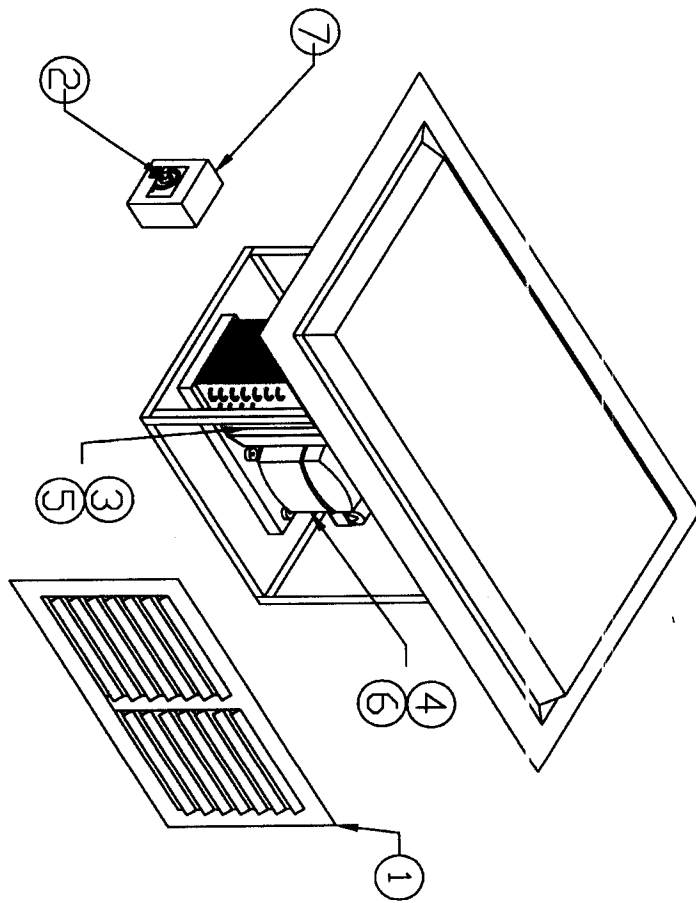

MODEL #9800-SCA

NOT SHOWN #6, 21, 22, 23, 25, 26

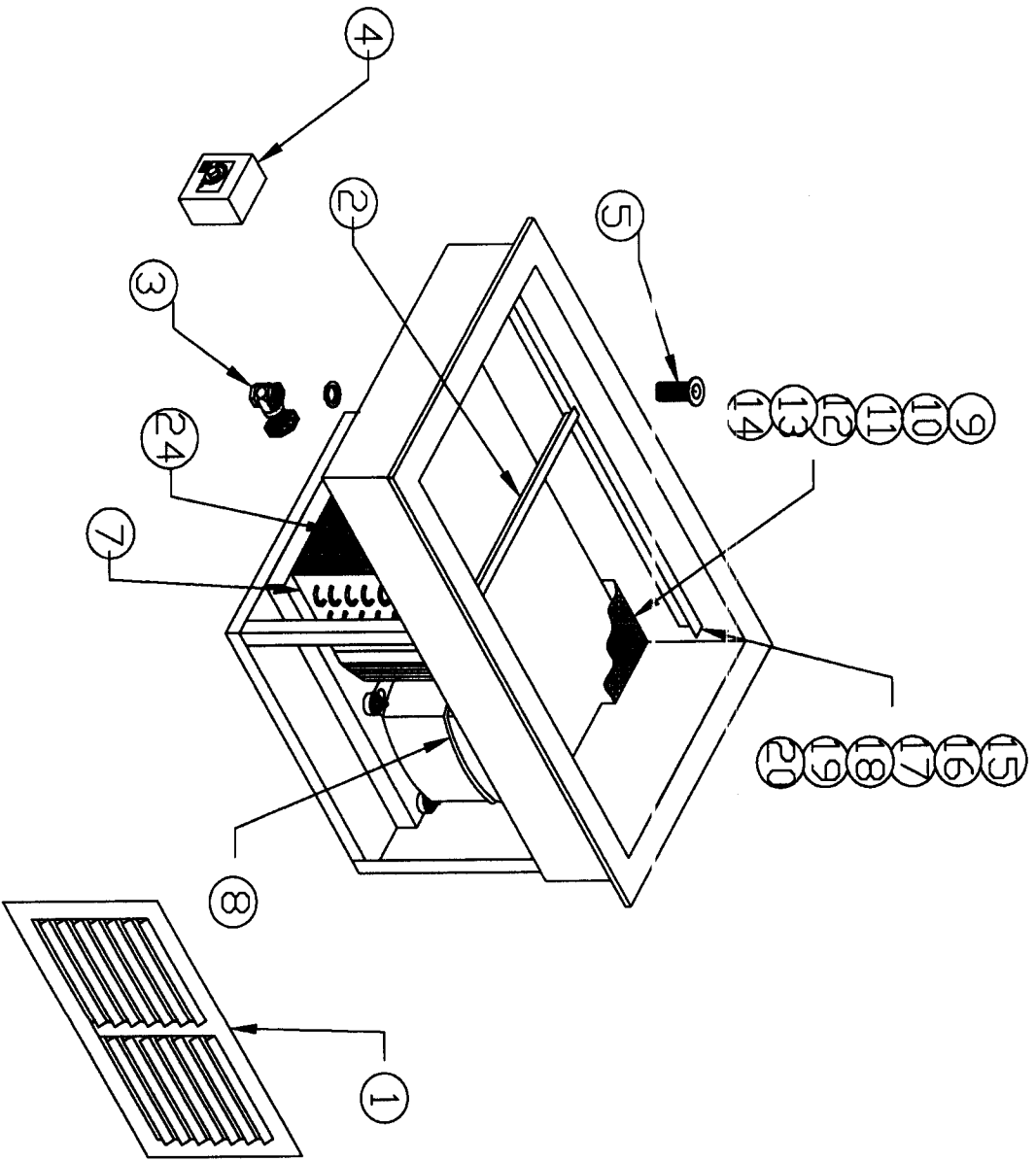

MODEL #9900-SCA

Item	Part Description	Part #	Qty	9500	9500IC	9510	9510IC	9505	9515	9530
1	LID, 9 1/2" X 10 1/2"	RP LID002	1			X				
2	LID, 10 1/2" X 15 1/4"	RP LID003	1				X	X		
3	LID, 9 1/2" X 14"	RP LID004	1	X	X					
4	LID, 7 1/2" X 10 1/2"	RP LID005	1						X	
5	OVAL GRATE	HD DRN200	1	X		X				
6	GLASS FILLER	HD FLR025	1	X		X		X	X	X
7	PITCHER FILLER	HD FLR050	1	X		X		X	X	
8	HANDLE	HD HDL010	1	X	X	X	X	X	X	
9	ROUND GRATE	HD DRN210	1							X
10	DRAIN, 1" BRASS	HD DRN100	1	X	X	X	X	X	X	

**9550 & 9552 6 & 12 GALLON DROP-IN FREEZERS**

ITEM #	PART DESCRIPTION	PART NUMBER	QTY	9550	9552
1	9' CORD SET (NEMA 5-15P) 120V	EL WIR461	1	X	X
2	LOUVER PANEL 14" X 26"	RP LVR426	1	X	X
3	HINGED LID 11.5' X 23.25"	HD LID111	1	X	X
4	CONDENSING UNIT 1/3 HP	RF CON0002	1	X	X
5	COMPRESSOR 1/3 HP AEA2411ZXA	RF CMP031P	1	X	X
6	TEMPERATURE CONTROL LOW TEMP	HD CNT100	1	X	X
7	CAP TUBE W/DRIER .042ID X 120"	RP CAP002	1	X	X
8	FILTER DRIER .042 ID X 1/4"	RF FLT9902	1	X	X
9	ACCUMULATOR	RF ACM005	1	X	X
10	MOTOR, CONDENSER	EL MTR300	1	X	X
11	COIL, CONDENSER 4" X 8" X 10"	RF COI133	1	X	X
12	BLADE, CONDENSER MOTOR 7"	RF FAN007	1	X	X

**9700 SERIES DROP-IN ICE COOLED COLD PANS**

ITEM#	PART DESCRIPTION	PART NUMBER	QTY	18	28	43	57	72	86
1	LOUVER PANEL 18" X 26"	RP LVRC003	1	X	X	X	X	X	X
2	ADAPTER BAR 20"	RP BAR020		3	5	7	9	11	13
3	1" THREADED GATE VALVE	PB VLV1000	1	X	X	X	X	X	X
4	1" BRASS DRAIN	HD DRN100	1	X	X	X	X	X	X
5	DRAIN SCREEN	RP DSN001	1	X	X	X	X	X	X
6	PERFORATED PAN 277MM X 485MM	RP PPN0002	1	X					
7	PERFORATED PAN 626MM X 485MM	RP PPN0003	2		X				
8	PERFORATED PAN 475MM X 485MM	RP PPN0004	2			X			
9	PERFORATED PAN 640MM X 485MM	RP PPN0005	2				X		
10	PERFORATED PAN 823MM X 485MM	RP PPN0006	2					X	
11	PERFORATED PAN 665MM X 485MM	RP PPN0007	2						X
12	ADAPTER BAR SUPPORT BRACKET 339MM	RP BRK013	2	X					
13	ADAPTER BAR SUPPORT BRACKET 667MM	RP BRK027	2		X				
14	ADAPTER BAR SUPPORT BRACKET 493MM	RP BRK019	4			X			
15	ADAPTER BAR SUPPORT BRACKET 657MM	RP BRK026	4				X		
16	ADAPTER BAR SUPPORT BRACKET 823MM	RP BRK032	4					X	
17	ADAPTER BAR SUPPORT BRACKET 655MM	RP BRK025	4						X

**9800 SERIES DROP-IN ICE COOLED COLD PANS**

ITEM #	PART DESCRIPTION	PART NUMBER	QTY	28	43	57	72	86
1	LOUVER PANEL 18" X 26"	RP LVR0003	1	X	X	X	X	X
2	TOGGLE SWITCH	EL SW T120	1	X	X	X	X	X
3	CONDENSING UNIT AEA2413ZAEC	RF CCN0003	1		X	X	X	X
4	COMPRESSOR 1/3 HP	RF CMP031P	1		X	X	X	X
5	CONDENSING UNIT AEA2410YXAXL	RF CCN0001	1	X				
6	COMPRESSOR 1/4 HP	RFCMP495	1	X				
7	TEMPERATURE CONTROL LOW TEMP	HD CNT9902	1	X	X	X	X	X
8	FILTER DRIER	RF FLT134A	1	X	X	X	X	X
9	CONDENSER MOTOR	EL MTR300	1	X	X	X	X	X
10	CONDENSER FAN BLADE	RF FAN007	1	X	X	X	X	X

ITEM#	PART DESCRIPTION	PART NUMBER	QTY	18	28	43	57	72	86
1	LOUVER PANEL 18" X 26"	RP LVR0003	1	X	X	X	X	X	X
2	ADAPTER BAR 20"	RP BAR020		3	5	7	9	11	13
3	1" THREADED GATE VALVE	PB VLV1000	1	X	X	X	X	X	X
4	TEMPERATURE CONTROL LOW TEMP	HD CNT9902	1	X	X	X	X	X	X
5	1" BRASS DRAIN	HD DRN100	1	X	X	X	X	X	X
6	DRAIN SCREEN	RP DSN001	1	X	X	X	X	X	X
7	CONDENSING UNIT AEA2410YXAXL	RF CON0201	1	X	X	X	X	X	X
8	COMPRESSOR, 1/4 HP	RF CMP495	1	X	X	X	X	X	X
9	PERFORATED PAN 277MM X 485MM	RP PP N0002	1	X					
10	PERFORATED PAN 626MM X 485MM	RP PP N0003	2		X				
11	PERFORATED PAN 475MM X 485MM	RP PP N0004	2			X			
12	PERFORATED PAN 640MM X 485MM	RP PP N0005	2				X		
13	PERFORATED PAN 823MM X 485MM	RP PP N0006	2					X	
14	PERFORATED PAN 665MM X 485MM	RP PP N0007	2						X
15	ADAPTER BAR SUPPORT BRACKET 339MM	RP BRK013	2	X					
16	ADAPTER BAR SUPPORT BRACKET 667MM	RP BRK027	2		X				
17	ADAPTER BAR SUPPORT BRACKET 493MM	RP BRK019	4			X			
18	ADAPTER BAR SUPPORT BRACKET 657MM	RP BRK026	4				X		
19	ADAPTER BAR SUPPORT BRACKET 823MM	RP BRK032	4					X	
20	ADAPTER BAR SUPPORT BRACKET 655MM	RP BRK025	4						X
21	FILTER DRIER 1/4' X .042ID	RF FLT9902	1	X	X	X	X	X	X
22	CAP TUBE W/DRIER .036 ID X 96" LONG	RP CAP014	1	X	X	X	X	X	X
23	HOUSING, COMP AIRFLOW DROPINS	RP HSG0004	1	X	X	X	X	X	X



**9900 SERIES DROP-IN MECHANICAL COLD PANS**

ITEM#	PART DESCRIPTION	PART NUMBER	QTY	18	28	43	57	72	86
1	LOUVER PANEL 18" X 26"	RP LVR0003	1	X	X	X	X	X	X
2	ADAPTER BAR 20"	RP BAR020		3	5	7	9	11	13
3	1" THREADED GATE VALVE	PB VLV1000	1	X	X	X	X	X	X
4	TEMPERATURE CONTROL LOW TEMP	HD CNT9902	1	X	X	X	X	X	X
5	1" BRASS DRAIN	HD DRN100	1	X	X	X	X	X	X
6	DRAIN SCREEN	RP DSN001	1	X	X	X	X	X	X
7	CONDENSING UNIT AEA2410YXAXL	RF CON0201	1	X	X	X	X	X	X
8	COMPRESSOR, 1/4 HP	RF CMP0095	1	X	X	X	X	X	X
9	PERFORATED PAN 277MM X 485MM	RP PPNC002	1	X					
10	PERFORATED PAN 626MM X 485MM	RP PPNC003	2		X				
11	PERFORATED PAN 475MM X 485MM	RP PPNC004	2			X			
12	PERFORATED PAN 640MM X 485MM	RP PPNC005	2				X		
13	PERFORATED PAN 823MM X 485MM	RP PPNC006	2					X	
14	PERFORATED PAN 665MM X 485MM	RP PPNC007	2						X
15	ADAPTER BAR SUPPORT BRACKET 339MM	RP BRK0013	2	X					
16	ADAPTER BAR SUPPORT BRACKET 667MM	RP BRK0027	2		X				
17	ADAPTER BAR SUPPORT BRACKET 493MM	RP BRK0019	4			X			
18	ADAPTER BAR SUPPORT BRACKET 657MM	RP BRK0026	4				X		
19	ADAPTER BAR SUPPORT BRACKET 823MM	RP BRK0032	4					X	
20	ADAPTER BAR SUPPORT BRACKET 655MM	RP BRK0025	4						X
21	FILTER DRIER 1/4' X .042ID	RF FLT9902	1	X	X	X	X	X	X
22	CAP TUBE W/DRIER .036 ID X 144" LONG	RP CAP0023	1	X	X	X	X	X	X
23	HOUSING, COMP AIRFLOW DROPINS	RP HSG0004	1	X	X	X	X	X	X