

## OPERATORS MANUAL

This manual provides  
Installation & Operating instructions for

# ***PIZZA HUT ITALIAN BISTRO PASTA FINISHING TABLES***

For Models:

PH48SPA-L-R, PH48SPA-R-L

PH66SPA-L-R, PH66SPA-R-L



### **NOTIFY CARRIER OF DAMAGE AT ONCE.**

It is the responsibility of the consignee to inspect the container upon receipt of same and to determine the possibility of any damage, including concealed damage. Avtec suggests that if you are suspicious of damage to make a notation on the delivery receipt. It will be the responsibility of the consignee to file a claim with the carrier. We recommend that you do so at once.

Manufacture Service/Questions 888-994-7636.



1055 Mendell Davis Drive  
Jackson, MS 39272  
888-994-7636, fax 888-864-7636  
unifiedbrands.net



## Table of Contents

page 2.....	Congratulations
page 3.....	Parts & Service Hotline
page 3.....	Serial Number Location
page 4-7.....	Randell Limited Warranty
page 8.....	Unit Specifications
page 9-10.....	Unit Operation
page 11-12.....	Preventive Maintenance
page 13.....	Electrical Diagram
page 14.....	Troubleshooting
page 15-19.....	Replacement Parts

Congratulations on your recent purchase of Randell food service equipment, and welcome to the growing family of satisfied Randell customers.

Our reputation for superior products is the result of consistent quality craftsmanship. From the earliest stages of product design to successive steps in fabrication and assembly, rigid standards of excellence are maintained by our staff of designers, engineers, and skilled employees.

Only the finest heavy-duty materials and parts are used in the production of Randell brand equipment. This means that each unit, given proper maintenance will provide years of trouble free service to its owner.



**In addition, all Randell food service equipment is backed by some of the best warranties in the food service industry and by our professional staff of service technicians.**

**Retain this manual for future reference.**

**NOTICE:** Due to a continuous program of product improvement, Randell Manufacturing reserves the right to make changes in design and specifications without prior notice.

**NOTICE:** Please read the entire manual carefully before installation. If certain recommended procedures are not followed, warranty claims will be denied.

<p><b>MODEL NUMBER</b> _____</p> <p><b>SERIAL NUMBER</b> _____</p> <p><b>INSTALLATION DATE</b> _____</p>
--

The serial number is located in the mechanical housing.

**800-621-8560**

**Randell Manufacturing Service  
and Parts Hotline**

## Warranty Policies

Congratulations on your purchase of a Randell Manufactured piece of equipment. Randell believes strongly in the products it builds and backs them with the best warranty in the industry. Standard with every unit comes the peace of mind that this unit has been thoroughly engineered, properly tested and manufactured to excruciating tolerances, by a manufacturer with over 25 years of industry presence. On top of that front end commitment, Randell has a dedicated staff of certified technicians that monitor our own technical service hotline at **1-800-621-8560** to assist you with any questions or concerns that may arise after delivery of your new Randell equipment.

### **PARTS WARRANTY**

1. One year parts replacement of any and all parts that are found defective in material or workmanship. Randell warrants all component parts of manufactured new equipment to be free of defects in material or workmanship, and that the equipment meets or exceeds reasonable industry standards of performance for a period of one year from the date of shipment from any Randell factory, assembly plant or warehouse facility.

**NOTE: warranties are effective from date of shipment, with a thirty day window to allow for shipment, installation and set-up. In the event equipment was shipped to a site other than the final installation site, Randell will warranty for a period of three months following installation, with proof of starting date, up to a maximum of eighteen months from the date of purchase.**

2. Free ground freight of customer specified location for all in warranty parts within continental U.S. Component part warranty does not cover glass breakage or gasket replacement. Randell covers all shipping cost related to component part warranty sent at regular ground rates (UPS, USPS). **Freight or postage incurred for any express or specialty methods of shipping are the responsibility of the customer.**

### **LABOR COVERAGE**

In the unlikely event a Randell manufactured unit fails due to defects in materials or workmanship within the first ninety days, Randell agrees to pay reasonable labor incurred. During the first ninety days, work authorizations are not required for in warranty repairs. However, repair times are limited to certain flex rate schedules and hours will be deducted from service invoices if they exceed allowed times without prior approval and a work authorization number. Warranties are effective from date of shipment, with a thirty day window to allow for shipment, installation and setup. Where equipment is shipped to any site other than final installation, Randell will honor the labor

warranty for a period of ninety days following installation with proof of starting date, up to a maximum of nine months from date of purchase. Travel time is limited to one hour each direction or two hours per invoice. **Any travel time exceeding two hours will be the responsibility of the customer.**

**Temperature adjustments are not covered under warranty**, due to the wide range of ambient conditions.

To request a warranty approval number, call our Field Service Department at: 1-800-621-8560

#### **WHEN OPTIONAL 5 YEAR COMPRESSOR WARRANTY APPLIES**

1. Provide reimbursement to servicing company for the cost of locally obtained replacement compressor in exchange for the return of the defective compressor sent back freight prepaid. Note: Randell Manufacturing does limit amount of reimbursement allowed and does require bill from local supply house where compressor was obtained (customer should not pay servicing agent up front for compressor).
2. Provide repair at the manufacturing facility by requiring that the defective unit be sent back to Randell freight prepaid. Perform repair at the expense of Randell and ship the item back to the customer freight collect.
3. Furnish complete condensing unit freight collect in exchange for the return of the defective compressor sent back freight prepaid. (Decisions on whether or not to send complete condensing units will be made by Randell's in-house service technician).

#### **WHEN OPTIONAL LABOR EXTENSION POLICY APPLIES**

Randell Manufacturing will provide reimbursement of labor invoiced to any customer that has an optional labor extension of our standard warranty. (Reasonable geographic and industry rates do apply) Randell offers both 1 and 2 year extensions. Labor extensions begin at the end of our standard warranty and extend out 9 months to 1 calendar year or 21 months to 2 calendar years from date of purchase. Please contact Randell Manufacturing's technical service hotline at 1-800-621-8560 for details and warranty authorization numbers.

#### **WHEN EXPORT WARRANTIES APPLY**

1. Randell Manufacturing covers all non-electrical components under the same guidelines as our standard domestic policy.
2. All electrical components operated on 60 cycle power are covered under our standard domestic policy.
3. All electrical components operated on 50 cycle power are covered for 90 days from shipment only.
4. Extended warranty options are not available from the factory.

#### **ITEMS NOT COVERED UNDER WARRANTY**

1. Maintenance type of repairs such as condenser cleaning, temperature adjustments, clogged drains and unit leveling.
2. Randell does not cover gaskets under warranty. Gaskets are a maintenance type component that are subject to daily wear and tear and are the responsibility of the owner of the equipment. Because of

the unlimited number of customer related circumstances that can cause gasket failure all gasket replacement issues are considered non-warranty. Randell recommends thorough cleaning of gaskets on a weekly basis with a mild dish soap and warm water. With proper care Randell gaskets can last up to two years, at which time we recommend replacement of all gaskets on the equipment for the best possible performance.

**NOTICE: FOOD LOSS IS NOT COVERED UNDER WARRANTY**

3. Repairs caused by abuse such as broken glass, freight damage, or scratches and dents.
4. Electrical component failure due to water damage from cleaning procedures.

**QUOTATIONS**

Verbal quotations are provided for customer convenience only and are considered invalid in the absence of a written quotation. Written quotations from Randell are valid for 30 days from quote date unless otherwise specified. Randell assumes no liability for dealer quotations to end-users.

**SPECIFICATION & PRODUCT DESIGN**

Due to continued product improvement, specification and product design may change without notice. Such revisions do not entitle the buyer to additions. Changes or replacements for previously purchased equipment.

**SANITATION REQUIREMENTS**

Certain areas require specific annotation requirements other than N.S.F. & U.L. standards. Randell must be advised of these specifications before fabrication of equipment. In these special circumstances, a revised quotation may be required to cover additional costs. Failure to notify Randell before fabrication holds the dealer accountable for all additional charges.

**CANCELLATIONS**

Orders canceled prior to production scheduling entered into engineering/production and cancelled are subject to a cancellation charge (contact factory for details).

**STORAGE CHARGES**

Randell makes every effort to consistently meet our customer's shipment expectations. If after the equipment has been fabricated, the customer requests delay in shipment, and warehousing is required:

1. Equipment held for shipment at purchasers request for a period of 30 days beyond original delivery date specified will be invoiced and become immediately payable.
2. Equipment held beyond 30 days after the original delivery date specified will also include storage charges.

**SHIPPING & DELIVERY**

Randell will attempt to comply with any shipping, routing or carrier request designated by dealer, but reserves the right to ship merchandise via any responsible carrier at the time equipment is ready for shipment. Randell will



not be held responsible for any carrier rate differences; rate differences are entirely between the carrier and purchaser. Point of shipping shall be determined by Randell (Weidman, MI/Tucson, AZ). At dealer's request, Randell will endeavor whenever practical to meet dealer's request. Freight charges to be collect unless otherwise noted.

### **DAMAGES**

All crating conforms to general motor carrier specifications. To avoid concealed damage, we recommend inspection of every carton upon receipt. In the event the item shows rough handling or visible damage to minimize liability, a full inspection is necessary upon arrival. Appearance of damage will require removing the crate in the presence of the driver. **A notation must be placed on the freight bill and signed for by the truck driver at the time of delivery.** Any and all freight damage that occurs to a Randell piece of equipment as a result of carrier handling is not considered under warranty, and is not covered under warranty guidelines. Any freight damage incurred during shipping needs to have a freight claim filed by the receiver with the shipping carrier. Consignee is responsible for filing of freight claims when a clear delivery receipt is signed. Claims for damages must be filed immediately (within 10 days) by the consignee with the freight carrier and all cartons and merchandise must be retained for inspection.

### **RETURNED GOODS**

Authorization for return must first be obtained from Randell before returning any merchandise. Any returned goods shipment lacking the return authorization number will be refused, all additional freight costs to be borne by the returning party. Returned equipment must be shipped in original carton, freight prepaid and received in good conditions. Any returned merchandise is subject to a minimum handling charge (consult factory for rate).

### **INSTALLATION**

Equipment installation is the responsibility of the dealer and/or their customer. Randell requires all equipment to be professionally installed.

### **PENALTY CLAUSES**

Dealer penalty clauses, on their purchase order or contractually agreed to between the dealer and their clients are not binding on Randell. Randell does not accept orders subject to penalty clauses. This agreement supersedes any such clauses in dealer purchase orders.

### **EXPORT POLICY**

All quotations for export sales will be handled by Dorian Drake International ([www.doriandrake.com](http://www.doriandrake.com)), Randell's export management organization.

#### **\*FOOTNOTES IN REFERENCE TO PARAGRAPHS ABOVE**

1. Herein called Randell.
2. NET means list price less discount, warranty, labor policy, freight, Randell delivery and other miscellaneous charges.

CASH DISCOUNTS WILL BE CALCULATED ON NET ONLY.

## Unit Specifications



PH66SPA-L-R

shown

Model	L	D	H	Work Hgt.	Cold Rail	Drawers	Doors	H.P.	Volts	Amps	NEMA	Ship Wt.
PH48SPA-L-R	48"	40.43"	68.46"	36"	44"x20"	(3)27"ext.	N/A	1/3	115	10	5-15P	525
PH48SPA-R-L	48"	40.43"	68.46"	36"	44"x20"	(3)27"ext.	N/A	1/3	115	10	5-15P	525
PH66SPA-L-R	66"	40.43"	68.46"	36"	62"x20"	(3)27"ext.	(1)27"	1/2	115	12	5-15P	720
PH66SPA-R-L	66"	40.43"	68.46"	36"	62"x20"	(3)27"ext.	(1)27"	1/2	115	12	5-15P	720

The PH48SPA-L-R and the PH66SPA-L-R are set up for left to right operation and have the mechanical housing located on the right.

The PH48SPA-R-L and the PH66SPA-R-L are set up for right to left operation and have the mechanical housing located on the left.

# Unit Operation

## MORNING STARTUP

1. Unit cleaning may be performed at this time.
2. Turn on unit.
3. Allow 45 minutes to one hour for your unit to cool down before loading product.
4. Load the product and proceed with food preparation.

## EVENING SHUT DOWN

1. Remove product from unit at the end of the day's preparation.
2. Turn off unit.
3. Unit cleaning may be performed at this time if the frost has melted off the surface.

Randell has attempted to preset the cold controls to ensure that your unit runs at an optimum temperature, but due to varying ambient conditions, including elevation, food product as well as type of operation, you may need to alter this temperature.

Your pasta finishing table was equipped with a temperature adjustment control for the refrigerated rail located in the mechanical housing (Figure 1, item A).

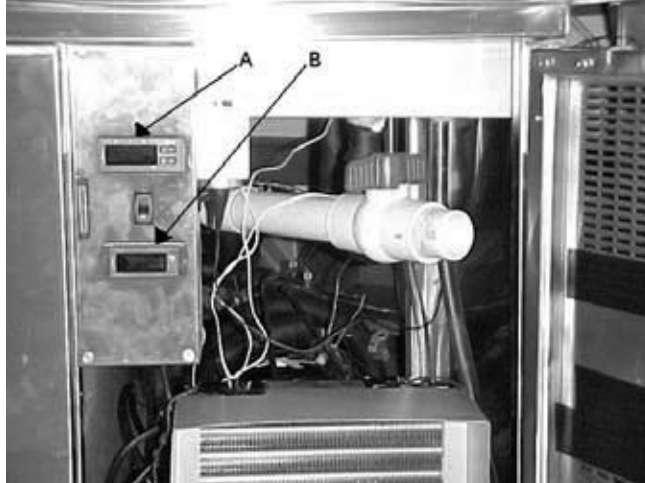

**Figure 1** illustrates the inside of the mechanical housing behind the louvered panel. Item **A** is pointing out the temperature control for refrigerated rail. Item **B** is pointing out the digital thermometer for the refrigerated base.

### To raise temperature in the refrigerated rail:

- A. Push and hold the “set” button until 34 appears then release the “set” button. 34 is the current set point temperature.
- B. Push and release the up arrow 2 times until 36 is displayed. Push and release the “set” button one time. The new set point, 36, will flash 3 times and then will be locked in.

**To lower temperature in the refrigerated rail:**

- A. Push and hold the “set” button until 34 appears and then release the “set” button. 34 is the current set point temperature.
- B. Push and release the up arrow 2 times until 32 is displayed. Push and release the “set” button one time. The new set point, 32, will flash 3 times and then will be locked in.

**NOTE: It is recommended to only make changes of 2 degree increments at a time. Allow for the unit to operate 24 hours between adjustments. If the 2 degree adjustment is not enough another adjustment can be made. The maximum highest setting is 38 degrees and the minimum lowest setting is 28 degrees. If the settings need to go above or below this point there may be other contributing factors as to the cause of the temperature variances, please contact the factory at 1-800-621-8560.**

The base temperature can also be adjusted by the temperature control dial located on the front of the refrigeration coil inside the refrigerated base. The thermometer for the base temperature is located in the mechanical housing (Figure 1, item b).

**To adjust temperature in the refrigerated base:**

- A. Locate evaporator coil inside cooler between the mechanical housing and the set of refrigerated drawers.
- B. Thermostat is located at top front of evaporator coil. There are numbers to indicate settings.
- C. Turn clockwise for colder setting (higher number).
- D. Turn counterclockwise for warmer setting (lower number).

**NOTE: It is not recommended to turn the dial above 8 or below 1 on the temperature control. If the adjustments still do not result in proper temperature please contact the factory at 1-800-621-8560.**

## Preventive Maintenance

Randell strongly suggests a preventive maintenance program which would include the following **Monthly** procedures:

1. Cleaning of all condenser coils. Condenser coils are a critical component in the life of the compressor and must remain clean to assure proper air flow and heat transfer. Failure to maintain this heat transfer will affect unit performance and eventually destroy the compressor. Clean the condenser coils with coil cleaner and/or a vacuum, cleaner and brush.

**NOTE: Brush coil in direction of fins, normally vertically as to not damage or restrict air from passing through condenser.**

2. Clean fan blade on the condensing unit.
3. Clean and disinfect drains with a solution of warm water and bleach.
4. Clean and disinfect drain lines and evaporator pan with a solution of warm water and bleach.
5. Clean all gaskets on a weekly if not daily basis with a solution of warm water and a mild detergent to extend gasket life.

**NOTE: DO NOT USE SHARP UTENSILS.**

**RECOMMENDED CLEANERS FOR YOUR STAINLESS STEEL INCLUDE THE FOLLOWING:**

JOB	CLEANING AGENT	COMMENTS
Routine cleaning	Soap, ammonia, detergent Medallion	Apply with a sponge or cloth
Fingerprints and smears	Arcal 20, Lac-O-Nu, Ecoshine	Provides a barrier film
Stubborn stains and discoloration	Cameo, Talc, Zud, First Impression	Rub in the direction of the polish lines
Greasy and fatty acids, blood, burnt-on foods	Easy-Off, Degrease It, Oven Aid	Excellent removal on all finishes
Grease and Oil	Any good commercial detergent	Apply with a sponge or cloth
Restoration/Preservation	Benefit, Super Sheen	Good idea monthly

Reference: Nickel Development Institute, Diversey Lever, Savin, Ecolab, NAFEM.

**NOTE: Do not use steel pads, wire brushes, scrapers, or chloride cleaners to clean your stainless steel. CAUTION: DO NOT USE ABRASIVE CLEANING SOLVENTS, AND NEVER USE HYDROCHLORIC ACID (MURIATIC ACID) ON STAINLESS STEEL.**

**NOTE:** Do not pressure wash equipment as damage to electrical components may result.

## Preventive Maintenance (cont.)

To remove and re-install drawer tracks, please refer to Figure 2 below for proper installation instructions.

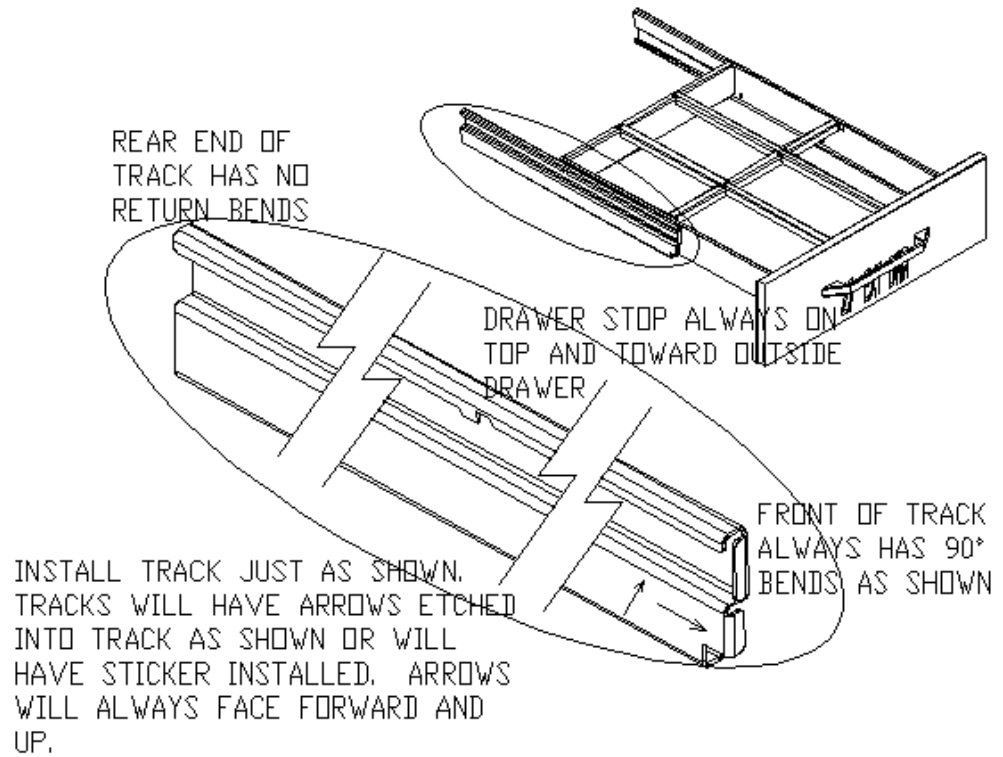

**Figure 2**

Proper maintenance of equipment is the ultimate necessity in preventing costly repairs. By evaluating each unit on a regular schedule, you can often catch and repair minor problems before they completely disable the unit and become burdensome on your entire operation.

**For more information on preventive maintenance, consult your local service company or CFESA member.** Most repair companies offer this service at very reasonable rates to allow you the time you need to run your business along with the peace of mind that all your equipment will last throughout its expected life. These services often offer guarantees as well as the flexibility in scheduling or maintenance for your convenience.

Randell believes strongly in the products it manufactures and backs those products with one of the best warranties in the industry. We believe with the proper

maintenance and use, you will realize a profitable return on your investment and years of satisfied service.

# Electrical Diagram

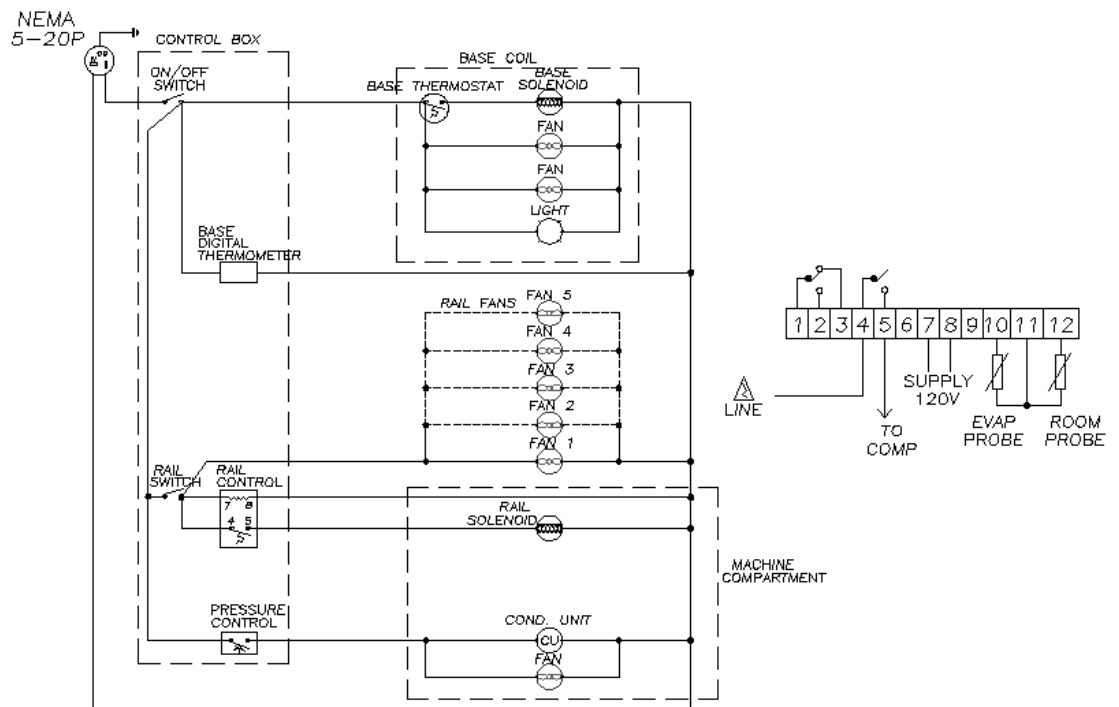



## Trouble Shooting Guide

SYMPTOM	POSSIBLE CAUSE	PROCEDURE
Unit doesn't run	<ol style="list-style-type: none"> <li>1. No power to unit</li> <li>2. Temperature control turned off</li> <li>3. Temperature control faulty</li> <li>4. Compressor overheated</li> <li>5. Condenser fan faulty</li> <li>6. Overload protector faulty</li> <li>7. Compressor relay faulty</li> <li>8. Compressor faulty</li> </ol>	<ol style="list-style-type: none"> <li>1. Plug in unit</li> <li>2. Check temperature control</li> <li>3. Test temperature control</li> <li>4. Clean condenser coil</li> <li>5. Service condenser fan</li> <li>6. Test overload</li> <li>7. Test relay</li> <li>8. Call for service at <b>800-621-8561</b></li> </ol>
Unit short cycles	<ol style="list-style-type: none"> <li>1. Condenser coil dirty</li> <li>2. Condenser fan faulty</li> <li>3. Compressor faulty</li> <li>4. Overload repeatedly tripping</li> </ol>	<ol style="list-style-type: none"> <li>1. Clean coil</li> <li>2. Service fan and motor.</li> <li>3. Call for service at <b>800-621-8561</b></li> <li>4. Check outlet voltage</li> </ol>
Unit runs constantly	<ol style="list-style-type: none"> <li>1. Condenser coil dirty</li> <li>2. Condenser fan faulty</li> </ol>	<ol style="list-style-type: none"> <li>1. Clean coil</li> <li>2. Service condenser motor</li> </ol>
Unit not cold enough	<ol style="list-style-type: none"> <li>1. Temperature control set too high</li> <li>2. Temperature control faulty</li> <li>3. Condenser coil dirty</li> <li>4. Refrigerant leaking or contaminated</li> </ol>	<ol style="list-style-type: none"> <li>1. Adjust control to lower setting</li> <li>2. Test control</li> <li>3. Clean coil</li> <li>4. Call for service at <b>800-621-8561</b></li> </ol>
Unit too cold	<ol style="list-style-type: none"> <li>1. Temperature control set too low</li> <li>2. Temperature control faulty</li> </ol>	<ol style="list-style-type: none"> <li>1. Adjust control to raise setting</li> <li>2. Test control</li> </ol>
Unit noisy	<ol style="list-style-type: none"> <li>1. Compressor mountings loose or hardened.</li> <li>2. Condenser fan damaged or hitting fan shroud</li> </ol>	<ol style="list-style-type: none"> <li>1. Tighten or replace compressor mountings</li> <li>2. Inspect condenser fan</li> </ol>

# Replacement Parts List

# Pasta Finishing Tables PH48SPA-L-R, PH48SPA-R-L PH66SPA-L-R, PH66SPA-R-L

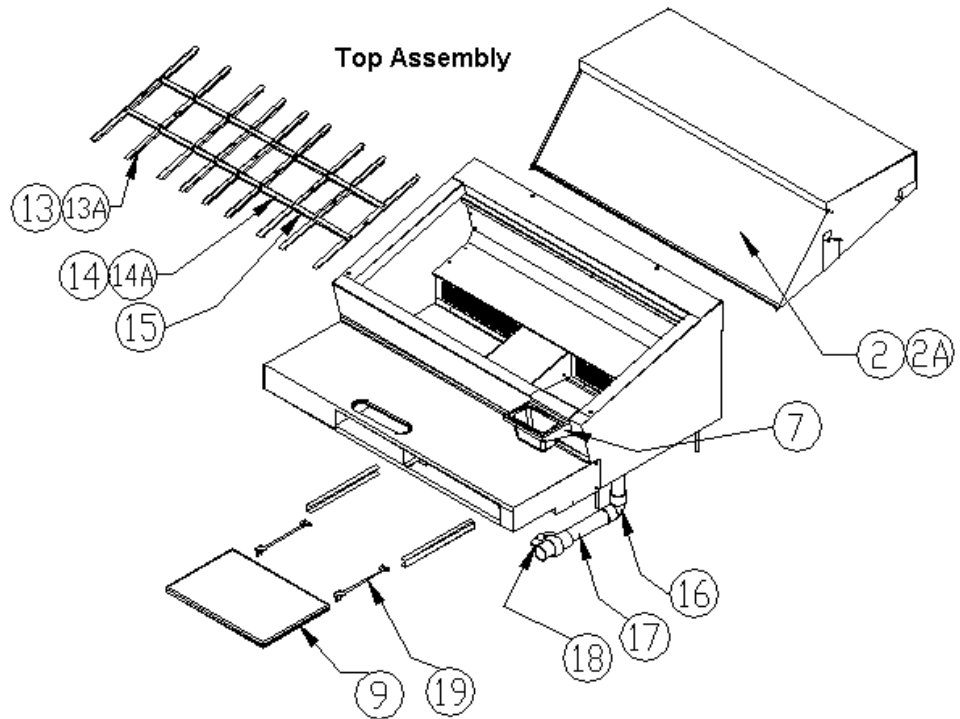
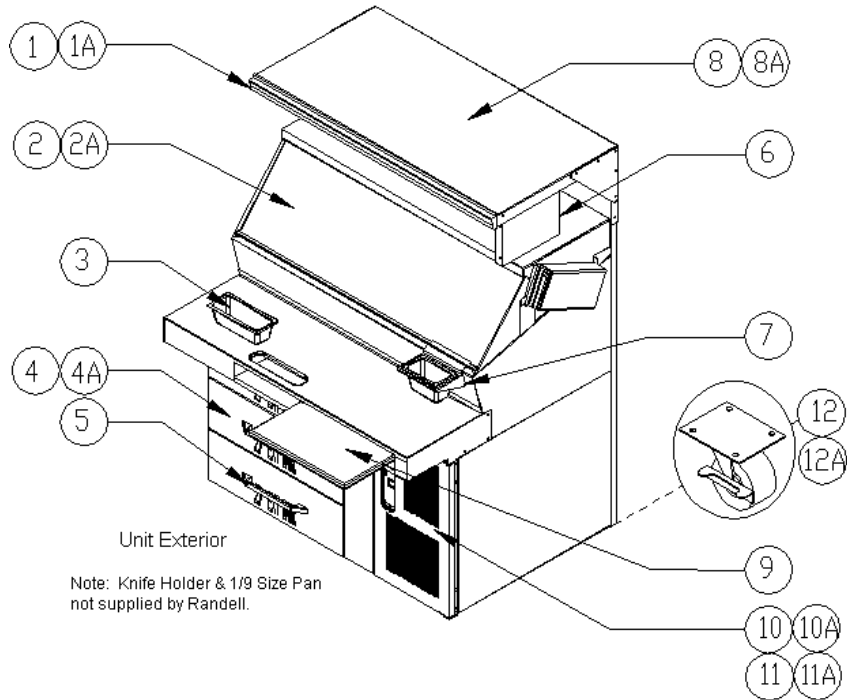

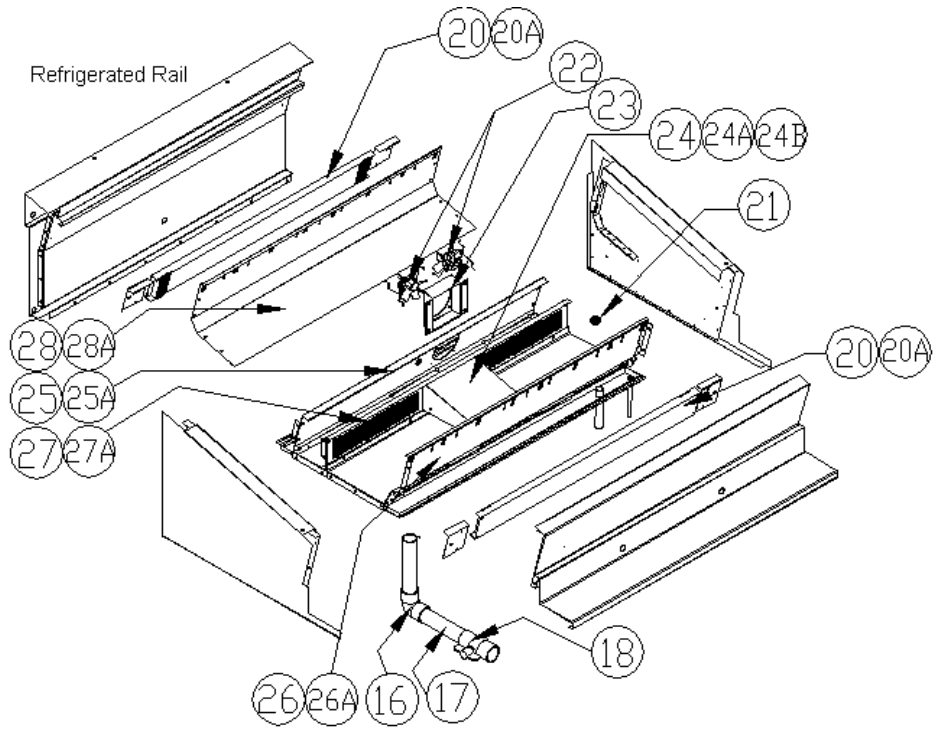

Refrigerated Pan Rail  
PH66SPA-L-R shown

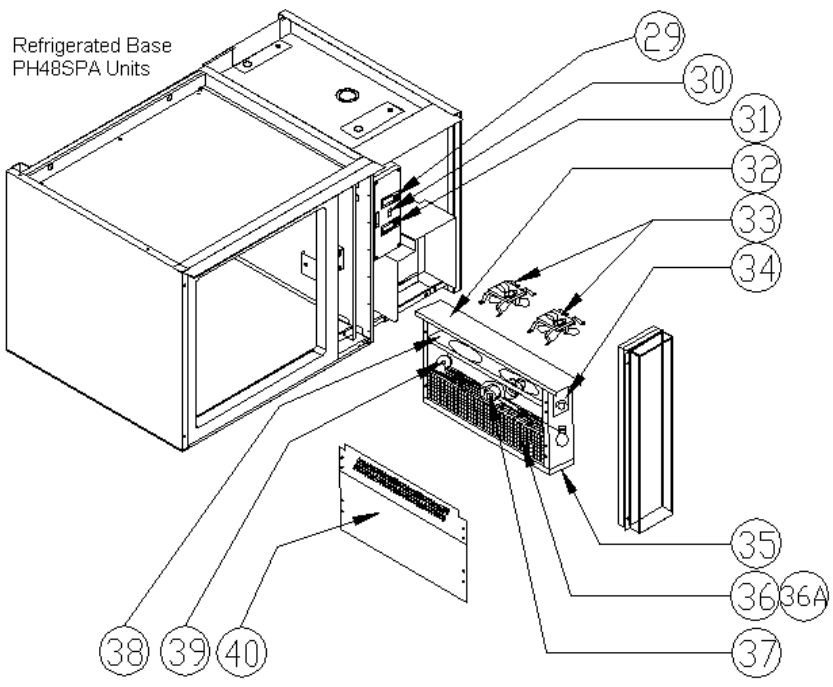

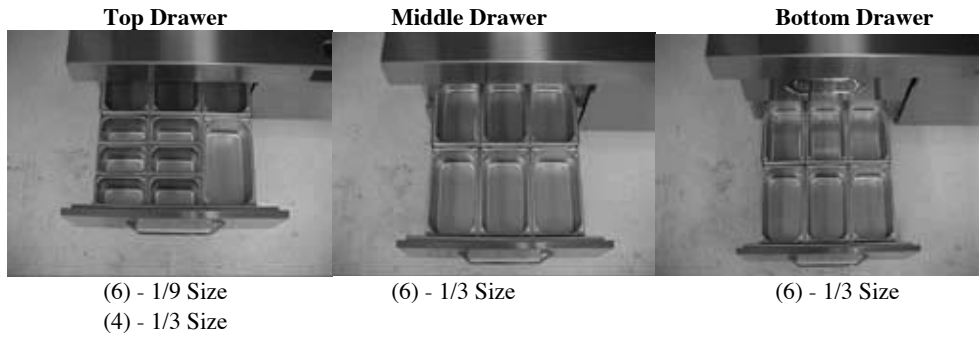
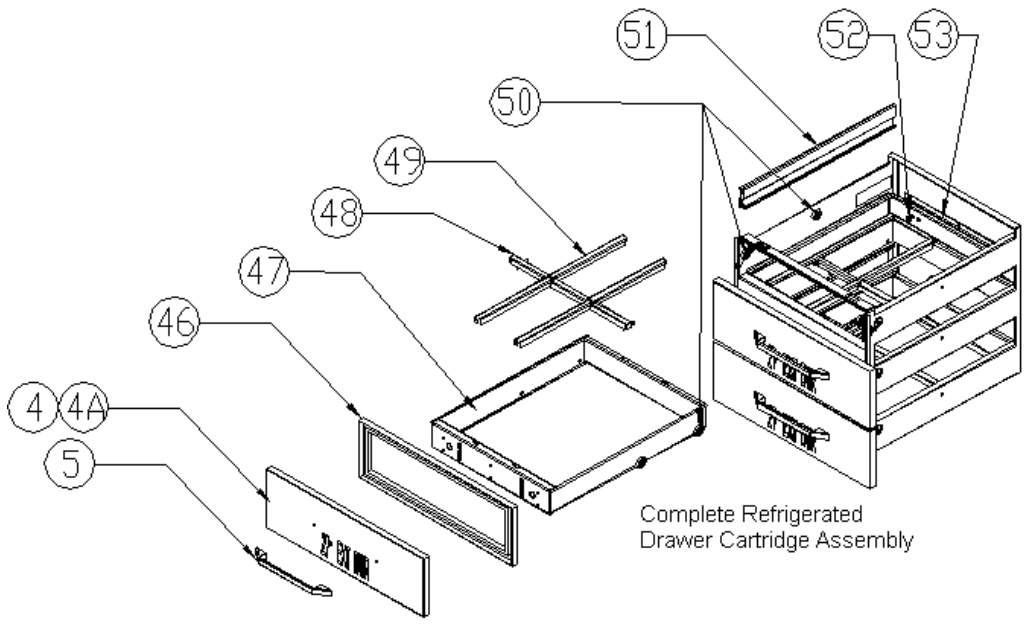
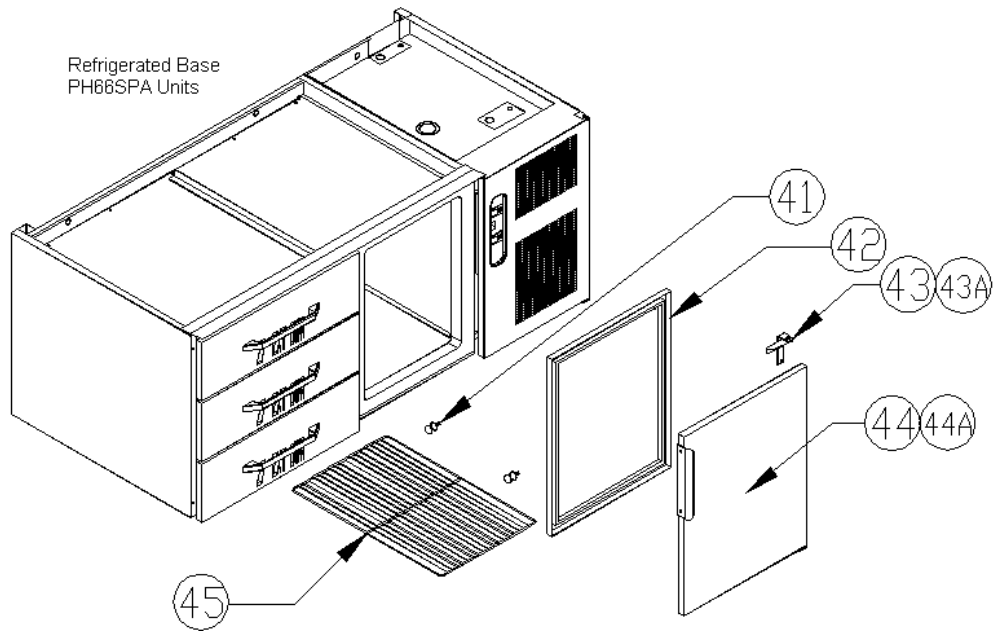

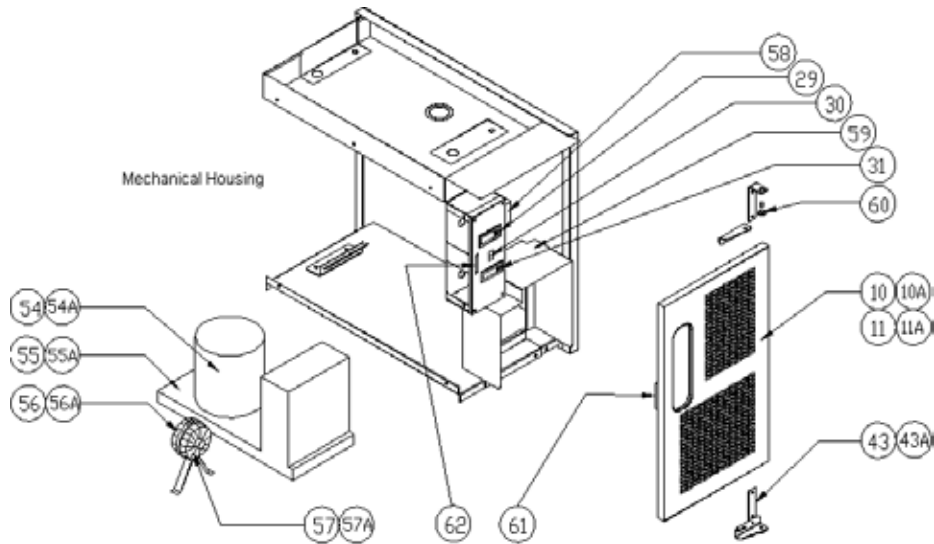

ITEM	DESCRIPTION	PART #
1	Order/Note Holder Slide, PH48SPA Units	HD SLDOSR4
1A	Order/Note Holder Slide, PH66SPA Units	HD SLD9901
2	Pan Rail Slide Back Lid, PH48SPA Units	RP LID0501
2A	Pan Rail Slide Back Lid, PH66SPA Units	RP LID0502
3	1/3 Size Pan, Scrap Catch	HD PAN037
4	Drawer Front, 27" Extendable, Top	RP FRT05T
4A	Drawer Front, 27" Extendable, Bottom	RP FRT05B
5	Sculptured Handle, 12 13/16"	HD HDL130
6	Paper Towel Dispenser Holder	RP BRK0500
7	Bracket for 1/9 size pan	RP BRK0417
8	Overshelf Assembly, PH48SPA Units	RP OSH0500
8A	Overshelf Assembly, PH66SPA Units	RP OSH0501
9	Cutting Board, 1" x 13" x 18 1/2", PH48SPA Units only	RP CPO1318
9A	Cutting Board, 1" x 13" x 20", PH66SPA Units only	RP CPO1320
10	Left Hinged Louver for Mech. Housing, PH48SPA Units	RP LVR0500
10A	Right Hinged Louver for Mech. Housing, PH48SPA Units	RP LVR0501
11	Left Hinged Louver for Mech. Housing, PH66SPA Units	RP LVR0502
11A	Right Hinged Louver for Mech. Housing, PH66SPA Units	RP LVR0503
12	Caster, 4" Overall with locking mechanism	HD CST030
12A	Caster, 4" Overall without locking mechanism	HD CST031
13	Vertical Adaptor Bar for Rail, 20 3/4" L with slots	PH BAR0500
13A	Vertical Adaptor Bar for Rail, 21"L x 2"W 6-Slot, PH66SPA	PH BAR221
14	Horizontal Adaptor Bar for Rail, 6 1/3" L both end hook	PH BAR0501
14A	Horizontal Adaptor Bar for Rail, 12" L both end hook w/center slot, PH66SPA Units only	PH BAR0505
15	Horizontal Adaptor Bar for Rail, 4 1/4" L both end hook	PH BAR0502
16	Elbow, 1 1/2" PVC Fem x Glue	PB ELB9905
17	Pipe, 1 1/2" PVC	PB PIP150
18	Ball Valve, 1 1/2" PVC Female	PB VLV9901
19	Rod Style Cutting Board Holders with Stops, Set of 2	RP SLD0500
20	Evaporator Coil, 38"x4"x1" with brackets for PH48SPA	RF COI0304
20A	Evaporator Coil, 53"x4"x1" with brackets for PH66SPA	RF COI0002
21	Drain Screen, 2"	RP DSN002
22	Evaporator Fan Motor, Rail	EL MTR0101
23	Fan Mounting Box	RP BRK0501

24	Duct Box for PH48SPA Units	RP DCT0500
24A	Duct Box Left for PH66SPA Units	RP DCT0501
24B	Duct Box Right for PH66SPA Units	RP DCT0502
25	Fan Shroud, Rail, PH48SPA Units	RP SHD0500
25A	Fan Shroud, Rail, PH66SPA Units	RP SHD0501
26	Fan Register, Front, PH48SPA Units	RP REG0500
26A	Fan Register, Front, PH66SPA Units	RP REG0501
27	Fan Register, Middle, PH48SPA Units	RP REG0502
27A	Fan Register, Middle, PH66SPA Units	RP REG0503
28	Fan Register, Back, PH48SPA Units	RP REG0504
28A	Fan Register, Back, PH66SPA Units	RP REG0505
29	Dixell Temperature Control for Rail	RF CNT0101
30	Rocker On/Off Switch	EL SWT140
31	Digital Thermometer for Base	HD THR0006
32	Mounting Support for Base Coil Assembly	RP SPT0500
33	Evaporator Fan Motor, Base	EL MTR2338
34	Dial Temperature Control for Base	HD CNT200
35	Plastic Bottom for Base Coil Assembly Box	RP DRP107
36	Evaporator Coil Assembly	RP CSY108SL
36A	Evaporator Coil	RF COI107
37	Refrigeration Valve for Base Coil Assembly	RF VLV404
38	Fan Mounting Bracket for Base Coil Assembly	RP SHD107
39	Solenoid Valve for Base Coil Assembly	RF SOL9801
40	Shield Panel for Base Coil Assembly	RP PNL107
41	Shelf Holding Pin, PH66SPA Units	HD PIN0102
42	Door Gasket, PH66SPA Units	IN GSK9902
43	Strap Hinge Assembly for Right Hinging	RP HNG9901
43A	Strap Hinge Assembly for Left Hinging	RP HNG9902
44	Door with Handle, Left Hinge, PH66SPA Units	PH DOR0500
44A	Door with Handle, Right Hinge, PH66SPA Units	PH DOR0501
45	Shelf, 25 " x 16 1/8" Gray Wire Powder Coated	HD SHL9912
46	Drawer Gasket	IN GSK1070
47	Drawer Frame	RP FRM127E
48	Adaptor Bar for Drawer, 20" L Lock-in w/ slots	PH BAR0506
49	Adaptor Bar for Drawer, 12 "L lock-in w/slot hooks	PH BAR0507
50	Roller Bearings for Drawer	HD BRG210
51	Drawer Track Set, 2pc.	RP TRK05SM
52	Thumb Screw	HD PIN107
53	Mounting Plate for Drawer	RP MPT027
54	Compressor, PH48SPA Units	RF CMP0403
54A	Compressor, PH66SPA Units	RF CMP0404
55	Condensing Unit, PH48SPA Units	RF CON0401
55A	Condensing Unit, PH66SPA Units	RF CON0402
56	Condenser Fan Motor, PH48SPA Units	RF MTR0501
56A	Condenser Fan Motor, PH66SPA Units	RF MTR0103
57	Condenser Fan Blade, PH48SPA Units	RF FAN0501
57A	Condenser Fan Blade, PH66SPA Units	RF FAN0502
58	Pressure Control	RF CNT750
59	Condensing Unit Shroud, PH48SPA Units	RP SHD0502
59A	Condensing Unit Shroud, PH66SPA Units	RP SHD0503
60	Bushing for Strap Hinge	HD BSH050
61	Magnetic Catch for Louver Door	HD CTH9901
62	Magnet Striker Plate	HD STR9901