

## OPERATOR'S MANUAL

This manual provides information on installation, operating, maintenance, trouble shooting & replacement parts for

# LOW PROFILE EQUIPMENT STANDS 20000 SERIES



### **NOTIFY CARRIER OF DAMAGE AT ONCE.**

It is the responsibility of the consignee to inspect the container upon receipt of same and to determine the possibility of any damage, including concealed damage. Unified Brands suggests that if you are suspicious of damage to make a notation on the delivery receipt. It will be the responsibility of the consignee to file a claim with the carrier. We recommend that you do so at once.



525 South Coldwater Road • Weidman, MI 48893  
888-994-7636 • Fax 888-864-7636 • [unifiedbrands.net](http://unifiedbrands.net)

## Table of Contents

page 2.....	Congratulations
page 3.....	Parts & Service Hotline
page 3.....	Serial Number Location
page 4-7.....	Randell Limited Warranty
page 8.....	Unit Specifications
page 9-10.....	Unit Installation
page 11.....	Electrical Diagrams
page 12-13.....	Unit Operation
page 14-15.....	Preventive Maintenance
page 16-17.....	Troubleshooting
page 18-21.....	Replacement Parts

Congratulations on your recent purchase of Randell food service equipment, and welcome to the growing family of satisfied Unified Brands customers.

Our reputation for superior products is the result of consistent quality craftsmanship. From the earliest stages of product design to successive steps in fabrication and assembly, rigid standards of excellence are maintained by our staff of designers, engineers, and skilled employees.

Only the finest heavy-duty materials and parts are used in the production of Randell brand equipment. This means that each unit, given proper maintenance will provide years of trouble free service to its owner.

**In addition, all Randell food service equipment is backed by some of the best warranties in the food service industry and by our professional staff of service technicians.**

**Retain this manual for future reference.**

**NOTICE:** Due to a continuous program of product improvement, Unified Brands reserves the right to make changes in design and specifications without prior notice.

**NOTICE:** Please read the entire manual carefully before installation. If certain recommended procedures are not followed, warranty claims will be denied.

<p><b>MODEL NUMBER</b> _____</p> <p><b>SERIAL NUMBER</b> _____</p> <p><b>INSTALLATION DATE</b> _____</p>
--

The serial number is located in the mechanical housing.

**800-621-8560**

**Randell Service and Parts  
Hotline**

## Warranty Policies

Unified Brands believes strongly in the products it builds and backs them with the best warranty in the industry. Standard with every unit comes the peace of mind that this unit has been thoroughly engineered, properly tested and manufactured to excruciating tolerances, by a manufacturer with over 35 years of industry presence. On top of that front end commitment, Unified Brands has a dedicated staff of certified technicians that monitor our own technical service hotline at **1-800-621-8560** to assist you with any questions or concerns that may arise after delivery of your new Randell equipment.

### **PARTS WARRANTY**

1. One year parts replacement of any and all parts that are found defective in material or workmanship. Unified Brands warrants all component parts of manufactured new equipment to be free of defects in material or workmanship, and that the equipment meets or exceeds reasonable industry standards of performance for a period of one year from the date of shipment from any Unified Brands factory, assembly plant or warehouse facility.

**NOTE: Warranties are effective from date of shipment, with a thirty day window to allow for shipment, installation and set-up. In the event equipment was shipped to a site other than the final installation site, Unified Brands will warranty for a period of three months following installation, with proof of starting date, up to a maximum of fifteen months from the date of purchase.**

2. Free ground freight of customer specified location for all in warranty parts within continental U.S. Component part warranty does not cover glass breakage or gasket replacement. Unified Brands covers all shipping cost related to component part warranty sent at regular ground rates (UPS, USPS). **Freight or postage incurred for any express or specialty methods of shipping are the responsibility of the customer.**

### **LABOR COVERAGE**

In the unlikely event a Randell manufactured unit fails due to defects in materials or workmanship within the first ninety days, Unified Brands agrees to pay the contracted labor rate performed by an **Authorized Service Agent (ASA)**. Any warranty work performed by a non-ASA will not be honored by Unified Brands. A complete listing of current ASAs can be found on the Randell page of our web site : [www.unifiedbrands.net](http://www.unifiedbrands.net). Warranties are effective from date of shipment, with a thirty day window to allow for shipment, installation and setup. Where equipment is shipped to any site other than final installation, Unified Brands will honor the labor warranty for a period of ninety

days following installation with proof of starting date, up to a maximum of six months from date of purchase.

**Temperature adjustments are not covered under warranty**, due to the wide range of ambient conditions.

To request a warranty approval number, call our Field Service Department at: 1-800-621-8560

#### **WHEN OPTIONAL 5 YEAR COMPRESSOR WARRANTY APPLIES**

1. Provide reimbursement to an ASA for the cost of locally obtained replacement compressor in exchange for the return of the defective compressor sent back freight prepaid. Note: Unified Brands does limit amount of reimbursement allowed and does require bill from local supply house where compressor was obtained (customer should not pay servicing agent up front for compressor).
2. Provide repair at the manufacturing facility by requiring that the defective unit be sent back to Unified Brands freight prepaid. Perform repair at the expense of Unified Brands and ship the item back to the customer freight collect.
3. Furnish complete condensing unit freight collect in exchange for the return of the defective compressor sent back freight prepaid. (Decisions on whether or not to send complete condensing units will be made by Randell's in-house service technician).

#### **WHEN OPTIONAL LABOR EXTENSION POLICY APPLIES**

Unified Brands will provide reimbursement of labor invoiced to an ASA for any customer that has an optional labor extension of our standard warranty. (Contracted rates do apply) Randell offers both 1 and 2 year extensions. Labor extensions begin at the end of our standard warranty and extend out 9 months to 1 calendar year or 21 months to 2 calendar years from date of purchase. Please contact Randell technical support at 1-800-621-8560 for details and any question on **Authorized Service Agents (ASA)**.

#### **EXCLUSIVE DRAWER CARTRIDGE WARRANTY**

The patented Randell drawer cartridges are covered by a 3 year parts and labor warranty. This warranty covers any malfunction with the drawer system as the result of workmanship or failed components. Gaskets are not covered under the warranty as gaskets are a maintenance item.

#### **WHEN EXPORT WARRANTIES APPLY**

1. Unified Brands covers all non-electrical components under the same guidelines as our standard domestic policy.
2. All electrical components operated on 60 cycle power are covered under our standard domestic policy.
3. All electrical components operated on 50 cycle power are covered for 90 days from shipment only.
4. Extended warranty options are not available from the factory.

#### **ITEMS NOT COVERED UNDER WARRANTY**

1. Maintenance type repairs such as condenser cleaning, temperature adjustments, clogged drains and unit leveling.

2. Randell does not cover gaskets under warranty. Gaskets are a maintenance type component that are subject to daily wear and tear and are the responsibility of the owner of the equipment. Because of the unlimited number of customer related circumstances that can cause gasket failure all gasket replacement issues are considered non-warranty. Randell recommends thorough cleaning of gaskets on a weekly basis with a mild dish soap and warm water. With proper care Randell gaskets can last up to two years, at which time we recommend replacement of all gaskets on the equipment for the best possible performance.

**NOTICE: FOOD LOSS IS NOT COVERED UNDER WARRANTY**

3. Repairs caused by abuse such as broken glass, freight damage, or scratches and dents.
4. Electrical component failure due to water damage from cleaning procedures.
5. Repairs due to improper installation.

**QUOTATIONS**

Verbal quotations are provided for customer convenience only and are considered invalid in the absence of a written quotation. Written quotations from Unified Brands are valid for 30 days from quote date unless otherwise specified. Unified Brands assumes no liability for dealer quotations to end-users.

**SPECIFICATION & PRODUCT DESIGN**

Due to continued product improvement, specification and product design may change without notice. Such revisions do not entitle the buyer to additions. Changes or replacements for previously purchased equipment.

**SANITATION REQUIREMENTS**

Certain areas require specific annotation requirements other than N.S.F. & U.L. standards. Unified Brands must be advised of these specifications before fabrication of equipment. In these special circumstances, a revised quotation may be required to cover additional costs. Failure to notify Unified Brands before fabrication holds the dealer accountable for all additional charges.

**CANCELLATIONS**

Orders canceled prior to production scheduling entered into engineering/production and cancelled are subject to a cancellation charge (contact factory for details).

**STORAGE CHARGES**

Unified Brands makes every effort to consistently meet our customer's shipment expectations. If after the equipment has been fabricated, the customer requests delay in shipment, and warehousing is required:

1. Equipment held for shipment at purchasers request for a period of 30 days beyond original delivery date specified will be invoiced and become immediately payable.
2. Equipment held beyond 30 days after the original delivery date specified will also include storage charges.

## **SHIPPING & DELIVERY**

Unified Brands will attempt to comply with any shipping, routing or carrier request designated by dealer, but reserves the right to ship merchandise via any responsible carrier at the time equipment is ready for shipment. Randell will not be held responsible for any carrier rate differences; rate differences are entirely between the carrier and purchaser. Point of shipping shall be determined by Unified Brands (Weidman, MI/Jackson, MS). At dealer's request, Unified Brands will endeavor whenever practical to meet dealer's request. Freight charges to be collect unless otherwise noted.

## **DAMAGES**

All crating conforms to general motor carrier specifications. To avoid concealed damage, we recommend inspection of every carton upon receipt. In the event the item shows rough handling or visible damage to minimize liability, a full inspection is necessary upon arrival. Appearance of damage will require removing the crate in the presence of the driver. **A notation must be placed on the freight bill and signed for by the truck driver at the time of delivery.** Any and all freight damage that occurs to a Randell piece of equipment as a result of carrier handling is not considered under warranty, and is not covered under warranty guidelines. Any freight damage incurred during shipping needs to have a freight claim filed by the receiver with the shipping carrier. Consignee is responsible for filing of freight claims when a clear delivery receipt is signed. Claims for damages must be filed immediately (within 10 days) by the consignee with the freight carrier and all cartons and merchandise must be retained for inspection.

## **RETURNED GOODS**

Authorization for return must first be obtained from Unified Brands before returning any merchandise. Any returned goods shipment lacking the return authorization number will be refused, all additional freight costs to be borne by the returning party. Returned equipment must be shipped in original carton, freight prepaid and received in good conditions. Any returned merchandise is subject to a minimum handling charge (consult factory for rate).

## **INSTALLATION**

Equipment installation is the responsibility of the dealer and/or their customer. Unified Brands requires all equipment to be professionally installed.

## **PENALTY CLAUSES**

Dealer penalty clauses, on their purchase order or contractually agreed to between the dealer and their clients are not binding on Unified Brands. Unified Brands does not accept orders subject to penalty clauses. This agreement supersedes any such clauses in dealer purchase orders.

## **EXPORT POLICY**

All quotations for export sales will be handled by Unified Brands exporting agent. For inquiries on export please contact Unified Brands customer support staff at 1-800-621-8560.

\*FOOTNOTES IN REFERENCE TO PARAGRAPHS ABOVE

1. Herein called Randell.
2. NET means list price less discount, warranty, labor policy, freight, Randell delivery and other miscellaneous charges.

# Unit Specifications



20072SC shown

Model	L	D	H	Drawers	12x20x4 Pan Capacity	H.P.	Volts	Amps	NEMA	Ship Wt.
<b>Self Contained</b>										
20048SC	48"	32.5"	26"	(2)27"ext.	4	1/4	115	6	5-15P	400
20048SC-C4	48"	32.5"	24"	(2)27"ext.	4	1/4	115	6	5-15P	400
20072SC	72"	32.5"	26"	(4)27"ext.	8	1/3	115	7.4	5-15P	530
20072SC-C4	72"	32.5"	24"	(4)27"ext.	8	1/3	115	7.4	5-15P	530
20078SC	78"	32.5"	26"	(4)27"ext.	8	1/3	115	7.4	5-15P	550
20078SC-C4	78"	32.5"	24"	(4)27"ext.	8	1/3	115	7.4	5-15P	550
20105SC	105"	32.5"	26"	(6)27"ext.	12	3/8	115	10.9	5-15P	675
20105SC-32	120"	32.5"	24"	(6)32"ext.	12	1/2	115	12	5-15P	675
20048SCF	48"	32.5"	26"	(2)27"ext.	4	1/3	115	8.7	5-15P	400
20072SCF	72"	32.5"	26"	(4)27"ext.	8	1/3	115	8.7	5-15P	530
20105SCF	105"	32.5"	26"	(6)27"ext.	12	1/2	115	10.9	5-15P	675
Model	L	D	H	Drawers	12x20x4 Pan Capacity	BTU	Volts	Amps	NEMA	Ship Wt.
<b>Remote</b>										
20042R	42"	32.5"	26"	(2)27"ext.	4	466	115	3	N/A	330
20065R	65"	32.5"	26"	(4)27"ext.	8	823	115	3	N/A	460
20092R	92"	32.5"	26"	(6)27"ext.	12	1300	115	4	N/A	600
20042RF	42"	32.5"	26"	(2)27"ext.	4	619	115	6	N/A	330
20065RF	65"	32.5"	26"	(4)27"ext.	8	1093	115	6	N/A	460
20092RF	92"	32.5"	26"	(6)27"ext.	12	1726	115	8.5	N/A	600

Models with suffix SC are self-contained refrigerated units, SCF are self-contained freezer units, and SC-C4 are self-contained refrigerated units with heavy-duty 4" casters.

Models with suffix R are remote refrigerated units.



# Unit Installation

## SELECTING A LOCATION FOR YOUR NEW UNIT

The following conditions should be considered when selecting a location for your unit:

1. **Floor Load:** The area on which the unit will rest must be level, free of vibration, and suitably strong enough to support the combined weights of the unit plus the maximum product load weight. All casters or legs must in contact with the floor. Adjust legs or add shims to casters for uneven floor surfaces.  
**NOTE: Randell's Low Profile Equipment Stands are designed to support the weight of standard cooking equipment, such as griddles, fryers, and cook top ranges. For non-standard cooking equipment or if there is a question pertaining to weight load limits, consult the factory at 1-800-621-8560.**
2. **Clearance:** There must be a combined total of at least 3" clearance on all sides of the unit.
3. **Ventilation:** The air cooled self contained unit requires a sufficient amount of cool clean air. Avoid surrounding your equipment stand around other heat generating equipment and out of direct sunlight. Also, avoid locating in an unheated room or where the room temperature may drop below 55° F or about 90° F.

## INSTALLATION CHECKLIST

After the final location has been determined, refer to the following checklist prior to start-up:

1. Check all exposed refrigeration lines to ensure that they are not kinked, dented, or rubbing together.
2. Check that the condenser and evaporator fans rotate freely without striking any stationary members.
3. Unit must be properly leveled; check all legs or casters to ensure they all are in contact with the floor while maintaining a level work surface. Adjusting bullet feet heights or shimming casters may be necessary if the floor is not level. **NOTE: Damage to equipment may result if not followed. Unified Brands is not responsible for damage to equipment if improperly installed.**
4. Plug in unit and turn on main on/off power switch.
5. Allow unit time to cool down to temperature. If temperature adjustments are required, the temperature control is located within the cabinet on the front face of the evaporator coil behind the thermometer (Note: The left set of drawers or center set for a 6 drawer unit must be removed to access the temperature adjustment control).
6. Refer to the front of this manual for serial number location. Please record this information in your manual on page 3 now. It will be necessary when ordering replacement parts or requesting warranty service.
7. Confirm that the unit is holding temperature. Set controls to desired temperature for your particular ambient and altitude.

8. Allow your unit to operate for approximately 2 hours before putting in food to allow interior of unit to cool down to storage temperature.

**NOTE: All motors are oiled and sealed.**

**NOTE: FAILURE TO FOLLOW INSTALLATION GUIDELINES AND RECOMMENDATIONS MAY VOID THE WARRANTY ON YOUR UNIT.**

**ELECTRICAL SUPPLY:** The wiring should be done by a qualified electrician in accordance with local electrical codes. A properly wired and grounded outlet will assure proper operation. Please consult the data tag attached to the compressor to ascertain the correct electrical requirements. Supply voltage and amperage requirements are located on the serial number tag located inside the mechanical housing.

**NOTE: It is important that a voltage reading be made at the compressor motor electrical connections, while the unit is in operation to verify the correct voltage required by the compressor is being supplied. Low or high voltage can detrimentally affect operation and thereby void its warranty.**

**NOTE: it is important that your unit has its own dedicated line. Condensing units are designed to operate with a voltage fluctuation of plus or minus 10% of the voltage indicated on the unit data tag. Burn out of a condensing unit due to exceeding voltage limits will void the warranty.**

# Electrical Diagrams

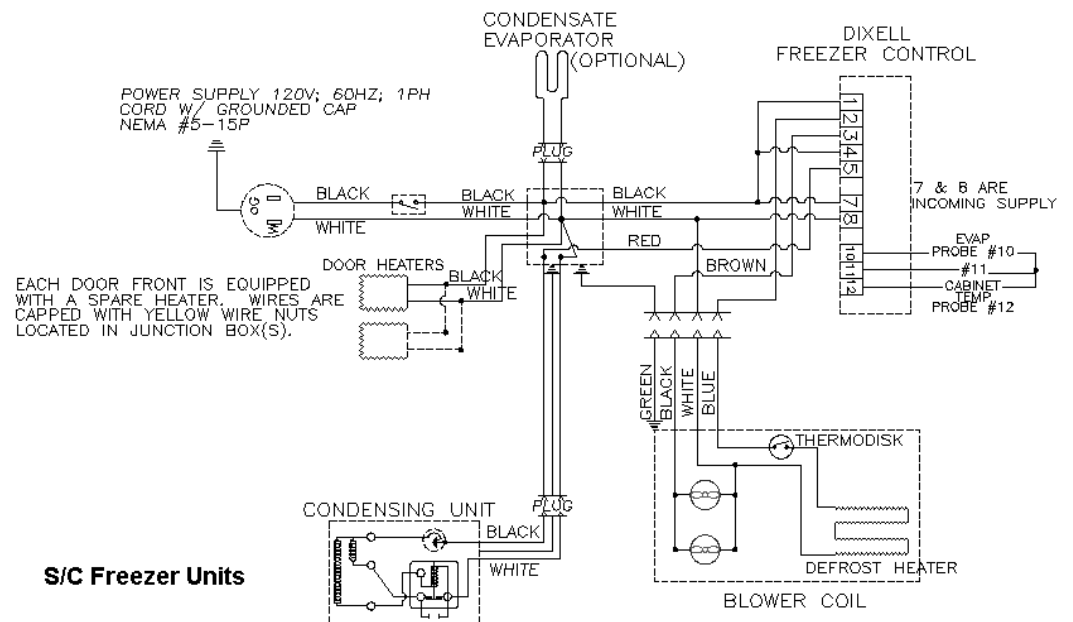
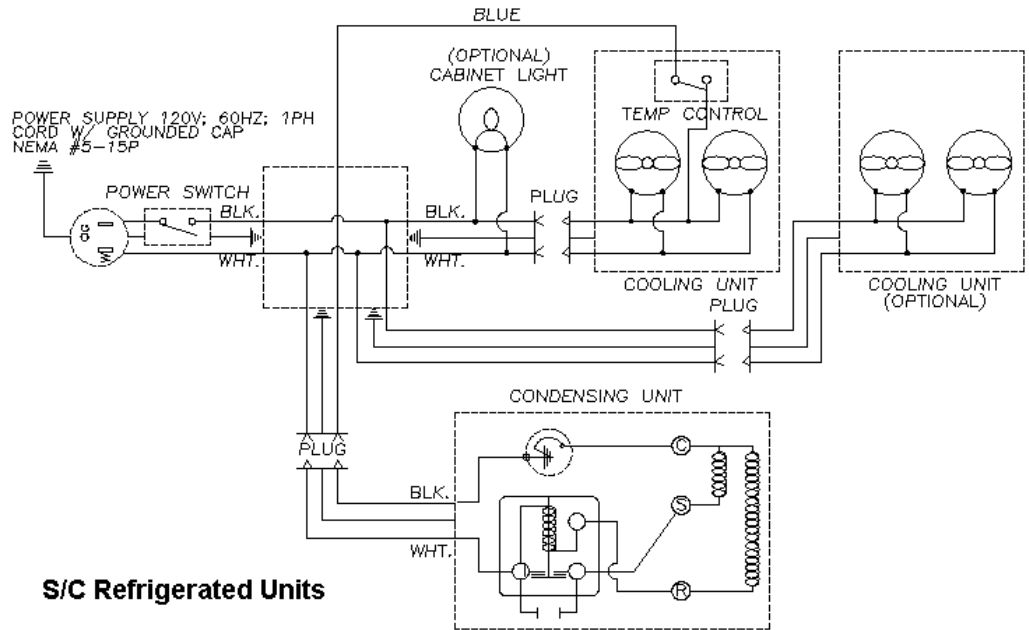

## Unit Operation

Randell has attempted to preset the cold controls to ensure that your unit runs at an optimum temperature, but due to varying ambient conditions, including elevation, food product as well as type of operation, you may need to alter this temperature.

It is strongly recommended that the drawers be kept closed when the unit is not in use and between rush periods. This is especially important in the summer and in kitchens exceeding 86° F. Do not leave the drawers open for prolonged periods of time.

**NOTE: Even though your equipment stand was designed for heavy use, excessive drawer openings should be avoided in order to maintain proper cabinet temperature and eliminate the possibility of coil freeze-up.**

### TEMPERATURE CONTROL

Your equipment stand was equipped with a temperature adjustment control located within the cabinet on the front face of the evaporator coil behind the thermometer (Note: The left set of drawers or center set for a 6 drawer unit must be removed to access the temperature adjustment control).

#### To adjust the temperature in refrigerated units:

- A. To lower the temperature:
  - 1. Turn the dial knob clockwise.
  - 2. There are numbers to indicate settings. Keep the arrow on the knob pointed within the numbered section of the arc.
  - 3. Turning it clockwise beyond the numbered section can result in freeze-up.
- B. To raise the temperature:
  - 1. Turn the dial knob counterclockwise.
  - 2. There are numbers to indicate settings. Keep the arrow on the knob pointed within the numbered section of the arc.
  - 3. Turning it counterclockwise beyond the numbered section will shut the compressor off.

**NOTE: It is not recommended to turn the dial above 8 or below 1 on the temperature control. If the adjustments still do not result in proper temperature please contact the factory at 1-800-621-8560.**

- C. If your temperature control is at the maximum setting and the cabinet temperature still remains too low or too high, you may need to adjust the pressure control.
  - 1. Turn the right adjustment screw clockwise (1/4 turn at a time) to a lower number for a colder temperature.
  - 2. Turn the right adjustment screw counterclockwise (1/4 turn at a time) to a higher number for a warmer temperature.

**NOTE: Numbers on pressure control are pounds of pressure, not degrees F.**

**NOTE: Do not adjust the differential screw.**

**To adjust the temperature in freezer units:**

- A. Push and hold the “set” button until 12 appears and then release the “set” button. 12 is the current set point temperature. **NOTE: Standard freezer units are preset to operate at 12° F.**
- B. **To lower the temperature**, push and release the up arrow 2 times until 10 is displayed. Push and release the “set” button one time. The new set point, 10 will flash 3 times and then will be locked in.
- C. **To raise the temperature**, push and release the down arrow 2 times until 14 is displayed. Push and release the “set” button one time. The new set point, 14, will flash 3 times and then will be locked in.

**NOTE: It is recommended to only make changes of 2 degree increments at a time. Allow for the unit to operate 24 hours between adjustments. If the 2 degree adjustment is not enough another adjustment can be made. The maximum highest setting is 25 degrees and the minimum lowest setting is 5 degrees. If the settings need to go above or below this point there may be other contributing factors as to the cause of the temperature variances, please contact the factory at 1-800-621-8560.**

## Preventive Maintenance

Unified Brands strongly suggests a preventive maintenance program which would include the following **Monthly** procedures:

1. Cleaning of all condenser coils. Condenser coils are a critical component in the life of the compressor and must remain clean to assure proper air flow and heat transfer. Failure to maintain this heat transfer will affect unit performance and eventually destroy the compressor. Clean the condenser coils with coil cleaner and/or a vacuum, cleaner and brush.

**NOTE: Brush coil in direction of fins, normally vertically as to not damage or restrict air from passing through condenser.**

2. Clean fan blade on the condensing unit.
3. Clean and disinfect drains with a solution of warm water and mild detergent
4. Clean and disinfect drain lines and evaporator pan with a solution of warm water and mild detergent
5. Clean all gaskets on a weekly if not daily basis with a solution of warm water and a mild detergent to extend gasket life.
6. Remove debris from drawer slides.

**NOTE: DO NOT USE SHARP UTENSILS.**

**RECOMMENDED CLEANERS FOR YOUR STAINLESS STEEL INCLUDE THE FOLLOWING:**

JOB	CLEANING AGENT	COMMENTS
Routine cleaning	Soap, ammonia, detergent Medallion	Apply with a sponge or cloth
Fingerprints and smears	Arcal 20, Lac-O-Nu, Ecoshine	Provides a barrier film
Stubborn stains and discoloration	Cameo, Talc, Zud, First Impression	Rub in the direction of the polish lines
Greasy and fatty acids, blood, burnt-on foods	Easy-Off, Degrease It, Oven Aid	Excellent removal on all finishes
Grease and Oil	Any good commercial detergent	Apply with a sponge or cloth
Restoration/Preservation	Benefit, Super Sheen	Good idea monthly

Reference: Nickel Development Institute, Diversey Lever, Savin, Ecolab, NAFEM.

**NOTE: Do not use steel pads, wire brushes, scrapers, or chloride cleaners to clean your stainless steel. CAUTION: DO NOT USE ABRASIVE CLEANING SOLVENTS, AND NEVER USE HYDROCHLORIC ACID (MURIATIC ACID) ON STAINLESS STEEL.**

**NOTE: Do not pressure wash equipment as damage to electrical components may result.**

## **DRAWER REMOVAL AND INSTALLATION**

### **Drawer Removal:**

To remove the individual drawer:

1. Fully extend the drawer that is to be removed.
2. Remove product pans from drawer.
3. Lift up the drawer stop tabs on each side of drawer track.
4. Pull drawer out while lifting the tabs.



To remove and re-install drawer tracks, please refer to Figure 2 below for proper installation instructions.

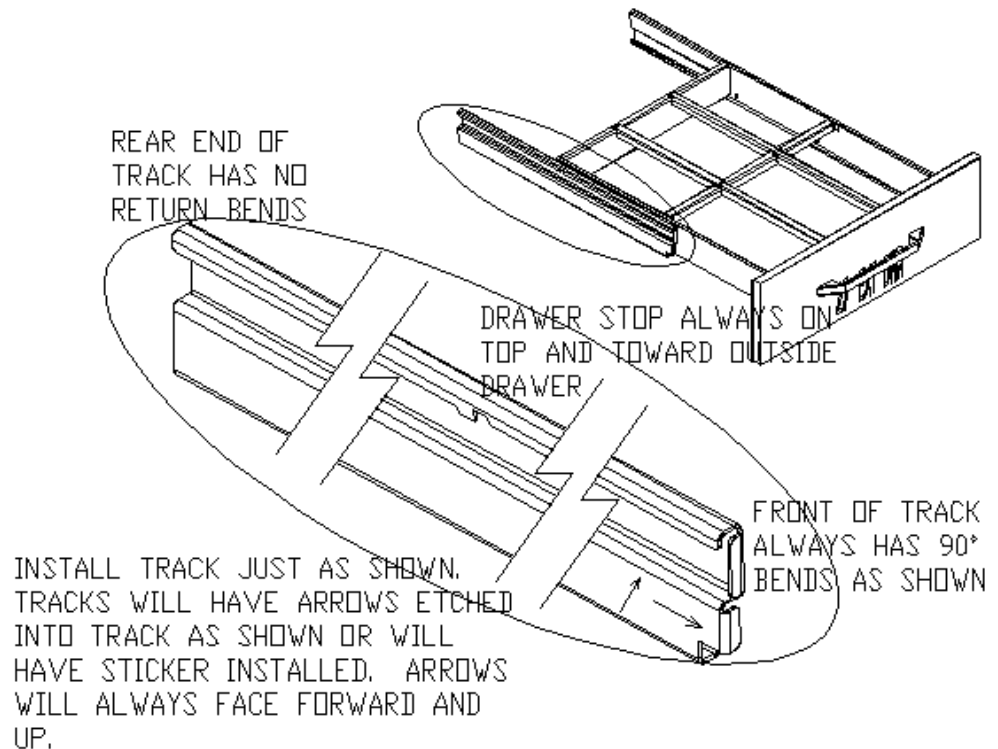

Proper maintenance of equipment is the ultimate necessity in preventing costly repairs. By evaluating each unit on a regular schedule, you can often catch and repair minor problems before they completely disable the unit and become burdensome on your entire operation.

**For more information on preventive maintenance, consult your local service company or CFESA member.** Most repair companies offer this service at very reasonable rates to allow you the time you need to run your business along with the peace of mind that all your equipment will last throughout its expected life. These services often offer guarantees as well as the flexibility in scheduling or maintenance for your convenience.

Unified Brands believes strongly in the products it manufactures and backs those products with one of the best warranties in the industry. We believe with the proper maintenance and use, you will realize a profitable return on your investment and years of satisfied service.

## Trouble Shooting Guide

SYMPTOM	POSSIBLE CAUSE	PROCEDURE
Unit doesn't run	<ol style="list-style-type: none"> <li>1. No power to unit</li> <li>2. Temperature control turned off</li> <li>3. Temperature control faulty</li> <li>4. Compressor overheated</li> <li>5. Condenser fan faulty</li> <li>6. Overload protector faulty</li> <li>7. Compressor relay faulty</li> </ol>	<ol style="list-style-type: none"> <li>1. Plug in unit</li> <li>2. Check temperature control</li> <li>3. Test temperature control</li> <li>4. Clean condenser coil</li> <li>5. Service condenser fan</li> <li>6. Test overload</li> <li>7. Test relay</li> </ol>
Unit short cycles	<ol style="list-style-type: none"> <li>1. Condenser coil dirty</li> <li>2. Condenser fan faulty</li> <li>3. Compressor faulty</li> <li>4. Overload repeatedly tripping</li> </ol>	<ol style="list-style-type: none"> <li>1. Clean coil</li> <li>2. Service fan and motor.</li> <li>3. Call for service at <b>800-621-8561</b></li> <li>4. Check outlet voltage</li> </ol>
Unit runs constantly	<ol style="list-style-type: none"> <li>1. Frost build-up</li> <li>2. Drawer not sealing properly</li> <li>3. Drawer gasket damaged</li> <li>4. Condenser coil dirty</li> <li>5. Condenser fan faulty</li> </ol>	<ol style="list-style-type: none"> <li>1. Defrost evaporator</li> <li>2. Check drawer seal</li> <li>3. Replace drawer gasket</li> <li>4. Clean coil</li> <li>5. Service condenser motor</li> </ol>
Unit not cold enough	<ol style="list-style-type: none"> <li>1. Temperature control set too high</li> <li>2. Temperature control faulty</li> <li>3. Condenser coil dirty</li> <li>4. Drawer not sealing properly</li> <li>5. Drawer gasket damaged</li> <li>6. Evaporator fan faulty</li> <li>7. Evaporator iced up</li> </ol>	<ol style="list-style-type: none"> <li>1. Adjust control to lower setting</li> <li>2. Test control</li> <li>3. Clean coil</li> <li>4. Check drawer seal</li> <li>5. Replace drawer gasket</li> <li>6. Service evaporator fan</li> <li>7. Check drawer seal</li> </ol>



Unit too cold	<ol style="list-style-type: none"> <li>1. Temperature control set too low</li> <li>2. Temperature control faulty</li> </ol>	<ol style="list-style-type: none"> <li>1. Adjust control to raise setting</li> <li>2. Test control</li> </ol>
Unit doesn't defrost	<ol style="list-style-type: none"> <li>1. Defrost heater faulty</li> </ol>	<ol style="list-style-type: none"> <li>1. Test defrost heater</li> </ol>
Moisture around drawer or frame	<ol style="list-style-type: none"> <li>1. Breaker strips faulty</li> <li>2. Frame heater defective</li> <li>3. Temperature set too low</li> </ol>	<ol style="list-style-type: none"> <li>1. Inspect strips</li> <li>2. Call for service at <b>800-621-8561</b></li> <li>3. Raise temperature setting</li> </ol>
Drawer does not stay in	<ol style="list-style-type: none"> <li>1. Tracks inserted incorrectly</li> <li>2. Roller bearings broken</li> </ol>	<ol style="list-style-type: none"> <li>1. Refer to Drawer Installation</li> <li>2. Call ASA for Service</li> </ol>
Ice in drain pan or water in bottom of unit or floor	<ol style="list-style-type: none"> <li>1. Drain tube clogged</li> <li>2. Unit not level</li> </ol>	<ol style="list-style-type: none"> <li>1. Clean drain</li> <li>2. Adjust leveling leg/shim casters</li> </ol>
Unit noisy	<ol style="list-style-type: none"> <li>1. Unit not level</li> <li>2. Compressor mountings loose or hardened.</li> <li>3. Condenser fan damaged or hitting fan shroud</li> <li>4. Evaporator fan damaged or hitting fan shroud</li> <li>5. Mechanical compartment louver rattling</li> </ol>	<ol style="list-style-type: none"> <li>1. Adjust leveling leg/shim casters</li> <li>2. Tighten or replace compressor mountings</li> <li>3. Inspect condenser fan</li> <li>4. Inspect evaporator fan</li> <li>5. Bend or align tabs to reduce noise. Replace if necessary.</li> </ol>

# Replacement Parts

# 20000 Series Low Profile Equipment Stands

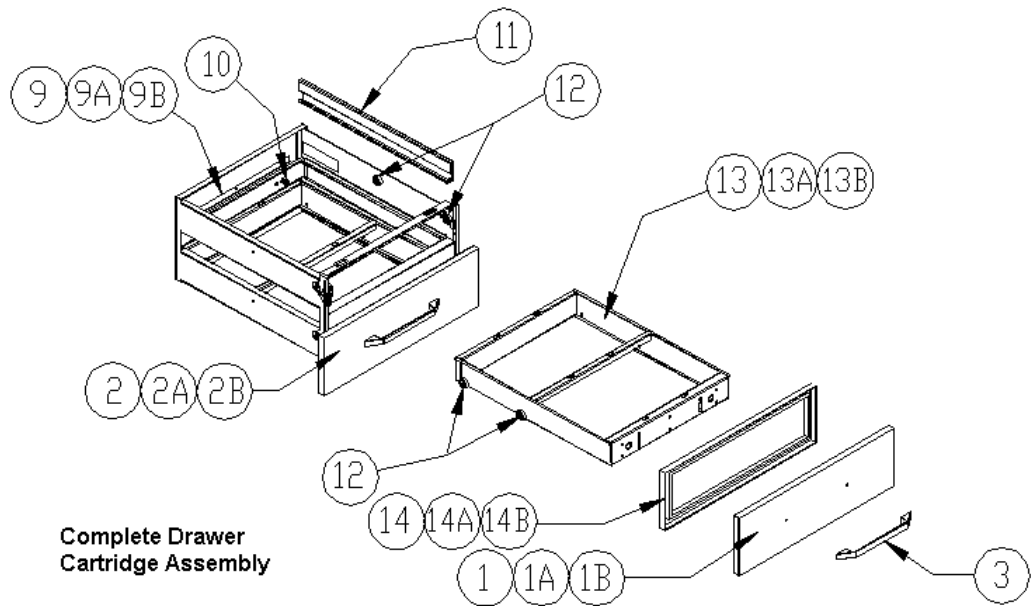
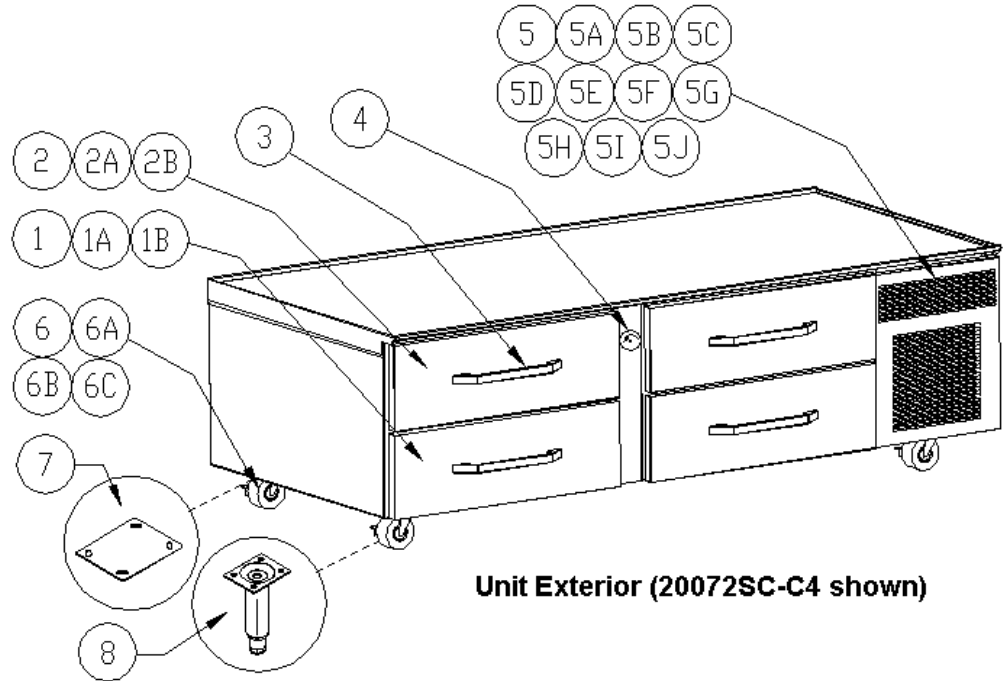

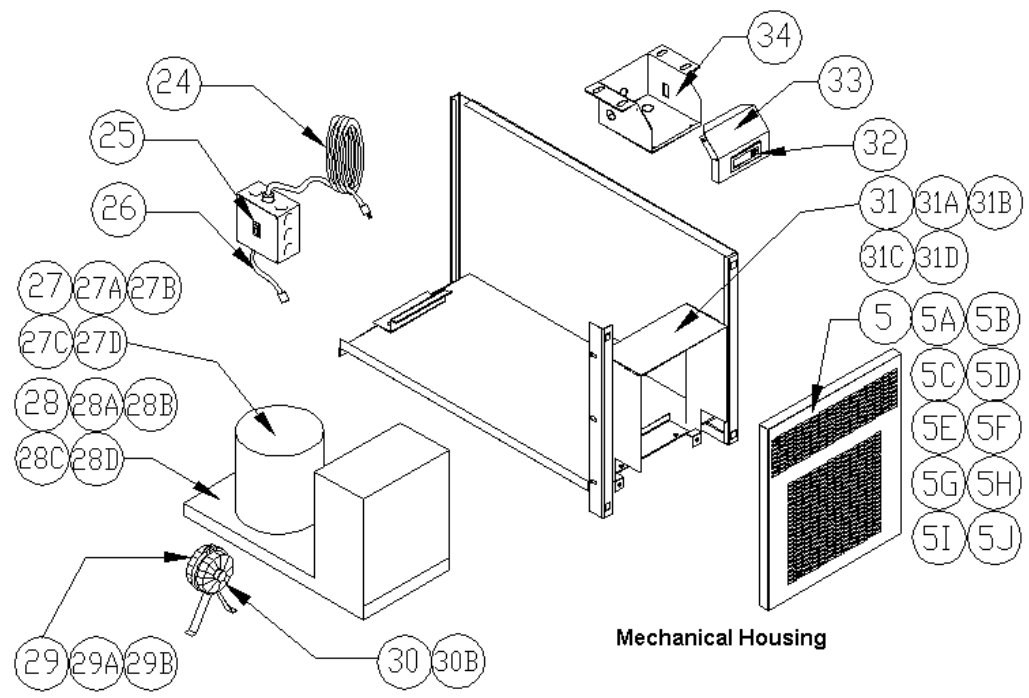
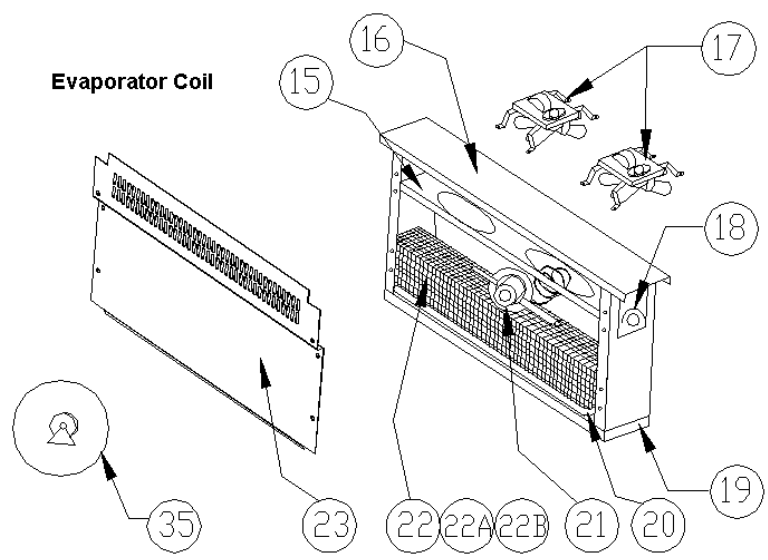

ITEM	DESCRIPTION	PART #
1	Drawer Front, 27", Top	RP FRT05T
1A	Drawer Front, 19", Top	RP FRT118
1B	Drawer Front, 32", Top	RP FRT35T
2	Drawer Front, 27", Bottom	RP FRT05B
2A	Drawer Front, 19", Bottom	RP FRT119
2B	Drawer Front, 32", Bottom	RP FRT35B
3	Sculptured Handle, 12-13/16"	HD HDL130
4	Dial Thermometer	HD THR9901
5	Mechanical Housing Louver, <b>20048SC &amp; 20072SC only</b>	RP LVR0321
5A	Mechanical Housing Louver, <b>20078SC only</b>	RP LVR0505
5B	Mechanical Housing Louver, <b>20105SC only</b>	RP LVR0322
5C	Mechanical Housing Louver, <b>20048SCF &amp; 20072SCF only</b>	RP LVR0326
5D	Mechanical Housing Louver, <b>20105SCF only</b>	RP LVR0327
5E	Mechanical Housing Louver, <b>20042R only</b>	RP LVR0323
5F	Mechanical Housing Louver, <b>20065R only</b>	RP LVR0324
5G	Mechanical Housing Louver, <b>20092R only</b>	RP LVR0325
5H	Mechanical Housing Louver, <b>20042RF only</b>	RP LVR0506
5I	Mechanical Housing Louver, <b>20065RF only</b>	RP LVR0507
5J	Mechanical Housing Louver, <b>20092RF only</b>	RP LVR0508
6	4 1/2" Heavy Duty Casters w/locking mechanism	HD CST030
6A	4 1/2" Heavy Duty Casters w/out locking mechanism	HD CST031
6B	5 1/2" Heavy Duty Casters w/locking mechanism	HD CST0213
6C	5 1/2" Heavy Duty Casters w/out locking mechanism	HD CST0212
7	Caster Shim Plate (20pc)	RP KIT0412
8	6" Stainless Steel Legs w/adjustable bullet feet	HD LEG9902
9	Mounting Plate for 27" Drawer	RP MPT027
9A	Mounting Plate for 19" Drawer	RP MPT019
9B	Mounting Plate for 32" Drawer	RP MPT032
10	Thumb Screw	HD PIN107
11	Drawer Track, 2pc. Set (Jan 1997-present)	RP TRK05SM
11A	Drawer Track, 1pc. Pin mounted (1993-1997)	RP TRK05P
12	Roller Bearings for Drawer (Jan 1997-present)	HD BRG210
12A	Screw for HD BRG210 draw bearing	FA SCW6002
13	Drawer Frame, 27" Extendable	RP FRM127E
13A	Drawer Frame, 19" Non-extendable	RP FRM019
13B	Drawer Frame, 32" Extendable	RP FRM132E
14	Drawer Gasket, 27" DR. FR. 24.75 X 7.25 PRESS IN	IN GSK1070
14A	Drawer Gasket, 19" DR. FT. 16.75 X 7.25 PRESS IN	IN GSK1081
14B	Drawer Gasket, 32" DR. FT. 29.75 X 7.25 PRESS IN	IN GSK1075
14C	Drawer gasket, 27" DR. FT. 24.75 X 7.25 SCREW IN	IN GSK195
14D	Drawer gasket, 32" DR. FT. 29.75 X 7.25 SCREW IN	IN GSK196
15	Fan Mounting Bracket for Coil Assembly	RP SHD107
16	Mounting Support Bracket for Coil Assembly	RP BRK006
17	Evaporator Fan Motor w/ blade (April 1998 – Present)	EL MTR2338
17A	Evaporator Fan Motor no blade (prior to 4/1998)	EL MTR0230
17B	Evaporator Fan Blade (prior to 4/1998)	RF FAN005
17C	Evaporator Fan Bracket (prior to 4/1998)	RP BRK1050
18	Dial Temperature Control for cooler	HD CNT200
18a	Dial Temperature control for freezer	HD CNT100
19	Evaporator drain pan –Plastic Bottom 18.25 X 4.25 (Ref only)	RP DRP107
19A	Evaporator drain pan – S/S (Freezer only)	RP DRP0201
20	Heating Element for Coil Assembly, Freezer Units only	EL ELM9903
21	TXV Valve for Coil Assembly 134A COOLERS	RF VLV200
21A	TXV Valve for coil assembly 404A FREEZERS	RF VLV404

22	Evaporator Coil	RP COI107
22A	Evaporator Coil Assembly, Refrigerated Units only	RP CSY0401
22B	Evaporator Coil Assembly, Freezer Units only	RP CSY0402
23	Shield Panel for Coil Assembly	RP PNL107
24	Power Cord, Male 9'	EL WIR461
25	Rocker On/Off Switch	EL SWT0502
26	Power Cord, Female 12"	EL WIR469
27	Compressor, 20048SC	RF CMP010-134
27A	Compressor, 20072SC, 20078SC	RF CMP020-134P
27B	Compressor, 20105SC	RF CMP0104P
27C	Compressor, 20048SCF, 20072SCF	RF CMP031P
27D	Compressor, 20105SCF	RF CMP9902P
27E	Compressor, 20105SC-32, 20114SC	RF CMP200-134P
28	Condensing Unit, 20048SC	RF CON0004
28A	Condensing Unit, 20072SC, 20078SC	RF CON0113
28B	Condensing Unit, 20105SC	RF CON0006
28C	Condensing Unit, 20048SCF, 20072SCF	RF CON0003
28D	Condensing Unit, 20105SCF	RF CON9901
28E	Condensing Unit, 20105SC-32, 20114SC	RF CON502
29	Condenser Fan Motor Assy, 20048SC, 20072SC, 20078SC, 20048SCF, 20072SCF	RF ASY0101P
29A	Condenser Fan Motor Assy, 20048SC, 20072SC, 20078SC, 20048SCF, 20072SCF – AFTER Jan 2013	RF ASY1200P
29B	Condenser Fan Motor, 20105SC, 20105SC-32	EL MTR0102
29C	Condenser Fan Motor, 20105SCF	RF MTR0101P
30	Condenser Fan Blade, 20048SC, 20072SC, 20078SC, 20105SC, 20048SCF, 20072SCF	RF BLD0101
30A	Condenser Fan Blade, 20105SCF	RF FAN007
31	Condensing Unit Shroud, 20048SC	RP SHD0505
31A	Condensing Unit Shroud, 20072SC, 20078SC	RP SHD0506
31B	Condensing Unit Shroud, 20105SC	RP SHD0507
31C	Condensing Unit Shroud, 20048SCF, 20072SCF	RP SHD0508
31D	Condensing Unit Shroud, 20105SCF	RP SHD0509
32	Dixell Temperature Control for Rail	RP CNT0207
34	Dixell Mounting Housing Bracket	RP BRK0509
35	Solenoid Valve, Remote Units only 120V.	RF SOL9801
NS	Electric Condensate Heater, 20105SC-32, 20114SC	EL WIR274