

OPERATOR'S MANUAL

This manual provides information on installation, operating, maintenance, trouble shooting & replacement parts for

42000A Refrigerated Wall Mount Display Merchandiser 42036A 42048A 42060A



NOTIFY CARRIER OF DAMAGE AT ONCE.

It is the responsibility of the consignee to inspect the container upon receipt of same and to determine the possibility of any damage, including concealed damage. Randell suggests that if you are suspicious of damage to make a notation on the delivery receipt. It will be the responsibility of the consignee to file a claim with the carrier. We recommend that you do so at once.



525 South Coldwater Road • Weidman, MI 48893
888-994-7636 • Fax 888-864-7636 • unifiedbrands.net

Table of Contents

page 2.....	Congratulations
page 3.....	Parts & Service Hotline
page 3.....	Serial Number Location
page 4-7.....	Randell Limited Warranty
page 8.....	Unit Specifications
page 9-10.....	Unit Installation
page 11-13.....	Unit Operation
page 14-15.....	Preventative Maintenance
page 16.....	Electrical Diagram
page 17.....	Troubleshooting
page 18-21.....	Replacement Parts

Congratulations on your recent purchase of Randell food service equipment, and welcome to the growing family of satisfied Randell customers.

Our reputation for superior products is the result of consistent quality craftsmanship. From the earliest stages of product design to successive steps in fabrication and assembly, rigid standards of excellence are maintained by our staff of designers, engineers, and skilled employees.

Only the finest heavy-duty materials and parts are used in the production of Randell brand equipment. This means that each unit, given proper maintenance will provide years of trouble free service to its owner.

In addition, all Randell food service equipment is backed by some of the best warranties in the food service industry and by our professional staff of service technicians.

Retain this manual for future reference.

NOTICE: Due to a continuous program of product improvement, Randell reserves the right to make changes in design and specifications without prior notice.

NOTICE: Please read the entire manual carefully before installation. If certain recommended procedures are not followed, warranty claims will be denied.

<p>MODEL NUMBER _____</p> <p>SERIAL NUMBER _____</p> <p>INSTALLATION DATE _____</p>
--

The serial number is located on the interior side wall of the display merchandiser.



800-621-8560

**Randell Service and Parts
Hotline**

Warranty Policies

Randell believes strongly in the products it builds and backs them with the best warranty in the industry. Standard with every unit comes the peace of mind that this unit has been thoroughly engineered, properly tested and manufactured to excruciating tolerances, by a manufacturer with over 30 years of industry presence. On top of that front end commitment, Randell has a dedicated staff of certified technicians that monitor our own technical service hotline at **1-800-621-8560** to assist you with any questions or concerns that may arise after delivery of your new Randell equipment.

PARTS WARRANTY

1. One year parts replacement of any and all parts that are found defective in material or workmanship. Randell warrants all component parts of manufactured new equipment to be free of defects in material or workmanship, and that the equipment meets or exceeds reasonable industry standards of performance for a period of one year from the date of shipment from any Randell factory, assembly plant or warehouse facility.

NOTE: warranties are effective from date of shipment, with a thirty day window to allow for shipment, installation and set-up. In the event equipment was shipped to a site other than the final installation site, Randell will warranty for a period of three months following installation, with proof of starting date, up to a maximum of fifteen months from the date of purchase.

2. Free ground freight of customer specified location for all in warranty parts within continental U.S. Component part warranty does not cover glass breakage or gasket replacement. Randell covers all shipping cost related to component part warranty sent at regular ground rates (UPS, USPS). **Freight or postage incurred for any express or specialty methods of shipping are the responsibility of the customer.**

LABOR COVERAGE

In the unlikely event a Randell manufactured unit fails due to defects in materials or workmanship within the first ninety days, Randell agrees to pay the contracted labor rate performed by an **Authorized Service Agent (ASA)**. Any warranty work performed by a non-ASA will not be honored by Randell. A complete listing of current ASAs can be found on the Randell page of our web site : www.unifiedbrands.net. Warranties are effective from date of shipment, with a thirty day window to allow for shipment, installation and setup. Where equipment is shipped to any site other than final installation, Randell will honor the labor warranty for a period of ninety days following installation with proof of starting date, up to a maximum of six months from date of purchase.

Temperature adjustments are not covered under warranty, due to the wide range of ambient conditions.

For warranty inquiries call our Field Service Department at: 1-800-621-8560.

WHEN OPTIONAL 5 YEAR COMPRESSOR WARRANTY APPLIES

1. Provide reimbursement to an ASA for the cost of locally obtained replacement compressor in exchange for the return of the defective compressor sent back freight prepaid. Note: Randell does limit amount of reimbursement allowed and does require bill from local supply house where compressor was obtained (customer should not pay servicing agent up front for compressor).
2. Provide repair at the manufacturing facility by requiring that the defective unit be sent back to Randell freight prepaid. Perform repair at the expense of Randell and ship the item back to the customer freight collect.
3. Furnish complete condensing unit freight collect in exchange for the return of the defective compressor sent back freight prepaid. (Decisions on whether or not to send complete condensing units will be made by Randell's in-house service technician).

WHEN OPTIONAL LABOR EXTENSION POLICY APPLIES

Randell will provide reimbursement of labor to an ASA for any customer that has an optional labor extension of our standard warranty. (Contracted rates do apply) Randell offers both 1 and 2 year extensions. Labor extensions begin at the end of our standard warranty and extend out 9 months to 1 calendar year or 21 months to 2 calendar years from date of purchase. Please contact Randell technical service hotline at 1-800-621-8560 for details and any question on **Authorized Service Agents (ASA)**.

WHEN EXPORT WARRANTIES APPLY

1. Randell covers all non-electrical components under the same guidelines as our standard domestic policy.
2. All electrical components operated on 60 cycle power are covered under our standard domestic policy.
3. All electrical components operated on 50 cycle power are covered for 90 days from shipment only.
4. Extended warranty options are not available from the factory.

ITEMS NOT COVERED UNDER WARRANTY

1. Maintenance type of repairs such as condenser cleaning, temperature adjustments, clogged drains and unit leveling.
2. Randell does not cover gaskets under warranty. Gaskets are a maintenance type component that are subject to daily wear and tear and are the responsibility of the owner of the equipment. Because of the unlimited number of customer related circumstances that can cause gasket failure all gasket replacement issues are considered non-warranty. Randell recommends thorough cleaning of gaskets on a weekly basis with a mild dish soap and warm water. With proper care Randell gaskets can last up to two years, at which time we recommend replacement of all gaskets on the equipment for the best possible performance.

NOTICE: FOOD LOSS IS NOT COVERED UNDER WARRANTY

3. Repairs caused by abuse such as broken glass, freight damage, excessive force, or scratches and dents.
4. Electrical component failure due to water damage from cleaning procedures.

QUOTATIONS

Verbal quotations are provided for customer convenience only and are considered invalid in the absence of a written quotation. Written quotations from Randell are valid for 30 days from quote date unless otherwise specified. Randell assumes no liability for dealer quotations to end-users.

SPECIFICATION & PRODUCT DESIGN

Due to continued product improvement, specification and product design may change without notice. Such revisions do not entitle the buyer to additions. Changes or replacements for previously purchased equipment.

SANITATION REQUIREMENTS

Certain areas require specific annotation requirements other than N.S.F. & U.L. standards. Randell must be advised of these specifications before fabrication of equipment. In these special circumstances, a revised quotation may be required to cover additional costs. Failure to notify Randell before fabrication holds the dealer accountable for all additional charges.

CANCELLATIONS

Orders canceled prior to production scheduling entered into engineering/production and cancelled are subject to a cancellation charge (contact factory for details).

STORAGE CHARGES

Randell makes every effort to consistently meet our customer's shipment expectations. If after the equipment has been fabricated, the customer requests delay in shipment, and warehousing is required:

1. Equipment held for shipment at purchasers request for a period of 30 days beyond original delivery date specified will be invoiced and become immediately payable.
2. Equipment held beyond 30 days after the original delivery date specified will also include storage charges.

SHIPPING & DELIVERY

Randell will attempt to comply with any shipping, routing or carrier request designated by dealer, but reserves the right to ship merchandise via any responsible carrier at the time equipment is ready for shipment. Randell will not be held responsible for any carrier rate differences; rate differences are entirely between the carrier and purchaser. Point of shipping shall be determined by Randell (Weidman, MI/Jackson, MS). At dealer's request, Randell will endeavor whenever practical to meet dealer's request. Freight charges to be collect unless otherwise noted.

DAMAGES

All crating conforms to general motor carrier specifications. To avoid concealed damage, we recommend inspection of every carton upon receipt. In the event the item shows rough handling or visible damage to minimize liability, a full inspection is necessary upon arrival. Appearance of damage will require removing the crate in the presence of the driver. **A notation must be placed on the freight bill and signed for by the truck driver at the time of delivery.** Any and all freight damage that occurs to a Randell piece of equipment as a result of carrier handling is not considered under warranty, and is not covered under warranty guidelines. Any freight damage incurred during shipping needs to have a freight claim filed by the receiver with the shipping carrier. Consignee is responsible for filing of freight claims when a clear delivery receipt is signed. Claims for damages must be filed immediately (within 10 days) by the consignee with the freight carrier and all cartons and merchandise must be retained for inspection.

RETURNED GOODS

Authorization for return must first be obtained from Randell before returning any merchandise. Any returned goods shipment lacking the return authorization number will be refused, all additional freight costs to be borne by the returning party. Returned equipment must be shipped in original carton, freight prepaid and received in good conditions. Any returned merchandise is subject to a minimum handling charge (consult factory for rate).

INSTALLATION

Equipment installation is the responsibility of the dealer and/or their customer. Randell requires all equipment to be professionally installed to ensure adequate voltage and amperage requirements are met.

It is imperative that all casters or legs be in contact with the floor for proper weight distribution. Shimming of casters or legs may be required.

PENALTY CLAUSES

Dealer penalty clauses, on their purchase order or contractually agreed to between the dealer and their clients are not binding on Randell. Randell does not accept orders subject to penalty clauses. This agreement supersedes any such clauses in dealer purchase orders.

EXPORT POLICY

All quotations for export sales will be handled by Dorian Drake International (www.doriandrake.com), Randell's export management organization.

***FOOTNOTES IN REFERENCE TO PARAGRAPHS ABOVE**

1. Herein called Randell.

2. NET means list price less discount, warranty, labor policy, freight, Randell delivery and other miscellaneous charges.

CASH DISCOUNTS WILL BE CALCULATED ON NET ONLY.

Unit Specifications



42048A shown

Model	L	D	H	Storage Cu. Ft.	Shelves Sq. Ft.	HP	Volt	Amps	NEMA	Ship Wt.
42036A	36"	22.5"	20"	4	4	1/4	115/60/1	6.2	5-15P	235
42048A	48"	22.5"	20"	5.6	5.5	1/4	115/60/1	6.2	5-15P	275
42060A	60"	22.5"	20"	6.9	7	1/4	115/60/1	6.2	5-15P	360

Unit Installation

SELECTING A LOCATION FOR YOUR NEW UNIT

The following conditions should be considered when selecting a location for your unit:

1. **Wall Load:** The area on which the unit will rest must be level, free of vibration, and suitably strong enough to support the combined weights of the unit plus the maximum product load weight.
2. **Clearance:** A minimum of 6" clearance above and immediately below the display merchandiser is required. Do not insert the display merchandiser into cabinetry or any confined area.
3. **Ventilation:** The air cooled self contained unit requires a sufficient amount of cool clean air. Avoid surrounding your display merchandiser around other heat generating equipment and out of direct sunlight. Also, avoid locating in an unheated room or where the room temperature may drop below 55° F or above 86°F.

INSTALLATION CHECKLIST

After the final location has been determined, refer to the following checklist prior to start-up:

1. Check cord and plug of unit to assure no damage has occurred to these components.
2. Check all sheet metal surrounding the mechanical compartment to assure no damage has occurred in these areas.
3. Inspect glass doors for proper opening and closing motion.
4. Identify wall that is strong enough to support combined weight of display merchandiser plus product.
5. Attach wall mounting bracket securely to studs within the wall. The wall mount bracket is shipped attached to the unit mounting bracket on the rear of the unit via nylon ties. Cut ties to remove wall mount bracket from unit mounting bracket.



Unit Installation – con't.

6. Carefully lift unit and lower unit onto the wall mounting bracket making sure the unit mounting bracket is securely in the wall mount bracket.
7. Assure unit is level. Shimming may be required so unit is tilting at top or bottom.
8. Plug in unit to appropriate power supply.
9. Allow unit time to cool down to temperature. Typical operating temperatures are 34 °F to 41 °F.
10. Refer to the front of this manual for serial number location. Please record this information in your manual on page 3 now. It will be necessary when ordering replacement parts or requesting warranty service.
11. Confirm that the unit is holding temperature. Set control to desired temperature for your particular ambient and altitude.

NOTE: FAILURE TO FOLLOW INSTALLATION GUIDELINES AND RECOMMENDATIONS MAY VOID THE WARRANTY ON YOUR UNIT.

ELECTRICAL SUPPLY: The wiring should be done by a qualified electrician in accordance with local electrical codes. A properly wired and grounded outlet will assure proper operation. Please consult the data tag attached to the compressor to ascertain the correct electrical requirements. Supply voltage and amperage requirements are located on the serial number tag located inside the mechanical housing.

NOTE: it is important that your unit has its own dedicated line. Condensing units are designed to operate with a voltage fluctuation of plus or minus 10% of the voltage indicated on the unit data tag. Burn out of a condensing unit due to exceeding voltage limits will void the warranty.

Unit Operation

Randell has preset the cold control to ensure that your unit runs at an optimum temperature, but due to varying ambient conditions, including elevation, food product as well as type of operation, you may need to alter this temperature. Additional adjustments can be made (within limits) by turning the control dial up or down until the desired temperature is reached. Please allow 24 hours between adjustments.

Do not leave doors open for prolonged periods of time. This is especially important in the summer months and in kitchens exceeding 86° F.

Note: Product entering the display merchandiser must be at 41°F or less.

Your 42000A series display merchandiser is equipped with a temperature adjustment control for the refrigerated rail (Figure 1). This is found behind the mirror on the interior real wall.



Figure 1 illustrates the evaporator fan shroud assembly. The thermostat adjustment knob for the display merchandiser is located on the top right of the evaporator fan shroud. Access to this area can be obtained by removing the doors, shelving, and mirror.

To adjust the temperature:

A. To lower the temperature:

1. Turn the dial knob clockwise.
2. There are numbers to indicate settings. Keep the arrow on the knob pointed within the numbered section of the arc.
3. Turning it clockwise beyond the numbered section can result in freeze-up.

B. To raise the temperature:

1. Turn the dial knob counterclockwise.
2. There are numbers to indicate settings. Keep the arrow on the knob pointed within the numbered section of the arc.
3. Turning it counterclockwise beyond the numbered section will shut the compressor off.

NOTE: It is not recommended to turn the dial above 8 or below 1 on the temperature control. If the adjustments still do not result in proper temperature please contact the factory at 1-800-621-8560 or call the factory ASA.

Unit Operation – con't.

Door Removal:

1. Locate outside door (sticker to identify door in lower corner of door)
2. Open door 3"
3. Lift door up
4. Pull lower part of door out away from unit.
5. Repeat for inside door



Door Installation:

1. Locate inside door (sticker to identify door in lower corner of door)
2. Place black spring closure tab at rear top of door.
3. Pick up on door
4. Insert lower part of door in to track when door is 3" open
5. Assure door spring forces door closed
6. Repeat for outside door.



Unit Operation – con't.

Door Adjustment:

Roller bearings on bottom of each door may be adjusted to allow for proper seal of glass door. To look for proper door sealing assure that the bumper gasket of each door touches the entire vertical side of the door frame. No gaps should be visible



NOTE: The design of the bumper gasket does allow for a small 1/8" gap at top of each door.

SERVICE CONNECTIONS:

High and low side refrigeration service connections are in compressor area in rear of unit. Any repairs to the sealed refrigeration system should be performed by an ASA or licensed refrigeration technician.

Preventive Maintenance

Randell strongly suggests a preventive maintenance program which would include the following **Monthly** procedures:

If a failure of the equipment is a direct result of any of the Preventative Maintenance guidelines being neglected the repairs will not be covered under warranty.

1. Cleaning of all condenser coils. Condenser coils are a critical component in the life of the compressor and must remain clean to assure proper air flow and heat transfer. Failure to maintain this heat transfer will affect unit performance and eventually destroy the compressor. Clean the condenser coils with coil cleaner and/or a vacuum, cleaner and brush.

NOTE: Cleaning of condenser coil will require unit to be removed from the wall. Take precaution when removing unit from wall.

1A. Use of any filter over the condenser coil may result in poor performance of the equipment. The factory does not recommend any auxiliary filter be used on the condenser coil. Any failures of the unit as a result of an auxiliary filter will not be covered under warranty.

NOTE: Brush coil in direction of fins, normally vertically as to not damage or restrict air from passing through condenser.

2. Clean fan blade on the condensing unit.

3. Clean all debris under glass doors in the track area.

NOTE: DO NOT USE SHARP UTENSILS.

RECOMMENDED CLEANERS FOR YOUR STAINLESS STEEL INCLUDE THE FOLLOWING:

JOB	CLEANING AGENT	COMMENTS
Routine cleaning	Soap, ammonia, detergent Medallion	Apply with a sponge or cloth
Fingerprints and smears	Arcal 20, Lac-O-Nu, Ecoshine	Provides a barrier film
Stubborn stains and discoloration	Cameo, Talc, Zud, First Impression	Rub in the direction of the polish lines
Greasy and fatty acids, blood, burnt-on foods	Easy-Off, Degrease It, Oven Aid	Excellent removal on all finishes
Grease and Oil	Any good commercial detergent	Apply with a sponge or cloth
Restoration/Preservation	Benefit, Super Sheen	Good idea monthly

Reference: Nickel Development Institute, Diversey Lever, Savin, Ecolab, NAFEM.

NOTE: Do not use steel pads, wire brushes, scrapers, or chloride cleaners to clean your stainless steel.

CAUTION: DO NOT USE ABRASIVE CLEANING SOLVENTS, AND NEVER USE HYDROCHLORIC ACID (MURIATIC ACID) ON STAINLESS STEEL.

Preventive Maintenance (cont.)

Proper maintenance of equipment is the ultimate necessity in preventing costly repairs. By evaluating each unit on a regular schedule, you can often catch and repair minor problems before they completely disable the unit and become burdensome on your entire operation.

For more information on preventive maintenance, consult the local ASA or CFESA member. Most repair companies offer this service at very reasonable rates to allow you the time you need to run your business along with the peace of mind that all your equipment will last throughout its expected life. These services often offer guarantees as well as the flexibility in scheduling or maintenance for your convenience.

For a complete listing of current Randell ASA please visit www.unifiedbrands.net

Randell believes strongly in the products it manufactures and backs those products with one of the best warranties in the industry. We believe with the proper maintenance and use, you will realize a profitable return on your investment and years of satisfied service.

Electrical Diagram

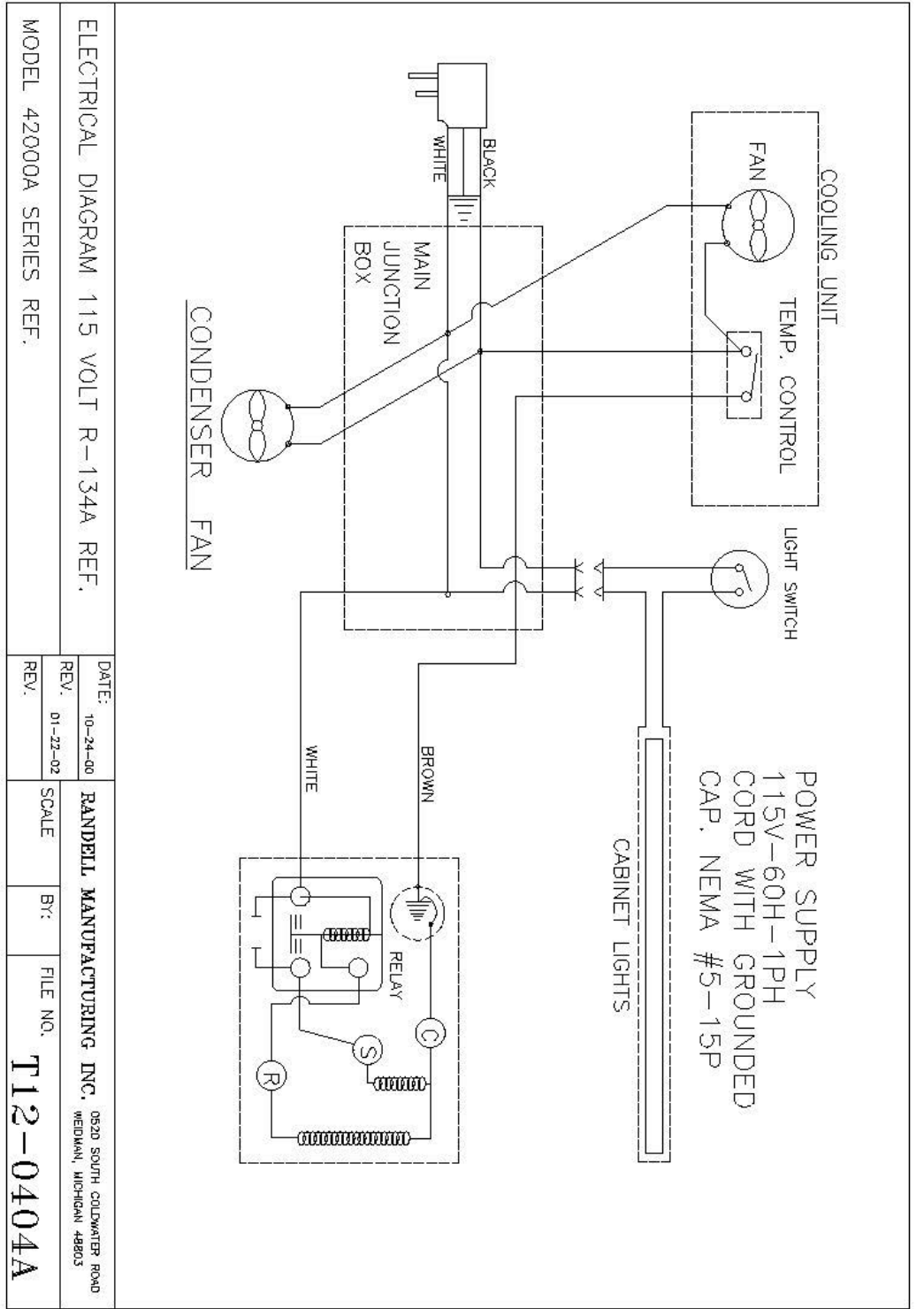

Trouble Shooting Guide

SYMPTOM	POSSIBLE CAUSE	PROCEDURE
Unit doesn't run	<ol style="list-style-type: none"> 1. No power to unit 2. Temperature control turned off 3. Temperature control faulty 4. Compressor overheated 5. Condenser fan faulty 6. Overload protector faulty 7. Compressor relay faulty 8. Compressor faulty 	<ol style="list-style-type: none"> 1. Plug in unit 2. Check temperature control 3. Test temperature control 4. Clean condenser coil 5. Service condenser fan 6. Test overload 7. Test relay 8. Call ASA for service
Unit short cycles	<ol style="list-style-type: none"> 1. Condenser coil dirty 2. Condenser fan faulty 3. Compressor faulty 4. Overload repeatedly tripping 	<ol style="list-style-type: none"> 1. Clean coil 2. Service fan and motor. 3. Call ASA for service 4. Check outlet voltage
Unit runs constantly	<ol style="list-style-type: none"> 1. Frost build-up 2. Door not sealing properly 3. Door not closing 4. Door gasket damaged 5. Condenser coil dirty 6. Condenser fan faulty 7. Refrigerant leak 	<ol style="list-style-type: none"> 1. Defrost evaporator 2. Check door seal & roller bearing 3. Check door spring 4. Replace door gasket 5. Clean coil 6. Service condenser motor 7. Call ASA for service
Unit not cold enough	<ol style="list-style-type: none"> 1. Temperature control set too high 2. Temperature control faulty 3. Condenser coil dirty 4. Door not sealing properly 5. Door gasket damaged 6. Evaporator fan faulty 7. Evaporator iced up 8. Refrigerant leaking 	<ol style="list-style-type: none"> 1. Adjust control to lower setting 2. Test control 3. Clean coil 4. Check door seal 5. Replace door gasket 6. Service evaporator fan 7. Door not sealing 8. Call ASA for service
Unit too cold	<ol style="list-style-type: none"> 1. Temperature control set too low 2. Temperature control faulty 	<ol style="list-style-type: none"> 1. Adjust control to raise setting 2. Test control
Ice in drain pan or water in bottom of unit or floor	<ol style="list-style-type: none"> 1. Drain tube clogged 2. Unit not level 	<ol style="list-style-type: none"> 1. Clean drain 2. Level unit
Unit noisy	<ol style="list-style-type: none"> 1. Unit not level 2. Compressor mountings loose or hardened. 3. Condenser fan damaged or hitting fan shroud 4. Evaporator fan damaged or hitting fan shroud 	<ol style="list-style-type: none"> 1. Adjust leveling leg/shim casters 2. Tighten or replace compressor mountings 3. Inspect condenser fan 4. Inspect evaporator fan

Replacement Parts

42000A Series

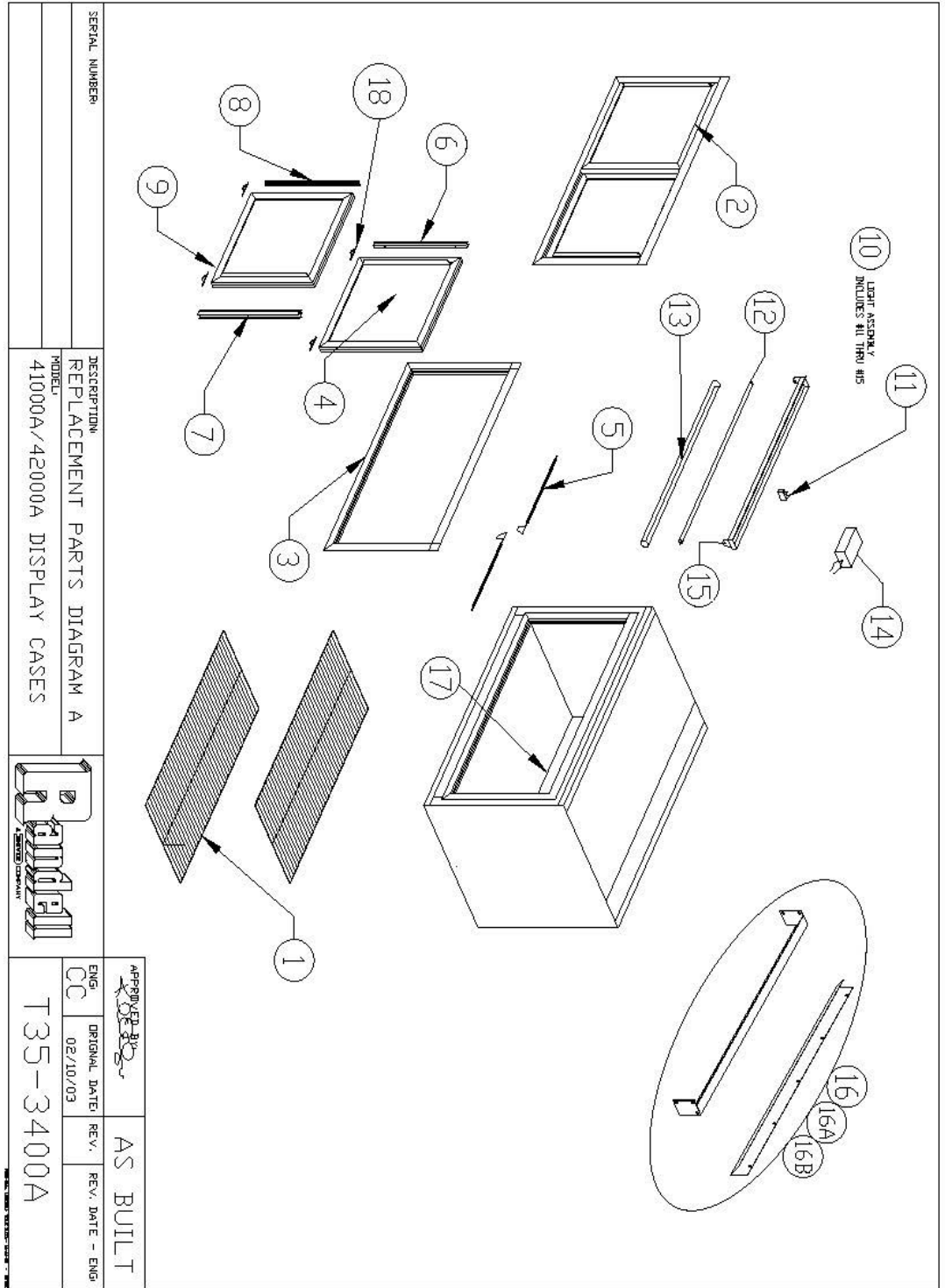

SERIAL NUMBER	DESCRIPTION	APPROVED BY	AS BUILT
	REPLACEMENT PARTS DIAGRAM A	<i>[Signature]</i>	
MODEL	41000A/42000A DISPLAY CASES	ENG. CC	ORIGINAL DATE: 02/10/03
			REV. DATE - ENG.
			T35-3400A

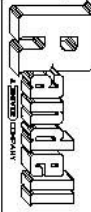

Replacement Parts

42000A Series

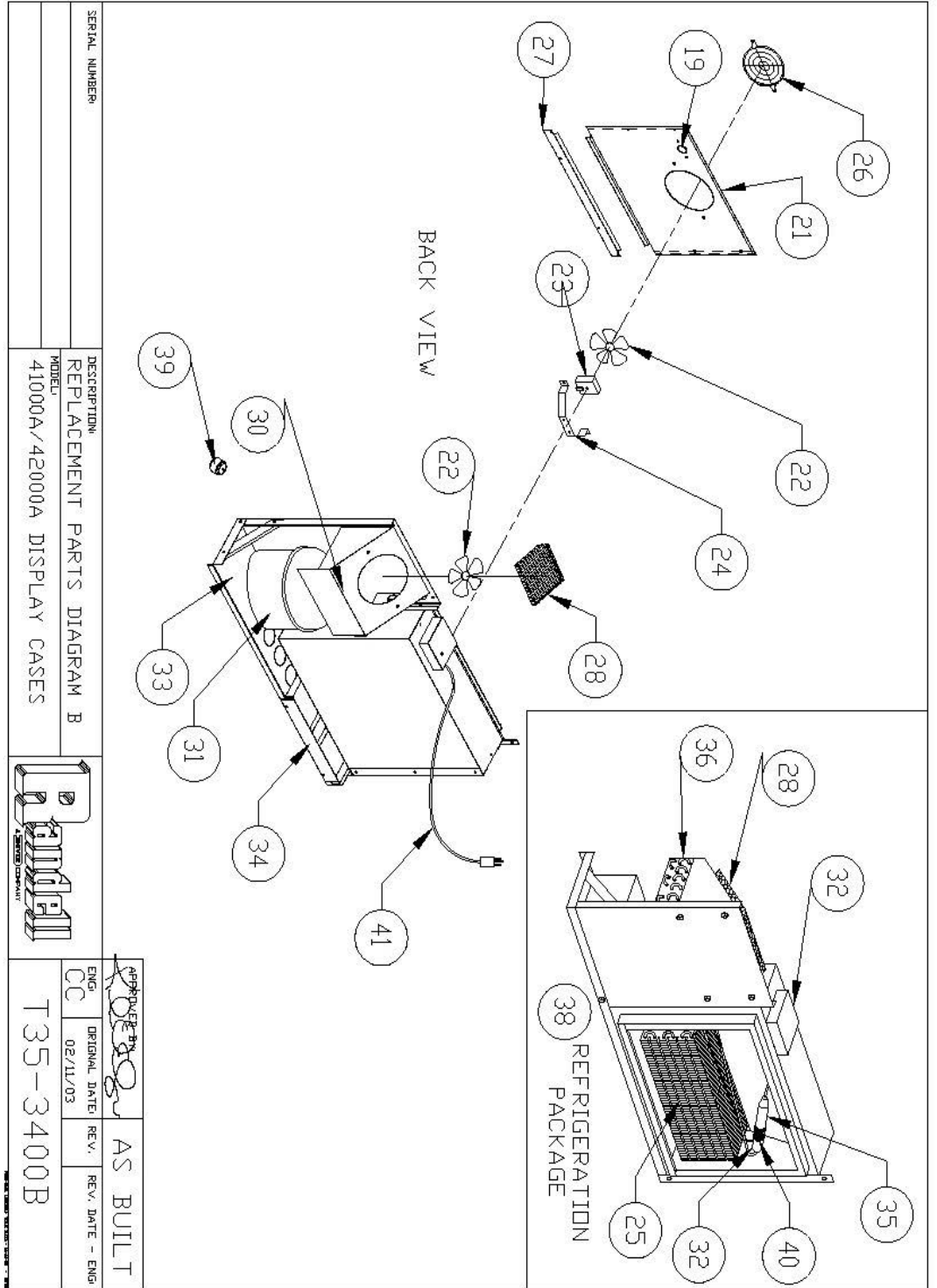

Replacement Parts List

42000A Series

Item #	Part #	Description	42036A	42048A	42060A
1	HD SHL005	SHELF 8 1/2" X 31 7/8"	X		
1A	HD SHL006	SHELF 8 1/2" X 43 7/8"		X	
1B	HD SHL007	SHELF 8 1/2" X 55 7/8"			X
2	HD FRM036	FRAME & DOOR ASSY 17" X 31 7/8"	X		
2A	HD FRM048	FRAME & DOOR ASSY 17" X 43 7/8"		X	
2B	HD FRM060	FRAME & DOOR ASSY 17" X 55 7/8"			X
3	HD FRM036F	FRAME ONLY 17" X 31 7/8"	X		
3A	HD FRM048F	FRAME ONLY 17" X 43 7/8"		X	
3B	HD FRM060F	FRAME ONLY 17" X 55 7/8"			X
4	HD FRM036DL	LEFT HAND DOOR	X		
4A	HD FRM048DL	LEFT HAND DOOR		X	
4B	HD FRM060DL	LEFT HAND DOOR			X
5	HD SPR036	DOOR SPRING 12"	X		
5A	HD SPR048	DOOR SPRING 19"		X	
5B	HD SPR060	DOOR SPRING 23"			X
6	IN GSK902	LEFT HAND BUMPER	X	X	X
7	IN GSK901	RIGHT HAND BUMPER	X	X	X
8	IN GSK900	WIPER GASKET	X	X	X
9	HD FRM036DR	RIGHT HAND DOOR	X		
9A	HD FRM048DR	RIGHT HAND DOOR		X	
9B	HD FRM060DR	RIGHT HAND DOOR			X
10	RP LGT0102	LIGHT FIXTURE COMPLETE	X		
10A	RP LGT0103	LIGHT FIXTURE COMPLETE		X	X
11	EL SWT0502	LIGHT SWITCH	X	X	X
12	EL TUB9801	LAMP, 36", FLOR., F17T8TL741	X		
12A	EL TUB100	LAMP, FLORESCENT F30T8CW		X	X
13	EL SHD600	LAMP SHIELD / T12 BULB	X		
13-1	EL SHD600A	LAMP SHIELD END CAPS / T12 BULB	X		
13A	EL SHD018	LAMP SHIELD / T8 BULB		X	X
13A-1	EL SHD018A	LAMP SHIELD END CAPS / T8 BULB		X	X
14	EL BLS100	BALLAST SS2P	X		
14A	EL BLS400	BALLAST SS40BP		X	X
15	EL LGT414	BULB HOLDERS	X	X	X
16	RP MNT036	WALL MOUNT KIT	X		
16A	RP MNT048	WALL MOUNT KIT		X	
16B	RP MNT060	WALL MOUNT KIT			X
17	RP MIR42036	MIRROR W/ TRIM, 13" X 30 7/8"	X		
17A	RP MIR42028	MIRROR W/ TRIM, 13" X 42 7/8"		X	
17B	RP MIR42060	MIRROR W/ TRIM, 13" X 54 7/8"			X
18	HD ASY0501	GLASS DOOR ROLLER BEARING	X	X	X
19	HD CNT200	COLD CONTROL	X	X	X
20	HD THR100	4" HANGING THERMOMETER	X	X	X
21	RP SHD0302	EVAP FAN SHROUD	X	X	X

Item #	Part #	Description	42036A	42048A	42060A
22	RF FAN005	FAN BLADE	X	X	X
23	EL MTR0230	EVAP FAN MOTOR	X	X	X
24	RP BRK1050	MOTOR MOUNT BRACKET	X	X	X
25	RF COI120B	EVAP COIL	X	X	X
26	RF FAN010	FAN GUARD	X	X	X
27	RP DFL0801	EVAP HOUSING AIR DEFLECTOR	X	X	X
28	RP GRD0801	COND FAN GUARD - SCREEN	X	X	X
30	RP HSG0802	COND FAN HOUSING	X	X	X
31	RF CMP010-134	AEA4430YXA COMPRESSOR	X	X	X
32	RP CVR0804	J-BOX POWER SUPPLY COVER	X	X	X
33	RP PAN0302	CONDENSER BASE 42000	X	X	X
34	RP PAN0302	COND PAN SM	X	X	X
35	RF ACM005	3/8" ACCUMULATOR	X	X	X
36	RF COI030	COND COIL 3 X 6 X 9	X	X	X
38	RP 4046001	REFRIGERATION PACKAGE ASSY	X	X	X
39	RF FLT9902	FILTER DRIER, 1/4" DBL INLET, .042"	X	X	X
40	RP CAP001	CAP TUBE W/ DRIER, .042" ID X 96"	X	X	X
41	EL WIR461-90	POWER CORD, 16/3 9'	X	X	X