

OPERATOR'S MANUAL

This manual provides information on installation, operating, maintenance, trouble shooting & replacement parts for

OPEN DISPLAY CASE SSAC-40BSC



NOTIFY CARRIER OF DAMAGE AT ONCE.

It is the responsibility of the consignee to inspect the container upon receipt of same and to determine the possibility of any damage, including concealed damage. Randell suggests that if you are suspicious of damage to make a notation on the delivery receipt. It will be the responsibility of the consignee to file a claim with the carrier. We recommend that you do so at once.

Information contained in this document is known to be current and accurate at the time of printing/creation. Unified Brands recommends referencing our product line websites, unifiedbrands.net, for the most updated product information and specifications.



Randell Manufacturing

Unified Brands, Inc

**525 South Coldwater Rd • Weidman, MI 48893
888-994-7636 • Fax 888-864-7636 • unifiedbrands.net**

Table of Contents

page 2.....Congratulations
page 3.....Parts & Service Hotline
page 3.....Serial Number Location
page 4-7.....Randell Limited Warranty
page 8.....Unit Specifications
page 9-10.....Unit Installation
page 11-12.....Unit Operation
page 13-14.....Control Settings and Instructions
page 15-16.....Preventive Maintenance
page 17.....Electrical Diagram
page 18.....Troubleshooting
page 19-22.....Replacement Parts

Congratulations on your recent purchase of Randell food service equipment, and welcome to the growing family of satisfied Randell customers.

Our reputation for superior products is the result of consistent quality craftsmanship. From the earliest stages of product design to successive steps in fabrication and assembly, rigid standards of excellence are maintained by our staff of designers, engineers, and skilled employees.

Only the finest heavy-duty materials and parts are used in the production of Randell brand equipment. This means that each unit, given proper maintenance will provide years of trouble free service to its owner.

In addition, all Randell food service equipment is backed by some of the best warranties in the food service industry and by our professional staff of service technicians.

Retain this manual for future reference.

NOTICE: Due to a continuous program of product improvement, Randell Manufacturing reserves the right to make changes in design and specifications without prior notice.

NOTICE: Please read the entire manual carefully before installation. If certain recommended procedures are not followed, warranty claims will be denied.

<p>MODEL NUMBER _____</p> <p>SERIAL NUMBER _____</p> <p>INSTALLATION DATE _____</p>
--

The serial number is located in the mechanical housing.

800-621-8560

**Randell Manufacturing Service
and Parts Hotline**

Warranty Policies

Congratulations on your purchase of a Randell Manufactured piece of equipment. Randell believes strongly in the products it builds and backs them with the best warranty in the industry. Standard with every unit comes the peace of mind that this unit has been thoroughly engineered, properly tested and manufactured to excruciating tolerances, by a manufacturer with over 25 years of industry presence. On top of that front end commitment, Randell has a dedicated staff of certified technicians that monitor our own technical service hotline at **1-800-621-8560** to assist you with any questions or concerns that may arise after delivery of your new Randell equipment.

PARTS WARRANTY

1. One year parts replacement of any and all parts that are found defective in material or workmanship. Randell warrants all component parts of manufactured new equipment to be free of defects in material or workmanship, and that the equipment meets or exceeds reasonable industry standards of performance for a period of one year from the date of shipment from any Randell factory, assembly plant or warehouse facility.

NOTE: warranties are effective from date of shipment, with a thirty day window to allow for shipment, installation and set-up. In the event equipment was shipped to a site other than the final installation site, Randell will warranty for a period of three months following installation, with proof of starting date, up to a maximum of eighteen months from the date of purchase.

2. Free ground freight of customer specified location for all in warranty parts within continental U.S. Component part warranty does not cover glass breakage or gasket replacement. Randell covers all shipping cost related to component part warranty sent at regular ground rates (UPS, USPS). **Freight or postage incurred for any express or specialty methods of shipping are the responsibility of the customer.**

LABOR COVERAGE

In the unlikely event a Randell manufactured unit fails due to defects in materials or workmanship within the first ninety days, Randell agrees to pay reasonable labor incurred. During the first ninety days, work authorizations are not required for in warranty repairs. However, repair times are limited to certain flex rate schedules and hours will be deducted from service invoices if they exceed allowed times without prior approval and a work authorization number. Warranties are effective from date of shipment, with a thirty day window to allow for shipment, installation and setup. Where equipment is shipped to any site other than final installation, Randell will honor the labor

warranty for a period of ninety days following installation with proof of starting date, up to a maximum of nine months from date of purchase. Travel time is limited to one hour each direction or two hours per invoice. **Any travel time exceeding two hours will be the responsibility of the customer.**

Temperature adjustments are not covered under warranty, due to the wide range of ambient conditions.

To request a warranty approval number, call our Field Service Department at: 1-800-621-8560

WHEN OPTIONAL 5 YEAR COMPRESSOR WARRANTY APPLIES

1. Provide reimbursement to servicing company for the cost of locally obtained replacement compressor in exchange for the return of the defective compressor sent back freight prepaid. Note: Randell Manufacturing does limit amount of reimbursement allowed and does require bill from local supply house where compressor was obtained (customer should not pay servicing agent up front for compressor).
2. Provide repair at the manufacturing facility by requiring that the defective unit be sent back to Randell freight prepaid. Perform repair at the expense of Randell and ship the item back to the customer freight collect.
3. Furnish complete condensing unit freight collect in exchange for the return of the defective compressor sent back freight prepaid. (Decisions on whether or not to send complete condensing units will be made by Randell's in-house service technician).

WHEN OPTIONAL LABOR EXTENSION POLICY APPLIES

Randell Manufacturing will provide reimbursement of labor invoiced to any customer that has an optional labor extension of our standard warranty. (Reasonable geographic and industry rates do apply) Randell offers both 1 and 2 year extensions. Labor extensions begin at the end of our standard warranty and extend out 9 months to 1 calendar year or 21 months to 2 calendar years from date of purchase. Please contact Randell Manufacturing's technical service hotline at 1-800-621-8560 for details and warranty authorization numbers.

WHEN EXPORT WARRANTIES APPLY

1. Randell Manufacturing covers all non-electrical components under the same guidelines as our standard domestic policy.
2. All electrical components operated on 60 cycle power are covered under our standard domestic policy.
3. All electrical components operated on 50 cycle power are covered for 90 days from shipment only.
4. Extended warranty options are not available from the factory.

ITEMS NOT COVERED UNDER WARRANTY

1. Maintenance type of repairs such as condenser cleaning, temperature adjustments, clogged drains and unit leveling.
2. Randell does not cover gaskets under warranty. Gaskets are a maintenance type component that are subject to daily wear and tear and are the responsibility of the owner of the equipment. Because of

the unlimited number of customer related circumstances that can cause gasket failure all gasket replacement issues are considered non-warranty. Randell recommends thorough cleaning of gaskets on a weekly basis with a mild dish soap and warm water. With proper care Randell gaskets can last up to two years, at which time we recommend replacement of all gaskets on the equipment for the best possible performance.

NOTICE: FOOD LOSS IS NOT COVERED UNDER WARRANTY

3. Repairs caused by abuse such as broken glass, freight damage, or scratches and dents.
4. Electrical component failure due to water damage from cleaning procedures.

QUOTATIONS

Verbal quotations are provided for customer convenience only and are considered invalid in the absence of a written quotation. Written quotations from Randell are valid for 30 days from quote date unless otherwise specified. Randell assumes no liability for dealer quotations to end-users.

SPECIFICATION & PRODUCT DESIGN

Due to continued product improvement, specification and product design may change without notice. Such revisions do not entitle the buyer to additions. Changes or replacements for previously purchased equipment.

SANITATION REQUIREMENTS

Certain areas require specific annotation requirements other than N.S.F. & U.L. standards. Randell must be advised of these specifications before fabrication of equipment. In these special circumstances, a revised quotation may be required to cover additional costs. Failure to notify Randell before fabrication holds the dealer accountable for all additional charges.

CANCELLATIONS

Orders canceled prior to production scheduling entered into engineering/production and cancelled are subject to a cancellation charge (contact factory for details).

STORAGE CHARGES

Randell makes every effort to consistently meet our customer's shipment expectations. If after the equipment has been fabricated, the customer requests delay in shipment, and warehousing is required:

1. Equipment held for shipment at purchasers request for a period of 30 days beyond original delivery date specified will be invoiced and become immediately payable.
2. Equipment held beyond 30 days after the original delivery date specified will also include storage charges.

SHIPPING & DELIVERY

Randell will attempt to comply with any shipping, routing or carrier request designated by dealer, but reserves the right to ship merchandise via any responsible carrier at the time equipment is ready for shipment. Randell will

not be held responsible for any carrier rate differences; rate differences are entirely between the carrier and purchaser. Point of shipping shall be determined by Randell (Weidman, MI/Tucson, AZ). At dealer's request, Randell will endeavor whenever practical to meet dealer's request. Freight charges to be collect unless otherwise noted.

DAMAGES

All crating conforms to general motor carrier specifications. To avoid concealed damage, we recommend inspection of every carton upon receipt. In the event the item shows rough handling or visible damage to minimize liability, a full inspection is necessary upon arrival. Appearance of damage will require removing the crate in the presence of the driver. **A notation must be placed on the freight bill and signed for by the truck driver at the time of delivery.** Any and all freight damage that occurs to a Randell piece of equipment as a result of carrier handling is not considered under warranty, and is not covered under warranty guidelines. Any freight damage incurred during shipping needs to have a freight claim filed by the receiver with the shipping carrier. Consignee is responsible for filing of freight claims when a clear delivery receipt is signed. Claims for damages must be filed immediately (within 10 days) by the consignee with the freight carrier and all cartons and merchandise must be retained for inspection.

RETURNED GOODS

Authorization for return must first be obtained from Randell before returning any merchandise. Any returned goods shipment lacking the return authorization number will be refused, all additional freight costs to be borne by the returning party. Returned equipment must be shipped in original carton, freight prepaid and received in good conditions. Any returned merchandise is subject to a minimum handling charge (consult factory for rate).

INSTALLATION

Equipment installation is the responsibility of the dealer and/or their customer. Randell requires all equipment to be professionally installed.

PENALTY CLAUSES

Dealer penalty clauses, on their purchase order or contractually agreed to between the dealer and their clients are not binding on Randell. Randell does not accept orders subject to penalty clauses. This agreement supersedes any such clauses in dealer purchase orders.

EXPORT POLICY

All quotations for export sales will be handled by Dorian Drake International (www.doriandrake.com), Randell's export management organization.

***FOOTNOTES IN REFERENCE TO PARAGRAPHS ABOVE**

1. Herein called Randell.
2. NET means list price less discount, warranty, labor policy, freight, Randell delivery and other miscellaneous charges.

CASH DISCOUNTS WILL BE CALCULATED ON NET ONLY.

Unit Specifications

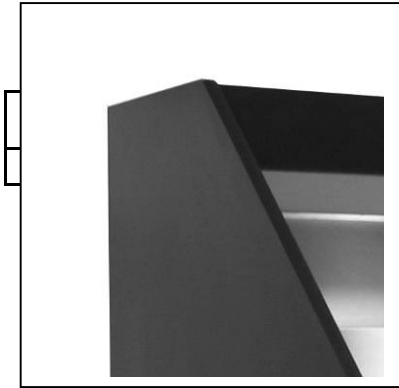

H.P.	Voltage	Amps	Ref / Qty	NEMA	Ship Wt.
3/8	115/60/1	8.6	R134a / 20oz	5-15P	

Unit Installation

SELECTING A LOCATION FOR YOUR NEW UNIT

The following conditions should be considered when selecting a location for your unit:

1. **Floor Load:** The area on which the unit will rest must be level, free of vibration, and suitably strong enough to support the combined weights of the unit plus the maximum product load weight
2. **Clearance:** A clearance of 2" behind the unit is recommended to assure adequate ventilation for the refrigeration system.
3. **Ventilation:** The air cooled self contained unit requires a sufficient amount of cool clean air. Avoid surrounding your equipment stand around other heat generating equipment and out of direct sunlight. Also, avoid locating in an unheated room or where the room temperature may drop below 55° F or about 90° F.

INSTALLATION CHECKLIST

After the final location has been determined, refer to the following checklist prior to start-up:

1. Check all exposed refrigeration lines to ensure that they are not kinked, dented, or rubbing together.
2. Check that the condenser and evaporator fans rotate freely without striking any stationary members.
3. Unit must be properly leveled; check all legs or casters to ensure they all are in contact with the floor while maintaining a level work surface. Adjusting bullet feet heights or shiming casters may be necessary if the floor is not level. **NOTE: Damage to equipment may result if not followed. Randell is not responsible for damage to equipment if improperly installed.**
4. Plug in unit and turn on main on/off power switch. The main power switch is located in the ceiling of the display area inside the light fixture. (Note: This switch turns operates the light *and* the refrigeration system.)
5. Allow unit time to cool down to temperature. If temperature adjustments are required, the temperature control is located within the cabinet base behind the front louver panel. Confirm that the unit is holding the desired temperature.
6. Refer to the front of this manual for serial number location. Please record this information in your manual on page 3 now. It will be necessary when ordering replacement parts or requesting warranty service.
7. Before putting in food, allow your unit to operate for approximately 1 hour so that interior of the unit is cooled down to storage temperature.

NOTE: All motors are oiled and sealed.

NOTE: FAILURE TO FOLLOW INSTALLATION GUIDELINES AND RECOMMENDATIONS MAY VOID THE WARRANTY ON YOUR UNIT.

ELECTRICAL SUPPLY: Any wiring should be done by a qualified electrician in accordance with local electrical codes. A properly wired and grounded outlet will assure proper operation. Please consult the data tag attached to the compressor to ascertain the correct electrical requirements. Supply voltage and amperage requirements are located on the serial number tag located inside the mechanical housing.

NOTE: It is important that a voltage reading be made at the compressor motor electrical connections, while the unit is in operation to verify the correct voltage required by the compressor is being supplied. Low or high voltage can detrimentally affect operation and thereby void its warranty.

NOTE: it is important that your unit has its own dedicated line. Condensing units are designed to operate with a voltage fluctuation of plus or minus 10% of the voltage indicated on the unit data tag. Burn out of a condensing unit due to exceeding voltage limits will void the warranty.

Unit Operation

PRODUCT PLACEMENT AND MAXIMUM LOAD LEVELS

1. This unit and the shelving provided, is designed for displaying of packaged products in containers approximately 4" in height.
2. It is designed so that there is air flow over and between the containers to protect food products from warmer ambient temperatures.
3. Packages should never be located or stacked so that they are higher than 2" *below* the sides or Plexiglas front shield. An over-filled unit will be inefficient and cause poor cooling performance.
4. This unit is designed for *holding* products at 33F to 41F. Products placed in unit should be pre-chilled to the holding temperature. This unit is not intended for use as a *pull down* cabinet.
5. This unit will operate most efficiently when 50% to 90% full. It is best to provide a small amount of space between containers to allow air to flow between them. This will also assure that you are maintaining the best possible temperature in every package.

AMBIENT CONDITIONS

1. This unit is designed for operation in a room ambient of 75F / 55% relative humidity. It should only be used in air conditioned spaces. It should never be used outside or located in direct sunlight.
2. The display area should be protected from excessive room air flow. Locate the unit away from air ducts that might blow directly into the display area. If necessary, have air diverting devices added to your ventilation system to direct air away from the display area. Failure to correct excessive room air flow issues will result in poor temperature performance in the display area.

Randell has attempted to preset the temperature control to ensure that your unit runs at an optimum temperature, but due to varying ambient conditions, including elevation, food type and your type of operation, you may need to alter this temperature.



Your display case is equipped with an electronic temperature. Figure one, left, illustrates the control location behind the front louvered panel. The control type with "fnc" button is shown.

Before making temperature adjustments:

- A. Make sure that you are allowing adequate time for the cabinet temperature to equalize. When initially started or when first loaded, it can take a long time for temperatures in the display area to stabilize.
- B. Make sure that unit operation is not being effected by room ambient conditions. (See Ambient Conditions section above). If there are any significant ambient issues, adjusting the temperature setting may not help.

To raise temperature:

- A. Push and hold the “set” button until set point 33 appears then release the “set” button. 33 is the current set point temperature.
- B. Push and release the up arrow 2 times until 35 is displayed. Push and release the “set” button one time. The new set point, 35, will flash 3 times and then will be locked in.

To lower temperature:

- A. Push and hold the “set” button until 33 appears and then release the “set” button. 33 is the current set point temperature.
- B. Push and release the up arrow 1 time until 32 is displayed. Push and release the “set” button one time. The new set point, 32, will flash 3 times and then will be locked in.

If your temperature control is a type with “fnc” button, follow these instructions:

To raise temperature:

- A. Push and quickly release the “set” button. “SEt” should appear. Press and release the “set” button again. 34 should appear. 34 is the current set point temperature.
- B. Press the “^” button (up arrow) 2 times until 36 is displayed. Press the “set” button again to enter the change. Press the “fnc” button to return to regular temperature display.

To lower temperature:

- A. Push and quickly release the “set” button. “SEt” should appear. Press and release “set” button again. 34 should appear. 34 is the current set point temperature.
- B. Press the “v” button (down arrow) 2 times until 32 is displayed. Press the “set” button again to enter the change. Press the “fnc” button to return to regular temperature display.

NOTE: It is recommended to only make changes of 1 Or 2 degree increments at a time. Allow for the unit to operate 24 hours between adjustments. If the 2 degree adjustment is not enough another adjustment can be made. The maximum highest setting is 40 degrees and the minimum lowest setting is 32 degrees. If the settings need to go above or below this point there may be other contributing factors as to the cause of the temperature variances, please contact the factory at 1-800-621-8560.

Control Settings

Randell Control Settings							Randell / Dixell Settings In Order		
Eliwell Setting in Order By Folder			SSAC-XXSC Open Display Case				XR20CE*		SSAC Open Display
Purchased / Stock Part Number			RF CNT0601 Eliwell		RF CNT0501 Dixell Cross Reference		Purchased part #	RF CNT0501	
Folder	Code		Yes	Code			Replacement part #	RP CNT0601	
	Set	Thermostat set point	34	Set	Set	33			
CP							Modifications (Shown in RED)	Yes	
	DIF	Thermostat Differential (hysteresis)	6	DIF	HY	4	Code Locked	Yes	
	HSE	Upper Set Point	45	HSE	US	45	Set Thermostat set point	33	
	LSE	Lower Set Point	32	LSE	LS	32	HY Thermostat Differential (hysteresis)	4	
	Ont	Compressor ON (probe failure)	8	Ont	COnt	8	LS Lower Set Point	32	
	Oft	Compressor OFF (probe failure)	2	Oft	COF	4	US Upper Set Point	45	
	dOn	Output delay @ Startup (Compr)	0	dOn			Ot Offset Room Temp	7	
	dOF	Anti-Cycle Time (min off after cycle)	1	dOF	AC	1	P2P 2nd Probe Present	Y	
	dbi	Compr Start to Start Delay (min)	4	dbi			OE Evaporator Probe Calibration	0	
	OdO	Output delay @ Startup (All Relays)	0	OdO	OdS	0	OdS Output delay @ Startup	0	
dEF							AC Anti-Cycle Time (min off after cycle)	1	
	dtY	Defrost Type	0	dtY	tdF		COnt Compressor ON time (probe failure)	8	
	dit	Interval between Defrosts	3	dit	ldF	3	COF Compressor OFF (probe failure)	4	
	dCt	Defrost Count (0=CRT, 1=TT, 2=COT)	1	dCt			CF °C /°F	F	
	doh	Start defrost delay	0	doh	dSd		rES Resolution 0.0°C (only °C)	in	
	dEt	(Maximum) length of Defrost	25	dEt	ndF	25	dTE Defrost Termination Temp	43	
	dSt	Defrost Termination Temp	43	dSt	dtE	43	ldF Interval between Defrosts	3	
	dPo	First defrost at startup	Y	dPo	dPo		ndF (Maximum) length of Defrost	25	
Fan							dFd Display during Defrost	it	
	dt	Drip time after defrost end	1	dt	Fdt		dAd Max display delay after defrost	20	
diS							i1P Digital Input Polarity	CL	
	LOC	Locked	y	LOC	Code	Code	did Digital Input Alarm Delay	5	
	PAI	Password	0	PAI			odc Open Door Compressor Status	no	
	ndt	Decimal Point		ndt	rES		rEL Software Info	-	
	CA1	Room Probe Calibrate (Offset Temp)	7	CA1	Ot	7	Ptb Software info	-	
	CA2	Evaporator Probe Calibration	0	CA2	OE	0			
	ddL	Display during Defrost	1	ddL	dFd	it			
	dro	°C /°F	1	dro	CF	F			
CnF									
	H00	Probe Selection PTC / NTC	0	H00	PbC				
	H42	2nd Probe Present	Y	H42	P2P	Y			
	rEL	Software Info	-	rEL	rEL	-			
	tAb	Software info	-	tAb	Ptb	-			
FPr									
	UL	Up Load to Copy Card		UL					
	dL	Down Load to Copy Card		dL					
	Fr	Erase Copy Card		Fr					

Control with "fnc" button = Eliwell Control = RF CNT0601

DIXELL CONTROL SETTING INSTRUCTIONS

HOW TO CHANGE A PARAMETER VALUE

To change the parameter's value operate as follows:

- 1.- Enter the Programming mode by pressing the Set and Down Arrow for 3 seconds (the defrost and water drops symbol will start blinking)
 - 2.- Select the required parameter.
 - 3.- Press the "SET" key to display its value. (Now only the defrost symbol is blinking).
 - 4.- Use up or down arrow to change its value.
 - 5.- Press "SET" to store the new value and move to the following parameter.
- To Exit: Press SET + up arrow or wait 15 seconds without pressing a key.

THE HIDDEN MENU

The hidden menu includes all the parameter of the instrument.

HOW TO ENTER THE HIDDEN MENU

- 1.- Enter the Programming mode by pressing the set + down arrow key for 3 seconds (the defrost and water drops symbol will start blinking)
- 2.- When a parameter is displayed keep pressed the Set + down arrows for more than 7 seconds. The Pr2 label will be displayed immediately followed from the HY parameter. **NOW YOU ARE IN THE HIDDEN MENU.**
- 3.- Select the required parameter.
- 4.- Press the "SET" key to display its value (Now only the defrost symbol LED is blinking).
- 5.- Use up or down arrow to change its value.
- 6.- Press "SET" to store the new value and move to the following parameter.

HOW TO LOCK THE KEYBOARD.

- 1.- Keep pressed for more than 3 seconds the up and down arrow keys.
- 2.- The "POF" message will be displayed and the keyboard will be locked. At this point it will be possible only to see the set point or the **MAX** or **Min** temperature stored.
- 3.- If a key is pressed more than 3 seconds the "POF" message will be displayed.

TO UNLOCK THE KEYBOARD.

- 1.- Keep pressed together for more than 3 seconds the up and down arrow keys till the "POn" message will be displayed.

Preventive Maintenance

Randell strongly suggests a preventive maintenance program which would include the following **Monthly** procedures:

1. Cleaning of all condenser coils. Condenser coils are a critical component in the life of the compressor and must remain clean to assure proper air flow and heat transfer. Failure to maintain this heat transfer will affect unit performance and eventually destroy the compressor. Clean the condenser coils with coil cleaner and/or a vacuum, cleaner and brush.

NOTE: Brush coil in direction of fins, normally vertically as to not damage or restrict air from passing through condenser.

2. Clean fan blade on the condensing unit.
3. Clean and disinfect drains with a solution of warm water and bleach.
4. Clean and disinfect drain lines and evaporator pan with a solution of warm water and bleach.
5. Clean all gaskets on a weekly if not daily basis with a solution of warm water and a mild detergent to extend gasket life.

NOTE: DO NOT USE SHARP UTENSILS.

RECOMMENDED CLEANERS FOR YOUR STAINLESS STEEL INCLUDE THE FOLLOWING:

JOB	CLEANING AGENT	COMMENTS
Routine cleaning	Soap, ammonia, detergent Medallion	Apply with a sponge or cloth
Fingerprints and smears	Arcal 20, Lac-O-Nu, Ecoshine	Provides a barrier film
Stubborn stains and discoloration	Cameo, Talc, Zud, First Impression	Rub in the direction of the polish lines
Greasy and fatty acids, blood, burnt-on foods	Easy-Off, Degrease It, Oven Aid	Excellent removal on all finishes
Grease and Oil	Any good commercial detergent	Apply with a sponge or cloth
Restoration/Preservation	Benefit, Super Sheen	Good idea monthly

Reference: Nickel Development Institute, Diversey Lever, Savin, Ecolab, NAFEM.

NOTE: Do not use steel pads, wire brushes, scrapers, or chloride cleaners to clean your stainless steel. CAUTION: DO NOT USE ABRASIVE CLEANING SOLVENTS, AND NEVER USE HYDROCHLORIC ACID (MURIATIC ACID) ON STAINLESS STEEL.

NOTE: Do not pressure wash equipment as damage to electrical components may result.

Preventive Maintenance (cont.)

Proper maintenance of equipment is the ultimate necessity in preventing costly repairs. By evaluating each unit on a regular schedule, you can often catch and repair minor problems before they completely disable the unit and become burdensome on your entire operation.

For more information on preventive maintenance, consult your local service company or CFESA member. Most repair companies offer this service at very reasonable rates to allow you the time you need to run your business along with the peace of mind that all your equipment will last throughout its expected life. These services often offer guarantees as well as the flexibility in scheduling or maintenance for your convenience.

Randell believes strongly in the products it manufactures and backs those products with one of the best warranties in the industry. We believe with the proper maintenance and use, you will realize a profitable return on your investment and years of satisfied service.

Electrical Diagram

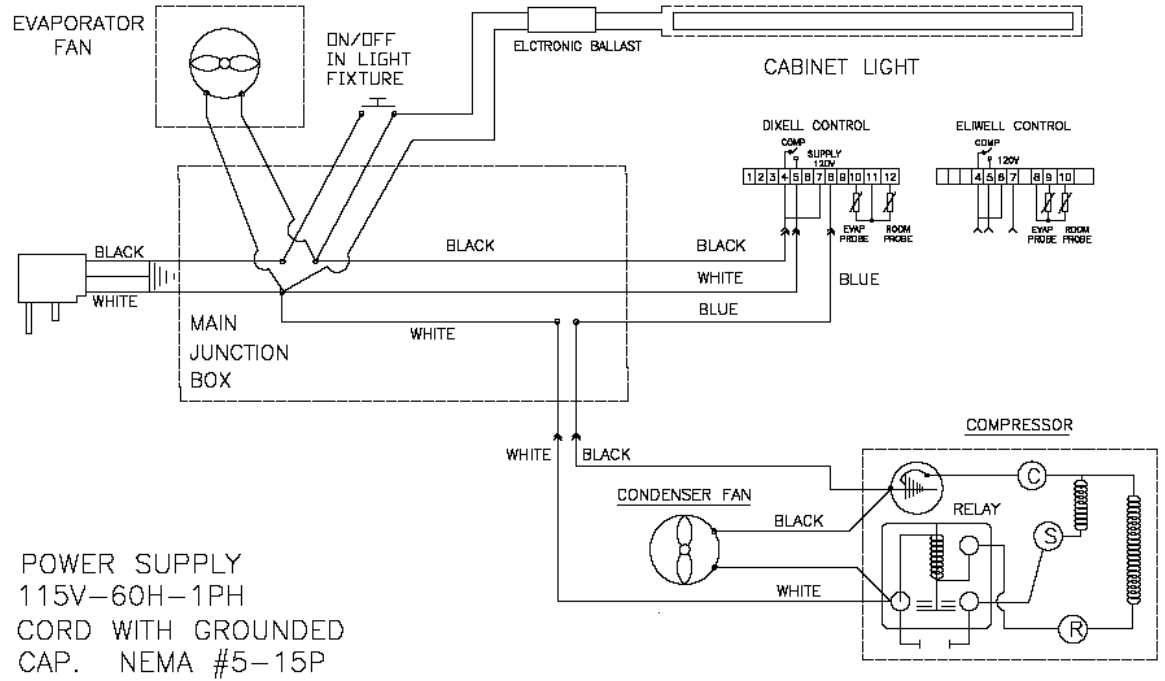

Trouble Shooting Guide

SYMPTOM	POSSIBLE CAUSE	PROCEDURE
Unit doesn't run	<ol style="list-style-type: none"> 1. No power to unit 2. Temperature control turned off 3. Temperature control faulty 4. Compressor overheated 5. Condenser fan faulty 6. Overload protector faulty 7. Compressor relay faulty 8. Compressor faulty 	<ol style="list-style-type: none"> 1. Plug in unit 2. Check temperature control 3. Test temperature control 4. Clean condenser coil 5. Service condenser fan 6. Test overload 7. Test relay 8. Call for service at 800-621-8561
Unit short cycles	<ol style="list-style-type: none"> 1. Condenser coil dirty 2. Condenser fan faulty 3. Compressor faulty 4. Overload repeatedly tripping 	<ol style="list-style-type: none"> 1. Clean coil 2. Service fan and motor. 3. Call for service at 800-621-8561 4. Check outlet voltage
Unit runs constantly	<ol style="list-style-type: none"> 1. Condenser coil dirty 2. Condenser fan faulty 3. Room ambient too high 4. Room humidity too high 	<ol style="list-style-type: none"> 1. Clean coil 2. Service condenser motor 3. Reduce room temp to 75F 4. Set room lower
Unit not cold enough	<ol style="list-style-type: none"> 1. Temp control set too high 2. Temperature control faulty 3. Condenser coil dirty 4. Refrigerant leaking or contaminated 5. Room ambient too high 6. Room humidity too high 7. Display area is over-filled 	<ol style="list-style-type: none"> 1. Adjust control to lower setting 2. Test control 3. Clean coil 4. Call for service at 800-621-8561 5. Reduce room temp to 75F 6. Set room lower 7. Remove items to load level To 2" below sides and front
Unit too cold	<ol style="list-style-type: none"> 1. Temperature control set too low 2. Temperature control faulty 	<ol style="list-style-type: none"> 1. Adjust control to raise setting 2. Test control
Unit noisy	<ol style="list-style-type: none"> 1. Compressor mountings loose or hardened. 2. Condenser fan damaged or hitting fan shroud 	<ol style="list-style-type: none"> 1. Tighten or replace compressor mountings 2. Inspect condenser fan

Replacement Parts List

OPEN DISPLAY CASE SSAC-40BSC

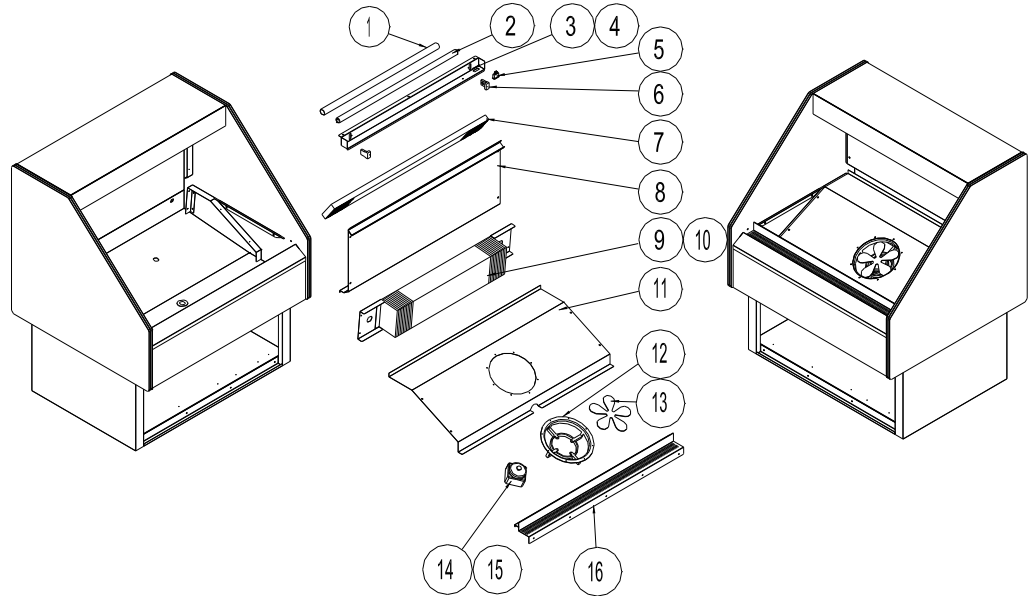

ITEM	DESCRIPTION	PART #
1	36" PLASTIC LIGHT SHEILD	EL SHD018
2	LAMP, FLUORESCENT F30T8CW4 OR F18T8CWK30N	EL TUB018
3	LIGHT MOUNTING BOX	RP CHN0601
4	BALLAST, ELCTRONIC, 120V, T8,	EL BLS0601
5	SWITCH, ROCKR 20A,277V,1HP,125V	EL SWT0502
6	LAMPHOLDER, 660W-600V(13353N) LEVITON 414	EL LGT414
7	PERFORATED AIR BAFFLE	RP BFL0601
8	INTERIOR BACK PANEL	RP PNL0614
9	COIL, 6" X 27" 4 ROW STAGED FIN	RF COI0601
10	TXV R-134 1/2 TON HI TEMP	RF VLV300
11	FAN ASSEMBLY FRONT COVER	RP CVR0601
12	MOUNTING FAN MOTOR RING	RF RNG0201
13	BLADE, 200MMX28 TYPE A PLASTIC	RF BLD0101
14	MOTOR, FAN 6W 115V/60HZ	RF MTR0104
15	WIRE HARNESS, 36" MALE	EL WIR459
16	FRONT AIR RETURN	RP RTN0601

Replacement

Parts List

OPEN DISPLAY CASE SSAC-40BSC

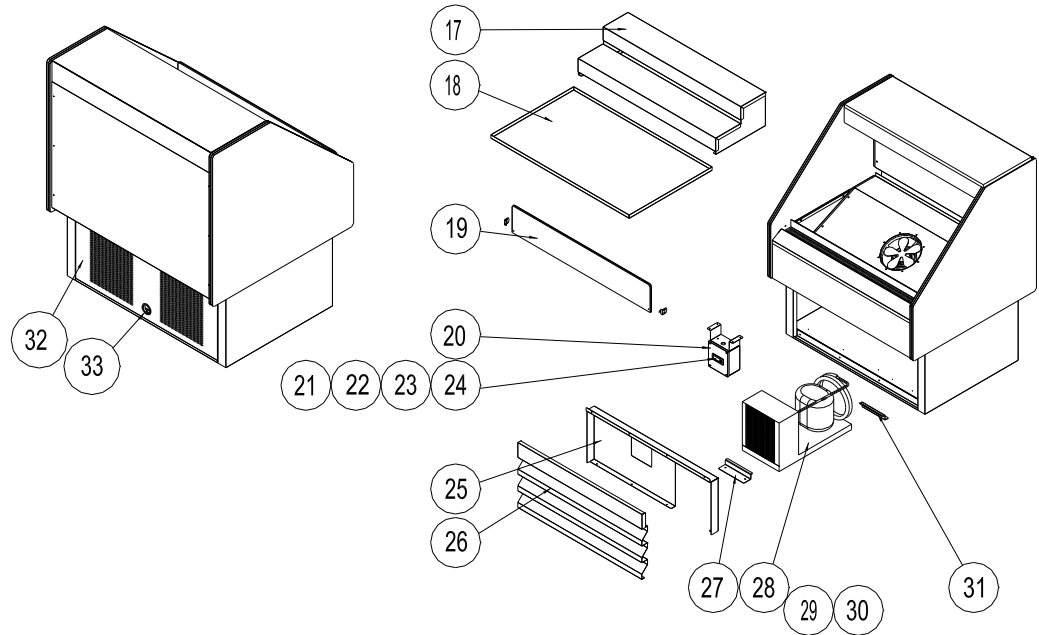

ITEM	DESCRIPTION	PART #
17	REMOVABLE SHELF	RP SHL0603
18	REMOVABLE BOTTOM SHELF	RP SHL0602
19	ACRYLIC SHIELD WITH MOUNTING BRACKETS	RP SHD0602
20	CONTROL JUNCTION BOX	RP BOX0601
21	ELECTRONIC CONTROL	RP CNT0601
22	NTC WATERPROOF PROBES	RF CNT0505
23	WIRE HARNESS, DIXELL XR20CE MALE	EL WIR0501
24	WIRE HARNESS, DIXELL XR20CE FEMALE	EL WIR0502
25	BAFFLE DIVIDER CONDENSING UNIT	RP DIV0603
26	FRONT BASE PANEL	RP PNL0615
27	FRONT COMPRESSOR HOLD DOWN CLIP	RP CLP0604
28	CONDENSING UNIT	RF CON0006
29	FILTER-DRIER	RF FLT251
30	POWER CORD	EL WIR461-90
31	REAR COMPRESSOR HOLD DOWN CLIP	RP CLP0603
32	LOUVERED PANEL	RP LVR0602
33	2" SNAP-IN GROMMET	EL GRM200