

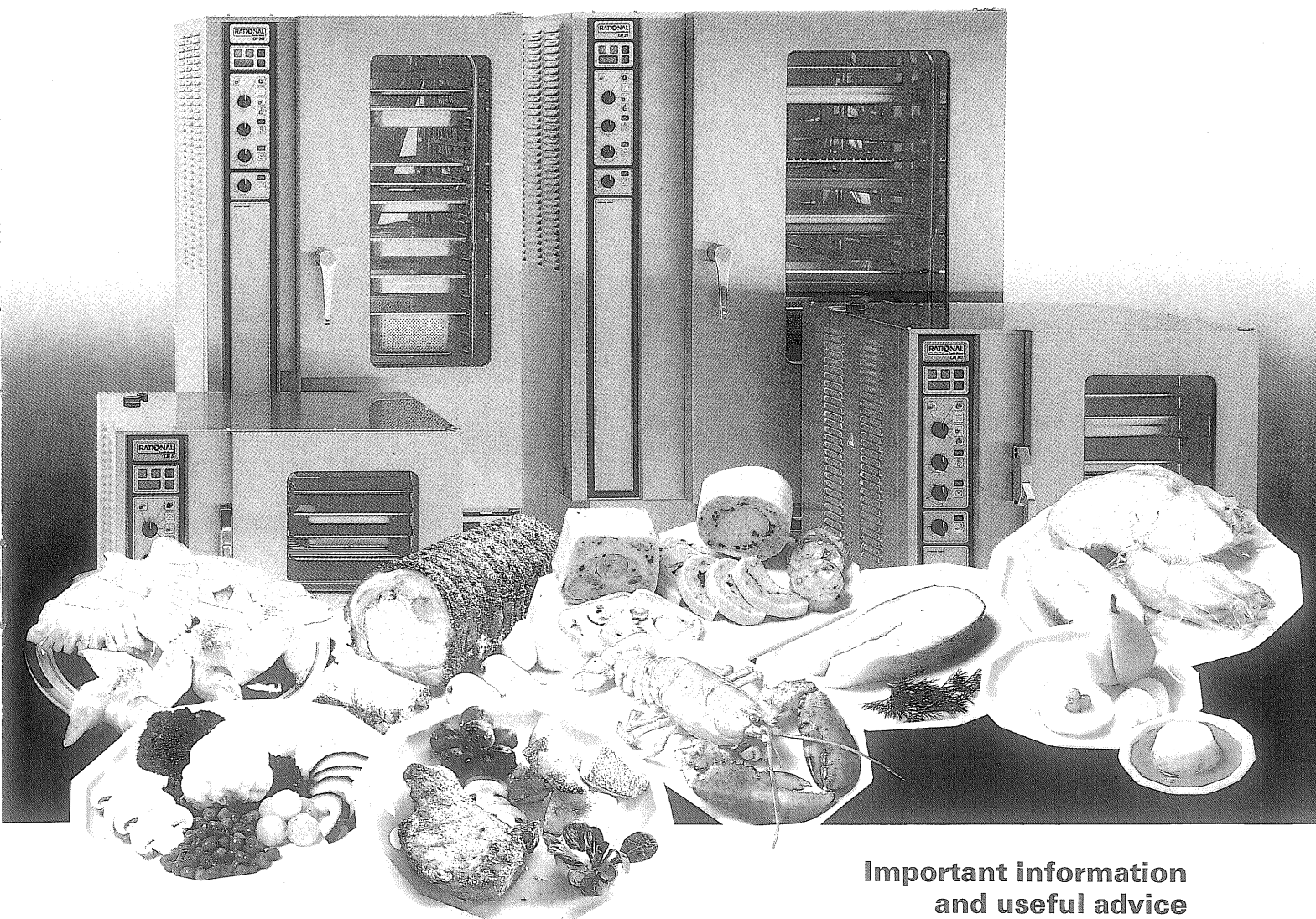

# *Manual* *Combi-Steamer CM*



**Important information  
and useful advice  
for the work with the  
RATIONAL Combi-Steamer CM.**

## Your Customer Service :

---











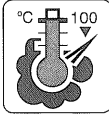

**We grant a 12 month guarantee valid from date of invoice, except damages caused on glass, light bulbs and gaskets.**

	<b>For inquiries please indicate the following dates of your unit :</b>
	<b>RATIONAL Combi-Steamer</b> <b>CM</b> _____
	<b>Unit serial No. :</b> _____
	<b>Your unit was checked by :</b> _____

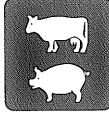
**In case you may need further assistance, do not hesitate to call us:  
Telephone: 05 82/48 03 88**

# Contents

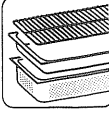
Dear Customer	4
<b>Control Panel of the RATIONAL Combi-Steamer CM</b>	5
<b>Explanation of Controls</b>	6-7

<b>Features of the RATIONAL Combi-Steamer CM</b>			
<b>Loading and Removal</b>		8, 9	
<b>The Cooking Method of the RATIONAL Combi-Steamer CM</b>		10, 11	
<b>Steaming Mode</b>		12, 13, 14, 15	
<b>Hot Air Mode</b>		16, 17	
<b>Combi-Steaming Mode</b>		18, 19, 20	
Variable reheating programs		21	
<b>Forced Steaming</b>			
<b>Vario-Steaming Mode</b>		22, 23	
<b>Operating mode Reheating</b>		24, 25	
<b>Cooking with Core Temperature (Meat Probe)</b>		26, 27	
<b>Examples Beef, Veal, Pork</b>	CM 6, CM 101 CM 201, CM 20	28, 29 30, 31	
<b>Examples Game, Poultry, Pies, Fish, Seafood</b>	CM 6, CM 101 CM 201, CM 20	32, 33 34, 35	
<b>Examples Vegetables, Side Dishes</b>	CM 6, CM 101 CM 201, CM 20	36, 37 38, 39	
<b>Examples Desserts, Pastry</b>	CM 6, CM 101 CM 201, CM 20	40, 41 42, 43	
<b>Working with Original RATIONAL Gastronorm-containers and grids</b>		44, 45	
<b>Accessories</b>		46, 47, 48, 49	
<b>Cleaning Descaling Miscellaneous</b>		50, 51	
<b>Installation and Connection</b>		52, 53	
<b>Check up before starting the unit</b>		54	
<b>Interior Lightning</b>		55	
<b>Connection diagrams</b>		56, 57, 58, 59	

## Dear Customer,

---

we congratulate you on your wise choice to buy a RATIONAL Combi-Steamer CM.

With this RATIONAL Combi-Steamer CM you possess the top unit among the Combi-Steamer's at the market. It is the result of the Original RATIONAL Combi-Steamer's further development based on the close contact with our customers – an innovation for the demanding cook, a unit of almost unlimited possibilities. 5 modes offer you almost all cooking methods of the traditional cooking cuisine in only one unit.

We have directed our special attention to solid workmanship, high functional safety and precise regulation systems and especially to simple, practicable operation.

Still we recommend to study this manual for the RATIONAL Combi-Steamer CM carefully. Only in this way you will really profit from the manifold possibilities and advantages of the RATIONAL Combi-Steamer CM.

Please let us know about your practical experience, your suggestions and ideas to share them with our other customers.

And now enjoy your new RATIONAL Combi-Steamer CM.

**RATIONAL Großküchentechnik GmbH**

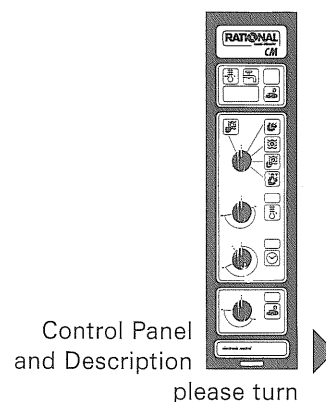

# Control Panel of the RATIONAL Combi-Steamer CM

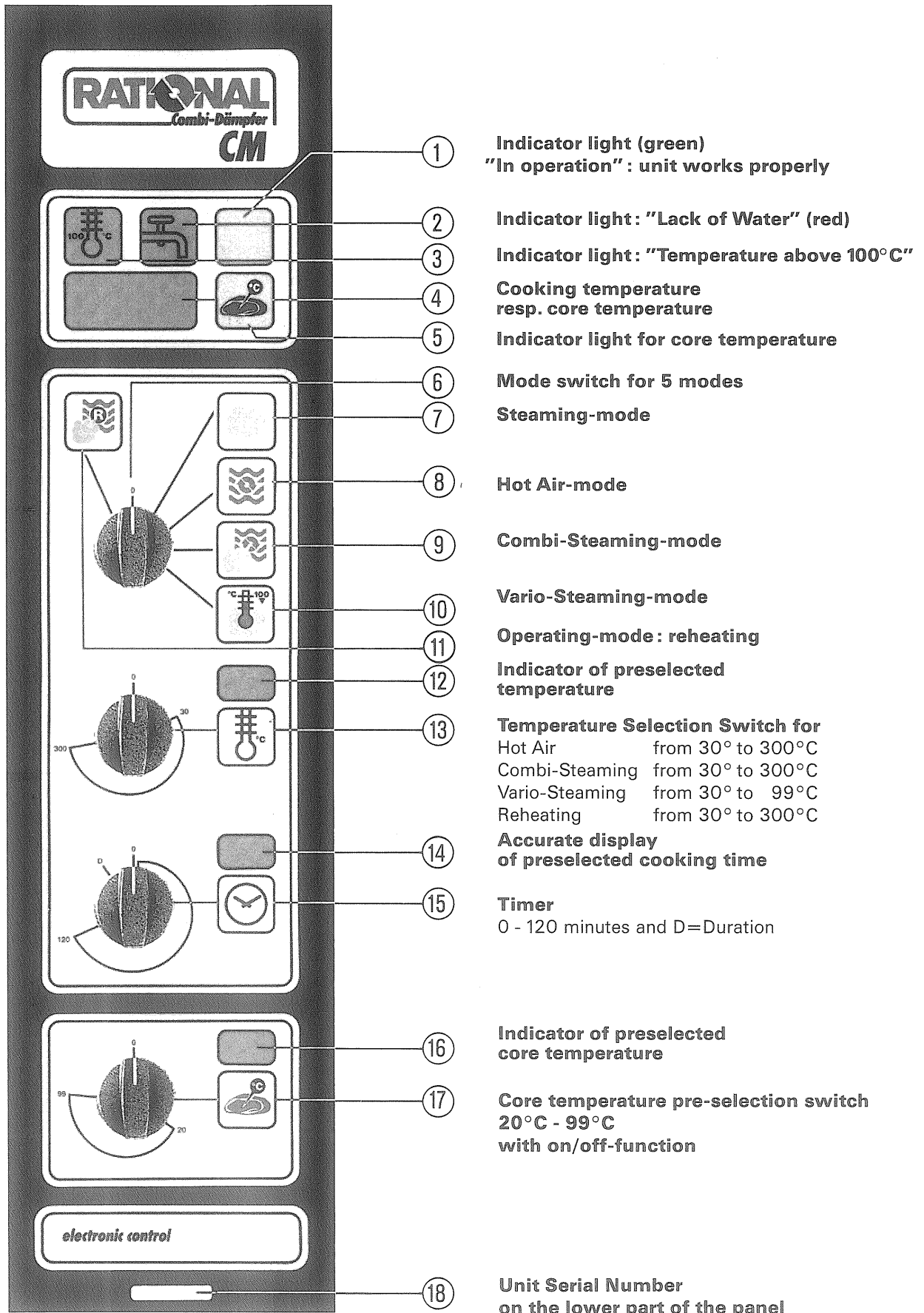

- ① Indicator light (green)  
"In operation": unit works properly
- ② Indicator light: "Lack of Water" (red)
- ③ Indicator light: "Temperature above 100°C"
- ④ Cooking temperature  
resp. core temperature
- ⑤ Indicator light for core temperature
- ⑥ Mode switch for 5 modes
- ⑦ Steaming-mode
- ⑧ Hot Air-mode
- ⑨ Combi-Steaming-mode
- ⑩ Vario-Steaming-mode
- ⑪ Operating-mode: reheating
- ⑫ Indicator of preselected  
temperature
- ⑬ Temperature Selection Switch for  
Hot Air from 30° to 300°C  
Combi-Steaming from 30° to 300°C  
Vario-Steaming from 30° to 99°C  
Reheating from 30° to 300°C
- ⑭ Accurate display  
of preselected cooking time
- ⑮ Timer  
0 - 120 minutes and D=Duration
- ⑯ Indicator of preselected  
core temperature
- ⑰ Core temperature pre-selection switch  
20°C - 99°C  
with on/off-function
- ⑱ Unit Serial Number  
on the lower part of the panel

# Explanation of Controls

---

- ① **Indicator "Unit in Operation"**  
The RATIONAL Combi-Steamer CM has an automatic self-control. The indicator ① constantly lights up green, when the RATIONAL Combi-Steamer CM is in operation and is working properly.
- ② **Indicator: "Lack of water"**  
When water supply is interrupted. This light ② will flash red and the unit will switch itself off when the water faucet connected to the unit has not been opened, for instance. The autocontrol feature of the unit blocks all steaming functions. When the lack of water has been remedied (by opening the faucet or cleaning the filter at the inlet end of the magnetic valve) the unit automatically switches itself on again. The Combi-Steamer CM is ready to operate again, the green "In Operation" indicator light ① comes on. If the warning light ② continues to flash, there may be a malfunction in the SC automatic feature.
- ③ **Warning light: "Temperature higher than 100°C"**  
When changing quickly from the "Hot-air" mode or the "Combi-Steaming" mode to the "Steaming" mode or "Vario-Steaming" mode it can happen that the temperature inside the oven is still higher than 100°C at first. In this case the warning light ③ "Temperature higher than 100°C" lights up red. The unit's operation is not influenced. Once the temperature has reached 100°C, the warning light goes out.  
— Sensitive food such as rice, cauliflower, etc., especially when prepared in small quantities, should not be steamed with a temperature higher than 100°C.
- ④ **Display of cooking temperature resp. core temperature**  
The temperature inside the unit is constantly shown in this display ④.  
Exception:  
In the "Steaming" mode this display does not work, as the cooking temperature in this mode is fixed to 100°C. When working with the meat probe the display ④ will show the core temperature instead of the cooking temperature.
- ⑤ **Indicator for core temperature (meat probe)**  
This indicator ⑤ lights up, when the core temperature function has been switched on with the core temperature selection switch ⑭.
- ⑥ **Mode Switch**  
With this switch ⑥ the mode desired can be selected. During the cooking process the mode can be changed at any time.
- ⑦ **Steaming-Mode**  
Set the mode switch to the "Steaming" mode ⑦. In addition the desired cooking time will be set with the timer ⑮. The display ④ is out of order, as in this mode the RATIONAL Combi-Steamer CM works as pressureless steamer with a fixed temperature of 100°C (see pages 12, 13, 14).
- ⑧ **Hot-Air-Mode**  
Set the mode switch to the "Hot-Air" mode ⑧. In addition the desired cooking temperature is selected with the temperature selection switch ⑬ and the necessary cooking time is set with the timer ⑮. The display ④ will show the actual cooking temperature (see pages 16, 17).
- ⑨ **Combi-Steaming-Mode**  
Set the mode switch to the "Combi-Steaming" mode ⑨. In addition the desired cooking temperature is selected with the temperature selection switch ⑬ and the necessary cooking time is set with the timer ⑮. The display ④ will show the actual cooking temperature (see pages 18, 19, 20).
- ⑩ **Vario-Steaming-Mode**  
Set the mode switch to the "Vario-Steaming" mode ⑩. In addition the desired cooking temperature is selected with the temperature selection switch ⑬ and the necessary cooking time is set with the timer ⑮. The display ④ will show the actual cooking temperature (see pages 22, 23).
- ⑪ **Operating mode: Reheating**  
Set the operating mode selector switch ⑪ to "Reheating". The desired temperature is set with the temperature select switch ⑬ and the cooking time is preset with the timer ⑮. The display panel ④ shows the temperature within the unit (o. f. pages 24, 25).
- ⑫ **Preselected cooking temperature display**  
This display ⑫ shows the preselected cooking temperature for the "Hot Air", "Combi-Steaming", "Vario-Steaming" and "Reheating" modes.
- ⑬ **Temperature selector switch**  
The desired temperature for the "Hot Air", "Combi-Steaming", "Vario-Steaming" and "Reheat" modes is preselected by turning the temperature selector switch ⑬ clockwise.

# Explanation of Controls

---

**⑭ Accurate display of preset cooking time**

By turning the knob of the timer switch, the accurate display shows the desired cooking time. From the moment the timer is preset, it permanently displays the actual cooking time that is still left.

**⑮ Timer**

By turning the knob of the timer ⑮ clockwise, the desired cooking time is set. The preselected cooking time is displayed in the display panel ⑭. When the preset cooking time is over, a buzzer comes on and the unit switches off automatically. By turning the mode selector switch ⑧ back to "0" the unit is switched off completely. If you turn the timer knob ⑮ counterclockwise to position "D" (Duration = Permanently on) the RATIONAL Combi-Steamer CM will work permanently. If you turn the operating mode switch ④ to "0" the unit is switched off. The cooking time can be changed at any time during the cooking process.

**⑯ Display of the preselected core temperature**

This display ⑯ will show the preselected core temperature (20°C-99°C).

**⑰ Core temperature selection switch within on/off-function**

By turning the temperature selection switch ⑰ the desired core temperature is set. The preselected core temperature is shown in the display ⑯. The core temperature indicator ⑥ lights up. The display ④ will show the actual core temperature. When working with the meat probe the cooking time is regulated by the actual core temperature. Therefore the timer ⑮ is out of order.

When the preselected core temperature is reached, the unit buzzes and is switched off automatically. By turning the mode switch ⑥ back to "0", the unit is switched off completely.

**Attention:**

In case a higher core temperature is desired once the preselected one has been reached, the core temperature selection switch ⑰ has to be turned to "0" first, before the core temperature can be changed.

**⑱ Unit serial number**

Under this serial number your unit is registered in our factory. In case of any inquiries, calls on customer services, etc. please indicate this serial number.

## Notes

---

---

---

---

---

---

---

---

---

---

---

---

---

---

---

---

---

---

---

---

---

---

---

---

---

## Features of the RATIONAL Combi-Steamer CM

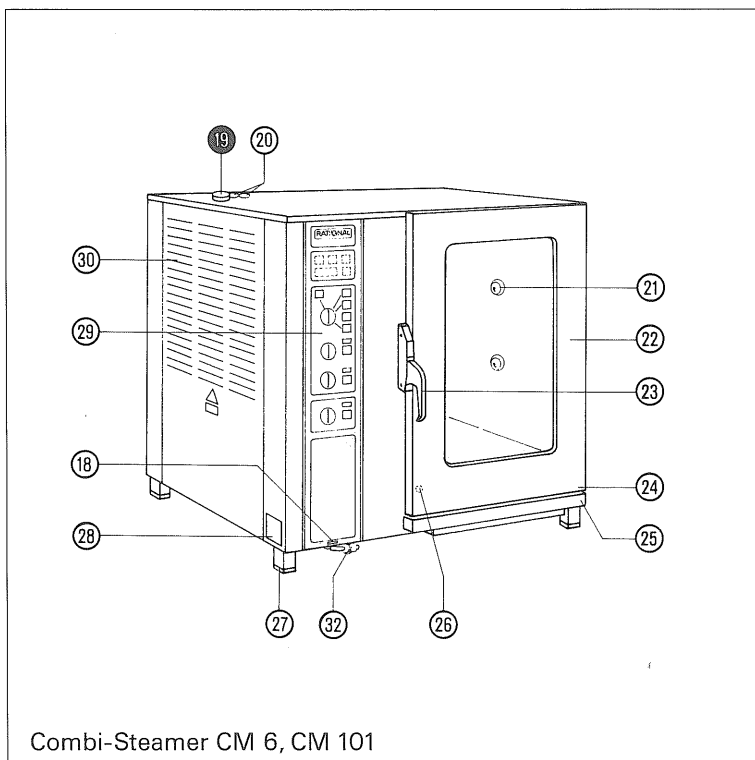

Combi-Steamer CM 6, CM 101

⑱ **Unit serial number**

⑲ **Descaling inlet**  
at the same time safety valve

**Attention:**

**Don't place anything on top of the safety valve and mind not to block it in any way. It is essential that the safety valve can move freely and thus can accomplish its safety function.**

⑳ **Air valves**

㉑ **Interior light**  
(with shock-resistant glasses)

㉒ **Unit's door**

㉓ **Door handle** (one-hand-operation)

㉔ **Integrated door drip collector**

㉕ **Drip collector**  
(remove for cleaning)

㉖ **Door contact switch**

㉗ **Adjustable legs**

㉘ **Unit identification plate**  
with all important data such as power input, voltage, number of phases and frequency as well as unit model and unit serial number.

㉙ **Control panel**  
(see inside page 5)

㉚ **Protection cover of the installation cabinet**  
(with air vents)

㉛ **Rinsing jet nozzle with automatic hose rewind**

㉜ **Easier insert of mobile oven racks**

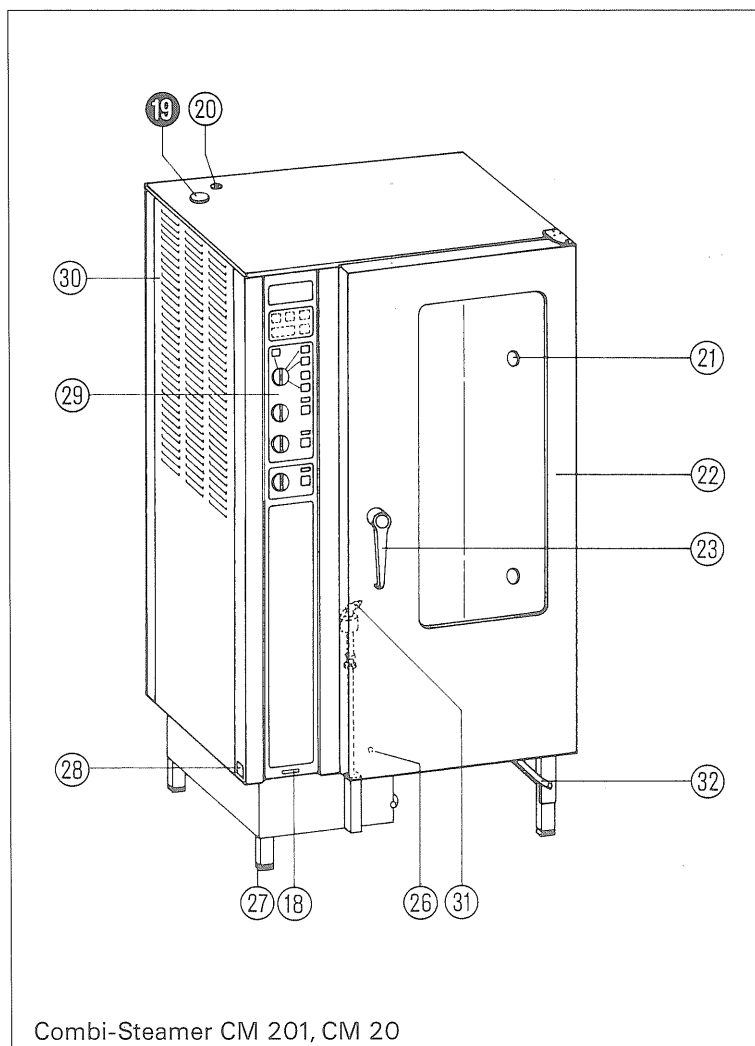

Combi-Steamer CM 201, CM 20





## Loading and Removal

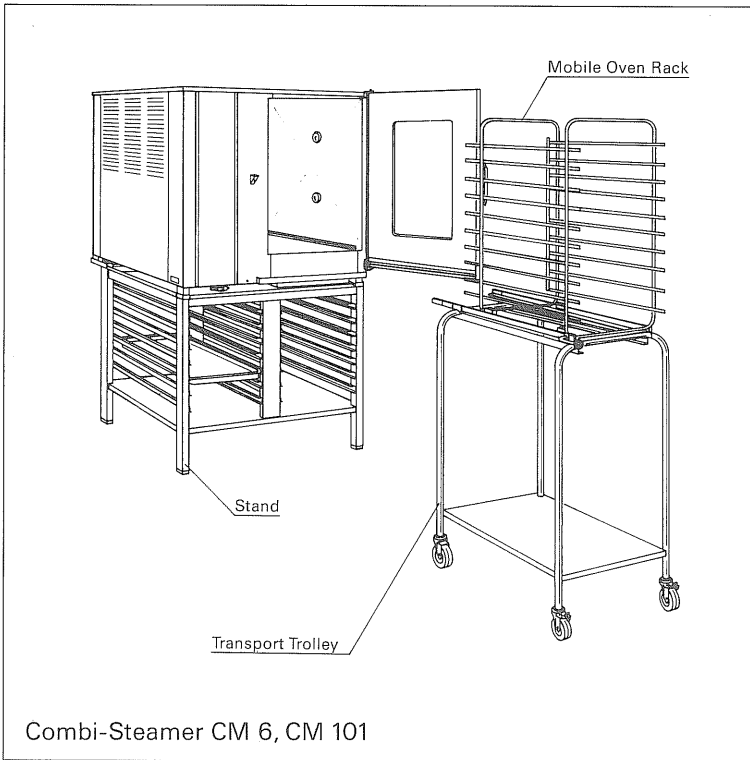

### Loading

Place the food according to the handling instructions onto the Original RATIONAL GN-grids or fill it into containers and slide the mobile oven rack into the unit. Insert the mobile oven rack well until it locks into place. If a large amount of food is to be processed, it is recommended to load the mobile oven rack outside the unit. For this purpose the RATIONAL transport trolley (accessories) is used. High cooking capacity (output) and better working sequence as well as quicker exchange of loads are achieved with the use of additional mobile oven racks and transport trolleys.

### Removal

After steaming open the door slowly.

#### **CAUTION! STEAM!**

When the door is opened, the unit is switched off automatically. The fan rotates till it comes to a stop.

Don't spray water into the hot cooking cabinet.

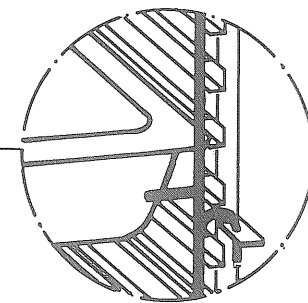
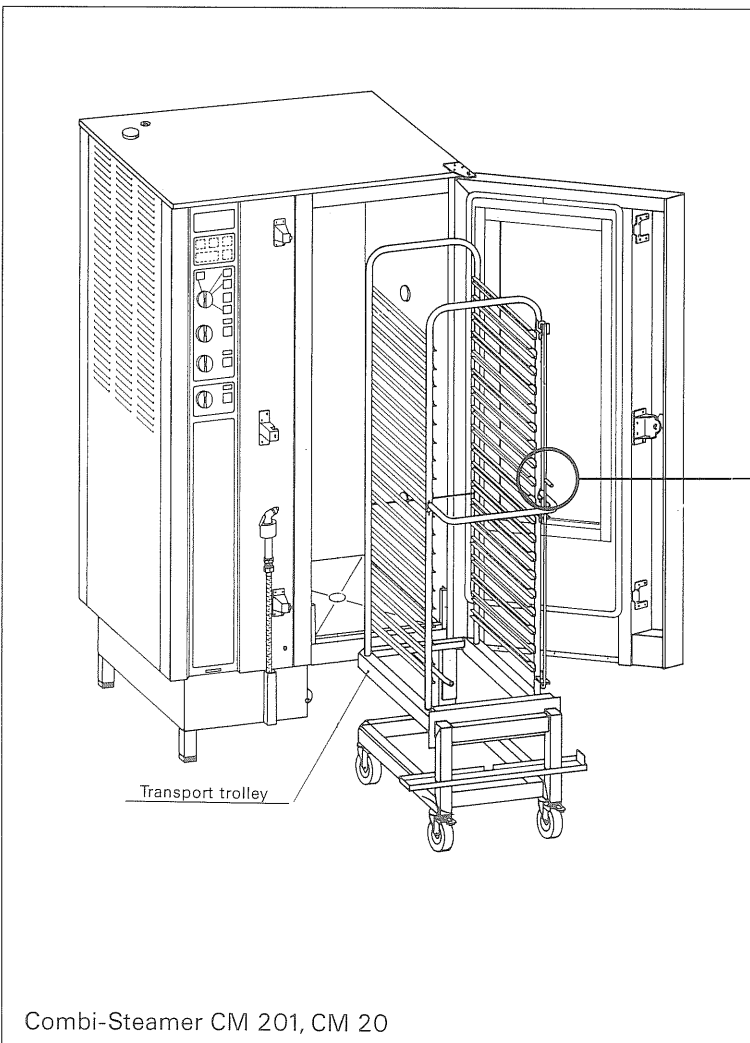

GN container catch for safe loading

All RATIONAL Combi-Steamers CM 20 are equipped with a motor brake. Within 3–4 sec the fan wheels are brought to a standstill.

#### **Attention!**

Upon termination of the cooking process, do not set the mode switch to "0", as otherwise the motor brake will not function.



## The Cooking Method

---

The RATIONAL Combi-Steamer CM is equipped with two cooking energies

# MOIST HEAT + DRY HEAT

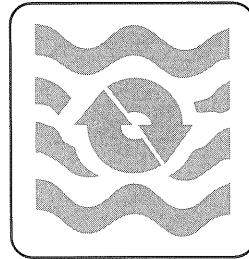
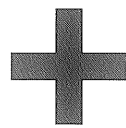
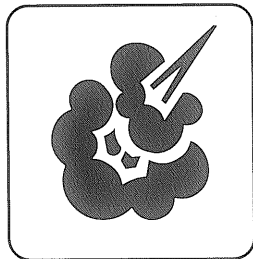

**STEAM + HOT AIR**

These two cooking media can be used either

**singly  
in sequence  
or combined.**

The RATIONAL Combi-Steamer CM offers the possibility to operate almost all cooking methods of the traditional cuisine in only one unit.



## Five Modes are at Your Disposal

---

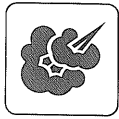

### Steaming mode moist heat

The high capacity steam generator produces hygienic fresh steam. This is let pressureless into the interior cabinet and is circulated at high speed by the fan. The patented regulation system controls the input of steam; only as much steam is let in as the food is able to absorb. The cooking temperature is fixed to 100°C.

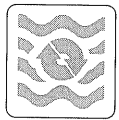

### Hot Air mode dry heat

High capacity heating elements heat the dry air. The fan circulates this hot air equally inside the interior cabinet. The temperature can be selected between 30° to 300°C.



### Combi-Steam mode moist heat + dry heat

The two cooking media Steam (moist heat) and Hot Air (dry heat) can be combined by a regulation system. This combination creates a hot-humid climate for a specially intensive cooking. The temperature can be selected between 30° to 300°C. The interior cabinet continuously contains the optimal humidity, which will prevent the drying out of the food.

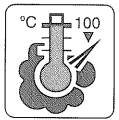

### Vario-Steam mode moist heat in the low temperature area of 30° to 99°C.

The electronic regulation system with the temperature sensor at one degree precise keeps the preselected cooking temperature within the interior cabinet at a constant level. The sensitive control and regulation technology guarantees an optimal cooking climate, which meets the requirements of the processed food. The temperature can be selected freely between 30°C to 99°C. Temperature allowance is +/- 2°C.



### Operating mode Reheating moist heat + dry heat

Both cooking methods steam (moist heat) and hot air (dry air) are specially combined in a control system tailored to the special needs of reheating. Both modes create a perfect environment in the oven that not only prevents food from drying out but also prevents the formation of water puddles and rims. The temperature can be selected from 30° to 300°C.

**According to the preparation desired  
you can choose or combine the equivalent modes –  
singly, in sequence or combined.**

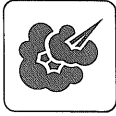

# Steaming Mode = Moist Heat

## instead of cooking with water in pots and kettles

Steaming means to gently cook food by using steam. The RATIONAL Combi-Steamer CM operates this cooking method pressureless with an optimal constant steaming temperature of 100°C. The intensive saturated fresh steam guarantees an equal cooking within the entire interior cabinet. The food is processed without additional water (exception rice).

### Operation :

Set the mode switch ⑦ to the "Steaming" mode. In addition you have to set the timer ⑮ to the desired cooking time. The display ④ is out of order, as in this mode the RATIONAL Combi-Steamer CM works as a pressureless steamer with a steaming temperature of 100°C (see page 5, 6, 7).



### Preheating :

Before loading and after more than three hours "Non-use", the RATIONAL Combi-Steamer CM is to be preheated in the "Steaming" mode until the window is misted over.

### Cooking methods :

Steaming, stewing, blanching, poaching, simmering, soaking, cooking in vacuum.

### Additional possibilities :

Thawing, reconstituting (reheating), preserving, sterilizing.

### Examples of cooking items :

Eggs, hors d'oeuvres, vegetable (frozen or fresh), side dishes (frozen or fresh), fish (frozen or fresh), meat (veal – beef – pork – lamb – game), convenience-products, fruit, various desserts, ... Preserves in jars.

### Advantages :

The technical equipment of the RATIONAL Combi-Steamer CM results in extremely short preheating periods. No more time consuming water reheating. Even when the unit is fully loaded, only a relatively short cooking time is necessary for various food items. As the long preheating periods (e.g. in kettles, pots etc.) no longer exist, a constant production of bigger amounts (broccoli, cauliflower, Brussels sprouts etc.) is guaranteed.

### High food quality

By the processing with steam the valuable taste and flavour elements as well as the food structure are preserved. Steamed food retains its own distinct, typical taste.

Contrary to boiling in water, the food keeps its nutrients and minerals when processed in the "Steaming" mode. If you compare boiled and

steamed vegetable, you will find that steamed food impresses by its appetizing fresh colour. By using relatively shallow containers, the food items are only piled in few layers; bruising is avoided.

### Conservation of vitamins

The RATIONAL Combi-Steamer CM enables a specially gentle, vitamine conserving cooking process, as the usually long preheating periods do no longer exist, only few liquid is used or none at all and the cooking temperature remains slightly below 100°C.

### Firmness of food items

Overcooking is no longer possible (contrary to boiling in pots, kettles or pressure cookers). The grade of firmness resp. softness can be regulated individually.

### Simultaneous steaming of different products

In the RATIONAL Combi-Steamer CM no taste transfer takes place in the "Steaming" mode. This means, that all food can be steamed at the same time, even if they have different constitution and need different cooking times. Loading or unloading of partial amounts are possible at any time.

## Application instructions and advices

### Use of containers

All sorts of vegetables are steamed in perforated or unperforated Original RATIONAL containers.

### Cooking times

Cooking times of vegetable depend on the individual quality. Especially when steaming fresh vegetable it is recommended to check its state after 3/4 of the initial cooking time.

Steamed vegetable tends to soften afterwards. As practise shows, that there is a certain time difference between cooking and serving, it is best not to cook vegetable too soft. This is especially important for carry-out services.

Perforated containers shorten the cooking times. The approximate cooking times also vary depending on the different consumers (restaurants, old peoples homes) and traditional eating habits.

### Blanching

Large amounts can be blanched in a short time. Please observe that the containers are not filled higher than 6 to 8 cm.

### Seasoning

Spices can be added either to the raw or frozen products.



# Steaming Mode = Moist Heat

---

## **Dry seasoning before steaming:**

Prepare a mixture of dry spices and sprinkle it evenly on to the vegetable. Add butter, beurre maitre d'hotel etc. only just before service.

## **Thawing and steaming at the same time**

Thawing means the defrosting of raw frozen food. The food is processed at the same time. The traditional thawing periods are shortened substantially and the quality of the thawed food is improved.

## **Reheating**

Reheating means the warming up of precooked food, which was stored either in frigerators or deepfreezers.

You can reheat: potatoes, noodles, rice, dumplings, fruit, fruit preserves, vegetable, cooked meat, portioned roasts. The use of steam causes an even heat distribution. This results in better appearance, taste and the conserving of nutrients.

Reheating periods depend on the size and the content of the containers. Food is reheated in the same unperforated containers, in which they were already precooked (smaller containers, never place GN-containers on to grids). The reheated food can be given to service immediately in one single operation. This means an enormous saving of time and at the same time improves creativity of food preparation.

Even vegetable such as broccoli, Brussels Sprouts and cauliflower can be served in large amounts (banquets).

## **Tips:**

### **Oil seasoning after cooking:**

Mix oil with dry spices and add it to the vegetable. This seasoned oil spreads evenly and gives the dishes an appetizing, aromatic taste. If necessary steam again for another two minutes.

### **Stocks for sauces (vegetable)**

When unperforated containers are used for cooking, usually there is enough stock for the preparation of sauces.

When you prefer to use perforated containers, insert a container in the bottom rail of the mobile oven rack to collect the stock.

### **Frozen Vegetable**

Do not process frozen vegetable in blocks, but take care to scatter them into the containers. Frozen as well as fresh vegetable can be processed in one operation. Frozen vegetable should not be thawed.

### **Tomates Concasses:**

(skined tomatoes)

Remove stalk – place tomatoes in perforated or

shallow unperforated containers – steam the tomatoes for approx. 30 to 60 sec. according to their ripeness – chill the tomatoes with cold water and skin them.

## **Side Dishes:**

### **Potatoes**

Always cook potatoes in perforated containers. Salt and mix them thoroughly just before steaming. Quarter the potatoes through the width and not through the length (improved steam penetration).

### **Rice**

Add water according to the type of rice. In the RATIONAL Combi-Steamer CM all types of rice preparation turn out excellently and within short time. Please remember that rice continues to swell after cooking. Let the rice soak before steaming, this will shorten the cooking time.

### **Potatoe Dumplings**

Prepare dough as usual, place the dumplings in shallow containers (not too close to each other) and steam them. In case of a longer preparation period cover the dumplings with a damp cloth to avoid that their surface begins to dry. When using convenience-products, the manufacturer's instructions regarding soaking time and adding of water are to be observed.

## **Preparation of Fish**

### **Containers**

Fish can be steamed gently in containers without extra stock etc. For fresh fish (fillets) use 20 mm containers. For bigger pieces or frozen fish use 40 mm containers.

### **Trout "au bleu"**

Salt the inside of the fish slightly, if wanted use "bouquet garni". Place the fish (with the grills and belly flattened out) in a shallow container. Steam without stock. Prepare entire crustaceans (e.g. lobster) as show-pieces. The gentle steaming prevents the loss of valuable protein.

### **A la Carte Preparation**

In the RATIONAL Combi-Steamer CM you can use 1/1, 1/2, 1/3, 2/3 and 2/8 GN-containers, so even small amounts can be cooked and prepared. This guarantees a more rational and flexible a la carte preparation.

The kitchen ranges are no longer blocked. Less pots and pans mean less washing-up.







## Hot Air Mode = Dry Heat

**instead of roasting in convection ovens, in pots and pans, baking in ovens.**

In this mode the food items are cooked with permanent hot air circulation. The hot air is circulated at high speed, surrounds the food items from all sides, closes the pores immediately and the meat remains juicy. The temperature reaches from 30 to 300°C and can be regulated variably.

### Operation :

Set the mode switch ⑥ to the "Hot air" mode ⑧. In addition the desired cooking temperature is selected with the temperature selection switch ⑬ and is shown in the display ⑫. Set the timer ⑬ to the desired cooking time. The display ④ shows the actual cooking temperature inside the interior cabinet (see pages 5, 6, 7),



### Preheating

When the unit is fully loaded or when preparing grilled meat, always preheat the unit at 300°C – not for baking. Load the unit quickly, then select the desired cooking temperature.

### Attention

Before opening the unit's door wait until the fan stops rotating (heat loss).

### Cooking methods :

Toasting, grilling, baking, gratinating ...

### Examples of food items :

Grilled meat, hamburges, steaks, cutlets, medallions, scallops, chicken legs.

Poultry, lamb, hare, saddle of venison, fish frozen or fresh, stuffed vegetable, different sorts of doughs and batters.

## Application instructions and advices

### Loading capacity

The performances stated in the charts are calculated for maximum capacity.

### Oiling

The quality of some dishes can be improved by oiling the surface with either oil or a paprika-oil-mixture (e.g. steaks and poultry). Depending on the amounts this will be done with a brush, spray pistol or by dipping in oil.

### Containers or grids

This is a question of your individual decision. Grids have the advantage, that the top and the bottom sides of roasts etc. will show an even browning. In containers the bottom side of roasts may turn out paler than the top side, when the unit is fully loaded.

Take care that fillet steaks, sirloin steaks, medallions and tenderloins have the same thickness and the cuts of similar sizes are placed on the same grid.

Do not overload grids or containers in order to ensure an even air circulation.

### Cooking times

Cooking times depend on quality, weight and size of the product. The flatter the piece, the shorter its cooking time.

Rule of thumb: every 1 cm meat cut needs approx. 8 to 10 minutes cooking time. Meat cuts of 1,5 to 2 cm thickness show excellent results. Do not beat or flatten the meat.

### Meat covered in bread crumbs

Generally every conventional type of bread crumbs can be used. It is obvious that the grade of browning is also influenced by the ingredients of the breading. To intensify the browning you may use special browning aids.

Press breading firmly to the meat, cover with oil and do not overload the unit. For some dishes it is preferable to use eggs and bread crumbs only. The flouring of grilled meat is disadvantageous.

### Preparation of fish

The flouring of fish fillets is not recommended. For the preparation of fried fish, the granite enamelled containers should be preheated as well.

When preparing large entire fish (pike, perch-pike), wrap the tail in aluminium foil and support it from underneath with raw potatoes.

### Gratinating

Gratinating is done at high temperature.

### Which dishes will be gratinated ?

Some examples of many possibilities:

Soups, white and dark meat, fish and mussels, asparagus, chicory, broccoli, fennel, tomatoes, toasts.

### How to gratinate ?

Always preheat the RATIONAL Combi-Steamer CM at 300°C for gratinating. Load the unit quickly, then select the desired cooking temperature. Use grids and containers (20 mm 1/1 GN) to gratinate toasts, steaks and soups.





## Hot Air Mode = Dry Heat

### Baking

#### What can be baked ?

In the RATIONAL Combi-Steamer CM all types of pastry including biscuits succeed perfectly and show excellent results in quality, appearance and consistency.

#### How to bake ?

According to need and type of food the mode switch is set to the "Hot Air" or the "Combi-Steamer" mode. If necessary, you can switch from one mode to the other. The possibility to add steam during the baking process opens further ranges of application. This is specially important for leavened doughs, french pastry and different bread doughs.

#### What else is important when baking ?

First preheat the unit to the baking temperature.

Always select the baking temperature 20 to 25°C (70 to 80°F) lower than for traditional ovens.

When baking bread or rolls only use every second rail. In case of doubt always select a lower baking temperature. For light mixtures use deep containers to ensure an even baking process.

Baking tins should not be higher than 70 mm.

Baking times may be shorter than with conventional baking methods. When the unit is not fully loaded, take care that the food is evenly distributed in the unit. Use grids for baking rings, tins etc. Mixtures with a high degree of moisture should be reduced slightly in amount.

When the unit is fully loaded, open its door shortly to let the moisture escape (if necessary).

For heavy mixtures (batters, short paste) and well filled tins use granite enamelled containers and insert them every second rail only.

### Notes

---

---

---

---

---

---

---

---

---

---

---

---

---

---

---

---

---

---

---

---

---

---

---

---

---

---

---

---

---

---



# Combi-steaming mode

= Moist Heat  
and Dry Heat

instead of  
roasting in the oven with basting,  
baking in the oven with damping

The "Combi-Steaming" mode combines all advantages of hot steam (short cooking time, low weight loss) and hot air (intensive aroma, appetizing colour). The two cooking media steam and hot air are circulated at high speed, surround the cooking item from all sides; in this way an intensified cooking process is achieved.

The "Combi-Steaming" mode can be used (like the "Vario-Steaming", the "Steaming" and the "Hot

Air" mode) for one complete cooking process from the beginning to the end. It is also possible to use the "Combi-Steaming" mode only for a part of the total cooking process.

For individual preparations the modes can be changed at any time during the cooking process.

The temperature reaches from 30° to 300° C and can be regulated variably.

## This means in practise:

the two cooking media



**Steam (moist heat)** and



**Hot Air (dry heat)**

can be used

**either singly, in sequence or combined.**

You as the expert will know immediately when and for how long you will use the different modes.

It will be easy for you to transfer the conventional cooking methods to the modern

RATIONAL Combi-Steamer-techniques.

Some examples of the manifold application possibilities:



**Steaming +**



**Hot Air**

First cook with steam, then with the hot air mode you can gratinate, brown resp. roast, e.g. gratinated vegetable, cauliflower, fish, roasts for buffet, casseroles etc.

Advantage: Less work, quicker service. This applies for all sorts of vegetable preparation. Also fresh or frozen fish can be prepared variably.

Menu example: garnish steamed fillet of turkey with pineapple and cheese - gratinate with hot air.



**Hot Air +**



**Combi-Steaming**

Start with the hot air mode to dry the surface of the cooking item or to close the pores, then change to the steaming mode, e.g. heavy poultry, shoulder of lamb, french pastry etc.



**Combi-Steaming +**



**Hot Air**

Start with the Combi-Steaming mode, then switch to the hot air mode for final intensive browning (crunchy crust), e.g. stuffed peppers, stuffed turnips, Fillet Wellington, roastbeef, leavened doughs.



**Steaming +**



**Hot Air +**



**Combi-Steaming**

Meat:

First close the pores with steam, then cook by changing from hot air to combi-steaming, e.g. pork roasts with crackling, beef rolls, minced meat etc.

Stuffed vegetable:

First steam shortly, then cook by changing from hot air to combi-steaming, e.g. cabbage rolls, cucumbers, zucchini etc.

This combined cooking process is also used for every type of pastry, which need damp and dry heat during the baking process.



**Vario-Steaming +**



**Hot Air +**



**Combi-Steaming**

First gently steam the cooking item, then change from the hot air mode to the combi-steaming mode to intensify the aroma and the crust, e.g. truffled forcemeat, different sorts of pies and patés, stuffed chicken breasts etc.



# Combi-steaming mode

= Moist Heat  
and Dry Heat

## Operation:

Set the mode switch ⑥ to the "Combi-Steaming" mode ⑨. In addition the desired cooking temperature is selected with the temperature selection switch ⑩ and shown on the display ⑫. Select the desired cooking time with the timer ⑬. The display ④ shows the actual cooking temperature (see pages 5, 6, 7).

## Preheating:

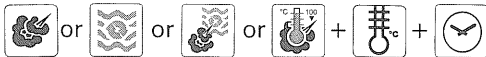

The preheating depends on the first selected mode. See preheating for the "Steaming" mode (page 12) and the "Hot Air" mode (page 16).

## Cooking methods:

"Combi-Steaming", "Combi-Roasting", "Combi-Baking", glazing, gratinating.

## Examples of cooking items:

All big roasts (veal, beef, pork, lamb, game), poultry, chicken, pork legs, beef rolls, meat loafs, minced meat, pies, stuffings, casseroles, roastbeef, Fillet Wellington, vegetable preparations, french pastry, different types of doughs and batters.

## Advantages of the "Combi-Steaming" mode

### Rationalization

For quite a number of food preparation methods it is absolutely necessary to cook with high temperatures as well as with steam. This way the cooking items will keep their typical own taste. Previously two or three different units in several working sequences were needed for this kind of preparation.

Now all these cooking methods can be combined without time wasting interruptions in only one unit, the RATIONAL Combi-Steamer CM.

### Less weight loss

The usual weight loss when roasting in conventional ovens can be reduced by half (on an average).

When cooking a 100 kg roast, this means an additional profit of 80 to 100 meat portions! From the budget point of view this is a convincing argument for this mode.

## Juiciness and individual crusts

By steaming the cooking item, the pores on the surface are closed immediately, due to the quickly congealed protein. This keeps nutrients and juices inside the roasts. The combination of hot air and steam enables an intensive cooking process. Even for big roasts (e.g. entire pork legs) an intensive cooking to the bone is guaranteed. By steaming the meat shortly at the beginning, it will be penetrated by steam and achieves a bigger size. Through the constant exchange between "Hot Air" and the "Combi-Steaming" mode, the roasts will develop a pleasing brown colour as well as an appetizing brown crust.

The meat will have a pronounced roasted taste. An encrusting (burning) of the surface is excluded. Especially pork legs and pork roasts show that the cracklings have an excellent elasticity and juiciness.

When preparing roast beef, the moisture during the Combi-Steaming mode prevents the drying out of the meat.

Generally big roasts stand for their special juiciness and consistency.

The excellent consistency of roasts guarantees optimal portioning.

## Dietary preparation

The preparation of roasts for the dietary kitchen always required a great deal of effort and special care. The RATIONAL Combi-Steamer CM solves this problem in no time. All preparations for the different types of diets can be realised.

## Application instructions and advice

### Loading

Use grids for the loading with big roasts. The grids enable an even cooking of the roasts from all sides. A turning of the cooking item is no longer necessary.

### Temperatures

Rule of thumb: The longer the cooking time, the lower the cooking temperature. This results in less weight loss. The core temperature of cooking items should be observed during preparation.

### Cooking times

The cooking times depend on the quality, the weight and the height of the roasts. The flatter the roasts, the shorter the cooking time. Therefore the values indicated in the charts can vary in practise.



# Combi-steaming mode = Moist Heat and Dry Heat

## Preparation

Do not place the roasts too close to each other in order to ensure an even cooking from all sides. Place cuts of similar size on to the same grids resp. containers. If the meat fibres are parallel to the air circulation, this will enable a better heat absorption and shorten the cooking time by approx. 30 %.

## Glazing

You can glaze your cooking item during the cooking process with the stock collected in the unperforated container.

## Preparation of sauces

Insert an unperforated GN-container in the bottom rail of the mobile oven rack during the "Steaming" mode (the meat is placed on the grids). Condensation is collected in this container and can be used later with the roasted bones to prepare the sauce.

After switching to the "Hot Air" mode, add chopped bones, vegetables and spices etc., let them roast, add the collected stock and leave it during the rest of the cooking process underneath the roast. When the cooking process is finished, season the stock, lengthen or bind the sauce (concentrated sauce) if necessary.

## Reheating of sealed, precooked deep-frozen products in aluminium containers (convenience-products fast-food)

The reheating process is done in the "Combi-Steaming" mode at the temperature of 130° C (265°F).

The period between deep-freeze temperature and eating temperature is considerably reduced by the use of steam, compared with the usual hot air method.

Crusting on the container rims resp. on the product's surface is avoided due to the steam.

Product	weight per container	time in min.	container 1/1 GN
Aluminium containers multiple portions 320/250/45			
Mashed potatoes	2000 g	45	2
Pork roast	2000 g	55	2
Green beans hot-pot	2000 g	45	2
Rice	1500 g	45	2
Aluminium containers single portions 150/110/40			
Mashed potatoes	225 g	20	8
Pork roast	200 g	20	8
Rice	175 g	20	8
Cabbage rolls	275 g	25	8
Stuffed peppers	300 g	25	8

## Notes

---

---

---

---

---

---

---

---

---

---

---

---

---

---

---

---

---

---

---

---

---

---

---

---



# Combi-steaming mode = Moist Heat and Dry Heat

## Variable Reheating in any operating mode

In any of the 5 operating modes of the RATIONAL Combi-Steamer CM

Steaming mode	100° C
Hot air mode	30° - 300° C
Combi-Steaming mode	30° - 300° C
Vario-Steaming mode	30° - 99° C
Reheating mode	30° - 300° C

You can choose your individual reheating program most suited for the product being processed. In addition, by using the core temperature probe, you have the opportunity of setting the exact temperature for serving, down to one degree C. The uses range from reheating meals on plates down to reheating in all of the different GN containers. The selection of the reheating temperature and operating mode depends on the desired product and results. Whether you want to prepare vegetables, garnishings, fruits or crisp, brown pork belly, all with your personal touch, it's no problem for you: with the RATIONAL Combi-Steamer CM you have all the modes and possibilities for temperature selection at your fingertips.

**Use the fifth mode "reheating" for your special requirements, like reheating on plates, platters, banquets, a la carte, etc.** (c. f. page 24).

## Forced steaming

**Use this possibility when things have to be done faster.**

With the RATIONAL Combi-Steamer CM you can not only steam, but also operate **forced steaming**:

that means, pressureless steaming in the combi-steaming mode at a temperature of 110° - 125° C (230° - 260° F).

Practical experience confirms, that this cooking process is specially suitable for products with firm consistency. An intensified cooking and shorter cooking times are achieved.

Examples :

fresh celery	110° C (230° F)
frozen kohlrabi	120° C (250° F)
fresh carottes	115° C (240° F)
potatoes	125° C (260° F)

**Quality knows no compromise.  
Creativity has no limits!**

## Notes

---



---



---



---



---



---



---



---



---



---



---



---



---



---



---



---



---



---



---



---



---

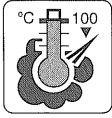

# Vario-steaming mode

= Moist Heat in the low temperature range between 30°–99° C

## instead of cooking in pots, casseroles, kettles and bain maries

The free temperature selection enables to cook with variable cooking temperatures from 30° C to 99° C. The temperature tolerance is +/- 2° C. The sensible control and regulation technology provides a cooking climate that meets the needs of the processed food. The electronic regulation system with the temperature sensor at 1° C precise guarantees, that the preselected cooking temperature is kept constant in the entire cooking cabinet.

## Operation

Set the mode switch ⑥ to the "Vario-Steaming" mode ⑩. In addition the desired cooking temperature is selected with the temperature selection switch ⑬ and is shown in the display ⑫. Set the timer ⑭ to the desired cooking time. The display ④ shows the actual cooking temperature inside the unit (see pages 5, 6, 7).

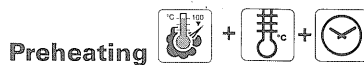

## Preheating

Before loading and after more than three hours non-use, the RATIONAL Combi-Steamer CM is to be preheated in the "Vario-Steaming" mode until the window is misted over.

## Cooking methods:

Scalding, simmering, soaking, poaching, blanching, cooking in vacuum, thawing, reconstituting (reheating), preserving, sterilizing.

## Examples of cooking items:

Egg royale, fillet of salmon-trout, turbot, crustaceans, pies, galantines, patés, fricassée of veal, brisket of beef, poultry, pork, game, lamb, ham, crème caramel, different fruits, preserves in jars (vegetable, meat, fruit).

## The gentle cooking

The gentle cooking in the "Vario-Steaming" mode results in excellent consistency and elasticity for the different sorts of meat and fish preparations. This guarantees a better handling during service. Even delicate preparations such as half a salmon, which tends to dry when prepared the conventional way, can be "vario-steamed" without problem. When "vario-steamed", the preparations of forcemeat, patés, galantines etc. show an enormously improved quality. The constant coagulation at a precisely controlled

## Cooking times in the "Vario-Steaming" mode:

During the traditional preparation (bain marie/ casseroles) the cook paid more attention to the cooking temperature than to the actual cooking time. The same principle applies for the "Vario-Steaming" mode. As recommendations of approximate cooking times you can use the chart of the "Steaming" mode (see pages 28–43).

Generally for the "Vario-Steaming" mode you have to observe:

The lower the cooking temperature, the longer the cooking time.

## Practical findings:

Simply by changing the cooking temperature, completely new tastes can be achieved, such as poaching of salmon trout fillets at 75° or 80° C. Just try yourself! Also in the dietary food preparation you can offer new taste experiences.

## The advantages of the "Vario-Steaming" mode

Until now in the traditional kitchen it was quite a difficult task, if not impossible to cook gently sensitive food in quality and quantity.

The "Vario-Steaming" mode offers for the first time the practical possibility, to achieve this task. Even large amounts can be produced easily and space saving without the manipulation of pots and pans or the blocking of the kitchen range.

By using a lower temperature as in the "Steaming" mode, a whole range of raw materials receives an improvement of their typical own taste, intensified colour and a specific food related cooking.

## Cooking times in the "Vario-Steaming" mode:

During the traditional preparation (bain marie/ casseroles) the cook paid more attention to the cooking temperature than to the actual cooking time. The same principle applies for the "Vario-Steaming" mode. As recommendations of approximate cooking times you can use the chart of the "Steaming" mode (see pages 28–43).

Generally for the "Vario-Steaming" mode you have to observe:

The lower the cooking temperature, the longer the cooking time.

## Recommendations of cooking temperatures in the "Vario-Steaming" mode

**Soup trimmings:** 75°–90° C

**Fisch, crustaceans:** 75°–90° C

**Pies, galantines, patés:** 65°–90° C

**Sausages:** 72°–75° C

**White meat:** 75°–85° C

**Dark meat:** 80°–90° C

**Poultry:** 80° C

**Desserts:** 65°–90° C

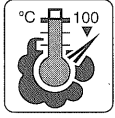

# Vario-steaming mode

= Moist Heat in the low temperature range between 30°–99°C

## Cooking in vacuum

The development of cooking in vacuum was based on the method of vacuum preserving. The most important requirement for the cooking in vacuum is, that the raw material is absolut 100% vacuum-packed. The cooking item is sealed in special sealing and/or vacuum bags. After the cooking in vacuum the products are cooled down quickly to + 2° C.

As recommendations for cooking times see the cooking times in the "Steaming" mode chart.

### Practical findings:

The better vacuumed (complete vacuum), the shorter the cooking time.

### Application methods:

Fish, meat, poultry, vegetable, side dishes and fruits are to be prepared the conventional way. Different garnishes and special stuffings can be prepared with special attention.

For the cooking in vacuum place the food items on to the grids!

### **Cooking in vacuum:**

**Fish, stuffings, goose liver:** 70° C

**White meat:** 80° C

**Vegetable, mushrooms, fruits:** 90° C

**Dark meat, side dishes:** 100° C

### **Scalding:**

In the RATIONAL Combi-Steamer CM the scalding is especially gentle and will be used mainly for the production of sausages.

### **Advantages compared with the cooking in kettles**

- Firm structure of stuffings
- Intensified aroma and intensified taste of the products
- When processing fat material, the weight loss is very low
- Bursts are avoided, especially when using skins with damaged surfaces

**Recommended approximate temperature:**

**72° C – 80° C**

### **Preserving:**

The cooking temperature depends on the type of the product (grade of ripeness, cut). According to the firmness of the raw material and the desired preserving result, the cooking item will be covered with hot or cold water. The diameter of the used preserving containers (jars) should not exceed 100 to 120 mm.

**Recommended approximate temperature:**

**74° – 100° C.**

## Application instructions

### **and advice:**

The use of differently sized GN-containers depend on the individual amount and size of the equivalent cooking item. Perforated and unperforated containers can be used individually according to the cooking method.

In addition all sorts of forms can be used, such as ramekins, ring tins, pie trays etc. The material (glass, clay, porcelain, chrome-nickel-steel) is of no importance. The forms are placed on grids or shallow GN-containers (20 mm).

### **Seasoning:**

Simply by choosing a lower cooking temperature, the typical own taste is intensified. Therefore, quite a number of products do not need any more taste improving seasonings, especially salting! Measure the added alcohol and the use of different fumets, essences etc. carefully. Season the dishes individually.

## Notes

---

---

---

---

---

---

---

---

---

---



## Operating mode

# Reheating

### Instead of heating up and keeping food warm

#### Starting up :

**Preheating :**  +  + 

Preheat the RATIONAL Combi-Steamer CM until the selected reheat temperature is reached.

#### Advantages :

In the reheating program the humidity of the interior of the RATIONAL Combi-Steamer CM is automatically adapted to your reheating requirements on plates and platters by an electronically controlled steam supply. Thus an ideal environment is created, preventing products that were arranged on the plates beforehand (in a cold state) from leaving dry rims or unwanted puddles (of condensed water).

The cooking time and the temperature are set individually, according to the product being processed, and setting high quality standards. The preset values are shown as actual values on the digital displays.

#### Temperature selection range :

30° - 300° C

## Instructions for use and hints

### Loading

Open the door and introduce the portioned cold plates on grids with the mobile oven racks and transport trolley (for tabletop models) and the transport trolleys (for floor models).

For **servicing platters up to 375 mm** use the **RATIONAL Special Transport Trolley**.

### Reheating time :

Set to approx. 5 - 8 minutes. Reheating time varies according to product, product temperature, number of plates/platters and load.

### Reheating temperature :

Generally, temperatures between **140°** and **160° C** have given the best results, but the temperature can be set individually according to the consistency of the product to be processed.

### Some advice for the use of this mode :

For quick and thorough reheating of the foods, make note of the following items :

- Arrange/spread the components of the meals evenly on the plates and/or platters.
- Sauces/Gravies : Always cover or pour over the product or pour a small amount on the plate after reheating.

- Large components like, for instance, potato dumplings and other convenience products, beef rolls, turkey legs, pork leg, soufflé (65 mm), etc., require more time to heat up than ready-cut roast beef, portioned poultry, vegetable side dishes, rice, pastry on serving china, quartered potatoes, various fruits and precooked food.

A very good idea for smooth operations with reheating/warming up is to make tests of the different products/combinations in order to find the ideal conditions for reheating and write reports for future reference.

- The possibility of using the core temperature probe any time you wish to determine the ideal serving temperature represents the highest degree of safety.
- For variable reheating in any other operating mode please refer to page 21.







## Cooking with core temperature (meat probe)

1. Introduce the clean and cold temperature probe tip into the thickest part of the food item.
2. Set the mode switch ⑥ to "Steaming" ⑦, "Hot Air" ⑧, "Combi-Steamer" ⑨, "Vario-Steamer" ⑩ or "Reheat" ⑪ (the buzzer comes on).
3. Preselect the desired core temperature with the core temperature selection switch ⑫ (buzzer stops). The display ⑬ shows the preselected core temperature. The core temperature display ⑭ shows the actual core temperature. The core temperature indicator light ⑮ signals that the meat probe is in operation.
4. Set the temperature selection switch ⑯ in a clockwise direction to the desired cooking temperature (not working in the "Steaming" mode). The display ⑰ shows the preselected cooking temperature.
5. The timer ⑱ remains at ●.
6. The cooking process is operating automatically.
7. When the preselected core temperature is reached, the buzzer sounds. The unit is switched off automatically.
8. During the cooking process the preselected cooking temperature as well as the preselected mode can be altered at any time.
9. The unit is switched off completely by setting all switches to ●.
10. If a higher core temperature is desired, once the preselected one is reached, the core temperature selection switch ⑲ is to be set to ● first, then the new core temperature ⑳ can be selected.

### Core temperature measurement

The possibility to measure the core temperature of big roasts is very advantageous. Especially in cases of cooking items, that need a lot of care and control, such as roastbeef etc. it is essential to achieve the precise core temperature.

Practise shows, that consequent working with the meat probe results in lower weight losses. Every degree exceeding the optimal core temperature means a substantially higher weight loss. In addition, a constantly equal cooking result helps you to guarantee a high quality standard, especially where meat is concerned.

The following chart will show you some indications of core temperatures.

### General information concerning core temperature for meat

Meat	Core temperature	Colour of meat core
<b>Beef</b>		
Rare	15°C	dark blood red
Medium rare	50°C	red meat blood red juice
Medium	55 - 60°C	light pink fading into greyish-brown towards the outside
Well done	75 - 85°C	uniformly grey-brown throughout
<b>Veal</b>		
Fully cooked	over 77°C	reddish-brown greyish-white meat juice
<b>Pork</b>		
Medium	65°C	light pink
Fully cooked	75 - 80°C	yellowish-brown greyish-white meat juice
Pickled	65°C	pale red brownish or nearly colour- less juice
<b>Lamb</b>		
Fully cooked	79°C	grey, lightly pale red
<b>Mutton</b>		
Fully cooked	82°C	grey, lightly pale red juice
<b>Poultry</b>		
Fully cooked	85°C	yellowish-white nearly colour- less juice



## Cooking with core temperature (meat probe)

### Core temperature values

	State	Core temperature
<b>Beef</b>		
Fillet of Beef	medium	55–58°C / 130–135° F
Roastbeef	medium	55–60°C / 130–140° F
Beef Rose	well done	85–90°C / 185–195° F
Roast Beef Joint	well done	80–85°C / 175–185° F
Aitchbone	well done	90°C / 195° F

### Pork

Leg	well done	75°C / 165° F
Leg	underdone	65–68°C / 150–155° F
Saddle	just right	65–70°C / 150–158° F
Pork neck	well done	70–75°C / 158–165° F
Pork shoulder	well done	75°C / 165° F
Belly/stuffed	well done	70–75°C / 158–165° F
Knuckle, roasted	well done	80–85°C / 175–185° F
Ham	juicy	64–68°C / 145–155° F
Smoked pork chops (Mixed cold meat-buffet)		65–70°C / 150–158° F
Ribs	well done	65°C / 150° F
Ham (in bread crust)		65–70°C / 150–158° F
Tongue	well done	85–90°C / 185–195° F
Pig's Head		75–82°C / 165–180° F

### Veal

Saddle of veal	just right	65–70°C / 150–158° F
Leg, Top-side, Fricandeau	well done	78°C / 172° F
Loin of veal	well done	75–80°C / 165–175° F
Roast/Shoulder	well done	75–80°C / 165–175° F
Breast (often stuffed or boned)	well done	75–78°C / 165–170° F

	State	Core temperature
<b>Mutton</b>		
Saddle	just right	70–75°C / 158–165° F
Saddle	well done	80°C / 175° F
Leg	just right	75–78°C / 165–170° F
Leg	well done	82–85°C / 180–185° F

### Lamb

When the meat is well done, the core temperature varies between 79° to 85°C (173–185°F). The colour of the core is grey, slightly pink. The gravy is clear.

### Poultry

Chicken	well done	85°C / 185° F
Goose	just right	75–80°C / 165–175° F
Goose	well done	90–92°C / 195–198° F
Turkey, Duck	well done	80–85°C / 175–185° F

### Pies, Pates etc.

Pies		72–74°C / 160–165° F
Meat Puddings		70°C / 158° F

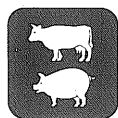

## Examples Beef, veal and pork

Food	State	Hints and Advices	Proper GN-container/ grid	Amount per container/ grid
<b>Fillet Steak</b>	fresh, approx. 3 cm high, medium	season, oil lightly	1/1 grid	12 pcs.
<b>Sirloin Steak</b>	fresh, approx. 2 cm high, medium	season, oil lightly don't flatten	1/1 grid	10 pcs.
<b>Scallops</b>	fresh, approx. 130 g	season, oil lightly	1/1 grid	10 pcs.
<b>Pork Chops</b>	fresh	rub in seasoning well, don't flatten	1/1 grid	10 pcs.
<b>Beef liver</b>	portioned	cut in equal slices	1/1 grid 20 mm granit.	10 pcs.
<b>Roastbeef</b>		season, oil lightly	1/1 grid 20 mm granit.	6 kg
<b>Beef joint</b>	mature	choose flat pieces ø 80–100 mm	1/1 grid 65 mm unperf.	6–8 kg
<b>Veal joint</b>	tie if necessary	season, lard lean parts (fricandeau)	1/1 grid 65 mm unperf.	8 kg
<b>Pork neck Pork roast</b>	boned	season well, use spice mixture	1/1 grid 65 mm unperf.	8 kg
<b>Dark meat</b>	fresh	add "bouquet garni" if necessary	65 mm unperf.	6–8 kg
<b>Fricassée of veal</b>	fresh	add spices and vegetable to the meat	65 mm unperf.	3–4 kg
<b>White Meat</b>	fresh	add "bouquet garni" if necessary	65 mm unperf.	6–8 kg
<b>Salted and Smoked Neck</b>	fresh	boned, place similar sized pieces on same grid	1/1 grid	6–8 kg
<b>Pork Knuckle</b>	fresh		1/1 grid 65 mm unperf.	7–9 pcs.
<b>Pork Leg</b>	fresh 900–1200 g	steam first, cut the crackling, season, don't oil	1/1 grid	6–8 pcs.
<b>Hamburger</b>	fresh	oil lightly if necessary preheat to 300°C	20 mm granit.	10–12 pcs.
<b>Meat Loaf Minced Meat</b>	fresh, approx. 2 kg per form	smooth surface, possibly fill in forms	40 mm granit.	6 kg
<b>Beef Rolls</b>	convenience fast food	season, add some red wine	65 mm unperf.	20–25 pcs.
<b>Ragout Fin</b>	gratinate	fill the warm ragout fin in forms cover with sauce hollandaise	1/1 grid	gratinate acc. to size
<b>Meat Pudding</b>	fresh, approx. 2 kg	fill in aluminium containers	1/1 grid	4–6 kg

## CM 6, CM 101

Accessories per load		Mode switch	Temp. °C °F	Cooking time in min.	Approximate load capacity		Approximate amount per hour	
CM 6	CM 101				CM 6	CM 101	CM 6	CM 101
6 x 1/1 grid	10 x 1/1 grid		250–270 480–515	7	72 pcs.	120 pcs.	432 pcs.	720 pcs.
6 x 1/1 grid	10 x 1/1 grid		250–270 480–515	8–10	60 pcs.	100 pcs.	360 pcs.	600 pcs.
6 x 1/1 grid	10 x 1/1 grid		250 480	10	60 pcs.	100 pcs.	300 pcs.	500 pcs.
6 x 1/1 grid	10 x 1/1 grid		250–270 480–515	15	60 pcs.	100 pcs.	240 pcs.	400 pcs.
6 x 1/1 grid 6 x 20mm	10 x 1/1 grid 10 x 20 mm		250 480	10	60 pcs.	100 pcs.	360 pcs.	600 pcs.
3 x 1/1 grid 3 x 20mm	5 x 1/1 grid 5 x 20 mm		140–200 390	25–30	18 kg	30 kg	36 kg	60 kg
2 x 1/1 grid 1 x 65 mm	4 x 1/1 grid 1 x 65 mm		140–160 285–320	90–120	20 kg	30 kg		
2 x 1/1 grid 1 x 65 mm	4 x 1/1 grid 1 x 65 mm		160–180	90–100	20 kg	30 kg		
2 x 1/1 grid 1 x 65 mm	4 x 1/1 grid 1 x 65 mm		160–180 320–355	85–100	20 kg	40 kg		
3 x 65 mm	5 x 65 mm		80 175		20 kg	40 kg		
3 x 65 mm	5 x 65 mm		75–85 165–185		12 kg	20 kg		
3 x 65 mm	5 x 65 mm		80 175		20 kg approx.	40 kg approx.		
3 x 1/1 grid	5 x 1/1 grid			50	20 kg	35–40 kg		
3 x 1/1 grid 3 x 65 mm	5 x 1/1 grid 5 x 65 mm			70–100	21–27 pcs.	35–45 pcs.		
3 x 40mm	5 x 40 mm		180 355	70	18 pcs.	30 pcs.		
6 x 20mm	10 x 20 mm		230 445	15	60 pcs.	120 pcs.	240 pcs.	480 pcs.
3 x 1/1 grid	5 x 1/1 grid		150–170 305–335	90	18 kg	30 kg		
3 x 65 mm	5 x 65 mm		160–180 320–355	70	75 pcs.	125 pcs.		
3 x 1/1 grid	5 x 1/1 grid		250 480	6	according to size			
3 x 1/1 grid	5 x 1/1 grid		130–160 280–320	90	18 kg	30 kg		

Food are natural products. Therefore the indicated values for temperature and time may only be seen as approximate standard values.



## Examples Beef, veal and pork

Food	State	Hints and Advices	Proper GN-container/grid 1/1 GN or 2/1 GN	Amount per container/ grid
<b>Fillet Steak</b>	fresh, approx. 3 cm high, medium	season, oil lightly	grid	$\frac{1}{1}$ GN 12 pcs. $\frac{2}{1}$ GN 24 pcs.
<b>Sirloin Steak</b>	fresh, approx. 2 cm high, medium	season, oil lightly don't flatten	grid	$\frac{1}{1}$ GN 10 pcs. $\frac{2}{1}$ GN 20 pcs.
<b>Scallops</b>	fresh, approx. 130g	season, oil lightly	grid	$\frac{1}{1}$ GN 10 pcs. $\frac{2}{1}$ GN 20 pcs.
<b>Pork Chops</b>	fresh	rub in seasoning well, don't flatten	grid	$\frac{1}{1}$ GN 10 pcs. $\frac{2}{1}$ GN 20 pcs.
<b>Beef liver</b>	portioned	cut in equal slices	grid 20 mm granit.	$\frac{1}{1}$ GN 10 pcs. $\frac{2}{1}$ GN 20 pcs.
<b>Roastbeef</b>		season, oil lightly	grid 20 mm granit.	$\frac{1}{1}$ GN 6 kg $\frac{2}{1}$ GN 12 kg
<b>Beef joint</b>	mature	choose flat pieces Ø 80–100 mm	grid 65 mm unperf.	$\frac{1}{1}$ GN 6-8 kg $\frac{2}{1}$ GN 12-16 kg
<b>Veal joint</b>	tie if necessary	season, lard lean parts (fricandeau)	grid 65 mm unperf.	$\frac{1}{1}$ GN 8 kg $\frac{2}{1}$ GN 16 kg
<b>Pork neck Pork roast</b>	boned	season well, use spice mixture	grid 65 mm unperf.	$\frac{1}{1}$ GN 8 kg $\frac{2}{1}$ GN 16 kg
<b>Dark meat</b>	fresh	add "bouquet garni" if necessary	65 mm unperf.	$\frac{1}{1}$ GN 6-8 kg $\frac{2}{1}$ GN 12-16 kg
<b>Fricassée of veal</b>	fresh	add spices and vegetable to the meat	65 mm unperf.	$\frac{1}{1}$ GN 3-4 kg $\frac{2}{1}$ GN 6-8 kg
<b>White Meat</b>	fresh	add "bouquet garni" if necessary	65 mm unperf.	$\frac{1}{1}$ GN 6-8 kg $\frac{2}{1}$ GN 12-16 kg
<b>Salted and Smoked Neck</b>	fresh	boned, place similar sized pieces on same grid	grid	$\frac{1}{1}$ GN 6-8 kg $\frac{2}{1}$ GN 12-16 kg
<b>Pork Knuckle</b>	fresh		grid 65 mm unperf.	$\frac{1}{1}$ GN 7-9 pcs. $\frac{2}{1}$ GN 14-18 pcs.
<b>Pork Leg</b>	fresh 900–1200g	steam first, cut the crackling, season, don't oil	grid	$\frac{1}{1}$ GN 6-8 pcs. $\frac{2}{1}$ GN 12-16 pcs.
<b>Hamburger</b>	fresh	oil lightly if necessary preheat to 300°C	20 mm granit.	$\frac{1}{1}$ GN 10-12 pcs. $\frac{2}{1}$ GN 20-24 pcs.
<b>Meat Loaf Minced Meat</b>	fresh, approx. 2 kg per form	smooth surface, possibly fill in forms	40 mm granit.	$\frac{1}{1}$ GN 6 kg $\frac{2}{1}$ GN 12 kg
<b>Beef Rolls</b>	convenience fast food	season, add some red wine	65 mm unperf.	$\frac{1}{1}$ GN 20-25 pcs. $\frac{2}{1}$ GN 40-24 pcs.
<b>Ragout Fin</b>	gratinate	fill the warm ragout fin in forms cover with sauce hollandaise	grid	gratinate acc. to size
<b>Meat Pudding</b>	fresh, approx. 2 kg	fill in aluminium containers	grid	$\frac{1}{1}$ GN 4-6 kg $\frac{2}{1}$ GN 8-12 kg

# CM 201, CM 20

Accessories per load		Mode switch	Temp. °C °F	Cooking time in min.	Approximate load capacity		Approximate amount per hour	
CM 201	CM 20				CM 201	CM 20	CM 201	CM 20
20 x 1/1 grid	20 x 2/1 grid		250-270 480-515	7	240 pcs.	480 pcs.	1440 pcs.	2880 pcs.
20 x 1/1 grid	20 x 2/1 grid		250-270 480-515	8-10	200 pcs.	400 pcs.	1200 pcs.	2400 pcs.
20 x 1/1 grid	20 x 2/1 grid		250 480	10	200 pcs.	400 pcs.	1000 pcs.	2000 pcs.
20 x 1/1 grid	20 x 2/1 grid		250-270 480-515	15	200 pcs.	400 pcs.	800 pcs.	1600 pcs.
20 x 1/1 grid 20 x 20mm	20 x 2/1 grid 20 x 20mm		250 480	10	200 pcs.	400 pcs.	1200 pcs.	2400 pcs.
10 x 1/1 grid 10 x 20mm	10 x 2/1 grid 10 x 20mm		140-200 390	25-30	60 kg	120 kg	120 kg	240 kg
9 x 1/1 grid 1 x 65mm	9 x 2/1 grid 1 x 65mm		140-160 295-390	90-120	80 kg	160kg		
9 x 1/1 grid 1 x 65mm	9 x 2/1 grid 1 x 65mm		160-180 320-355	90-100	60 kg	120 kg		
9 x 1/1 grid 1 x 65mm	9 x 2/1 grid 1 x 65mm		160-180 320-355	85-100	70 kg	140 kg		
10 x 65mm	10 x 65mm		80 175		80 kg approx.	160 kg approx.		
10 x 65mm	10 x 65mm		75-85 165-175		40 kg	80 kg		
10 x 65mm	10 x 65mm		80 175		80 kg approx.	160 kg approx.		
10 x 1/1 grid	10 x 2/1 grid			50	80 kg	160 kg		
10 x 1/1 grid 10 x 65mm	10 x 2/1 grid 10 x 65mm			70-100	70-90 pcs.	140-180 pcs.		
10 x 40mm	10 x 40mm		180 355	70	80 pcs.	160 pcs.		
20 x 20mm	20 x 20mm		230 445	15	240 pcs.	480 pcs.	960 pcs.	1920 pcs.
10 x 1/1 grid	10 x 2/1 grid		150-170 305-335	90	60 kg	120 kg		
10 x 65mm	10 x 65mm		160-180 320-355	70	250 pcs.	500 pcs.		
10 x 1/1 grid	10 x 2/1 grid		250 480	6	according to size			
10 x 1/1 grid	10 x 2/1 grid		130-160 280-320	90	60 kg	120 kg		

Food are natural products. Therefore the indicated values for temperature and time may only be seen as approximate standard values.



## Examples Game, poultry, pies, fish, crustaceans

Food	State	Hints and Advices	Proper GN-container/ grid	Amount per container/ grid	A
English Ham		Let the baker wrap it in bread dough	20 mm or 40 mm granit.	according to size	
Whole Ham	fresh	slightly cured, add some cloves	1/1 grid	1	1
Saddle of Hare	fresh larded	season, wrap with bacon or oil slightly	20mm unperf. or 1/1 grid	6–8 pcs.	3
Saddle of Venison	fresh larded	skewer spine, season, oil	20mm unperf. or 1/1 grid	2 pcs.	3
Leg of Venison	fresh larded	season, bond, tie	1/1 grid 1/1, 65 mm unperf.	5–6 kg	3
Larded leg of hare		season	1/1, 65 mm unperf.	12 pcs.	3
Whole Chicken	fresh or thawed approx. 1000 g	dry well, rub in seasoning well, oil	1/1 grid	6 pcs.	3
Chicken Legs	fresh or thawed	brush with liquid seasoning or oil mixture	1/1 grid	10–12 pcs.	6
Goose	fresh	season, possibly stuff, don't oil	1/1 grid 40 mm granit.	2 pcs.	1
Turkey	fresh	season, possibly lard	1/1 grid 40 mm granit.	2 pcs.	1
Duck breast vacuum cooked	fresh	boned, roast well, vacuum well	1/1 grid	10 pcs.	6
Poultry	fresh		20/40 or 65 mm	6 kg	3
Leg of Lamb	boned tied	season, possibly stuff, don't oil	1/1 grid	6–7 kg	3
Leg of Lamb vacuum cooked	fresh	bone, observe exact vacuum, season acc. to preparation	1/1 grid	6–7 kg	3
Home-made Sausage	fresh	stuff the skin evenly, don't bind too tight	20 mm 1/1 grid	approx. 30 pcs.	6
			20 mm	50 pcs.	6
Paté à la Maison	fresh	fill the forms well	pie trays/ paté forms	6–8 kg	3
Perch	fresh	season, possibly with wine or court-bouillon	40 mm unperforated	10–12 pcs.	6
Trout au bleu	fresh	bend out belly-lobes	20 or 40 mm unperforated	8–10 pcs.	3
Sole rolls	fresh	season, add wine, roll with the skin to the outside	40 mm unperforated	30 pcs.	6
Flounders	fresh	cook with the pale bottom side up	20 mm granit.	4–5 pcs.	6
Fried Trout	fresh	season, oil slightly	20 mm granit.	8–10 pcs.	3
Salmon Trout Salmon Steak	fresh	natural, prepare in serving dishes with fumets	20 mm 1/1 grid	approx. 20/15 pcs.	6
Mussels	fresh	when adding julienne, blanch shortly	40 or 65 mm	1–2 kg approx.	6
Salmon Soufflée	fresh	observe the material of the used forms	cocottes, pie trays, forms	10–20 forms	3



# CM 6, CM 101

Accessories per load		Mode switch	Temp. °C °F	Cooking time in min.	Approximate load capacity		Approximate amount per hour	
CM 6	CM 101				CM 6	CM 101	CM 6	CM 101
	2 x 1/1 grid 1 x 65 mm	 	170 340	90–120	according to size and height of the cooking item			
1 x 1/1 grid 1 x 65 mm	5 x 1/1 grid 5 x 20 mm		140 295	180	1 piece	possibly 2 pieces		
3 x 1/1 grid 3 x 20 mm	5 x 1/1 grid 5 x 20 mm		220 430	15–20	24 pcs.	40 pcs.	70 pcs.	120 pcs.
3 x 1/1 grid 3 x 20 mm	5 x 1/1 grid 5 x 65 mm		220 430	25	6 pcs.	10 pcs.	12 pcs.	20 pcs.
3 x 1/1 grid 3 x 20 mm	5 x 65 mm	  	160–180 320–355	60–70	15 kg	30 kg		
3 x 65 mm	5 x 1/1 grid		180 355	45	36 pcs.	60 pcs.		
3 x 1/1 grid	10 x 1/1 grid		220 430	35	18 pcs.	30 pcs.	36 pcs.	60 pcs.
6 x 1/1 grid	3 x 1/1 grid 3 x 40 mm		220 430	18	70 pcs.	120 pcs.	210 pcs.	360 pcs.
1 x 1/1 grid 1 x 40 mm	3 x 1/1 grid 3 x 40 mm	  	170 340	100–120	4 pcs.	6 pcs.		
1 x 1/1 grid 1 x 40 mm	10 x 1/1 grid	  	180 355	90–110	4 pcs.	6 pcs.		
6 x 1/1 grid	5 x 1/1 grid		70 155		60 pcs.	100 pcs.		
3 x 1/1 grid	5 x 1/1 grid		85 175		18 kg	30 kg		
3 x 1/1 grid	5 x 1/1 grid	  	160–180 320–355	70–80	20 kg	40 kg		
3 x 1/1 grid	10 x 20 mm		70 155		20 kg	60 kg		
6 x 20 mm	10 x 20 mm		72 158		180 pcs. approx.	300 pcs. approx.		
6 x 20 mm	5 x 1/1 grid		80 175		300 pcs.	500 pcs.		
3 x 1/1 grid	10 x 40 mm		79 172		20 kg	40 kg		
6 x 40 mm	5 x 20 mm 5 x 40 mm			10–15	60 pcs.	120 pcs.	240 pcs.	480 pcs.
3 x 20 mm 3 x 40 mm	10 x 40 mm			10–15	24–30 pcs.	40–50 pcs.	70–90 pcs.	120–150 pcs.
6 x 40 mm	10 x 20 mm		75 163		180 pcs.	300 pcs.		
6 x 20 mm	5 x 20 mm		250 480	15	24–30 pcs.	40–50 pcs.	70–90 pcs.	120–150 pcs.
3 x 20 mm	10 x 20 mm		250 480	15	24–30 pcs.	40–50 pcs.	70–90 pcs.	120–150 pcs.
6 x 20 mm	10 x 40 mm 5 x 65 mm				120–90 pcs. approx.	150–200 pcs. approx.		
6 x 40 mm 3 x 65 mm	5 x 1/1 grid		78 170		6 kg	10 kg		
3 x 1/1 grid			75 163		60 forms	100 forms		



## Examples Game, poultry, pies, fish, crustaceans

Food	State	Hints and Advices	Proper GN-container/grid 1/1 GN or 2/1 GN	Amount per container/ grid
English Ham		Let the baker wrap it in bread dough	20 mm or 40 mm granit.	$\frac{1}{1}$ GN according to size $\frac{2}{1}$ GN
Whole Ham	fresh	slightly cured, add some cloves	grid	$\frac{1}{1}$ GN 1 pcs. $\frac{2}{1}$ GN 2 pcs.
Saddle of Hare	fresh larded	season, wrap with bacon or oil slightly	20 mm unperf. or grid	$\frac{1}{1}$ GN 6-8 pcs. $\frac{2}{1}$ GN 12-16 pcs.
Saddle of Venison	fresh larded	skewer spine, season, oil	20 mm unperf. or grid	$\frac{1}{1}$ GN 2 pcs. $\frac{2}{1}$ GN 4 pcs.
Leg of Venison	fresh larded	season, bond, tie	grid 65 mm unperf.	$\frac{1}{1}$ GN 5-6 kg $\frac{2}{1}$ GN 10-12 kg
Larded leg of hare		season	65 mm unperf.	$\frac{1}{1}$ GN 12 pcs. $\frac{2}{1}$ GN 24 pcs.
Whole Chicken	fresh or thawed approx. 1000 g	dry well, rub in seasoning well, oil	grid	$\frac{1}{1}$ GN 6 pcs. $\frac{2}{1}$ GN 12 pcs.
Chicken Legs	fresh or thawed	brush with liquid seasoning or oil mixture	grid	$\frac{1}{1}$ GN 10-12 pcs. $\frac{2}{1}$ GN 20-24 pcs.
Goose	fresh	season, possibly stuff, don't oil	grid 40 mm granit.	$\frac{1}{1}$ GN 2 pcs. $\frac{2}{1}$ GN 4 pcs.
Turkey	fresh	season, possibly lard	grid 40 mm granit.	$\frac{1}{1}$ GN 2 pcs. $\frac{2}{1}$ GN 4 pcs.
Duck breast vacuum cooked	fresh	boned, roast well, vacuum well	grid	$\frac{1}{1}$ GN 10 pcs. $\frac{2}{1}$ GN 20 pcs.
Poultry	fresh		20/40 or 65 mm	$\frac{1}{1}$ GN 6 kg $\frac{2}{1}$ GN 12 kg
Leg of Lamb	boned tied	season, possibly stuff, don't oil	grid	$\frac{1}{1}$ GN 6-7 kg $\frac{2}{1}$ GN 12-14 kg
Leg of Lamb vacuum cooked	fresh	bone, observe exact vacuum, season acc. to preparation	grid	$\frac{1}{1}$ GN 6-7 kg $\frac{2}{1}$ GN 12-14 kg
Home-made Sausage	fresh	stuff the skin evenly, don't bind too tight	20 mm grid	approx. $\frac{1}{1}$ GN 30 pcs. $\frac{2}{1}$ GN 60 pcs.
			20 mm	$\frac{1}{1}$ GN 50 pcs. $\frac{2}{1}$ GN 100 pcs.
Paté à la Maison	fresh	fill the forms well	pie trays/ paté forms	$\frac{1}{1}$ GN 6-8 kg $\frac{2}{1}$ GN 12-16 kg
Perch	fresh	season, possibly with wine or court-bouillon	40 mm unperforated	$\frac{1}{1}$ GN 10-12 pcs. $\frac{2}{1}$ GN 20-24 pcs.
Trout au bleu	fresh	bend out belly-lobes	20 or 40 mm unperforated	$\frac{1}{1}$ GN 8-10 pcs. $\frac{2}{1}$ GN 16-20 pcs.
Sole rolls	fresh	season, add wine, roll with the skin to the outside	40 mm unperforated	$\frac{1}{1}$ GN 30 pcs. $\frac{2}{1}$ GN 60 pcs.
Flounders	fresh	cook with the pale bottom side up	20 mm granit.	$\frac{1}{1}$ GN 4-5 pcs. $\frac{2}{1}$ GN 8-10 pcs.
Fried Trout	fresh	season, oil slightly	20 mm granit.	$\frac{1}{1}$ GN 8-10 pcs. $\frac{2}{1}$ GN 16-20 pcs.
Salmon Trout Salmon Steak	fresh	natural, prepare in serving dishes with fumets	20 mm grid	approx. $\frac{1}{1}$ GN 20 pcs. $\frac{2}{1}$ GN 40 pcs.
Mussels	fresh	when adding julienne, blanch shortly	40 or 65 mm	approx. $\frac{1}{1}$ GN 1-2 kg $\frac{2}{1}$ GN 2-4 kg
Salmon Soufflée	fresh	observe the material of the used forms	cocottes, pie trays, forms	$\frac{1}{1}$ GN 10-20 forms $\frac{2}{1}$ GN 20-40 forms

# CM 201, CM 20

Accessories per load		Mode switch	Temp. °C °F	Cooking time in min.	Approximate load capacity		Approximate amount per hour	
CM 201	CM 20				CM 201	CM 20	CM 201	CM 20
			170 340	90-120	according to size and height of the cooking item			
5 x 1/4 grid 1 x 65 mm	5 x 2/4 grid 1 x 65 mm		140 295	180	5 pcs.	10 pcs.		
10 x 1/4 grid 10 x 20 mm	10 x 2/4 grid 10 x 20 mm		220 430	15-20	80 pcs.	160 pcs.	400 pcs.	800 pcs.
10 x 1/4 grid 10 x 20 mm	10 x 2/4 grid 10 x 20 mm		220 430	25	20 pcs.	40 pcs.	40 pcs.	80 pcs.
10 x 1/4 grid 10 x 20 mm	10 x 2/4 grid 10 x 20 mm		160-180 320-355	60-70	60 kg	120 kg		
10 x 65 mm	10 x 65 mm		180 355	45	120 pcs.	240 pcs.		
10 x 1/4 grid	10 x 2/4 grid		220 430	35	60 pcs.	120 pcs.	120 pcs.	240 pcs.
20 x 1/4 grid	20 x 2/4 grid		220 430	18	240 pcs.	480 pcs.	720 pcs.	1440 pcs.
6 x 1/4 grid 6 x 40 mm	6 x 2/4 grid 6 x 40 mm		170 340	100-120	12 pcs.	24 pcs.		
6 x 1/4 grid 6 x 40 mm	6 x 2/4 grid 6 x 40 mm		180 355	90-110	12 pcs.	24 pcs.		
20 x 1/4 grid	20 x 2/4 grid		70 155		200 pcs.	400 pcs.		
10 x 1/4 grid	10 x 2/4 grid		85 175		60 kg	120 kg		
10 x 1/4 grid	10 x 2/4 grid		160-180 320-355	70-80	70 kg	140 kg		
10 x 1/4 grid	10 x 2/4 grid		70 155		60 kg approx.	120 kg approx.		
20 x 20 mm	20 x 20 mm		72 158		600 pcs. approx.	1200 pcs. approx.		
20 x 20 mm	20 x 20 mm		80 175		1000 pcs.	2000 pcs.		
10 x 1/4 grid	10 x 2/4 grid		79 172		80 kg according to size	160 kg according to size		
20 x 40 mm	20 x 40 mm			10-15	240 pcs.	480 pcs.	960 pcs.	1920 pcs.
10 x 20 mm 10 x 40 mm	10 x 20 mm 10 x 40 mm			10-15	80-100 pcs.	160-200 pieces	400-500 pieces	800-1000 pieces
20 x 40 mm	20 x 40 mm		75 163		600 pcs.	1200 pcs.		
20 x 20 mm	20 x 20 mm		250 480	15	80-100 pcs.	160-200 pieces	320-400 pcs.	640-800 pcs.
10 x 20 mm	10 x 20 mm		250 480	15	80-100 pcs.	160-200 pieces	320-400 pcs.	640-800 pcs.
20 x 20 mm	20 x 20 mm				approx. 400 pcs. 300 pcs.	approx. 800 pcs. 600 pcs.		
20 x 40 mm 10 x 65 mm	20 x 40 mm 10 x 65 mm		78 170		20 kg approx.	40 kg approx.		
10 x 1/4 grid	10 x 2/4 grid		75 163		200 forms	400 forms		



## Examples Vegetable, side dishes

Food	State	Hints and Advices	Proper GN-container/ grid	Amount per container/ grid
<b>Cauliflower</b>	fresh	quartered, remove or crosscut stalks	65 mm unperf. or perforated	approx. 4 heads
<b>Brussels Sprouts</b>	frozen	season while frozen, add butter just before serving	65 mm unperf. or perforated	3–4 kg
<b>Broccoli</b>	frozen	season while frozen, add butter just before serving	65 mm unperf. or perforated	3–4 kg
<b>French Carrots</b>	frozen	season while frozen, add butter just before serving	65 mm unperf. or perforated	3–4 kg
<b>Mushrooms</b>	fresh	sprinkle with lemon juice before processing	65 mm unperf.	2 kg
<b>Spinach</b>	fresh		65 mm perforated	2 kg
<b>Asparagus</b>	fresh	sprinkle with lemon juice before processing	40 or 65 mm unperforated	2 kg
<b>Vegetable Plates</b>	prepared	glaze just before serving	1/1 grid or 20mm	4 pcs.
<b>Gratinated Cauliflower</b>	precooked	use every second rail	1/1 grid	30 port.
<b>Cabbage rolls</b>	fresh	cook cabbage leaves well, possibly wrap with bacon	65 mm unperf.	25 pcs.
<b>Stuffed peppers</b>	fresh	place in containers with the opening downwards	65 mm unperf.	20 pcs.
<b>Vegetable Preserves</b>	fresh or frozen	observe diameter of jars and tins	40 or 65 mm perf. or unperforated	3–4 kg
<b>Potatoes</b>	fresh	Quarter by the width, salt evenly	95 or 105 mm perforated	8–14 kg
<b>Rice</b>	Longgrain Parboiled	water, stock or broth: Rice proportion 2 : 1	65 mm unperf.	2 kg
<b>Dumplings</b>	Convenience-Product	Observe adding of water and soaking time, see instructions on pack.	20 mm unperf.	30 pcs.
<b>Noodles (reheated)</b>	prepared	add liquid butter or similar just before serving	65 mm unperf.	25 port.
<b>Eggs</b>		Set timer only after the window is misted over, no pricking	65–95 mm perforated	50–100 pcs.
<b>Egg Royale</b>	fresh		40 or 65 mm unperforated	3–5 l
<b>Fried Potatoes</b>	precooked	Cube, season, possibly add bacon, scatter in container	20 mm granit. 40 mm granit.	1–2 kg
<b>Baked Potatoes</b>	200 g	Wrap in aluminium foil	1/1 grid	18 pcs.

## CM 6, CM 101

Accessories per load		Mode switch	Temp. °C °F	Cooking time in min.	Approximate load capacity		Approximate amount per hour	
CM 6	CM 101				CM 6	CM 101	CM 6	CM 101
3 x 65 mm	5 x 65 mm			18	6–8 kg	13–15 kg	18–24 kg	39–45 kg
3 x 65 mm	5 x 65 mm			15–18	12 kg	20 kg	36 kg	60 kg
3 x 65 mm	5 x 65 mm			15–20	10 kg	20 kg	30 kg	60 kg
3 x 65 mm	5 x 65 mm			20	10 kg	20 kg	30 kg	60 kg
3 x 65 mm	5 x 65 mm			12	6 kg	10 kg	30 kg	60 kg
3 x 65 mm	5 x 65 mm			8	6 kg	10 kg	42 kg	70 kg
6 x 40 mm 3 x 65 mm	10 x 40 mm 5 x 65 mm			15	12 kg	20 kg	48 kg	80 kg
6 x 1/1 grid 6 x 20 mm	10 x 1/1 grid 10 x 20 mm			10	24 pcs.	40 pcs.	120 pcs.	200 pcs.
3 x 20 mm	5 x 20 mm		250 480	6	90 port.	150 port.	720 port.	1200 port.
3 x 65 mm	5 x 65 mm		160–180 320–355	50	75 pcs.	125 pcs.		
3 x 65 mm	5 x 65 mm		160–180 320–355	45	60 pcs.	120 pcs.		
6 x 40 mm 3 x 65 mm	10 x 40 mm 5 x 65 mm		90		10 kg approx.	20 kg approx.		
3 x 95 mm 2 x 150 mm	3 x 150 mm			25–30	20 kg	42 kg	40 kg	84 kg
3 x 65 mm	5 x 65 mm			25	6 kg	10 kg	12 kg	20 kg
6 x 20 mm	10 x 20 mm			15	180 pcs.	300 pcs.	700 pcs.	1200 pcs.
3 x 65 mm	5 x 65 mm			10	75 port.	125 port.	375 pcs.	625 pcs.
3 x 65 mm 3 x 95 mm	5 x 65 mm 5 x 95 mm			soft 7 hard 12				
6 x 40 mm 3 x 65 mm	10 x 40 mm 5 x 65 mm		80 175		15 l approx.	25 l approx.		
6 x 20 mm 3 x 40 mm	10 x 20 mm 5 x 40 mm		230 445	15	6–12 kg	10–20 kg	32 kg	60 kg
6 x 1/1 grid	10 x 1/1 grid		180–222 355–390	30–40	100 pcs.	180 pcs.		

Food are natural products. Therefore the indicated values for temperature and time may only be seen as approximate standard values.



## Examples Vegetable, side dishes

Food	State	Hints and Advices	Proper GN-container/grid 1/1 GN or 2/1 GN	Amount per container/ grid
<b>Cauliflower</b>	fresh	quartered, remove or crosscut stalks	65 mm unperf. or perforated	approx. $\frac{1}{1}$ GN 4 heads $\frac{2}{1}$ GN 8 heads
<b>Brussels Sprouts</b>	frozen	season while frozen, add butter just before serving	65 mm unperf. or perforated	$\frac{1}{1}$ GN 3-4 kg $\frac{2}{1}$ GN 6-8 kg
<b>Broccoli</b>	frozen	season while frozen, add butter just before serving	65 mm unperf. or perforated	$\frac{1}{1}$ GN 3-4 kg $\frac{2}{1}$ GN 6-8 kg
<b>French Carrots</b>	frozen	season while frozen, add butter just before serving	65 mm unperf. or perforated	$\frac{1}{1}$ GN 3-4 kg $\frac{2}{1}$ GN 6-8 kg
<b>Mushrooms</b>	fresh	sprinkle with lemon juice before processing	65 mm unperf.	$\frac{1}{1}$ GN 2 kg $\frac{2}{1}$ GN 4 kg
<b>Spinach</b>	fresh		65 mm perforated	$\frac{1}{1}$ GN 2 kg $\frac{2}{1}$ GN 4 kg
<b>Asparagus</b>	fresh	sprinkle with lemon juice before processing	40 or 65 mm unperforated	$\frac{1}{1}$ GN 2 kg $\frac{2}{1}$ GN 4 kg
<b>Vegetable Plates</b>	prepared	glaze just before serving	grid or 20 mm	$\frac{1}{1}$ GN 4 pcs. $\frac{2}{1}$ GN 8 pcs.
<b>Gratinated Cauliflower</b>	precooked	use every second rail	grid	$\frac{1}{1}$ GN 30 pcs. $\frac{2}{1}$ GN 60 pcs.
<b>Cabbage rolls</b>	fresh	cook cabbage leaves well, possibly wrap with bacon	65 mm unperf.	$\frac{1}{1}$ GN 25 pcs. $\frac{2}{1}$ GN 50 pcs.
<b>Stuffed peppers</b>	fresh	place in containers with the opening downwards	65 mm unperf.	$\frac{1}{1}$ GN 20 pcs. $\frac{2}{1}$ GN 40 pcs.
<b>Vegetable Preserves</b>	fresh or frozen	observe diameter of jars and tins	40 or 65 mm perf. or unperforated	$\frac{1}{1}$ GN 3-4 kg $\frac{2}{1}$ GN 6-8 kg
<b>Potatoes</b>	fresh	Quarter by the width, salt evenly	95 or 105 mm perforated	$\frac{1}{1}$ GN 8-14 kg $\frac{2}{1}$ GN 16-28 kg
<b>Rice</b>	Longgrain Parboiled	water, stock or broth: Rice proportion 2 : 1	65 mm unperf.	$\frac{1}{1}$ GN 2 kg $\frac{2}{1}$ GN 4 kg
<b>Dumplings</b>	Convenience-Product	Observe adding of water and soaking time, see instructions on pack.	20 mm unperf.	$\frac{1}{1}$ GN 30 pcs. $\frac{2}{1}$ GN 60 pcs.
<b>Noodles (reheated)</b>	prepared	add liquid butter or similar just before serving	65 mm unperf.	$\frac{1}{1}$ GN 25 pcs. $\frac{2}{1}$ GN 50 pcs.
<b>Eggs</b>		Set timer only after the window is misted over, no pricking	65-95 mm perforated	$\frac{1}{1}$ GN 50-100 pcs. $\frac{2}{1}$ GN 100-200 pcs.
<b>Egg Royale</b>	fresh		40 or 65 mm unperforated	$\frac{1}{1}$ GN 3-5 l $\frac{2}{1}$ GN 6-10 l
<b>Fried Potatoes</b>	precooked	Cube, season, possibly add bacon, scatter in container	20 mm granit. 40 mm granit.	$\frac{1}{1}$ GN 1-2 kg $\frac{2}{1}$ GN 2-4 kg
<b>Baked Potatoes</b>	200 g	Wrap in aluminium foil	grid	$\frac{1}{1}$ GN 18 pcs. $\frac{2}{1}$ GN 36 pcs.

## CM 201, CM 20

Accessories per load		Mode switch	Temp. °C °F	Cooking time in min.	Approximate load capacity		Approximate amount per hour	
CM 201	CM 20				CM 201	CM 20	CM 201	CM 20
10 x 65 mm	10 x 65 mm			18	30-40 kg	60-80 kg	90-120 kg	180-240 kg
10 x 65 mm	10 x 65 mm			15-18	40 kg	80 kg	120 kg	240 kg
10 x 65 mm	10 x 65 mm			15-20	40 kg	80 kg	120 kg	240 kg
10 x 65 mm	10 x 65 mm			20	40 kg	80 kg	120 kg	240 kg
10 x 65 mm	10 x 65 mm			12	20 kg	40 kg	100 kg	200 kg
10 x 65 mm	10 x 65 mm			8	20 kg	40 kg	140 kg	280 kg
20 x 40 mm 10 x 65 mm	20 x 40 mm 10 x 65 mm			15	40 kg	80 kg	160 kg	320 kg
20 x 1/1 grid 20 x 20 mm	20 x 2/1 grid 20 x 20 mm			10	80 pcs.	160 pcs.	400 pcs.	800 pcs.
10 x 20 mm	10 x 20 mm		250 480	6	300 port.	600 port.	2400 port.	4800 port.
10 x 65 mm	10 x 65 mm		160-180 320-355	50	250 pcs.	500 pcs.		
10 x 65 mm	10 x 65 mm		160-180 320-355	45	200 pcs.	400 pcs.		
6 x 40 mm 10 x 65 mm	20 x 40 mm 10 x 65 mm		90		40 kg approx.	80 kg approx.		
10 x 95 mm 6 x 150 mm	10 x 95 mm 12 x 150 mm			25-30	80-90 kg	160-180 kg	160-180 kg	320-360 kg
10 x 65 mm	10 x 65 mm			25	20 kg	40 kg	40 kg	80 kg
20 x 20 mm	20 x 20 mm			15	600 pcs.	1200 pcs.	2400 pcs.	4800 pcs.
10 x 65 mm	10 x 65 mm			10	250 port.	500 port.	1250 pcs.	2500 pcs.
10 x 65 mm 10 x 95 mm	10 x 65 mm 10 x 95 mm			soft 7 hard 12				
20 x 40 mm 10 x 65 mm	20 x 40 mm 10 x 65 mm		80 175		50 l approx.	100 l approx.		
20 x 20 mm 10 x 40 mm	20 x 20 mm 10 x 40 mm		230 445	15	20-40 kg	40-80 kg	60-120 kg	120-240 kg
20 x 1/1 grid	20 x 2/1 grid		180-222 355-390	30-40	360 pcs.	720 pcs.		

Food are natural products. Therefore the indicated values for temperature and time may only be seen as approximate standard values.











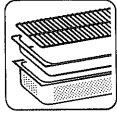

## Original RATIONAL Gastronorm Containers and Grids

---

For the RATIONAL Combi-Steamer CM you can use all GN-containers in different sizes ( $\frac{2}{1}$ \*,  $\frac{1}{1}$ ,  $\frac{1}{2}$ ,  $\frac{1}{3}$ ,  $\frac{2}{3}$ ,  $\frac{2}{8}$ ) for preparing and reheating. Therefore even the loading with small portions enables a flexible and rational production.

### **Containers 20 mm**

for fried potatoes, hamburgers, saddle of hare, potato dumplings, gratinating, thawing.

### **Containers 40 mm**

for meat loaf, meat balls, hamburgers, fried, steamed and poached fish, pastry, vegetable casseroles, duck, goose.

### **Containers 65 mm**

for stuffed cabbage, stuffed peppers, stews, rice, egg royale, vegetable, sauerkraut, different fruit, stewed fruit.

### **Containers 65 mm and 100 mm**

for collecting stock, preparation of sauces, baked ham etc.

### **Perforated containers 65 mm**

for vegetable without stock, side dishes, e. g. dumplings, etc.

### **Perforated containers 95 mm**

for vegetable (blanching e. g. spinach), potatoes, eggs.

### **Perforated containers 150 mm**

for potatoes.

### **Granite enamelled containers**

#### **20 mm, 40 mm, 65 mm**

for baking of different pastry, roasting, gratinating (meat, fish, vegetable), casseroles, stews.

Compared with the CNS-containers the granite enamelled containers provide

#### **decisive advantages :**

- better heat conductivity
- better baking quality
- no sticking
- minimum fat consumption
- no loss in portioning – edges are well formed

Pastry rises better in granite enamelled containers. The bottom of cakes are better baked through and browned in its total surface than in comparable stainless steel containers.

The higher the batters, the more important it is to use granite enamelled containers. The frying result of grilled meat (such as hamburgers) turn out similar – even at the bottom – to the conventional frying in pans.

\* for RATIONAL Combi-Steamer CM 20



## Original RATIONAL Gastronorm Containers and Grids

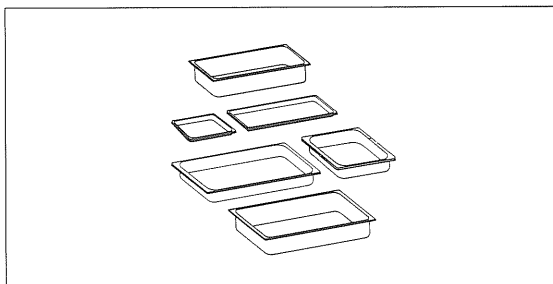

### RATIONAL Containers Stainless Steel

$\frac{1}{3}$ ,  $\frac{1}{2}$ ,  $\frac{1}{4}$  and  $\frac{2}{4}$ \* GN 20 mm deep  
 $\frac{1}{3}$ ,  $\frac{1}{2}$ ,  $\frac{1}{4}$  and  $\frac{2}{4}$ \* GN 40 mm deep  
 $\frac{1}{3}$ ,  $\frac{1}{2}$ ,  $\frac{1}{4}$  and  $\frac{2}{4}$ \* GN 65 mm deep  
 $\frac{1}{3}$ ,  $\frac{2}{4}$ ,  $\frac{1}{4}$  and  $\frac{2}{4}$ \* GN 100 mm deep

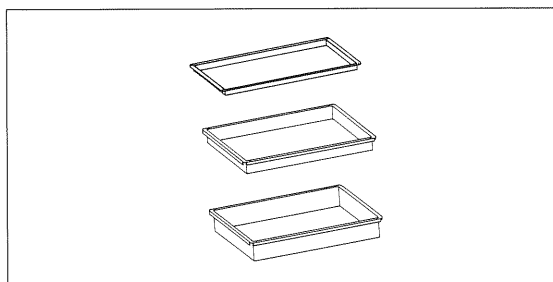

### RATIONAL Containers Granite enamelled

$\frac{1}{4}$  and  $\frac{2}{4}$ \* GN 20 mm deep  
 $\frac{1}{4}$  and  $\frac{2}{4}$ \* GN 40 mm deep  
 $\frac{1}{4}$  and  $\frac{2}{4}$ \* GN 65 mm deep

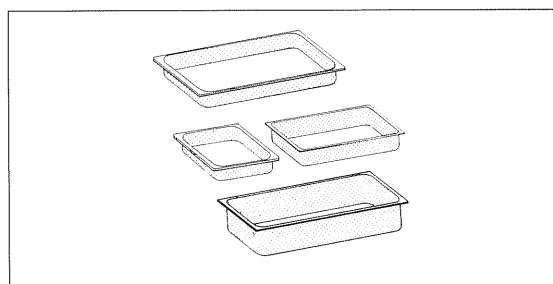

### RATIONAL Perforated Containers Stainless Steel

$\frac{1}{4}$  and  $\frac{2}{4}$ \* GN 65 mm deep  
 $\frac{1}{2}$ ,  $\frac{1}{4}$  and  $\frac{2}{4}$ \* GN 100 mm deep  
 $\frac{1}{2}$  and  $\frac{1}{4}$  GN 150 mm deep

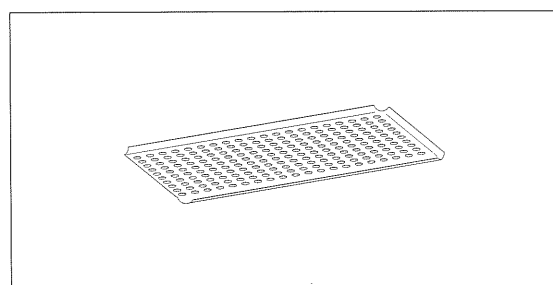

### RATIONAL Baking-tray perforated Aluminium

$\frac{1}{4}$  and  $\frac{2}{4}$  GN 20 mm deep

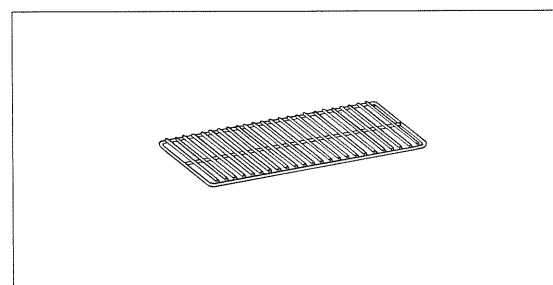

### RATIONAL Grids High gloss nickel plated

$\frac{1}{4}$  and  $\frac{2}{4}$ \* GN

#### Grids

for big roasts (pork, veal, beef, game, lamb),  
grilled meat, toasts, gratinating, chicken, duck,  
goose, cooking in serving dishes, thawing,  
baking in moulds, preserving.

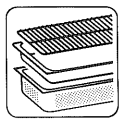

The high operational performance of the RATIONAL Combi-Steamer CM is completed by an efficient coordinated accessory line. Therefore the RATIONAL Combi-Steamer CM can be adjusted perfectly to the individual requirements. The RATIONAL stands and cabinets are made of stainless steel. They guarantee a stable and practical installation of the RATIONAL Combi-Steamer CM.

All RATIONAL floor stands, cabinets and mobile oven racks have U-shaped rail profiles to prevent GN containers from tipping over. Easy loading and unloading is guaranteed by locks.

### RATIONAL Stand UG I

Frame completely made of stainless steel with shelf and adjustable feet.

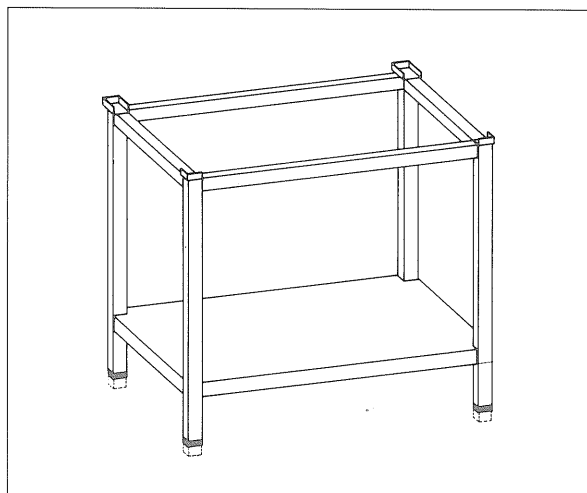

### RATIONAL Floor Stand UG II

Frame completely made of stainless steel with shelf and adjustable feet; in addition 12 pairs of rails for  $\frac{1}{1}$  GN-grids and different GN-containers.

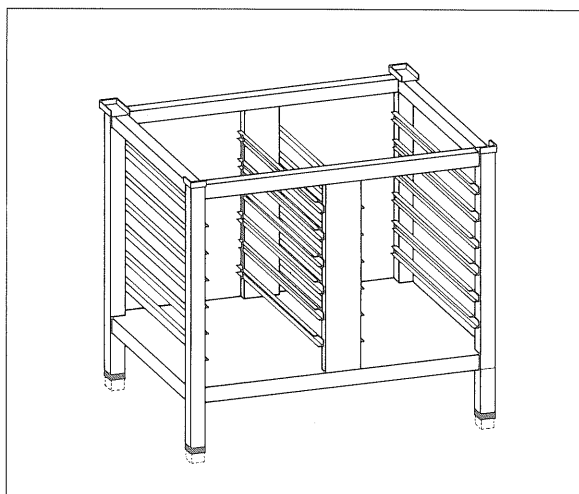

### RATIONAL Cabinet US III

Frame completely made of stainless steel with shelf, adjustable feet, closed at three sides, with 12 pairs of rails for  $\frac{1}{1}$  GN-containers.

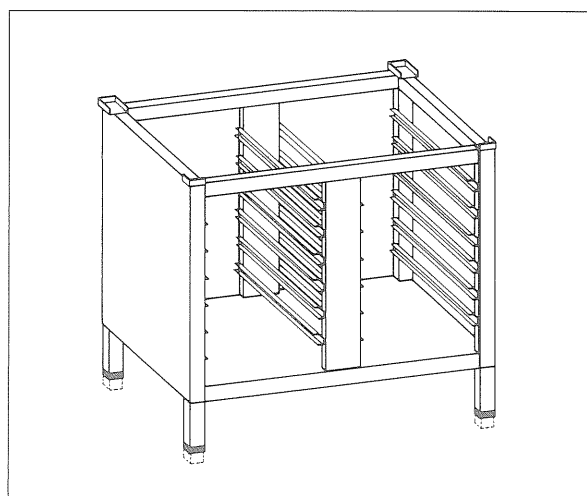

### RATIONAL Closed Cabinet US IV

Frame completely made of stainless steel with shelf, adjustable feet, same version as US III, but equipped at the front with two double-sided swing doors.

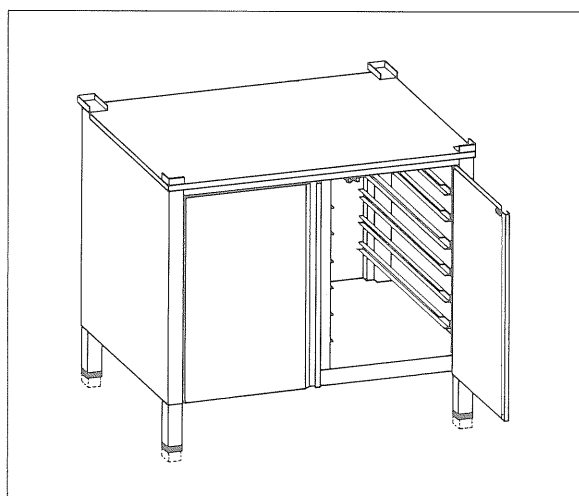

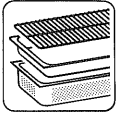

**RATIONAL Mobile Oven Racks**

As additional equipment an important rationalization factor. Completely made of stainless steel with six resp. ten pairs of rails and castors.

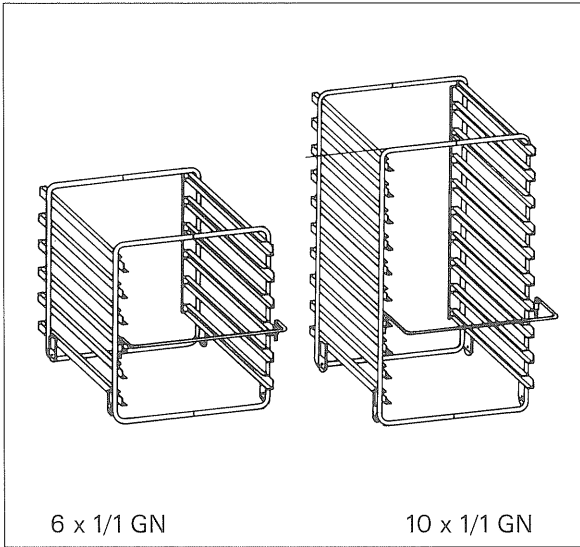

**RATIONAL Special tray frame trolley for serving plates up to 375 mm**

As an additional item of equipment with a significant rationalizing effect. Made entirely of chromium-nickel steel, with six or ten pairs of rails and castors.

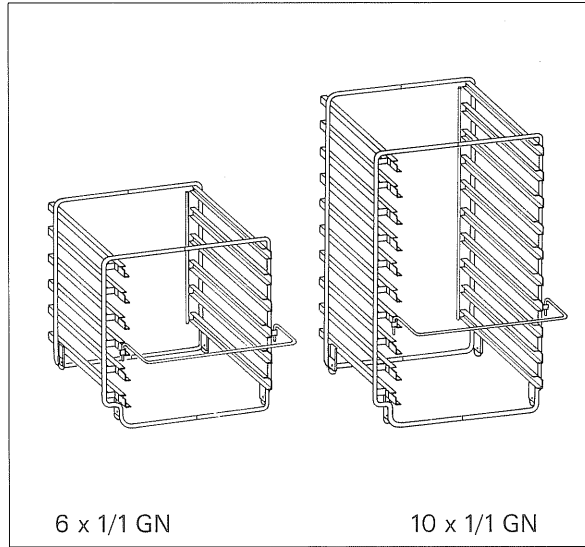

**RATIONAL Transport Trolley**

Facilitates easy transport and quick load changes. Made completely from a chrome-nickel-steel alloy, can be locked to the unit, includes four revolving-type castors (two of them with brakes), drip pan and mobile oven rack arrests. Includes one set of U-rails for a 1/1 GN drip container.

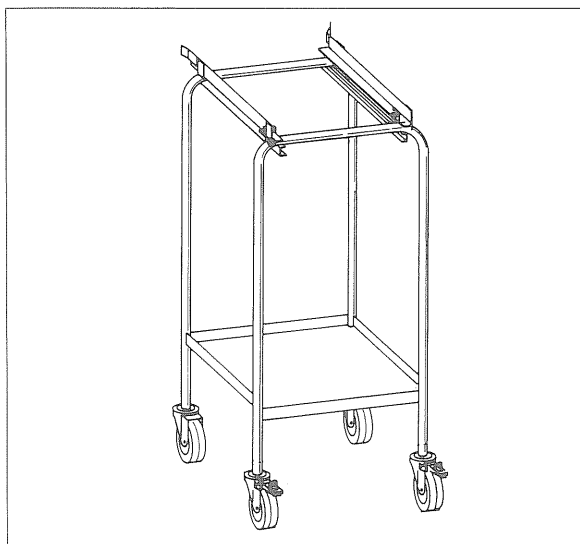

**RATIONAL Fat Filter**

An extra fat filter for changing is advantageous. The fat filter is made of stainless steel.

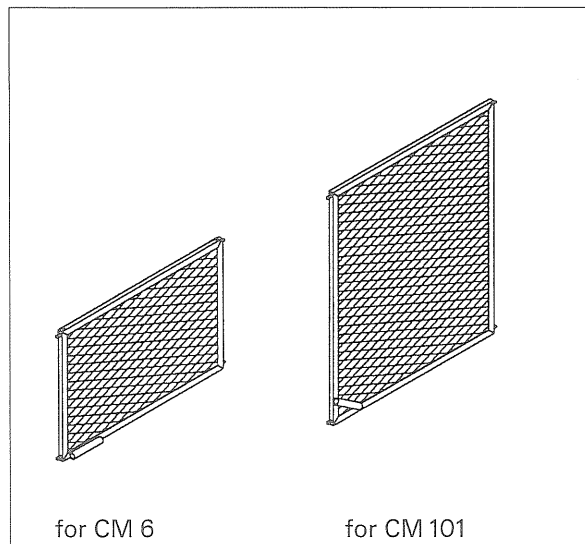

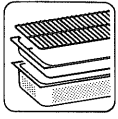

The high operational performance of the RATIONAL Combi-Steamer CM is completed by an efficient coordinated accessory line. Therefore the RATIONAL Combi-Steamer CM can be adjusted perfectly to the individual requirements.

### RATIONAL Mobile Oven Racks

As additional equipment an important rationalization factor.  
Completely made of stainless steel with twenty pairs of rails and castors.

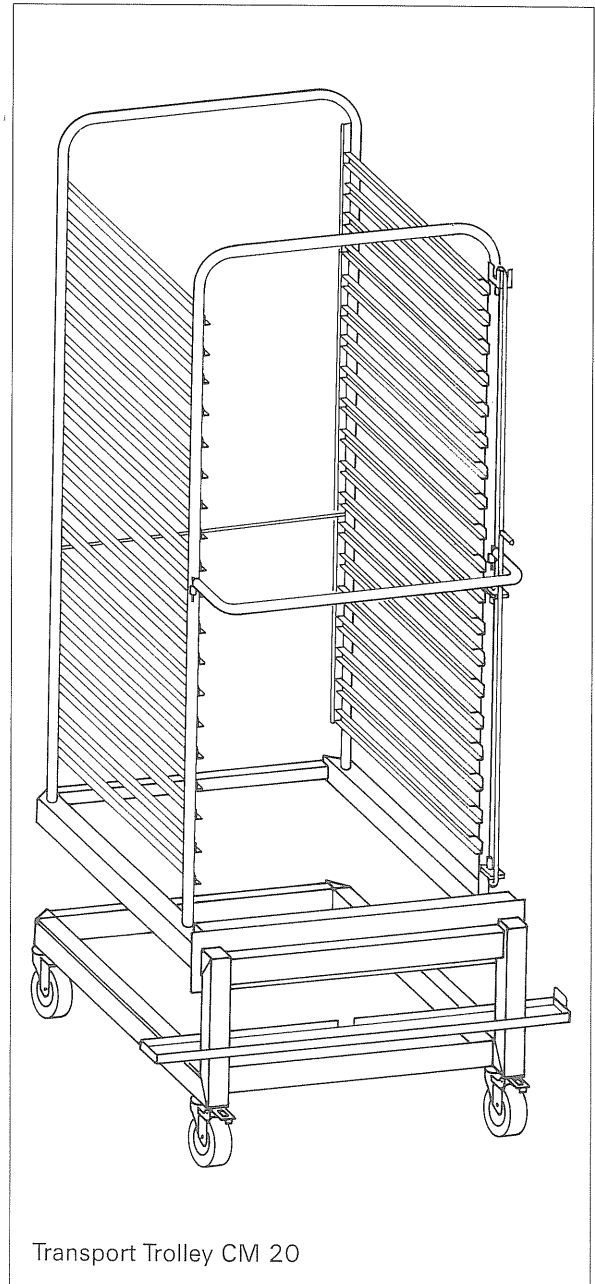
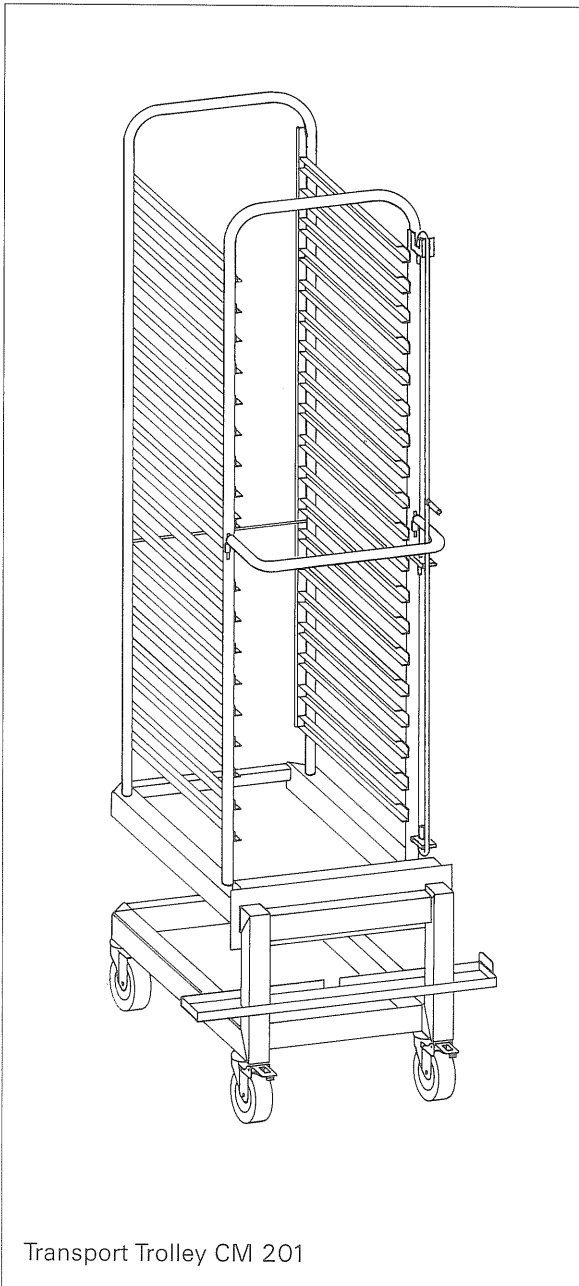





### RATIONAL Fat Filter for CM 201

An extra fat filter for changing is advantageous. The fat filter is made of stainless steel.

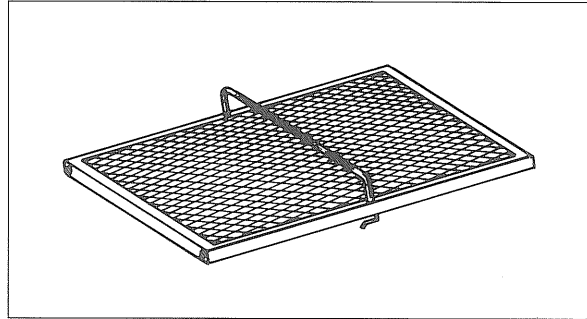

### RATIONAL Fat Filter for CM 20

To cook very **fatty foods**, e. g. chicken or belly of pork, we recommend the use of these special grease filters. They prevent grease burn, thus ensuring a clean atmosphere in the cooking cabinet as it can no longer fill up with smoke.

A set consists of three individual filters (lamellar filters) which are attached to the air baffle, proceeding from the bottom to the top.

Start with grease filter 1 (see drawing) by inserting it into the holder. Now push it up slightly and then let it slip down into the lower holder. Repeat the procedure for the grease filters 2 and 3. Reverse the procedure to remove the grease filters.

**Use the grease filters only when frying and grilling very fatty foods. With other products the cooking time and uniformity can change.**

Two sets of filters are recommended when cooking several batches. In this manner production will not be delayed by the cleaning process.

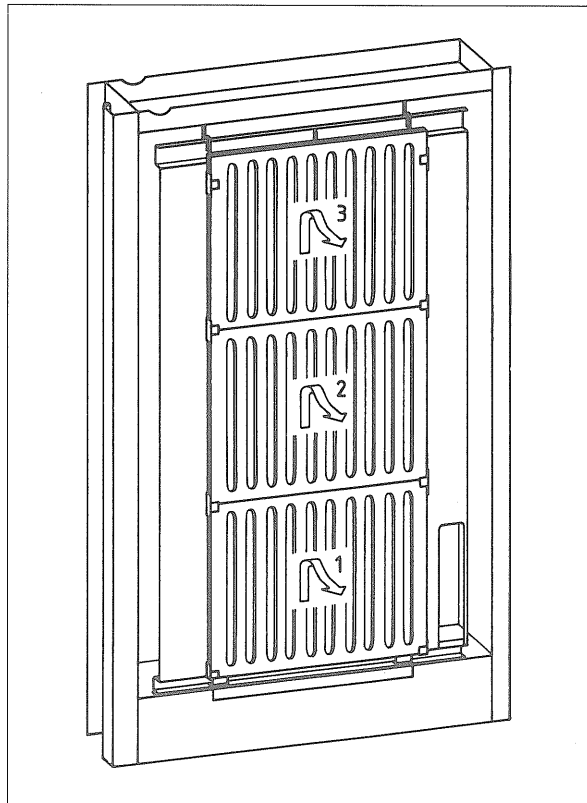



## Cleaning

Daily cleaning of the unit is absolutely essential for hygienic reasons and to prevent operating problems. Please use the RATIONAL Special Cleaner and the RATIONAL Spray Gun.

### Cleaning procedure

- Allow the cooking cabinet to cool down (below 60°C).
- Spray with RATIONAL Special Cleaner and allow it to act (possibly overnight if intensely solid).
- Clean with steam.
- Rinse thoroughly.

### Cleaning procedure in detail:

Spray the inside of the cooking cabinet, the tray frame trolley, and the used containers and grids, thoroughly with RATIONAL Special Cleaner.

### Allow it to act for about 20 minutes.

1. Adjust the mode selecting switch ⑥ to "Steaming".
2. Adjust the timer ⑤ to approx. 15 minutes.
3. Cleaning is finished when the adjusted time has elapsed. The cleaning procedure (points 1 and 2) should be repeated if parts are intensely soiled.

The cooking cabinet must be thoroughly rinsed with clear water after each cleaning process. Rinsing is made very easy with the built-in RATIONAL hose shower. Never use a high-pressure cleaner! Ensure that the grease filter is carefully rinsed. The cooking cabinet is quickly dried by switching on the "Hot Air" mode. The external surfaces are best cleaned with a damp cloth.

### Warning!

Do not clean the outside parts of the unit with a jet of water! The handshower should only be used when the unit is switched off and unplugged. Close the water supply faucet whenever the unit is to be switched off for longer periods of time.

Please ensure that no food particles or remains of cleaner are left on or in accessories and cooking cabinet after cleaning. If there is still residual matter on grids and containers, they should be washed again (e.g. in dishwasher).

Removal of fat filter

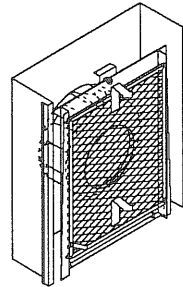

CM 6/CM 101

Removal of air baffle

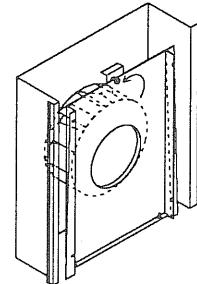

CM 6/CM 101

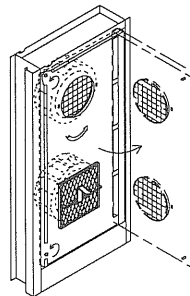

CM 201

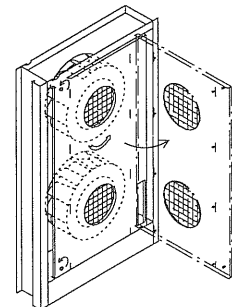

CM 20





Use an original RATIONAL stand or base cabinet (see page 42) for the installation of the unit. If an alternative base is selected ensure that it is level, even and solid. A sloping or uneven base can impair the operation of the unit. Minor unevennesses at the point of installation can be compensated by corresponding height adjustment of the plastic feet. In this way it is also possible to adjust the unit to the height of the transport trolley.

It is essential that space is allowed for cooling air to freely circulate in the area of the air vents (left-hand side of the unit). For this purpose a

spacing of at least 10 cm from the wall or adjoining units must be maintained. There should be no sources of heat in the vicinity of the air vents (left). A spacing of 5 cm is required on the right-hand and rear side.

## Water connection (WZ)

The **cold water connection** is established with a 1/2" pressure hose with 3/4" coupling (see connection diagram).

The operator must provide a stopcock. Do not use a hose-bursting safety device to connect the unit. Valid standard DIN 1988.

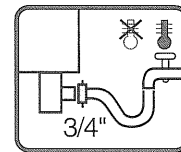

## Drain connection (WA)

Steam temperature resistant pipe DN 50 (ø 50 mm) with constant slope (min. 5% or 3°) for free drainage, max. length 1,5 m. The drain pipe (not a hose pipe) must be straight (no bends) and positioned over the center of the draining funnel. A tapering of the cross section is to be avoided to eliminate danger of reflux. Valid standard DIN 1986, Part 1.

Ensure that the size of the drain is sufficient to handle the pumped discharge rate of the steam generator (0,7 l/second). The waste water temperature averages 65°C.

**Damage and faults resulting from incorrect installation are not covered by our warranty.**

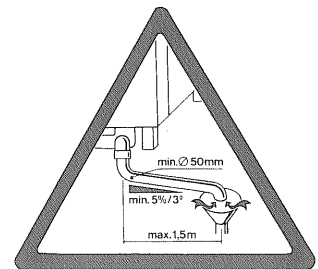

## Electrical connection (EA)

The circuit diagram is located behind the cover of the electrical installation cabinet (Ⓜ). The unit may only be connected to the power supply by an authorized electrician in compliance with the requisite VDE rules and local regulations.

The operator must provide for effective all-pole disconnection to completely isolate the unit from the power supply during repairs and installation work. The unit must be integrated within an equipotential bonding system, and its effectiveness must be verified according to VDE 0190. For this purpose use the screw for equipotential bonding on the front left foot. The earthing conductor should be connected to the corresponding mains terminal (Ⓜ).

## WARNING!

The rotating direction of the fan must be checked after the unit has been connected (see adjoining illustration). The unit will not operate properly if the fan is not rotating in the correct direction, and this can lead to damage.

**The RATIONAL warranty becomes null and void if the Combi-Steamer CM is incorrectly connected.**

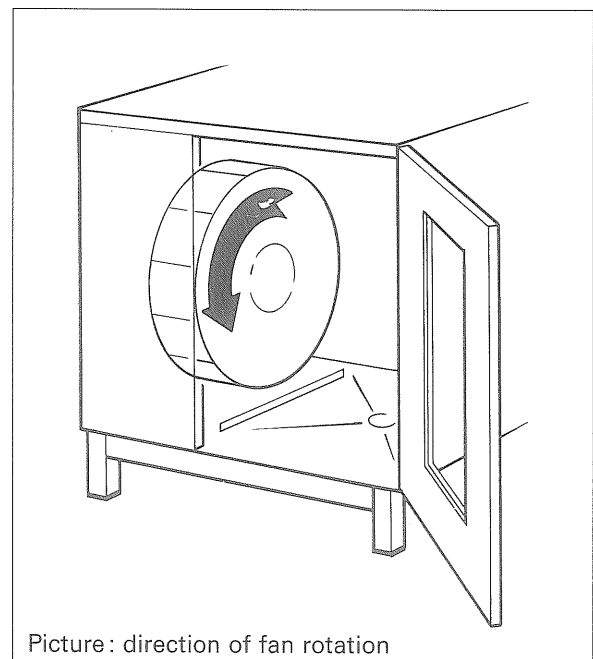

Picture : direction of fan rotation



It is essential that space is allowed for cooling air to freely circulate in the area of the air vents (left-hand side of the unit). For this purpose a spacing of at least 10 cm recommended 35 cm from the wall or adjoining units must be maintained. There should be no sources of heat in the vicinity of the air vents (left). A spacing of 5 cm is required on the right-hand and rear side. Install the RATIONAL Combi-Steamer on a level, even and solid. A sloping or uneven base can impair the operation of the unit. Minor unevennesses at the point of installation can be compensated by corresponding height adjustment of the

feet. Before drilling holes to use the supplied fastening elements, ensure that the following points have been checked out: floor with floor heating system, course of possible pipes, cables and insulations, etc.

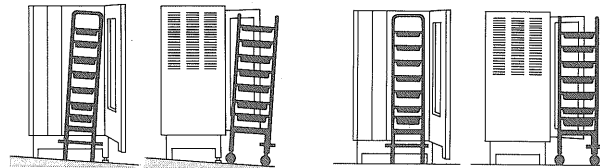

Incorrect

Correct

## Water connection (WZ)

The **cold water connection** is established with a 1/2" pressure hose with 3/4" coupling (see connection diagram).

The operator must provide a stopcock. Do not use a hose-bursting safety device to connect the unit. Valid standard DIN 1988.

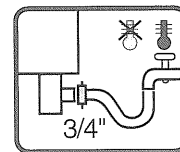

## Drain connection (WA)

DN 50 with constant slope (min. 5% or 3°).

Install the pipe (not a hose) without bends. The pipe should drain into an open funnel (vertically into the center of the funnel) or into a channel. The valid norm is DIN 1986, Section 1. Please make sure the drain system is large enough to manage the drain pump capacity of the steam generator (0,7 l/ second). The average temperature of the drain water is 65°C.

**Damage or malfunctions resulting from faulty installation are not covered by our warranty.**

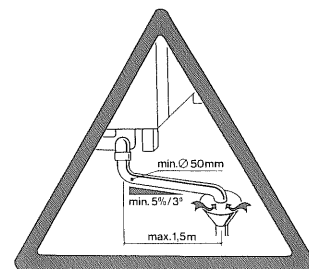

## Electrical connection (EA)

The circuit diagram is located behind the cover of the electrical installation cabinet<sup>®</sup>. The unit may only be connected to the power supply by an authorized electrician in compliance with the requisite VDE rules and local regulations.

The operator must provide for effective all-pole disconnection to completely isolate the unit from the power supply during repairs and installation work. The unit must be integrated within an equipotential bonding system, and its effectiveness must be verified according to VDE 0189. For this purpose use the screw for equipotential bonding on the rear front foot. The earthing conductor should be connected to the corresponding mains terminal  $\oplus$ .

### WARNING!

The rotating direction of the fan must be checked after the unit has been connected (see adjoining illustration). The unit will not operate properly if the fan is not rotating in the correct direction, and this can lead to damage.

**The RATIONAL warranty becomes null and void if the Combi-Steamer CM is incorrectly connected.**

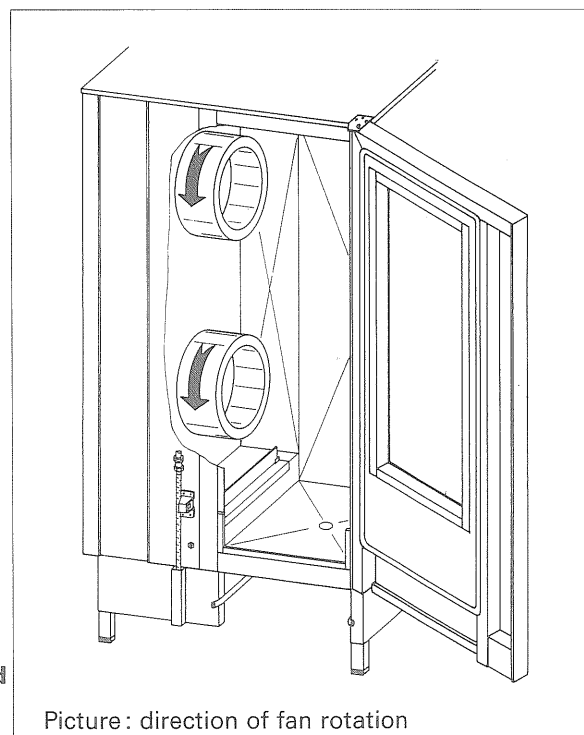

Picture: direction of fan rotation



## Check up before starting the unit Interior lighting

1. Electrical safety measures completed and checked.
2. Fan rotation anti-clockwise! Check the direction of fan rotation from inside the oven (see page 52 and 53).  
**Attention!**  
When the fan turns the wrong direction, the unit will not function properly and damages will occur.
3. The water supply is open and the water connections are tight.  
**Attention!**  
When switching for the first time to the "Steaming", the "Combi-Steamer" or the "Vario-Steamer" mode, the indicator light ② "Lack of Water" may light up red. That means, the steam generator is not yet filled with water. After filling up the indicator light goes out automatically.
4. The drain connection is prepared the right way (see installation and connection).
5. Fat filter and air baffle are inserted properly in foreseen fixtures.
6. Mobile oven rack inserted into backstop.
7. The drip collector ⑤ is inserted.
8. Now the RATIONAL Combi-Steamer CM is ready for operation!



## Interior lighting

### Changing of light bulbs inside the interior cabinet

The diagram shows the exchange of the light bulb. Only the RATIONAL heat resistant special light bulbs are to be used.

When replacing the lamp cover please use a **new gasket** ①.

- A Side wall
- B Lamp socket
- C Light bulb
- D Gasket Handle with care, do not fold.
- E Lamp cover

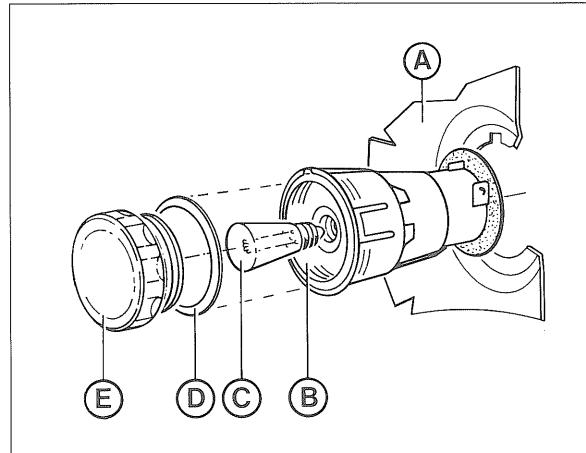

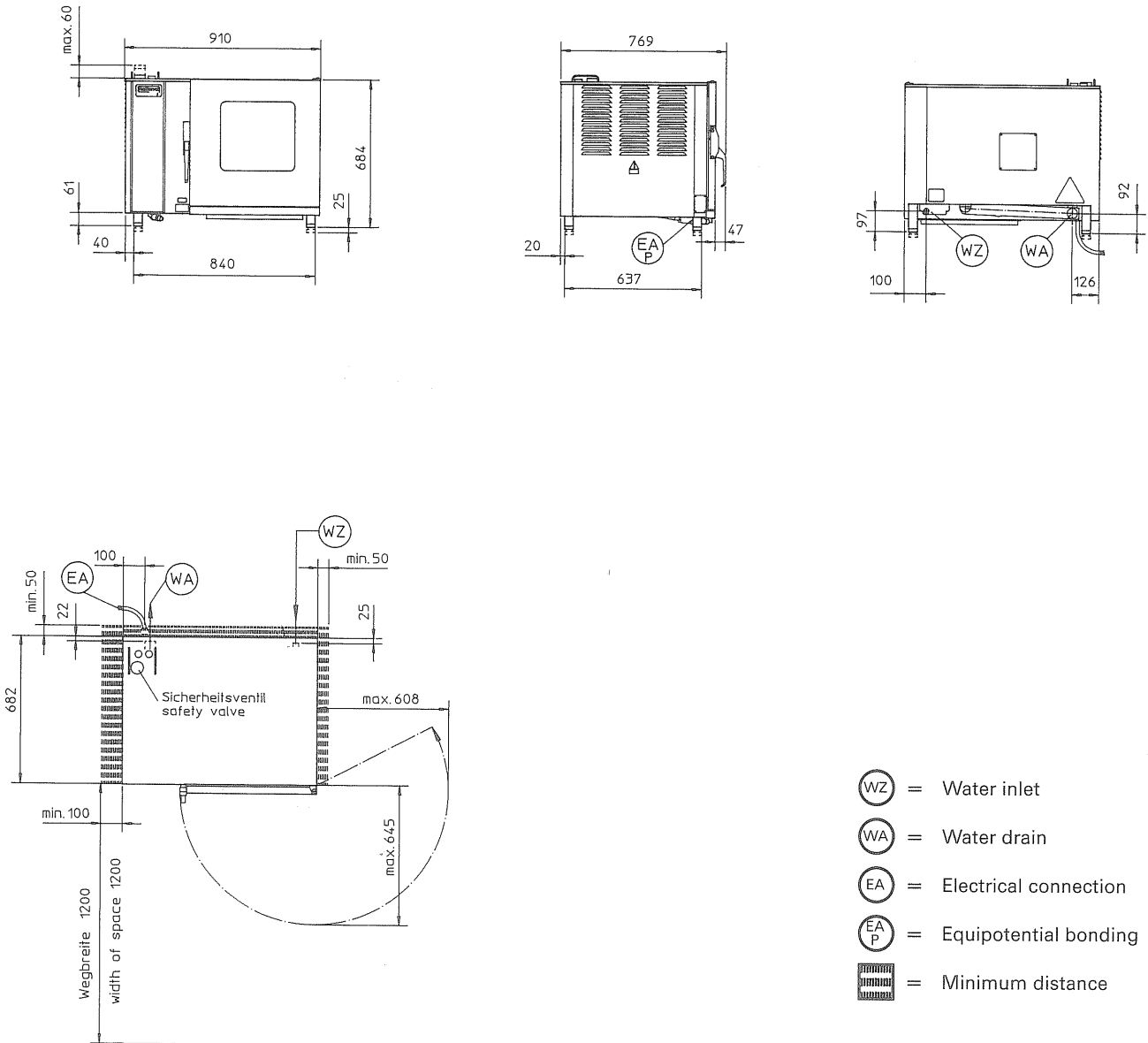

**(WZ) Fresh water connection:**  
R 3/4" thread, 1/2" pressure hose  
Provide water tap.

**Minimum conductivity:** 20µs

**Attention:**

Connect to cold water with drinking-water quality only!

**Water consumption:**

Average value 0.3 l/min (300 kPa)

**Water-pressure:** 150–600 kPa  
recommended: 300 kPa

**(WA) Drain connection:**  
Steam temperature resistant pipe  
DN 50 (ø50 mm) with constant  
slope (min 5% resp. 3°) for free  
drainage, max length 1,5 m.  
German industrial standard  
DIN 1986, part 1.

Ensure a sufficient size of drain:  
pumped discharge rate of steam  
generator 0,7 l/sec.

**(EA) Electrical connection:**  
2 m flexible power cable with  
plug (unit's back side)  
Provide all-phase cut-off  
The appliance may be connected  
only by a properly certified  
electrician at the site.

**Electrical connection  
capacity: 9,4 kW**

- 3 N AC 380V  
5 x 1.5 mm<sup>2</sup>  
Fusing 3 x 16 A
- Special voltages at the circuit  
diagram inside the unit

**Loss capacity** at 220°C working  
temperature ca. 2 920 kJ/h

- (WZ)** = Water inlet
- (WA)** = Water drain
- (EA)** = Electrical connection
- (EAP)** = Equipotential bonding
- = Minimum distance

The hand shower may only be used  
when the unit is switched OFF.

The water supply faucet must  
be closed when the unit is not used  
for a longer period of time.

The increase in temperature of the  
door glass can exceed 60 celvin.

Work station specific sound  
level: 47 dB





Technical variation reserved !

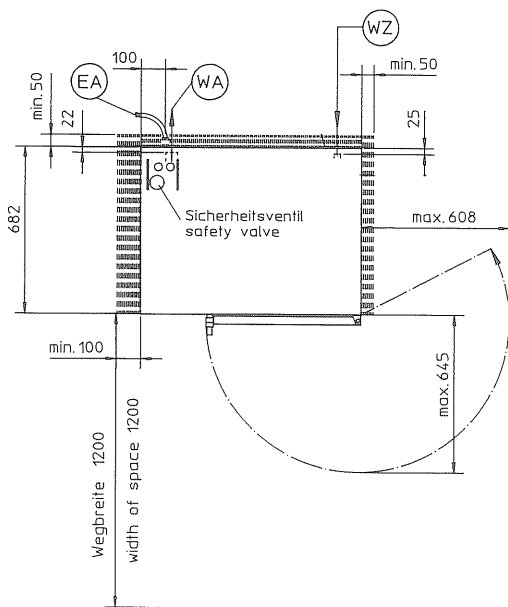
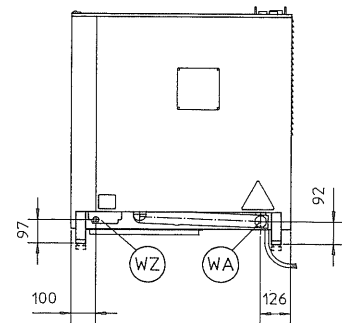
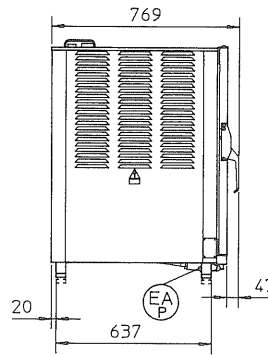
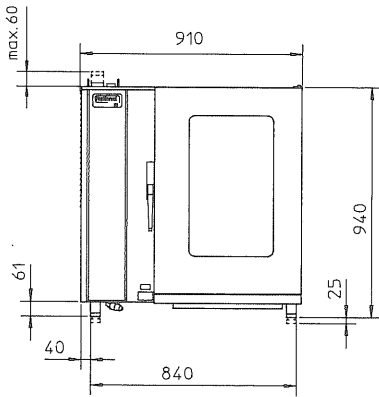

# Connection diagram

# CM 101



-  = Water inlet
-  = Water drain
-  = Electrical connection
-  = Equipotential bonding
-  = Minimum distance

**WZ Fresh water connection:**  
 R 3/4" thread, 1/2" pressure hose  
 Provide water tap.  
**Minimum conductivity:** 20µS  
**Attention:**  
 Connect to cold water with drinking-water quality only!  
**Water consumption:**  
 Average value 0.4 l/min (300 kPa)  
**Water-pressure:** 150–600 kPa recommended: 300 kPa

**WA Drain connection:**  
 Steam temperature resistant pipe  
 DN 50 (ø50 mm) with constant slope (min 5% resp. 3°) for free drainage, max length 1,5 m.  
 German industrial standard DIN 1986, part 1.  
 Ensure a sufficient size of drain: pumped discharge rate of steam generator 0,7 l/sec.

**EA Electrical connection:**  
 2 m flexible power cable with plug (unit's back side)  
 Provide all-phase cut-off  
 The appliance may be connected only by a properly certified electrician at the site.

**Electrical connection capacity: 18,4 kW**  
 a. 3 N AC 380V  
 5 x 4 mm<sup>2</sup>  
 Fusing 3 x 35 A  
 b. Special voltages at the circuit diagram inside the unit

**Loss capacity** at 220°C working temperature ca. 5 010 kJ/h

The hand shower may only be used when the unit is switched OFF.

The water supply faucet must be closed when the unit is not used for a longer period of time.

The increase in temperature of the door glass can exceed 60 celvin.

Work station specific sound level: 57 dB

Technical variation reserved !

# Connection diagram

CM 201

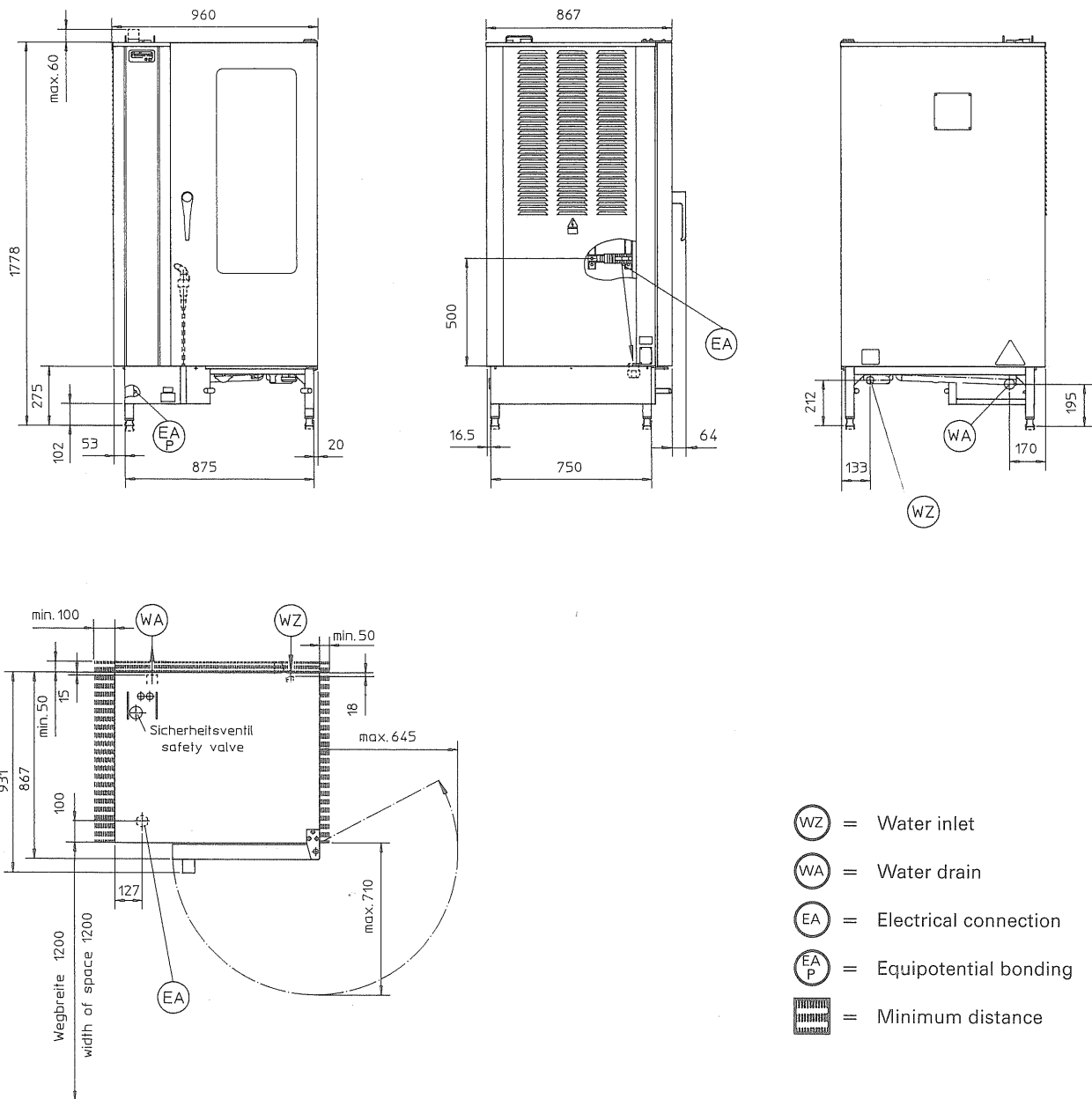

**WZ Fresh water connection:**  
R 3/4" thread, 1/2" pressure hose  
Provide water tap.

**Minimum conductivity:** 20 $\mu$ s

**Attention:**

Connect to cold water with drinking-water quality only!

**Water consumption:**

Average value 0.9 l/min (300 kPa)

**Water-pressure:** 150–600 kPa  
recommended: 300 kPa

**WA Drain connection:**  
Pipe DN 50 ( $\varnothing$  50mm) with a constant slope for free drainage (at least 5% resp. 3°), max length 1.5 m. German industrial standard DIN 1986, part 1. Ensure a sufficient size of drain: pumped discharge rate of steam generator 0,7 l/sec.

**EA Electrical connection:**  
Connecting clamp 35 mm<sup>2</sup> with screw joint PG 36. Provide all-phase cut-off. The appliance may be connected only by a properly certified electrician at the site.

**Electrical connection capacity: 36,6 kW**

- a. 3 N AC 380 V  
5 x 16 mm<sup>2</sup>  
Fusing 3 x 63 A
- b. special voltages at the circuit diagram inside the unit

**Loss capacity** at 220°C working temperature ca. 9 600 kJ/h

The hand shower may only be used when the unit is switched OFF.

The water supply faucet must be closed when the unit is not used for a longer period of time.

The increase in temperature of the door glass can exceed 60 celvin.

Work station specific sound level: 49 dB

Technical variation reserved!

# Connection diagram

# CM 20

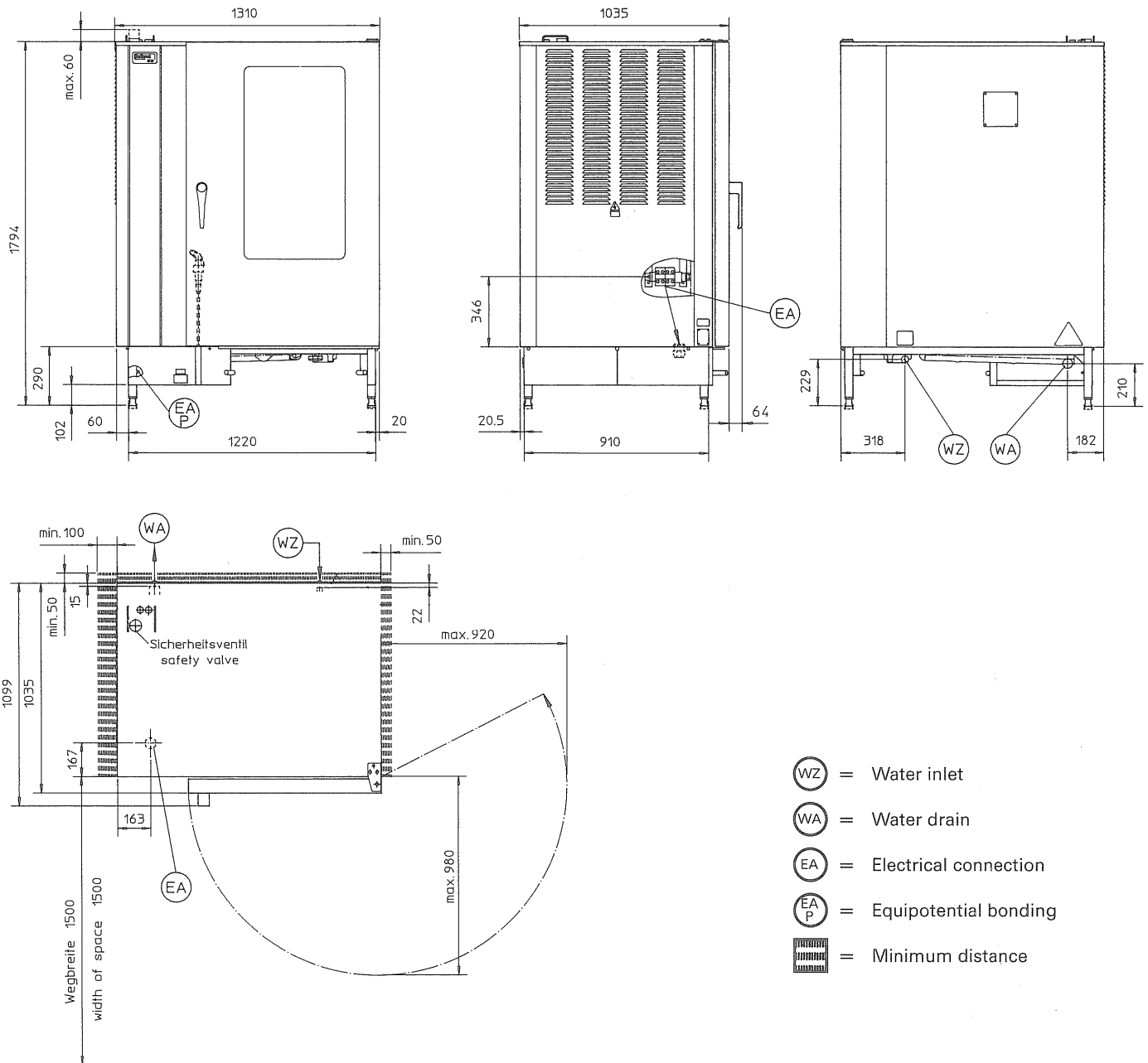

**(WZ) Fresh water connection:**  
R 3/4" thread, 1/2" pressure hose  
Provide water tap.

**Minimum conductivity:** 20µS

**Attention:**

Connect to cold water with drinking-water quality only!

**Water consumption:**

Average value 1.2 l/min (300 kPa)

**Water-pressure:** 150–600 kPa recommended: 300 kPa

**(WA) Drain connection:**  
Pipe DN 50 (ø 50 mm) with a constant slope for free drainage (at least 5% resp. 3°), max length 1.5 m.  
German industrial standard DIN 1986, part 1.

Ensure a sufficient size of drain: pumped discharge rate of steam generator 0,7 l/sec.

**(EA) Electrical connection:**  
Connecting clamp 70 mm<sup>2</sup> with screw joint PG 42.  
Provide all-phase cut-off.  
The appliance may be connected only by a properly certified electrician at the site.

**Electrical connection capacity: 61 kW**

- a. 3 N AC 380 V  
5 x 35 mm<sup>2</sup>  
Fusing 3 x 100 A
- b. special voltages at the circuit diagram inside the unit

**Loss capacity** at 220°C working temperature ca. 13 350 kJ/h

The hand shower may only be used when the unit is switched OFF.

The water supply faucet must be closed when the unit is not used for a longer period of time.

The increase in temperature of the door glass can exceed 60 celvin.

Work station specific sound level: 49 dB

Technical variation reserved!







---

**RATIONAL**  
**Großküchentechnik GmbH**  
Iglinger Straße 62  
D-86899 Landsberg a. Lech  
Tel. (0 81 91) 32 70  
Telefax (0 81 91) 2 17 35

**RATIONAL Singapore**  
**Representative Office**  
58 Tanjong Pagar Road  
Singapore 0208  
Telephone 2272236  
Fax 2271281

**RATIONAL UK LIMITED**  
Unit 4, Titan Court, Laporteway,  
Portenway Business Park,  
Luton, Bedfordshire, LU4 8EF.  
Telephone (01582) 480388  
Fax (01582) 485001