

**OPERATION MANUAL  
FOR**

**MODELS**

**® Blixer 3**

**Serial Numbers BX3/xxxx**

**also covers the BX3 version**

robot coupe U.S.A., Inc.  
P.O. Box 16625, Jackson, MS 39236-6625  
280 South Perkins St., Ridgeland, MS 39157  
email: [info@robotcoupeusa.com](mailto:info@robotcoupeusa.com)  
website: [www.robotcoupeusa.com](http://www.robotcoupeusa.com)  
1-800-824-1646

September 2004

**CAUTION:**

**Always connect the Robot Coupe to a grounded outlet with Ground fault circuit interrupter (GFCI) protection device.**

**Disconnect the machine from the power outlet when not in use and when cleaning or servicing the unit.**

**Machine must be operated and stored in a location not subject to water drips or spray or explosive vapors.**

**The machine must not be modified in any way from its original configuration.**

**Should the machine malfunction or should any part be damaged, it must not be operated until it is repaired by a qualified technician using only genuine Robot Coupe® repair parts.**

**Operating times of 5 minutes or longer can cause processed food to increase to temperatures above 125 F.**

**Failure to follow operating instructions or attempts to operate the machine outside its design limits may create a hazardous condition that could damage the machine and /or injure users.**

**The machine must be operated on a clean sturdy counter or table. Keep the area around and under the machine clear to allow air circulation. Otherwise, the motor can overheat.**

**I. INTRODUCTION**

The **Robot Coupe** commercial food processor performs a host of culinary feats. It is designed for high speed and quality vegetable processing and will *chop, grind, puree and mix* using the cutter bowl attachment.

This operators manual is broken down into sections giving you detailed instructions for assembly and operation of the cutter bowl attachment. Close attention should be paid to all instructions in this manual to ensure a long life utilization of your food processor. **This manual should be kept within easy access to all users for reference, and should be read completely by all first time users of the machine.**

Maintaining the food processor in good working condition is very important. Inspect the machine and all parts regularly to make sure they are in good working condition.

**DO NOT operate a machine that has malfunctioned in any way. Discard any food processed at the time of the malfunction and have the machine inspected and repaired at one of the Robot Coupe Authorized Service Agencies. A list is provided in the back of this manual. Contact one of these service agencies for all of your service, parts and accessories.**

**CAUTION: Your Robot Coupe comes with a sharp cutting “S” blade. Always handle with safety in mind. We suggest that a pair of cutting gloves be worn when handling the “S” blade.**

**Machine Specifications:**

The Model ®**Blixer 3** is equipped with a high speed motor generating 1/2 Hp which plugs into a standard 120 volt/ 60 Hz, 15 amp power outlet. The full load amperage rating is 10 amps. The machine is supplied with a 3 liter stainless steel bowl, with S-blade and clear polycarbonate cover. A bowl and lid wiper assembly is supplied with removable handle.

## II. ASSEMBLY \ DISASSEMBLY INSTRUCTIONS

First, a good working area should be chosen to operate the unit. The motor base should be placed on a counter at a comfortable working height, and have a standard 115 volt power outlet available. Always keep the machine unplugged during assembly and disassembly.

### A. CUTTER BOWL ATTACHMENT ASSEMBLY INSTRUCTIONS

The **®Blixer 3** comes from the factory completely assembled. However, prior to use the machine should be cleaned according to the cleaning instructions detailed in section IV.

There are five basic components of the unit: The assembled motor base which contains the motor and other electrical components, the 3 liter stainless steel bowl, the processing "S" blade, the wiper assembly, and a clear polycarbonate see-through lid.

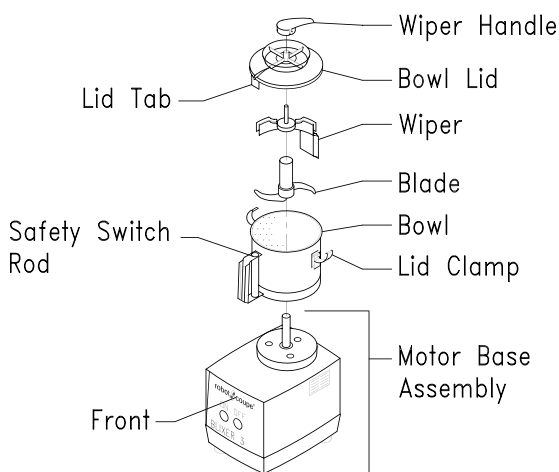

#### Instructions for Assembly:

**Step 1.** Place the bowl on the motor base with the handle just off center and to the left (as you are facing the front) of the center of the motor base and twist counterclockwise. This should lock the bowl into place. When the bowl is in the proper position, it should be level with the top surface of the motor base.

**NOTE:** The machine should not be operated unless the bowl is in the proper position.

**Step 2.** Place the processing blade down on the motor shaft and rotate it until it falls into place. The bottom blade should be located just off the bottom of the bowl when properly in place. **Wear cutting gloves when handling the blade.**

**Step 3.** Push the wiper shaft through the center of the lid from the underside. With the other hand attach the wiper handle. Press the metal button and push the handle on to the wiper shaft. Rotate if necessary to align the square hole in the handle with the square part of the shaft. Press together firmly from both sides. When the button is released it should pop out to its original position.

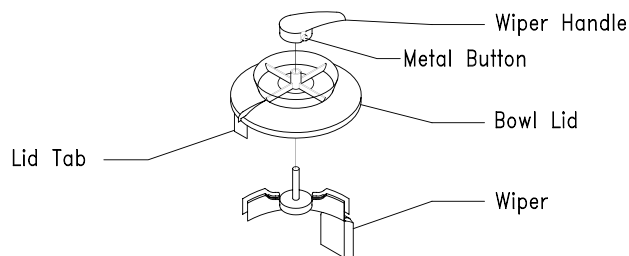

**Step 4.** Notice the raised tab on the top of the lid extending to the edge. At the edge there is another plastic tab extending downward. Place the lid on the bowl so that this tab in the lid assembly will be over the bar on the front side of the bowl. Press the lid down and fasten the hasp type clamps on each side of the bowl over the bowl lid.

**NOTE:** The tab on the lid assembly provides a safety feature for the machine so that if the lid is removed while the motor is running, the magnetic safety switch will stop the motor. **This should only be considered a safety device and not used to turn the machine off. Always use the off switch located on the front of the machine to turn the unit off!** Additionally, always make sure the blades have come to a complete stop before removing the bowl lid. If the safety switch ever fails to operate as described above, the unit should be serviced.

The machine should now be completely assembled and ready to run according to the operation instructions listed in the next Section.

#### Disassembly:

Disassembly of the unit is simply done in reverse order of assembly. Remember to turn the unit off, and make sure the blade has come to a full stop before removing the bowl lid. It is also recommended that the machine be unplugged from the wall socket during assembly and disassembly.

### III. OPERATION

Your Robot Coupe is equipped with a power on and off switch, and magnetic safety switch. The magnetic safety switch is operated through the plastic tab on the lid assembly. When the lid and bowl are locked in position, the magnetic switch is closed allowing the machine to be run by pushing the on and off switches located on the front of the motor base.

#### General Use of the Bowl:

The full capacity of the bowl is 3 liters. As a general rule the machine is operated with a maximum capacity of 1.5 to 2.5 liters, or about 3/4 full. The headspace above the product is required to allow for a vortex or mixing action caused by the blades which is responsible for complete and uniform mixing.

The maximum load limit will vary according to the type of product. Heavy dense products such as meats or pastes, will put a greater strain on the motor. If the motor has trouble starting, reduce the amount of product in the bowl.

Loose or light weight products may be filled in the bowl up to the 3/4 fill level as long as the correct circulation is being obtained. The load limit for loose and light weight products is usually only restricted by the capability of the product to be properly circulated in the container.

The load capacity of liquids is dependent on the viscosity of the liquid. The bowl on the unit is **not** sealed for water tightness. However, the design of the lid and the high center hub in the bowl, allows for a limited volume of these liquids. Generally speaking, thin liquids such as water should not be filled above the top blade. Filling the bowl higher than the center hub with the thin liquid will cause the liquid to leak onto the motor base and possibly leak out the sides of the lid when running.

Thicker liquids approaching the consistency of applesauce and thicker, usually do not present a problem with leaking.

#### Range of Operation:

Your Robot Coupe can perform operations ranging from a coarse chop, to a very fine micron size reduction of solids. It will mix, blend, homogenize, and deaerate powders, solids, and liquids.

#### To Chop:

A uniform chop can be obtained by pulsing the unit on and off very quickly. Load the bowl with solids such as meat portions no larger than 2 inches square and not over 3/4 full. Alternately press the ON and OFF buttons with a quick start/stop action. With this pulsing action the bottom blade tosses the product up allowing the top blade to chop the product. Continue until the desired consistency has been reached.

#### For Complete Size Reduction and Homogenizing:

Load the bowl not over 3/4 full, pieces should not be larger than 2 to 2 1/2 inches square. Turn the machine on and allow to run continuously. Depending on the product, it may be necessary to wipe the walls of the bowl incorporating the accumulated product back into the sample. A larger batch sometimes allows for better circulation. On the other hand, too large a sample may not circulate as well. Most size reduction/homogenizing procedures take about 3 minutes. **Do not leave the machine running unattended.**

Tough or heavy products should be reduced in size by pulsing the unit two or three times. Once the load has been reduced, turn the machine on and run continuously to finish the product. Total processing time should not require more than 3 minutes.

### IV. PREVENTIVE MAINTENANCE GUIDE

Your Robot Coupe has been designed to provide maximum trouble-free performance. Adherence to the assembly and operating instructions will assure good performance and a long life.

#### CARE:

While the Robot Coupe is a ruggedly constructed machine, over-all handling should be accomplished with a sense of use rather than abuse. Reasonable care should be exercised. The unit is made of sturdy plastic material and will yield a long life if not maltreated. While the machine is reasonably portable, care should be taken not to drop it. Equally, it should not be picked up by the bowl, lid, or the cord. The unit should be picked up from the bottom and care should be exercised in relocating it.

#### CLEANING:

Proper cleaning of the unit is one of the MOST IMPORTANT preventive maintenance measures the user can employ. The high acid content of food can cause harm to the electrical parts contained within the housing. Although these elements are isolated from the outside through seals, food juices will tend to seep. If food juices are permitted to collect on the machine over periods of use, erosion of the seals can occur. It is recommended that the machine be cleaned after each operational use, and minimally once per day.

Correct cleaning procedures are required to insure that damage is not inflicted in the cleaning process. The motor base assembly of the unit contains the motor and electrical components.

#### DO NOT IMMERSER THE MOTOR BASE ASSEMBLY IN WATER.

While the bowl, blade and lid, are dishwasher safe, the high temperatures of dish machines will tend to shorten the life of the plastic parts. Hand washing in a pot sink will provide for the longest life of the parts. Cleaning of the blade should be accomplished with care to help prevent cuts. **Wear cutting gloves when handling the blade.** A stiff bristle brush will be effective in knocking the food out of the crevices.

Cleaning of the motor base assembly must be done with care. First, unplug the unit—A sponging with a cloth lightly soaked in a soluble detergent is acceptable, making sure the water is not permitted to penetrate the seals. Always clean the motor shaft.

Periodically lubricate the seals located under the flange at the bottom of the motor shaft. To do this, turn the machine on its side and spray up under the flange with pressurized oil, e.g. WD-40 or mineral oil.

#### **PREVENTIVE MAINTENANCE CHECKS:**

In addition to cleaning the seals, an examination should be made periodically to assure that a seal against food is being maintained. With proper care, and depending on use, the seals should last for a year or more. However, they can and should be replaced when wear or erosion is noted or minimally once per year. It is recommended that the seals be replaced by an authorized repair agency. Good operational performance is obtained when the blades are sharp. Continued use can dull the blade. Replace the blades as needed.

In general, the best preventive measure that can be applied is close adherence to the assembly and operator's instructions along with cleaning and common sense. Make sure the bowl is fitted on flush and rotated in interlock position before operating the machine.

**DO NOT LEAVE THE MACHINE ON WHEN IT IS NOT PROCESSING FOOD.**

**DO NOT PICK UP THE MACHINE BY THE LID, BOWL, CORD, OR BOWL HANDLE, ALWAYS LIFT BY THE BASE.**

**DO NOT PUT YOUR HAND OR FINGERS INSIDE THE BOWL**

**DO NOT ALLOW THE MACHINE TO RUN UNATTENDED.**

**DO NOT RUN THE MACHINE WITHOUT ALL THE PARTS, INCLUDING THE FEET, IN PLACE.**

#### **TROUBLE SHOOTING AIDS:**

The following sections have indicated potential problems and the correct solution which should be implemented by the user. Problems which extend beyond these will require an experienced repairman. A list of the authorized agencies is supplied.

## **V. TROUBLE SHOOTING AIDS**

- A. Unit does not start when assembled correctly
1. Pull plug and try another outlet
  2. Make sure bowl and lid are in the proper position and the plastic lid tab is in line over the magnet bar on the bowl.
  3. Check the built-in reset button (circuit breaker) on the bottom.
- B. Unit stops running while processing
1. Check the built-in reset button (circuit breaker) on the bottom.
  2. **Turn unit off, and unplug machine**
  3. Remove the bowl and blade.
  4. Remove product from bowl
  5. Reassemble unit
- If unit does not operate after following above:
6. Check outlet for current (Breaker or Fuse)
  7. Try unit again
  8. Call local service (factory) agency
- C. Unit starts to spark or smoke
1. **Turn unit off, unplug it**, call local factory authorized service agency.

## **VI. SERVICING OF YOUR ROBOT COUPE**

Your Robot Coupe has a one year limited warranty against defects in parts and workmanship. Should the unit require service, check with your distributor to see where local service is available. If not or if you wish your unit to be serviced at the factory, call for return instructions and upon receipt of same, ship it PREPAID and insured to our factory address.

Robot Coupe USA, Inc. Service Dept.  
Phone: 1-800-824-1646  
601-898-8411

### Model <sup>®</sup>Blixer 3 Wiring Diagram

This diagram also represents Model BX3 <sup>®</sup>Blixer  
Models with Serial Numbers BX3xxxx

*robot coupe<sup>®</sup>*

120 V, 60 Hz, 10.5 AMP  
3450 RPM, 1/2 HP

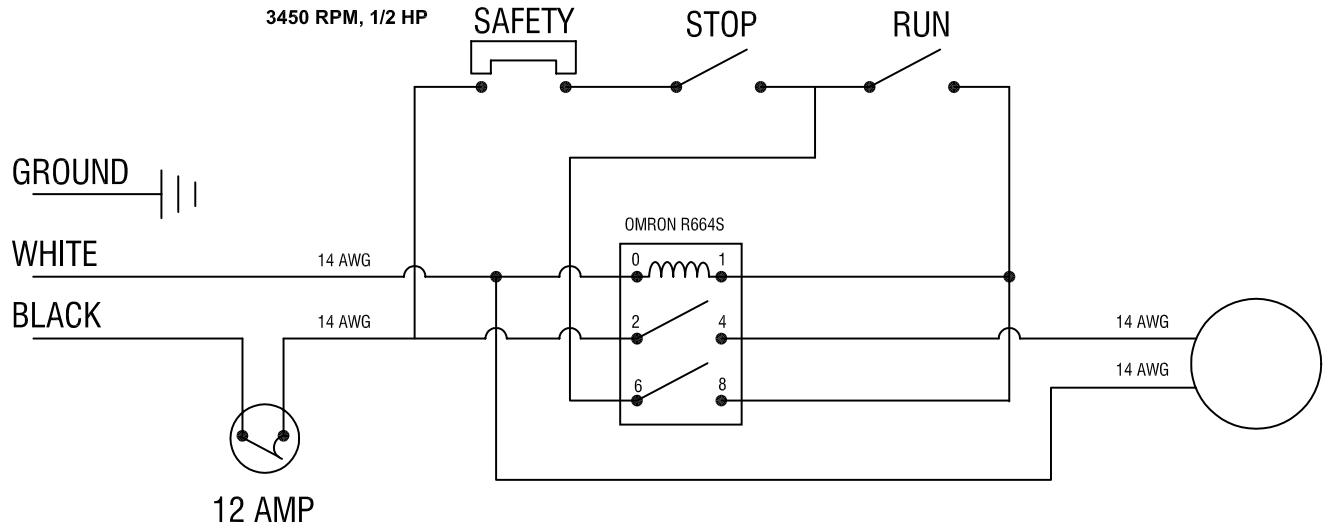

**robot coupe**® U.S.A., Inc.

Phone: 1-800-824-1646  
Fax: 601-898-9134  
email: info@robotcoupeusa.com

# ® Blixer 3

Serial Numbers BX3/xxxx  
1- Speed, 120 Volt, 1 Phase, 60Hz., 1/2 HP.  
3450 RPM, 10.5 Amps

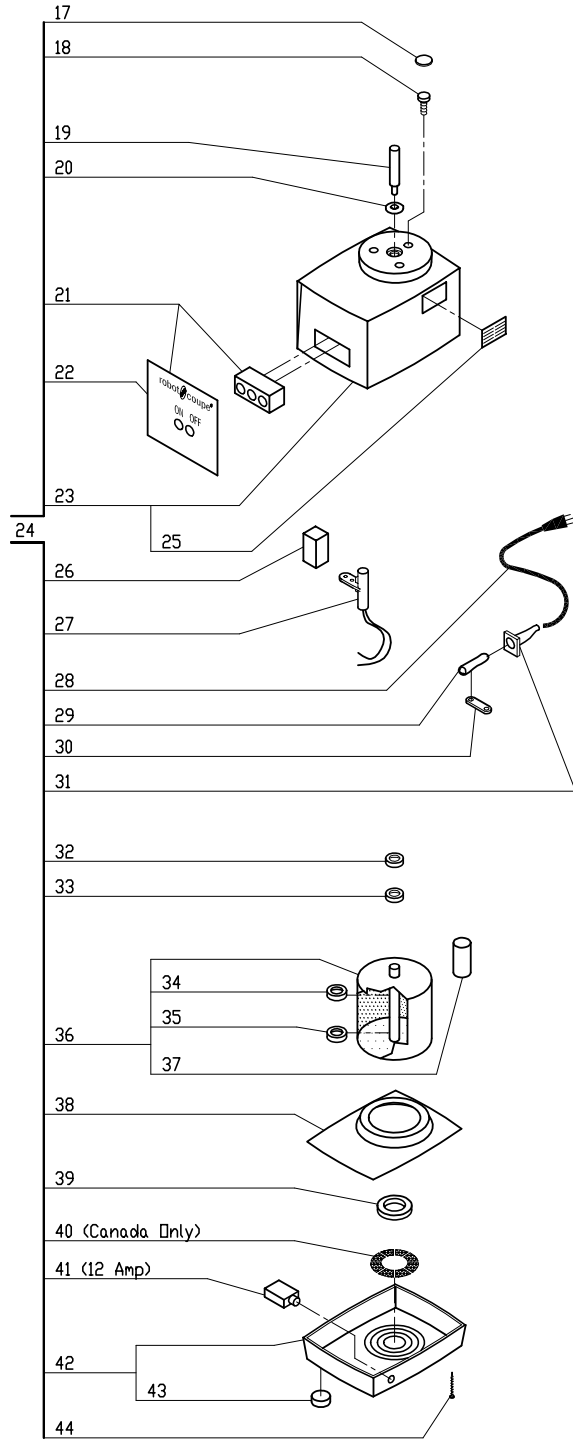
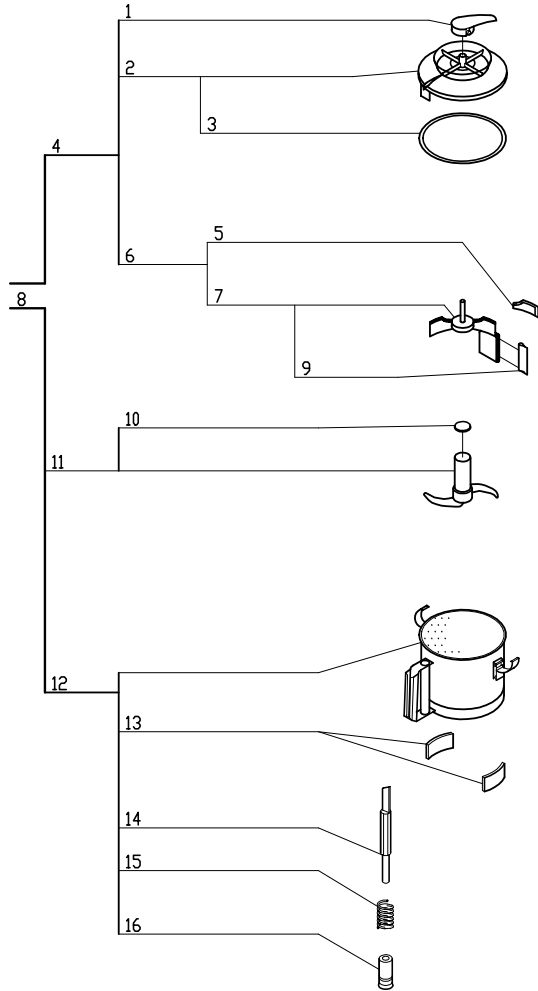
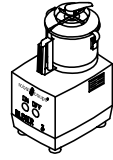

PRICES AND OTHER INFORMATION SUBJECT TO CHANGE WITHOUT NOTICE

| MODEL           |            | Price list for USA only            |
|-----------------|------------|------------------------------------|
| <b>Blixer 3</b> |            | Serial Numbers BX3/xxxx            |
| Indexes         | Part #     | Description                        |
| 1               | BX3031.1   | Handle                             |
| 2               | BX3031.2   | Lid with seal                      |
| 3               | BX3031.3   | Lid Seal (BX3)                     |
| 4               | BX3031     | Lid W/Wiper Blade Assy.            |
| 5               | BX3031.4   | Horizontal Wipe Blade              |
| 6               | BX3031.5   | Holder W/Veri. & Horiz. Wipe Blade |
| 7               | BX3031.7   | Holder W/Vertical Wiper            |
| 8               | BX3032     | *Blixer Bowl Assy                  |
| 9               | BX3031.6   | Vertical Wiper Blade               |
| 10              | BX3029.1   | Blade Cap                          |
| 11              | BX3029     | *Blade (BX3)                       |
| 12              | BX3028     | Bowl Only                          |
| 13              | R3069U     | Lckg Bush Set w/Screws             |
| 14              | BX3028.2   | Pin, Bowl                          |
| 15              | RA424.3    | Spring, Bowl Pin                   |
| 16              | BX3028.3   | Bowl Pin Retaines                  |
| 17              | BX3026     | Screw Cover                        |
| 18              | R3025      | Motor Support Screw                |
| 19              | BX3064     | Shaft                              |
| 20              | R3065U     | Deflector Washer SS                |
| 21              | Number NA  | Description NA                     |
| 22              | Number NA  | Description NA                     |
| 23              | BX3021     | Motor Support BX3                  |
| 24              | Number NA  | Description NA                     |
| 25              | R3022      | Grill                              |
| 26              | R664S      | Relay DPST                         |
| 27              | 39085      | (G) Magnetic Switch Assy, BX3      |
| 28              | R496       | Cord W/Plug (R4X,S,P,Y)            |
| 29              | R3045      | Cord Protector                     |
| 30              | R233       | Strain Relief                      |
| 31              | R3034      | Rubber Cord Sleeve                 |
| 32              | R1716      | Motor Support Seal                 |
| 33              | R1716      | Motor Support Seal                 |
| 34              | R237       | 6203 Bearing R2 Top/Btm            |
| 35              | R237       | 6203 Bearing R2 Top/Btm            |
| 36              | RSI3006U   | Motor 120V 345RPM                  |
| 37              | RSI3006.1U | Start Capacitor(BX3,2Y-1,3Y-1)     |
| 38              | R3005      | Baffle Plate                       |
| 39              | R3004B     | Btm Cushion Bushing,Cent           |
| 40              | R3072      | Screen Kit (Canada Only)           |
| 41              | R286A      | 12 Amp Breaker                     |
| 42              | BX3003     | Base BX3                           |
| 43              | R3001      | Foot, Black                        |
| 44              | R119       | Screw (Base-MS 3.9x19)             |

NA-Not Available

\* Denotes Accessories

NLA-No Longer Available

8/25/04



# **Robot Coupe<sup>®</sup> U.S.A., Inc.**

*P.O. Box 16625, Jackson, MS 39236-6625  
280 South Perkins St., Ridgeland, MS 39157  
email: [info@robotcoupeusa.com](mailto:info@robotcoupeusa.com)  
website: [www.robotcoupeusa.com](http://www.robotcoupeusa.com)  
1-800-824-1646*

## **ROBOT COUPE U.S.A., INC. LIMITED WARRANTY**

**YOUR NEW ROBOT COUPE PRODUCT IS WARRANTED TO THE ORIGINAL PURCHASER  
FOR A PERIOD OF ONE YEAR FROM THE DATE OF PURCHASE**

This LIMITED WARRANTY is against defects in the material and/or workmanship, and includes labor for replacement of defective parts, provided repairs are performed by an authorized service agency (see attached list). The CUSTOMER must inform the Service Agency of the possibility of warranty coverage and provide a copy of the dated sales or delivery receipt BEFORE WARRANTY REPAIRS ARE BEGUN. Replacement parts and accessories are warranted for ninety (90) days from the date of purchase when purchased separately and will be verified by dated sales receipt OR packing slip which list that item. All parts or accessories replaced under warranty must be returned to the Service Agency.

### **THE FOLLOWING ARE NOT COVERED UNDER WARRANTY.**

1. Damage caused by abuse, misuse, dropping, or other similar incidental damage caused by or as result of failure to follow installation, assembly, operating, cleaning, user maintenance or storage instructions, including failure to verify and correct rotation of three phase motors.
2. Labor to sharpen and/or parts to replace knife assemblies or blades which have become dull, chipped, or worn due to normal use.
3. Material or labor to renew or repair scratched, stained, chipped, dented, or discolored surfaces, blades, knives, attachments, or accessories.
4. Transportation charges to or from an authorized service agency for repairs of a machine designated as "CARRY IN SERVICE" (Table Top Models).
5. Labor charges to install or test attachments or accessories (i.e. bowls, cutting plates, blades, attachments) which are replaced for any reason.
6. Charges to change Direction-of-Rotation of Three Phase electric motors (INSTALLER IS RESPONSIBLE). All Robot Coupe products must operate counter-clock-wise.
7. SHIPPING DAMAGE IS NOT COVERED BY WARRANTY. Visible and hidden damages are the responsibility or the freight carrier. The consignee must file a damage claim promptly against the carrier, or upon discovery in the case of hidden damage.

**KEEP ALL ORIGINAL CONTAINERS AND PACKING MATERIALS  
FOR CARRIER INSPECTION**

Robot Coupe U.S.A., Inc., Robot Coupe S.A., or any of their affiliates, distributors, officers, directors, agents, employees or insurers will not be obligated for consequential or other damages, losses, or expenses in connection with or by reason of the use of or the inability to use the machine for any purpose.

**THIS WARRANTY IS GIVEN EXPRESSLY AND IN LIEU OF ALL OTHER WARRANTIES EXPRESSED OR IMPLIED,  
FOR MERCHANTABILITY AND FOR FITNESS TOWARD A PARTICULAR PURPOSE AND CONSTITUTES THE ONLY  
WARRANTY MADE BY ROBOT COUPE, U.S.A., Inc.**