

robot coupe®



P.O. Box 16625, Jackson, MS 39236-6625

280 South Perkins St., Ridgeland, MS 39157

e-mail: robocoup@misnet.com - website: www.robotcoupeusa.com

Phone : 1-800-824-1646

INDEX

■	WARRANTY	■	USES AND CHOICE OF PLATES
■	IMPORTANT WARNING	■	CLEANING
■	INTRODUCTION TO YOUR NEW CL 52 Series "D" VEGETABLE PREPARATION MACHINE	■	MAINTENANCE <ul style="list-style-type: none">• Blades, plates, and grids
■	SWITCHING ON THE MACHINE <ul style="list-style-type: none">• Power supply	■	SAFETY
■	ASSEMBLY	■	TECHNICAL DATA <ul style="list-style-type: none">• Exploded views• Electrical and wiring diagrams

ROBOT COUPE U.S.A., INC. LIMITED WARRANTY

YOUR NEW ROBOT COUPE PRODUCT IS WARRANTED TO THE ORIGINAL PURCHASER FOR A PERIOD OF ONE YEAR FROM THE DATE OF PURCHASE.

This LIMITED WARRANTY is against defects in the material and/or workmanship, and includes labor for replacement of defective parts, provided repairs are performed by an authorized service agency (see attached list).

The Customer must inform the Service Agency of the possibility of warranty coverage and provide a copy of the dated sales or delivery receipt

BEFORE WARRANTY REPAIRS ARE BEGUN. Replacement parts and accessories are warranted for ninety (90) days from the date of purchase when purchased separately and will be verified by dated sales receipt OR packing slip which lists that item.

All parts or accessories replaced under warranty must be returned to the Service Agency.

THE FOLLOWING ARE NOT COVERED BY THE ROBOT COUPE U.S.A. INC LIMITED WARRANTY:

- 1** - Damage caused by abuse, misuse, dropping, or other similar damage caused by or resulting from failure to follow assembly, operating, cleaning, user maintenance or storage instructions.
- 2** - Labor to sharpen and/or replacements for blades that have become blunt, chipped or worn after a normal or excessive period of use.
- 3** - Materials or labor to replace or repair scratched, stained, chipped, pitted, dented or discolored surfaces, blades, knives, attachments or accessories.
- 4** - Any alteration, addition, or repair that has not been carried out by the company or an approved service agency.
- 5** - Transportation of the appliance to or from an approved service agency.
- 6** - Labor charges to install or test new attachments or accessories (i.e., bowls, plates, blades, attachments), which have been replaced for any reason.

7 - The cost of changing direction-of-rotation of three-phase electric motors (Installer is responsible).

8 - SHIPPING DAMAGES. Visible and/or hidden damage is the responsibility of the freight carrier. The consignee must inform the carrier and consignor immediately, or upon discovery in the case of hidden defects.

KEEP ALL ORIGINAL CONTAINERS AND PACKING MATERIALS FOR CARRIER INSPECTION.

Neither ROBOT COUPE U.S.A., INC. nor its affiliated companies or any of its distributors, directors, agents, employees, or insurers will be liable for indirect damage, losses, or expenses linked to the appliance or the inability to use it.

The ROBOT COUPE U.S.A., INC. warranty is given expressly and in lieu of all other warranties, expressed or implied, for merchantability and for fitness toward a particular purpose and constitutes the only warranty made by ROBOT COUPE U.S.A., INC..

IMPORTANT WARNING



WARNING: In order to limit accidents such as electric shocks, personal injury or fire, and in order to limit material damage due to misuse of the appliance, please read these instructions carefully and follow them strictly. Reading the operating instructions will help you get to know your appliance and enable you to use the equipment correctly. The operation manual should be kept within easy access to all users for reference and should be read completely by all first time users of the machine.

UNPACKING

- Carefully remove the equipment from the packaging and take out all the boxes or packets containing attachments or specific items.
- **WARNING**-some of the parts are very sharp e. g. blade, plates ... etc.

INSTALLATION

- We recommend you install your machine on a stable solid base at a comfortable working height.

CONNECTION

- Always check that your power supply corresponds to that indicated on the serial number plate and that it is properly sized.

HANDLING

- Always wear cut-resistant gloves when handling the cutting plates.

ASSEMBLY PROCEDURES

- Follow the various assembly procedures carefully (see page 6) and make sure that all the attachments are correctly positioned.

USE

- Do not open the feed lead until the motor has come to a complete stop.
- Never tamper with or defeat the purpose of the locking and safety systems.
- Never put a hand or nonfood object in the entry or exit chutes.
- Do not overload the machine.

CLEANING

- Always unplug your appliance before cleaning.
- Always clean the appliance and attachments at the end of each use.
- Never place the motor unit in water.
- For parts made of aluminum alloys, use cleaning detergents suitable for aluminum.

- For plastic parts, do not use detergents that are too alkaline (i.e., containing too much caustic soda or ammonia...).
- Robot-Coupe can in no way be held responsible for the user's failure to follow the basic rules of cleaning and hygiene.

MAINTENANCE

- Always unplug the appliance before servicing.
- Check the seals regularly and ensure that the safety devices are in good working order.
- It is particularly important to maintain and check the attachments since certain products contain corrosive agents e.g. citric acid.
- **NOTICE:** Never operate the appliance if the power cord or plug has been damaged. If the machine fails to operate as described in this manual, or if the machine malfunctions in any way, remove the machine from use and have it serviced. Additionally, discard all food processed at the time of the malfunction.
- Contact your local Authorized Service Agency if something appears to be wrong.

INTRODUCTION TO YOUR NEW CL 52 Serie "D" VEGETABLE PREPARATION MACHINE

The CL 52 is a versatile machine designed to meet your professional needs. It can perform a number of tasks, as well as save much in time and labor.

The CL 52 is supplied with a wide range of cutting plates and grids to satisfy even the most demanding chefs when it comes to cutting up fruits and vegetables, i.e. slicing, grating, julienne, dicing and French fries.

Its numerous functions will open the door to a whole new culinary world.

Thanks to its simple design, all components requiring frequent handling for maintenance or cleaning can be easily assembled and disassembled.

All users should read the manual before operating the machine.

SWITCHING ON THE MACHINE

Before connecting, check that your power supply corresponds to that indicated on the machine's serial number plate.

ASSEMBLY

1) With the motor base facing you, place the discharge plate onto the shaft.

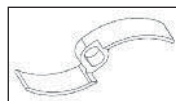
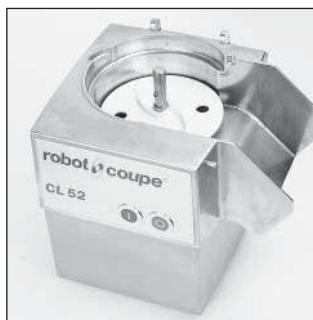

Use the discharge arm for fine grating and slicing only (cabbage, celery, carrots, cheese etc.).

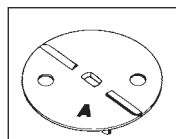

SIDE A facing upwards (ejection rib downwards) for fragile vegetables or citrus fruit (such as tomatoes or mushrooms).

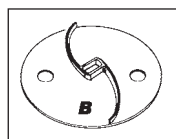

SIDE B facing upwards (ejection rib upwards) for all other types of fruit or vegetables.

2) Position the plate on the motor shaft:

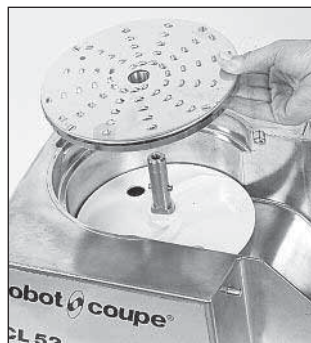

a) If you have opted for a slicing, grating or julienne plate:

Put the plate on the motor shaft. Rotate the plate until it drops into place. The slot in the center stem of the plate should be resting on the motor shaft pin.

b) If you have a dicing combination:

i.e. a grid and a special slicing plate for diced vegetables.

Place the dicing grid over the motor shaft.

As shown in the picture, the grid rests on a ledge in the motor base.

This ledge must be clean and free of product in order for the machine to operate correctly.

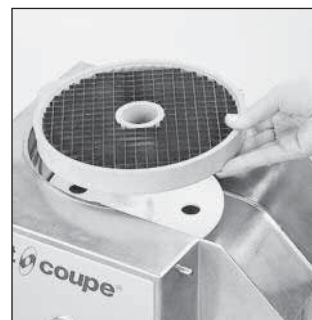

Make sure the plastic tab on the outer rim of the grid is fully seated in the corresponding slot in the motor unit.

Next, fit the corresponding slicing plate (straight edged blade) onto the motor shaft. Rotate the plate until the slot in the blade hub drops onto the pin in the motor shaft.



Continue to rotate the blade a full 360 degrees to make sure the plate doesn't scrub against the plastic grid. **If rubbing occurs-do not proceed. Call your authorized service agency.**

Slicing plates and dicing grids can be mounted in the following combinations:

Plate \ dicing grid	5x5 mm	8x8 mm	10x10 mm	14x14 mm	20x20 mm	25x25 mm
5 mm	28110					
8 mm		28111				
10 mm			28112			
14 mm				28113		
20 mm					28114	
25 mm						28115

c) If you are using a French fry plate combination.

A French fry grid and a special French fry slicing plate make up a combination.

Position the French fry grid over the motor shaft with the raised, bladed grid facing the discharge (exit) chute.

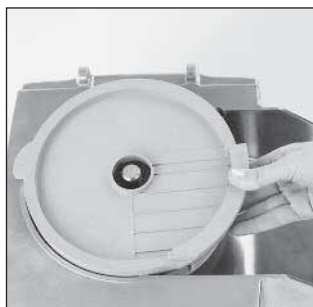

Next put the appropriate slicing plate on the motor shaft.

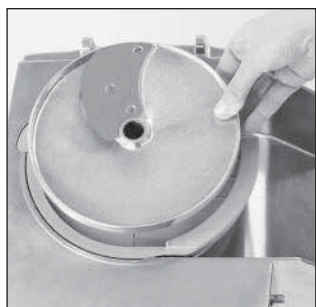

Rotate the plate until the slot in the plate hub falls over the motor shaft pin. Continue to rotate one full turn. **If the cutting plate scrubs the grid-do not proceed-call your authorized service agency.**

The hollowing nut used only to prepare cabbage. This tool can be used to shred or grate a whole cabbage without having to cut it beforehand. **A special tool** has also been designed to **remove** the hollowing nut.



NB : Use the provided wrench to tighten or remove the hollowing nut.

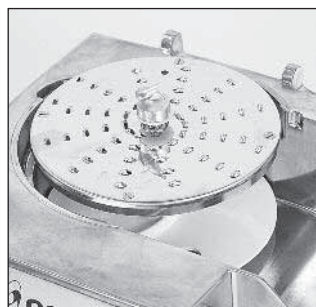

3) Always have the hollowing nut in place when you are not using the divider. Screw the hollowing nut down over the plate, and into the motor shaft.

! WARNING



Use the partition provided and only the feed chute opposite the exit chute when making French fries.



4) Position the lead assembly on the motor base. The latch is now facing you on your right.

5) Slide the hinge pin into the locations provided at the back of the motor base. Then, lock the lead onto the motor base with the latch.



6) If you are not using the hollowing nut, be sure the partition is in place.

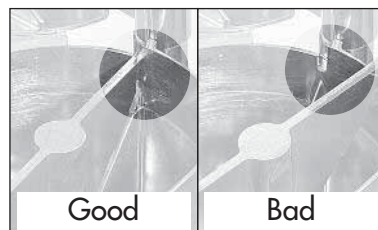

• CHANGING THE PLATES :

Wear cut resistant gloves when handling the plates.

The machine should be switched off (by pressing the red push-button) before changing plates.

1) With the motor unit facing you, use your right hand to release the latch used to lock the attachment onto the motor base.



2) Tilt the attachment back and remove the plate by lifting it from underneath. It may be necessary to turn the plate slightly counterclockwise to loosen it.

For dicing equipment, you are advised to pull out the grid and plate assembly together. Then remove the discharge plate using the two holes.

If the discharge plate is stuck, turn it slightly in the counterclockwise direction.

3) Before assembling the dicing equipment, it is advisable to clean the inside of the motor support / chute thoroughly using a damp cloth or sponge, especially the part onto which the grid is to rest.

Always use a properly cleaned grid.

Never process soft food after hard without cleaning the grid.

4) Then fit the discharge plate, the chosen plate or combination and continue as previously described.

5) Close the lead and fasten the latch before operating.

CONTINUOUS FEED ATTACHMENT

The continuous feed attachment features two feed openings :

A wide feed opening for processing vegetables such as cabbage and lettuce.

A **narrow feed opening** is provided by placing the divider into the wide feed opening. Use this for crosscutting long vegetables such as carrots and cucumbers. Also use the narrow opening when making French Fries.



WARNING



Use the partition provided and only the feed chute opposite the exit chute when making French fries.

GENERAL USE OF THE CONTINUOUS FEED LEAD

Raise the pusher and place the vegetables in the feed opening. Lower the pusher and exert a steady downward pressure on the pusher. Remember that too great a pressure will place unnecessary strain on the motor and can cause the motor to overheat.

Cut cabbages in half and remove the core before processing in order to avoid unnecessary strain and achieve the best cut.

CUTTING PLATE USAGE

SLICING PLATES



C444SA-1/32	carrot / cabbage / cucumber / onion / potato / leek
C445SA-5/64 - C446SA-1/8	lemon / carrot / mushroom / cabbage / potato / cucumber / onion / leek / bell pepper
C477SA-5/32 - C437SA-3/16	beets / carrot / mushroom / cucumber / bell pepper / radish / lettuce / potato / leek / tomato
C436SA-5/16 - C435SA-3/8	potato / carrot / rhubarb / okra / bell peppers
C434SA-9/16	potato / carrot / spinach / pineapple

RIPPLE CUT SLICING PLATES



C445W-5/64	potato / carrot / radishes / cucumbers
C446W-1/8	potato / carrot / kiwi / cucumbers
C464W-3/16	potato / carrot / radishes / oranges / peppers

GRATING PLATES



C494GPA-1/32	cheese / graham crackers / chocolate / almond powder
C451GPA-5/64	carrot / cheese / romano / chocolate / almond powder
C450GPA-1/8	carrot / potatoes / coconut / nut meats / chocolate
C453GPA-3/16	cabbage / cheese / eggs / mozzarella / nut meats
C475GPA-5/32	chocolate / coconut / potatoes / nut meats
C478GPA-9/32	cabbage / cheese / eggs / carrots
C433GPA-3/8	cabbage / onions / provolone / chocolate / radish
C452GPA	powder / hard cheese / almond powder / graham / crackers
C495GPA-1/32	pulping / ginger root / white radish / lotus root / burdock

JULIENNE PLATES



C460JA-5/64x5/64	carrot / potato / zucchini / beets
C483JA-5/64x5/32	carrot / potato / beets / cabbage / zucchini
C484JA-5/64x1/4	carrot / potato / cucumbers / radishes
C486JA-5/64x5/64	zucchini / potatoes / carrots / radishes
C462JA-5/32x5/32	eggplant / potato / tomatoes / zucchini / carrots
C438JA-1/4x1/4	eggplant / potato / carrots
C466JA-5/16x5/16	potatoes / carrots / onions / eggplant

DICING COMBINATIONS



28110-3/16x3/16	carrot / cucumber / potatoes / zucchini
28111-5/16x5/16	potato / carrot / celery / beets
28112-3/8x3/8	potato / carrot / celery / apples
28113-9/16x9/16	potato / carrot / peaches / apples / pineapple
28114-3/4x3/4	potato / cantaloupe / pineapple / melon
28115-1"x1"	potato / turnip / apple (fruit) / melon / watermelon

FRENCH FRY COMBINATIONS (Automatic Feed Head only)



28134-5/16x5/16	potato / carrots / onions / eggplant
28135-3/8x3/8	potato / zucchini / yellow squash / sweet potatoes

CLEANING



WARNING

Always unplug your machine before cleaning (risk of electric shock).

The continuous feed lead, discharge plates, and cutting plates can be cleaned in a dishwasher. However, we suggest that you use a mild (non-corrosive) detergent designed for soft metals such as aluminum.

Dishwashers are best avoided in order to prevent the aluminum from becoming tarnished. Instead we recommend that you clean the machine by hand, using a "soft metal safe" detergent.

NEVER IMMERSE THE MOTOR BASE IN WATER. CLEAN IT WITH A DAMP (NOT DRIPPING), CLOTH OR SPONGE.



IMPORTANT

Check that your detergent is suitable for cleaning plastic parts. Some cleaning agents are too alkaline (e.g. high levels of caustic soda or ammonia) and totally incompatible with certain types of plastic, causing them to deteriorate rapidly.

MAINTENANCE

• BLADES, PLATES AND GRIDS

The blades on the slicing and julienne plates and the grids on the grating plates are all subject to wear and should be changed as required to ensure high quality cutting.

SAFETY



WARNING

The cutting plates are very sharp. Use caution and wear cut resistant gloves when handling the plates.

1) The CL 52 is fitted with a safety system that turns the machine off when the pusher is turned out away from the opening.

The machine will start again once the pusher is swung back into place, over the feed opening. The machine will also stop if the continuous feed lead or lid latch is opened, and the green button must be pressed to restart the unit.

If this system should ever fail, the machine should be removed from use and serviced immediately.

2) The CL 52 is fitted with a temperature fuse that automatically stops the motor if the machine is left on for too long or overloaded. If this happens, allow the machine to cool completely before restarting.

If the machine has become jammed press the off button and UNPLUG the machine from the wall outlet, and restart by first pressing the reset button located on the bottom of the motor base. Then close the lead / attachment, close the latch, and press the on button.



WARNING

Do not open the feed lead until the motor has come to a complete stop.

Never tamper with or defeat the purpose of the locking and safety systems.

Never place anything other than food products into the entry port.

Never put anything into the exit port.

Always use the food pushers to force the food through the entry ports.

Do not overload the machine or apply excess pressure with the food pushers.

CL52 Series D

Series D Machines # 1940111203T-01 and up
 1 Speed, 120 Volt, 1 Phase, 60Hz., 1/2 HP.
 425 RPM, 12 Amps

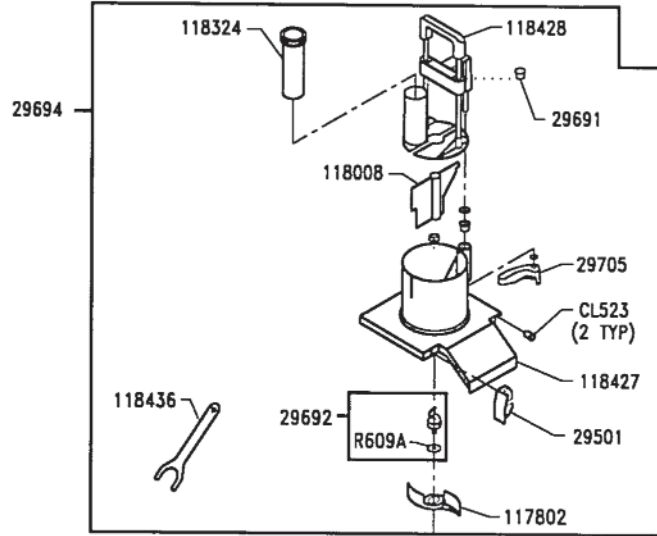
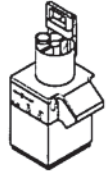

Use only cutting plates listed on the "Series D" Chart.

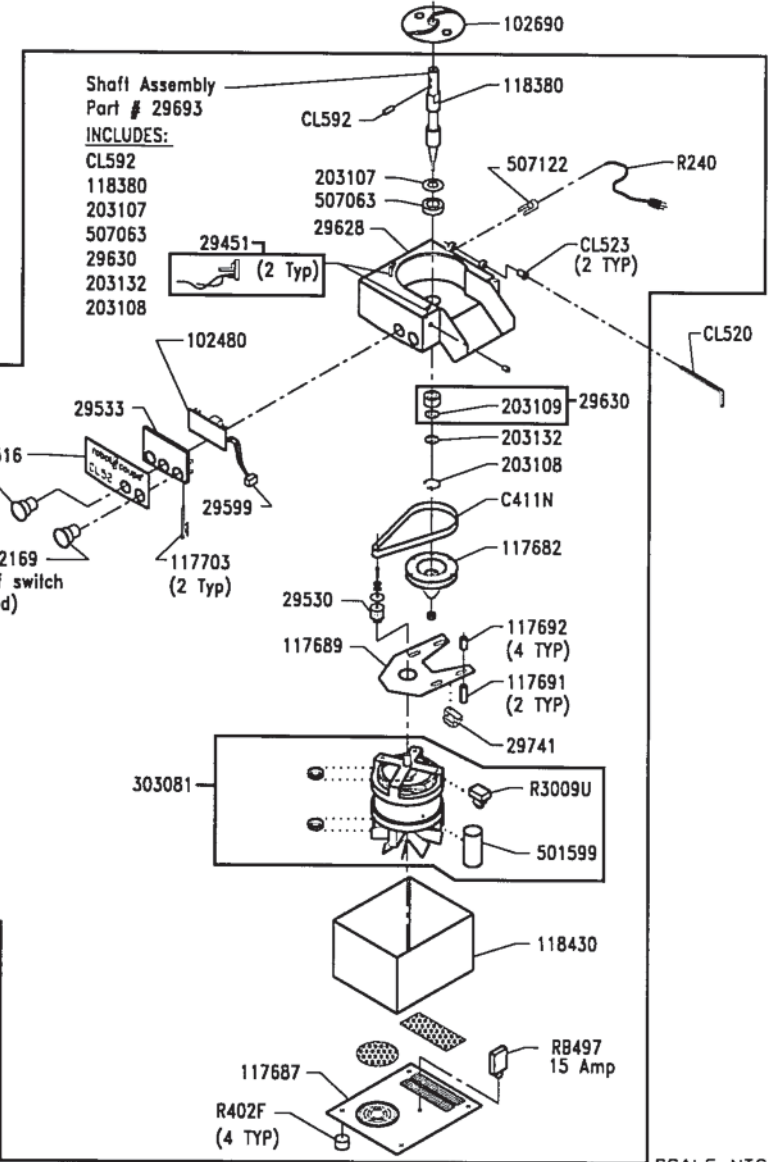

ACCESSORIES

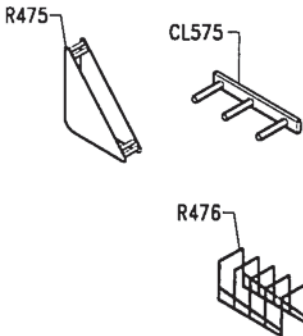

robot coupe U.S.A., Inc.

P.O. Box 16625, Jackson, MS 39236-6625
 280 South Perkins St., Ridgeland, MS 39157
 PH: 1-800-824-1646 FAX: 601-898-9134
 email: robocoup@misnet.com
 website: www.robotcoupeusa.com

© U.S.A., Inc.

SCALE NTS

Part	Description	Part	Description
CL52 Series "D"	Robot Coupe Commercial Food Processor with Whole Head Feed Assembly, and Two Plates (Std. Pack contains C446SA & C450GPA), and Two Plate Racks (R475).	502170	On Switch (Green)
		507063	Bearing/Upper
		507122	Strain Relief
		C404GN	1.5mm Grating Grid Only For C494GPA
		C411N	Belt
		C418GN	7mm Grating Grid Only For C478GPA
		C429JBA	Horizontal Blade (4x4)
		C431JBA	Horizontal Blade (6x6)
		* C433GPA	Extra Coarse (9mm) Grating Plate
* 28110	5x5mm Dicing Kit (Series "D")	* C438JA	6mm Julienne Plate
* 28111	8x8mm Dicing Kit (Series "D")	C439JBA	6mm Julienne Vertical Blade Only
* 28112	10x10mm Dicing Kit (Series "D")	C440JBA	2mm Julienne Horizontal Blade Only
* 28113	14x14mm Dicing Kit (Series "D")	* C444SA	1mm Slicing Plate
* 28114	20x20mm Dicing Kit (Series "D")	* C445SA	2mm Slicing Plate
* 28115	25x25mm Dicing Kit (Series "D")	* C445W	2mm Waved Slicing Plate
* 28117	5mm Dicing Grid Only (Series "D")	C445WD	Waved Blade Only
* 28118	8mm Dicing Grid Only (Series "D")	C446SA	3mm Slicing Plate
* 28119	10mm Dicing Grid Only (Series "D")	C446W	3mm Waved Slicing Plate
* 28120	14mm Dicing Grid Only (Series "D")	C449SBA	1.5mm Blade Only
* 28121	20mm Dicing Grid Only (Series "D")	* C450GPA	Medium (3mm) Grating Plate
* 28122	25mm Dicing Grid Only (Series "D")	* C451GPA	Fine (2mm) Grating Plate
* 28128	5mm Slicing Plate (Series "D")	* C452GPA	Hard Cheese Grating Plate
* 28129	8mm Slicing Plate (Series "D")	* C453GPA	Coarse 5mm Grating Plate
* 28130	10mm Slicing Plate (Series "D")	C454GN	Medium Grating Grid Only for C450GPA
* 28131	14mm Slicing Plate (Series "D")	C455GN	Fine Grating Grid Only for C451GPA
* 28132	20mm Slicing Plate (Series "D")	C456GN	Hard Cheese Grating Grid Only For C452GPA
* 28133	25mm Slicing Plate (Series "D")	C457GN	Coarse Grating Grid Only For C453GPA
* 28134	8x8mm French Fry Set (Series "D")	C458GN	Extra Coarse Grating Grid Only For C433GPA
* 28135	10x10mm French Fry Set (Series "D")	C459BA	Grating Plate Base
29451	Magnetic Switch Assembly	* C460JA	2mm Julienne Plate
29501	Lock For Feed Cover	C461JBA	Vertical Blade Only
29530	Motor Pulley	* C462JA	4x4 Julienne Plate
29533	Mount Spacer for Control Board	C463JBA	4mm Julienne Vertical Blade Only
29564	Blade Only for FF Set (Series "D")	* C464W	5mm Waved Slicing Plate
29599	Control Wire Connector	* C466JA	8x8 Julienne Plate
29628	Motor Support/Chute	C467JBA	8mm Julienne Vertical Blade Only
29630	Bearing Assembly, Lower	* C475GPA	4mm Medium Grating Plate
29691	Pusher Bushing	* C477SA	4mm Slicing Plate
29692	Cabbage Plate Locking Nut	* C478GPA	7mm Grating Plate
29693	Drive Shaft Assembly	C4831JBA	2x4 Julienne Vertical Blade Only
29694	Feed Lead Assembly	C4832JBA	2mm Julienne Horizontal Blade Only
29705	Magnet Safety Arm	* C483JA	2x4 Julienne Plate
29741	Support Plate Brace	C4841JBA	2x6 Julienne Vertical Blade Only
29781	Knife with Screws for Slicing Plate	* C484JA	2x6 Julienne Plate
102480	Control Board	C4861JBA	2x8 Julienne Vertical Blade Only
102690	Discharge Plate	* C486JA	2x8 Julienne Plate
117682	Shaft Pulley, 75 teeth	* C494GPA	1.5mm Grating Plate
117687	Bottom Cover	* C495GPA	1mm Pulping Plate
117689	Motor Support Plate	CL520	Hinge Pin
117691	Base Brace	CL523	Hinge Pin Bushing
117692	Support Plate Brace	* CL575	Stainless Steel Wall Mount Plate Rack
117703	Control Board Retainer Pin	CL590A	5mm Screw
117802	Discharge Vane	CL590B	6mm Screw
118008	Removable Divider	CL590C	8mm Screw
118324	Small Pusher	CL590D	10mm Screw
118380	Shaft Only	CL590E	12mm Screw
118427	Feed Lead	CL592	Shaft Pin
118428	Pusher Assembly	R240	Cord with Plug
118430	Base Cover	R3009U	Relay
118436	Lock Nut Wrench	R402F	Foot
203107	Seal Protector	* R475	Plate Rack
203108	Bushing, Circlip-Shaft	* R476	Plate Rack (3 Plate Capacity)
203109	Thrust Bushing	R609A	Plastic Washer
203132	Washer	RB497	Breaker
303081	Motor Assembly		
406516	Front Data Plate		
501599	Capacitor		
502169	Off Switch (Red)		

* Denotes Accessories

IMPORTANT NOTICE: Use this chart only if a "Series-D" mark is displayed on your machine.

SIZE	SLICING PLATES	REPLACEMENT BLADES (1 PER PLATE)
4 MM.....	C477SA.....	C449SBA
5 MM.....	C437SA.....	C449SBA
8 MM.....	C436SA.....	C449SBA
10 MM.....	C435SA.....	C449SBA
14 MM.....	C434SA.....	C449SBA
19 MM.....	C422SA.....	C449SBA

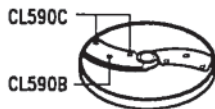
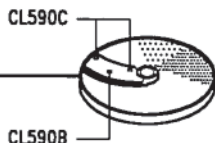

SIZE	SLICING PLATES	REPLACEMENT BLADES (2 PER PLATE)
1 MM.....	C444SA.....	C449SBA
2 MM.....	C445SA.....	C449SBA
3 MM.....	C446SA.....	C449SBA



SIZE	WAVED SLICING PLATES	REPLACEMENT BLADES (2 PER PLATE)
2 MM.....	C445W.....	C445WD
3 MM.....	C446W.....	C445WD

SIZE	WAVED SLICING PLATE	REPLACEMENT BLADES (1 PER PLATE)
5 MM.....	C464W.....	C445WD

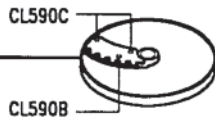

SIZE	GRATING PLATES	REPLACEMENT GRIDS
EX FINE.....	C495GPA.....	C402GN
HARD CHEESE.....	C452GPA.....	C456GN
1.5 MM.....	C494GPA.....	C404GN
2 MM.....	C451GPA.....	C455GN
3 MM.....	C450GPA.....	C454GN
4 MM.....	C475GPA.....	C475.1GN
5 MM.....	C453GPA.....	C457GN
7 MM.....	C478GPA.....	C418GN
9 MM.....	C433GPA.....	C458GN

SIZE	JULIENNE PLATES	REPLACEMENT BLADES VERTICAL	HORIZONTAL
2x2 MM.....	C460JA.....	C461JBA.....	C440JBA*
4x4 MM.....	C462JA.....	C463JBA.....	C440JBA*
6x6 MM.....	C438JA.....	C439JBA.....	C440JBA*
8x8 MM.....	C466JA.....	C467JBA.....	C440JBA*
2x4 MM.....	C483JA.....	C4831JBA.....	C440JBA*
2x6 MM.....	C484JA.....	C4841JBA.....	C440JBA*
2x8 MM.....	C486JA.....	C4861JBA.....	C440JBA*

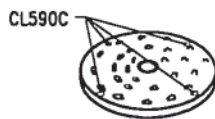

GRATING PLATE BASE
C459BA

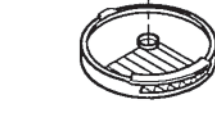
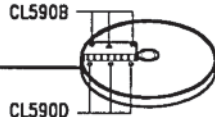

SIZE	FRENCH FRY KIT	PLATE ONLY	BLADE ONLY	GRID ONLY
8x8MM.....	28134.....	29267.....	29564.....	118395
10x10MM.....	28135.....	29276.....	29564.....	118396

USE OLD STYLE (NOTCHED) HORIZONTAL BLADE UNTIL PRESENT SUPPLY RUNS OUT, THEN USE C440JBA.

SIZE	DICING KIT	PLATE ONLY	BLADE ONLY	DICING GRID ONLY
5x5 MM.....	28110.....	28128.....	29780.....	28117
8x8 MM.....	28111.....	28129.....	29780.....	28118
10x10 MM.....	28112.....	28130.....	29780.....	28119
14x14 MM.....	28113.....	28131.....	29780.....	28120
20x20 MM.....	28114.....	28132.....	29780.....	28121
25x25 MM.....	28115.....	28133.....	29780.....	28122

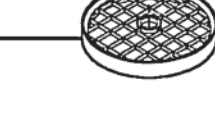
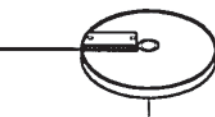

REPLACEMENT SCREWS (TYP)	SCREW#	SIZE
CL590A.....	5mm
CL590B.....	6mm
CL590C.....	8mm
CL590D.....	10mm
CL590E.....	12mm

robot coupe®

MODEL CL52D - CL55D UL

120V-60Hz 1~

C	Connector
CD	Starting capacitor 250µF/120V
DT	Protector 15 A
ILS 1	Lid safety switch
ILS 2	Pusher safety switch
ILS 3	Pusher safety switch Only CL 55D
KD	Starting relay 2CR3 270
R	Résistor 4,7 Ω 8w
⊕	Motor thermal protector

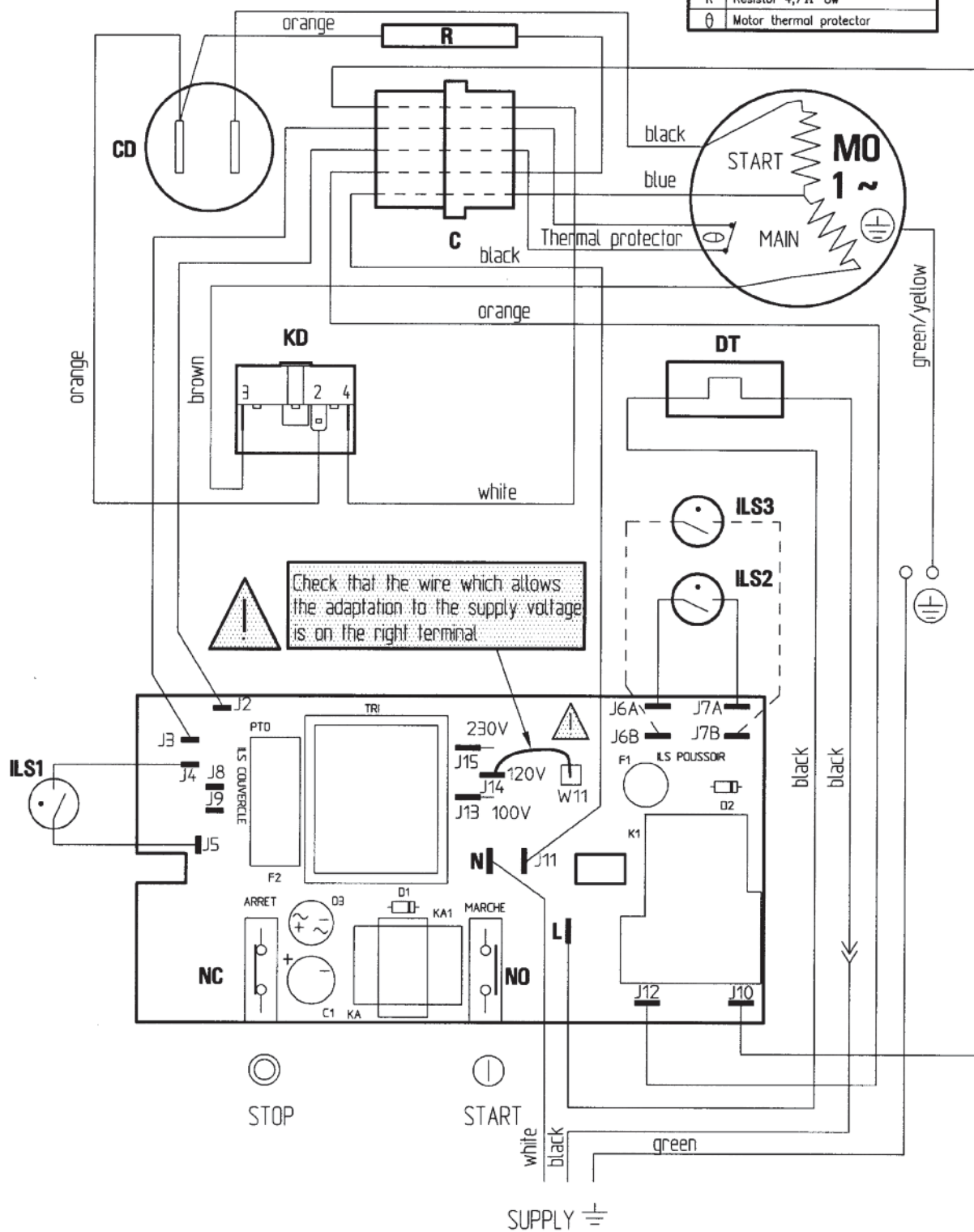

N° 406422 a

MAJ : 10/00

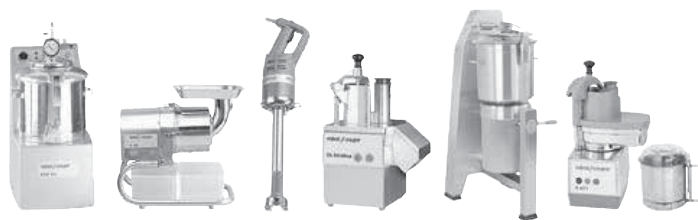

robot coupe[®]

P.O. Box 16625, Jackson, MS 39236-6625

280 South Perkins St., Ridgeland, MS 39157

e-mail: robocoup@misnet.com

website: www.robotcoupeusa.com

Phone : 1-800-824-1646