

robot *coupe*[®]



- **CMP 250 V.V.**
- **CMP 300 V.V.**
- **CMP 350 V.V.**
- **CMP 400 V.V.**
- **CMP 250 Combi**
- **CMP 300 Combi**

Robot-coupe USA. Inc.

P.O. Box 16625, Jackson, MS 39236-6625 - 264 South Perkins St., Ridgeland, MS 39157

e-mail: info@robotcoupeusa.com - website: www.robotcoupeusa.com

Phone : 1-800-824-1646

CONTENTS

■ WARRANTY

■ IMPORTANT WARNING

- Unpacking
- Storage
- Power
- Specifications
- Dimensions
- Safety features
- Warning

■ INTRODUCTION

■ OPERATING THE POWER MIXER

- Operation
- Continuous operation
- Variable speed operation
- Mashed potatoes function

■ WORKING POSITION

- Mixer operation
- Whisk operation

■ ASSEMBLY/DISASSEMBLY

- BLADE

- Attaching the tube to the motor unit
- Removing the tube from the casing
- Attaching the bell to the tube
- Removing the bell from the tube
- Removing the blade

- WHISK

- Attaching the whisk holder to the motor unit
- Removing the whisk casing
- Fitting the whisk into the whisk holder
- Removing the whisk from the whisk holder
- Removing the ejector

■ SPLASH GUARD ASSEMBLY

■ CLEANING

- Motor housing
- Tube and bell
- Blade
- Aluminum
- Plastic
- Whisk holder
- Whisks

■ MAINTENANCE

- Blade
- Tube seal
- Seal ring
- Whisks

■ TROUBLE SHOOTING

■ SERVICE

■ TECHNICAL DATA

- Electrical and wiring diagrams
- Exploded views

ROBOT-COUCPE U.S.A., INC. LIMITED WARRANTY

YOUR NEW ROBOT-COUCPE PRODUCT IS WARRANTED TO THE ORIGINAL PURCHASER FOR A PERIOD OF ONE YEAR FROM THE DATE OF PURCHASE.

This LIMITED WARRANTY is against defects in the material and/or workmanship, and includes labor for replacement of defective parts, provided repairs are performed by an authorized service agency (see attached list). The CUSTOMER must inform the Service Agency of the possibility of warranty coverage and provide a copy of the dated sales or delivery receipt BEFORE WARRANTY REPAIRS ARE BEGUN. Replacement parts and accessories are warranted for ninety (90) days from the date of purchase when purchased separately and will be verified by dated sales receipt OR packing slip which lists that item. All parts or accessories replaced under warranty must be returned to the Service Agency.

THE FOLLOWING ARE "NOT" COVERED UNDER WARRANTY:

1 - Damage caused by abuse, misuse, dropping, or other similar incidental damage caused

by or as a result of failure to follow assembly, operating, cleaning, user maintenance, or storage instructions.

2 - Labor to sharpen and/or parts to replace knife assemblies or blades which have become dull, chipped, or worn due to normal use.

3 - Material or labor to renew or repair scratched, stained, chipped, dented or discolored surfaces, blades, knives, attachments, or accessories.

4 - Transportation charges to or from an authorized service agency for repairs of a machine designated as "CARRY IN SERVICE" (table top models).

5 - Labor charges to install or test attachments or accessories (i.e., bowls, cutting plates, blades, attachments) which are replaced for any reason.

6 - Charges to change Direction-of-Rotation of Three Phase electric motors (INSTALLER IS RESPONSIBLE).

7 - SHIPPING DAMAGE IS NOT COVERED BY WARRANTY. Visible and hidden damages are the responsibility of the freight carrier. The consignee must file a damage claim promptly against the carrier, or upon discovery in the case of hidden damage.

KEEP ALL ORIGINAL CONTAINERS AND PACKING MATERIALS FOR CARRIER INSPECTION.

Robot-Coupe U.S.A., Inc., Robot-Coupe S.A. or any of their affiliates, distributors, officers, directors, agents, employees, or insurers will not be obligated for consequential or other damages, losses, or expenses in connection with or by reason of the use of or inability to use the machine for any purpose.

THIS WARRANTY IS GIVEN EXPRESSLY AND IN LIEU OF ALL OTHER WARRANTIES, EXPRESSED OR IMPLIED, FOR MERCHANTABILITY AND FOR FITNESS TOWARD A PARTICULAR PURPOSE AND CONSTITUTES THE ONLY WARRANTY MADE BY ROBOT-COUCPE, U.S.A., Inc.

IMPORTANT WARNING



WARNING : In order to limit accidents such as electric shocks, personal injury or fire, and in order to limit material damage due to misuse of the appliance, please read these instructions carefully and follow them strictly. Reading the operating instructions will help you get to know your appliance and enable you to use the equipment correctly. The operation manual should be kept within easy access to all users for reference and should be read completely by all first time users of the machine.

UNPACKING

- Carefully remove the equipment from the packaging and take out all the boxes or packets containing attachments or specific items.
- **Warning- Some parts are very sharp e.g. blade. Wear cutting gloves when handling the blade.**

STORAGE

- You are advised to install the wall bracket provided with the machine and to store your Power Mixer on it. Hang the mixer with the motor unit UP.

POWER SUPPLY

- Connect the mixer to 110-120 Volt 60 Hz Power supply.
- Connect the mixer only to Ground Fault Interrupt (GFI) Safety type outlet.
- Do not connect the mixer with extension type power cord.
- GFI type outlets protect the machine from expensive damage and protect the operator from serious injury or death.

SPECIFICATIONS

- CMP 250 V.V. 120V/60Hz / 3 Amp.
- CMP 300 V.V. 120V/60Hz / 3.2 Amp.
- CMP 350 V.V. 120V/60Hz / 3.5 Amp.
- CMP 400 V.V. 120V/60Hz / 4 Amp.
- CMP 250 Combi 120V/60Hz / 3 Amp.
- CMP 300 Combi 120V/60Hz / 3.2 Amp.

DIMENSIONS (in inches)

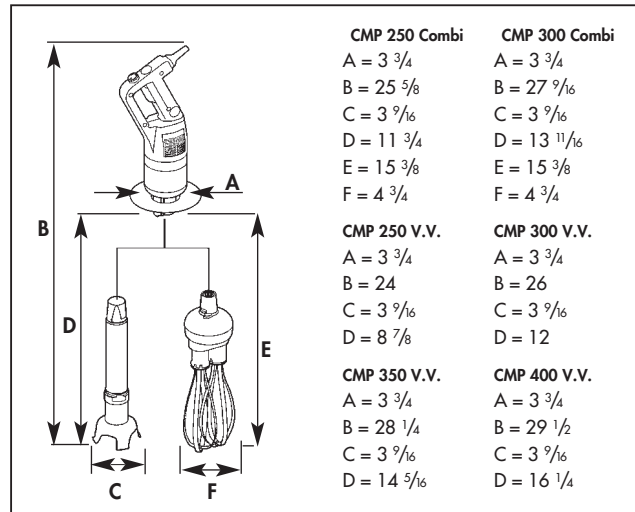

Blade Attachment Capacities

- Thanks to a very powerful motor, the CMP 250 can process up to 16 quarts, CMP 300 can process up to 32 quarts, the CMP 350 up to 50 quarts, the CMP 400 up to 65 quarts. The quality of the finished product is outstanding.

Whisk Attachment Capacities

- Using the whisk attachment CMP 250 Combi and CMP 300 Combi process from 2 to 30 egg whites and puree 2 to 70 pounds.
- Each power mixer is supplied with a wall support for easy storage.

SAFETY FEATURES

• Safety on Control Switches

This safety mechanism prevents any unintentional starting of the power mixer. Two buttons must be pressed to start the power mixer. See section on operating the power mixer.

• Safeties on motor : Thermal and overload protection.

If there is an obstruction in the container (a spoon or utensil) or the machine is overused and becomes hot the power mixer will stop. If the power mixer stops because of a thermal overload (power mixer is too hot), wait for a period of up to 30 minutes for the power mixer to cool down before restarting.

• No volt release safety (Supply failure).

If there is a power failure or the machine is unplugged, the power mixer will not restart by itself. See section on operating the power mixer.

WARNING

- **Be careful when handling the blades. They are very sharp! Wear cutting gloves when handling the blades.**

INTRODUCTION TO YOUR NEW ROBOT-COUPÉ POWER MIXER

Robot-Coupe has developed a complete line of power mixers. The features of each are described in the table below.

Models	Variable speed	Mixer attachment	Whisk attachment
CMP 250 V.V.	•	•	
CMP 300 V.V.	•	•	
CMP 350 V.V.	•	•	
CMP 400 V.V.	•	•	
CMP 250 Combi	•	•	•
CMP 300 Combi	•	•	•

The Robot-Coupe Power Mixers perform a host of culinary feats. **The mixer attachment** will allow you to make soups, vegetable purees and pulps while **the whisk attachment** is ideal for making pancake batter, mayonnaise, beaten egg whites, chocolate mousse, butter sauces, whipped cream or smooth fromage frais.

The **variable speed function** will enable you to adjust the speed to suit each preparation and to start the processing at a lower speed in order to reduce splashing.

The power mixer is easily assembled and disassembled for maintenance and cleaning.

OPERATING THE POWER MIXER

• OPERATION

The power mixer is equipped with electrical current and temperature overload protection. If the power

mixer stops unexpectedly you may try to restart it by following steps 3-5 below. If the power mixer does not restart, allow it to cool for a period of up to 30 minutes and the temperature overload will automatically reset. You should then be able to restart following steps 3-5 below.

1. Check that the control button (CB) is in the released position.
2. Connect the cord to the power supply
3. Put the tube into the product **with the bell completely immersed and the splash guard in place.**
4. Press and hold down the safety button (SB).
5. Press the control button (CB) and the power mixer will start.
6. Release the safety button (SB).
7. To stop the power mixer, release the control button (CB).

• CONTINUOUS OPERATION

8. Follow steps 1-6 above, then: While the control button (CB) is pressed, press the locking button (LB).
9. Release the control button (CB).
10. Release the locking button (LB), and the power mixer will run continuously.
11. To stop the power mixer, press and release the control button (CB).

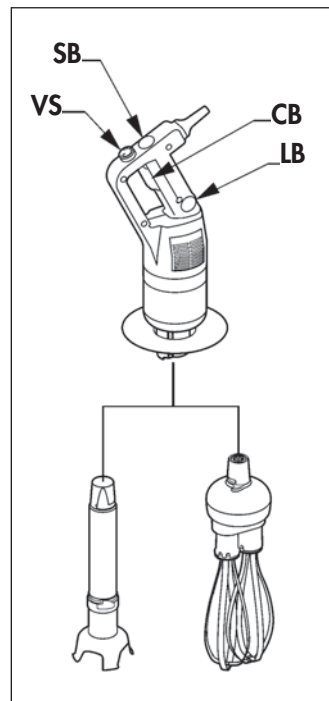

• VARIABLE-SPEED OPERATION

Follow steps 1 to 6 above, then change the speed of the motor by turning the button (VS) toward the maximum or minimum as required.

It is advisable to start at a low speed when using the whisk.

WORKING POSITION

• MIXER OPERATION

Hold the blender firmly by the handle and the bottom of the motor unit and tilt it at a slight angle. Move the mixer around in the container for complete processing. The power mixer can be rested against the rim of the container but must be tilted so that it does not touch the bottom of the container.

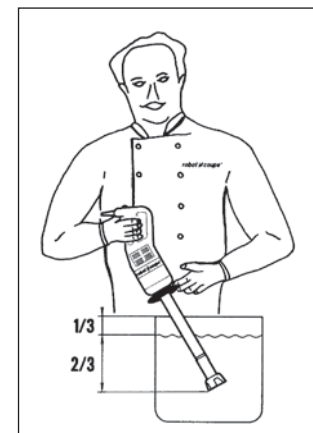

If using the power mixer support (optional accessory), on the top of the container, the power mixer should be positioned in the middle of the support and at a slight angle. **Do not operate the power mixer with the bell straight up-and-down against the bottom of the container.**

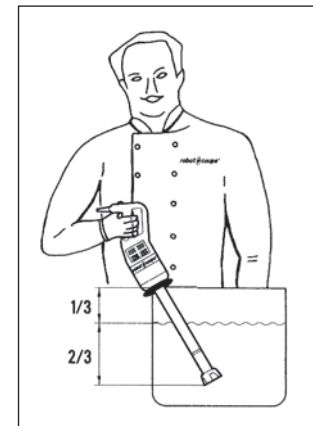

The splashguard should always be in place.

Always make sure that the bell is completely immersed to avoid splashing and that the ventilation openings in the motor housing do not come into contact with any liquid!

For optimum efficiency two thirds (2/3) of the tube should be immersed in the product.

• WHISK OPERATION

We recommend that you hold the power mixer by the handle and the bottom of the motor unit.

You can also hold the appliance by the handle with one hand, leaving the other hand free to hold the bowl, if necessary.



While processing we recommend that you move the whisk around in the bowl, in order to ensure that the mixture is completely homogeneous. We strongly advise you to keep the whisk from touching the sides of the bowl. For maximum efficiency, at least one-fifth of the whisk length should be immersed. We also strongly advise you to start the processing at a low speed.

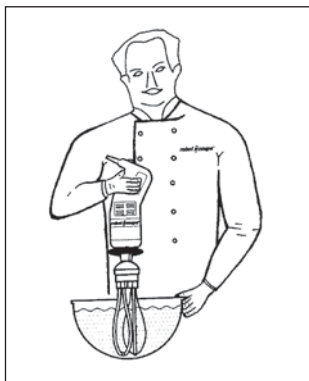

ASSEMBLY / DISASSEMBLY

- BLADE

- **Attaching the tube to the motor unit.**
(only for CMP Combi)

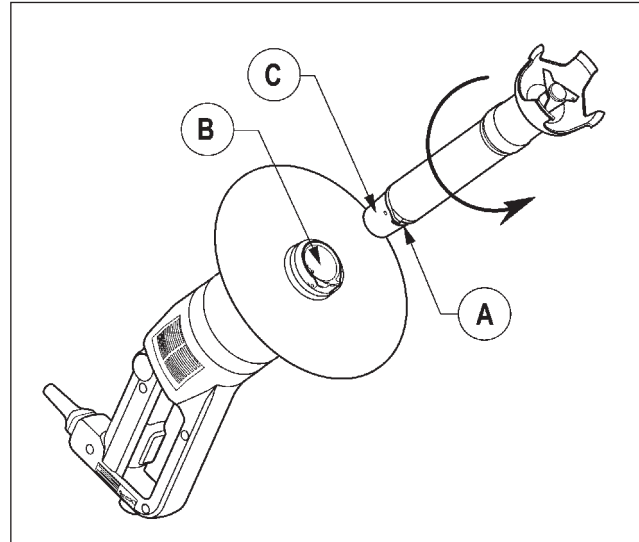

- Unplug the machine then, align the flat side of the conical part of the tube with catch in the aluminum casing.
- Insert the narrow portion of conical part of the tube into the aluminum casing.
- Turn the tube in the direction of the arrow (see figure) until it is snugly in place.

• **Removing the tube from the casing**

- Unplug the power mixer.
- Turn the tube in the opposite direction of that used to attach it.
- When it will not go any further, remove the tube from the conical part.

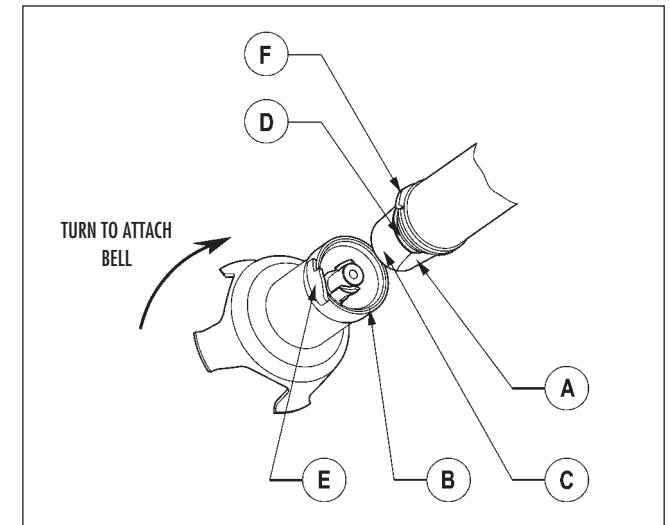

• **Attaching the bell to the tube**

- Unplug the power mixer.
- Align the flat side of the conical part of the tube with catch on the inside of the bell.
- Insert the conical part into the bell. With the washer touching the tube seal, turn the bell in the direction of the arrow (See figure) to lock the bell lug and tube lug snugly together.

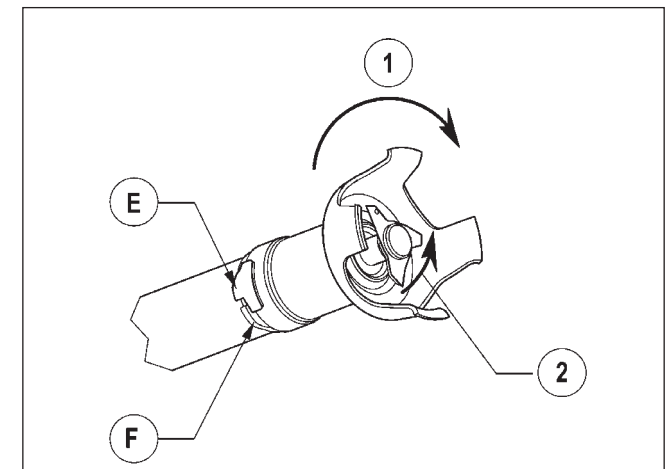

- **Removing the bell from the tube**

- **Unplug the power mixer.**

- Turn the bell in the direction of the arrow (see next figure) to separate the bell lug from the tube lug.

- Remove the bell.

If jammed, turn the blades inside the bell in the direction of the arrow to loosen them from the drive shaft.

- **Removing the blades**

- **Unplug the power mixer** then, hold the blades with the provided blade-locking tool.

- Using the blade-locking tool, unscrew the drive coupling then remove the blade for easy cleaning.

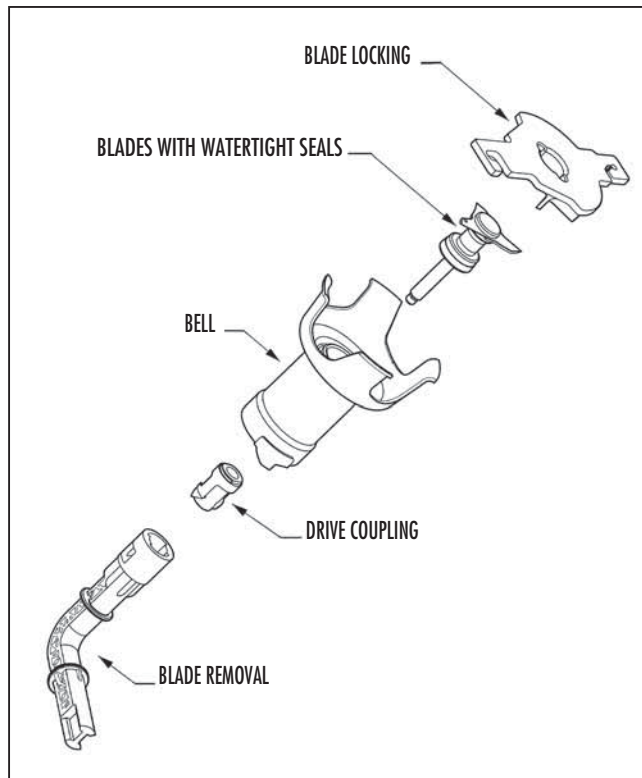

- **WHISK**

- **Attaching the whisk holder to the motor unit**
(only for CMP Combi)

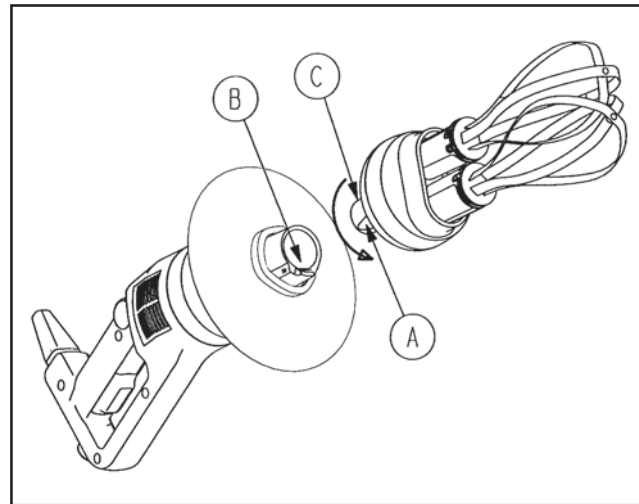

- **Unplug the power mixer.**

- Align the flat side of the conical part of the whisk holder with the catch on the inside of the aluminum casing.

- Insert the conical part of the whisk holder into the aluminum casing.

- Turn the whisk holder in the direction of the arrow (see figure) until it is snugly locked into place.

- **Removing the casing**

- **Unplug the power mixer.**

- Turn the whisk holder in the opposite direction from that used to attach it.

- When it will go no further, remove the whisk holder from the aluminum casing.

- **Fitting the whisk into the whisk holder**

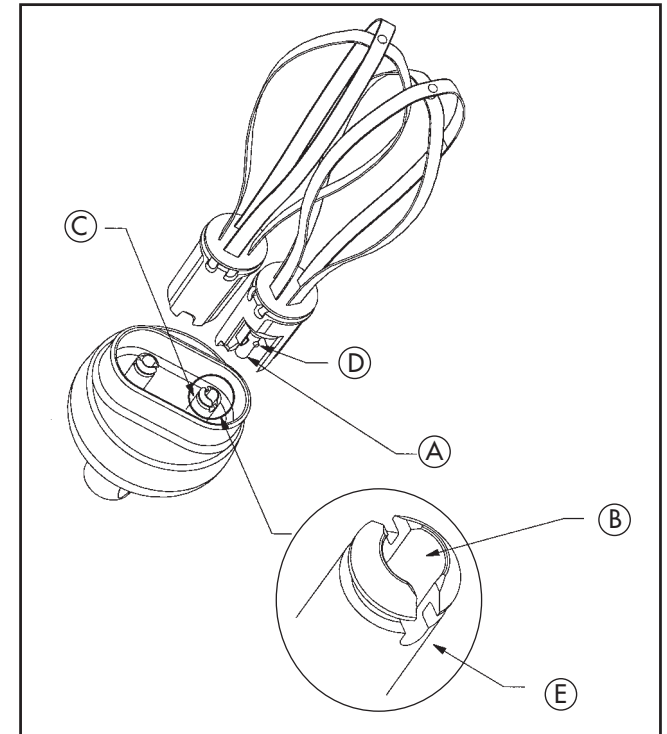

- Grasp the holder in one hand.

- With the other hand, take the first whisk and insert the shaft into the bore of the whisk holder drive shaft. Make sure the drive lugs are properly aligned with the notches.

- As you push the whisk into the holder drive shaft, rotate it slightly in order to slide the drive lugs into the notches of the drive shaft, thereby locking the whisk into place inside the shaft.

- To check that the whisk is properly fixed inside the shaft, gently pull the metal wires.

- Repeat this procedure with the second whisk. If you cannot push it in properly, remove it, rotate it 90° and start again.

• Removing the whisk from the whisk holder

While gripping the ejector in one hand and the holder in the other, pull the ejector in the opposite direction of the arrow.

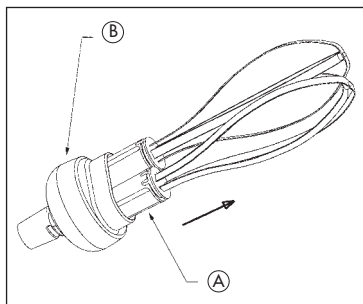

• Removing the ejector

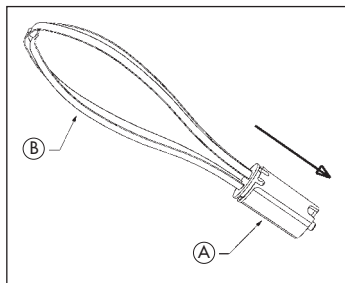

Hold the whisk by the wires in one hand. With the other hand, pull the ejector in the direction of the arrow (see figure).

SPLASH GUARD ASSEMBLY

- Put the screw back on the ring and tighten it.

Cover the ring with the splash guard protection sliding it all along the foot in the arrow direction, the flange must be oriented down.

Be careful: align the front sides of the two parts.

- To remove the splash guard protection for cleaning follow these instructions in the reverse order.

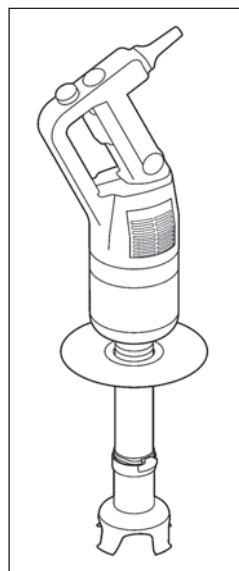

CLEANING



WARNING

- Always unplug the power mixer before cleaning it!
- Always dilute bleach according to the instructions on the label
- Never run the motor assembly through a dish machine.
- The type and concentration of the sanitation agent must comply with 21 CFR 178.1010 regulations.
- Clean according to local health department regulations.

• MOTOR HOUSING

The power mixer must be clean through all stages of production. Clean between each job using a detergent or disinfectant. Dilute the detergent / disinfectant following the instructions normally specified on it's packaging container. Use a cloth **lightly dampened (not dripping)** with the cleaning solution. **Do not allow liquid to come into contact with the electrical components contained within the housing. Be careful when cleaning around vents do not allow liquid to drip or seep into the housing.** Use a cloth lightly dampened (not dripping) with water to remove detergent/disinfectant then dry using a clean cloth.

After using the power mixer in a hot mixture, cool the bottom of the tube in cold water before disassembling the bell from the tube.

Clean immediately after use to prevent product from sticking to surfaces.



WARNING

Never immerse motor housing and/or handle in liquid! The housing contains the electrical components and is not sealed against liquid. Contact with liquid can cause damage to the blender and serious injury to the operator.

• TUBE AND BELL

There are two ways to proceed:

Simple cleaning procedure

Submerge the tube and bell in water and run for a few seconds to clean. Unplug the power cord.

Complete cleaning procedure

Unplug the power mixer and rinse the bell under a water tap. Remove the bell from the tube, then remove the blade (**wear cutting gloves**) ! Be careful to avoid damaging the surface of the blade shaft and the watertight seals. Always dilute the detergent/disinfectant (see above). Thoroughly dry all parts before reassembling.

• BLADE

The blade can be removed from the bell for thorough cleaning. Always dry thoroughly to avoid spotting.

• ALUMINUM

Use soft-metal-safe cleaning agents!

• PLASTIC

Be careful, many cleaning agents are corrosive and are not safe for use on plastics!

Do not use strong alkaline detergent (having a high concentration of soda or ammonia).

• WHISK HOLDER

Never immerse the whisk holder in water. Clean it with a cloth lightly dampened (not dripping). Never run the whisk holder through a dishwasher.

• WHISKS

The whisks can be cleaned either by hand or in a dishwasher.

To ensure effective cleaning, always remove the whisk ejector.

MAINTENANCE

• BLADE

Over time the blades will become worn and will need to be replaced. The washer and seals should also be replaced at this time. A blade service kit is available.

• TUBE SEAL

In order to maintain a watertight seal between the tube and bell, inspect the seal for wear and replace it if necessary.

• SEAL RING

The seal ring can be lubricated using a suitable food grade grease. In order to maintain a watertight seal, check the seal ring for wear and replace it if necessary.

• WHISKS

The performance of the whisks depends on the condition of the wires. The metal wires may become worn over time. In order to ensure optimum performance, they will need to be replaced. **Do not use a defective or damaged whisk!**

TROUBLE SHOOTING

• THE POWER MIXER DOES NOT START.

- Did you follow the previous operating instructions? See section-Operating The Power Mixer.
- Is the machine too hot? Allow the power mixer to cool. Then retry.

- Pull the plug and try another outlet.
- Check outlet for current (breaker or fuse).
- Call local Robot Coupe authorized service agency.

• THE POWER MIXER STOPS DURING (WHILE) PROCESSING.

See the section on Operating the power Mixer. The first paragraph describes the overload protection. It may be necessary to allow the machine to cool for up to 30 minutes before restarting.

If you cannot locate the cause of the problem

- Release the control button (CB).
 - Unplug the power mixer.
 - Are the blades free to rotate in the bell?
 - Is the drive shaft free to rotate? To check this, unplug the power mixer, remove the bell and test the rotation of the end of the drive shaft manually.
- Check the condition of the plug and the power cord.

• THE POWER MIXER STARTS TO SMELL HOT OR SMOKE.

Turn the power mixer off and unplug it. Call your local authorized service agency.

! WARNING

- **THE BLADES ARE SHARP!** It is recommended that cutting gloves be worn when handling the blades. Handle and store the blades with safety in mind.
- **Never try to defeat the safety mechanisms!**
- **Never put anything (utensils etc.) but food material near the blades on the power mixer!**
- **Never overload the power mixer!**
- **Never turn the power mixer on unless the bell is completely immersed in the product.**
- **Always unplug the power mixer before doing any cleaning or maintenance!**

SERVICE

See warranty first then;

Should your unit require service, check with your distributor to see where local service is available. If not or if you wish your unit to be serviced at the factory, call for return instructions and ship the unit prepaid to our factory address.

PH : 1-800-824-1646

Robot-Coupe USA, Inc
Service Department Repair
264 South Perkins Street
Ridgeland, MS 39157

For service in Canada contact the Robot-Coupe USA factory for repair instructions.

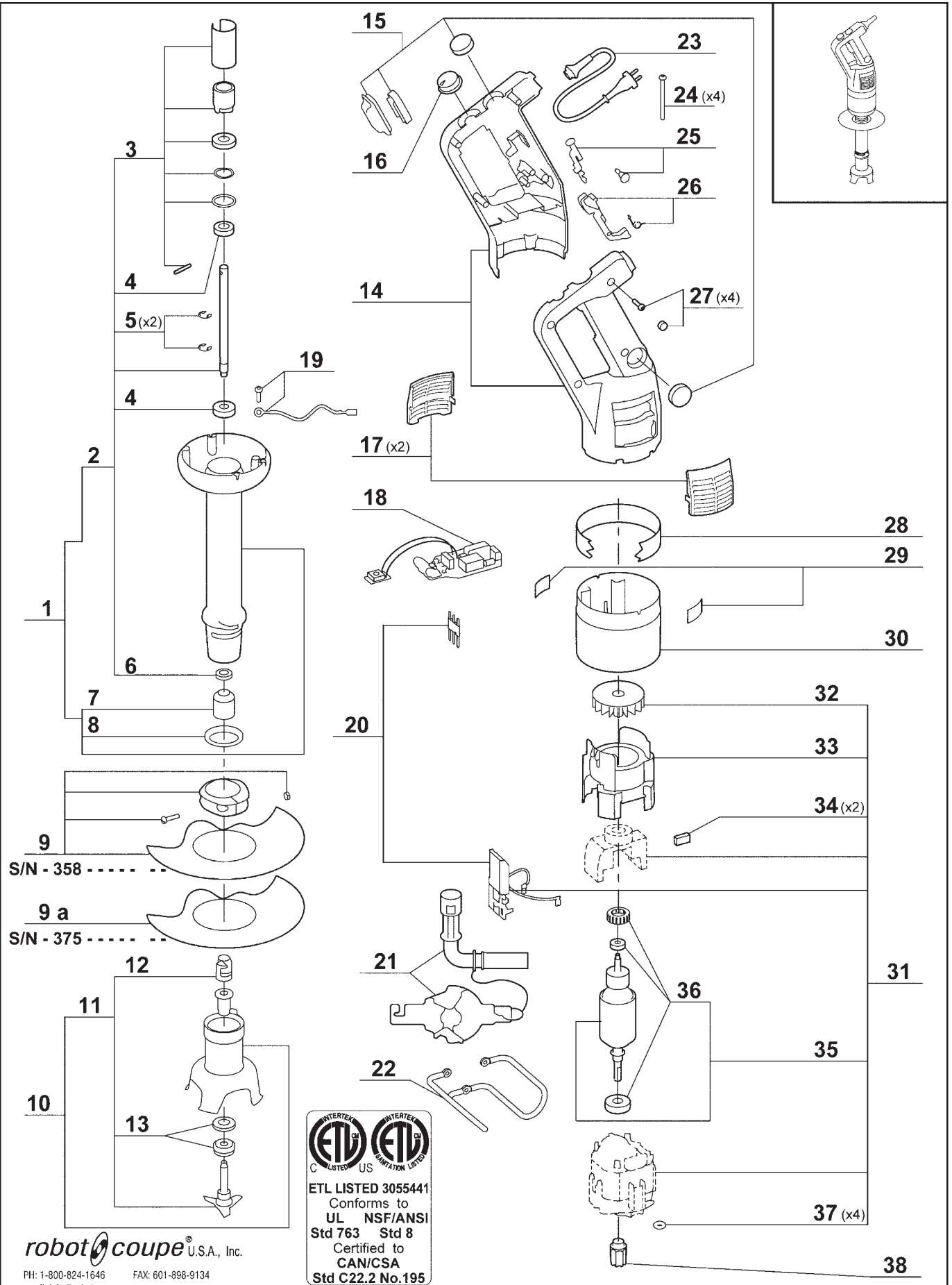



ETL LISTED 3055441
 Conforms to
UL NSF/ANSI
Std 763 Std 8
 Certified to
CAN/CSA
Std C22.2 No.195

Index	Pièce / Part	Description	Désignation
1	89 652	CMP 250 FOOT	PIED EQUIPE CMP 250
2	89 685	CMP250 DRIVING SHAFT	ARBRE D'ENTRAINEMENT CMP 250
3	89 643	MPC/CMP/CMPC FOOT KIT	KIT PIED MPC/CMP/CMPC
4	89 645	STAINL ST BEAR 608 2RS	ROULEMENT INOX 608 2RS
5	89 647	RING "E" (x2)	ANNEAU "E" (x2)
6	89 646	SEAL 8x18x5	JOINT A LEVRE 8x18x5
7	89 626	MP/CMP DRIVING FRAME	CAGE D'ENTRAINEMENT MP/CMP
8	89 628	FOOT SEAL	JOINT DE PIED MP/CMP
9	89 635	CMP NSF PROTECTION	PROTECTION NSF CMP
9a	89 106	CMP "A" NSF PROTECTION	PROTECTION NSF CMP "A"
10	89 678	CMP BELL COVER	CLOCHE CMP EQUIPEE
11	89 676	CMP BLADE	COUTEAU CMP
12	89 627	MP/CMP DRIVING HUB	MOYEU D'ENTRAINEMENT MP/CMP
13	89 642	SEAL RING	GARNITURE D'ETANCHEITE
14	89 547	CMP HANDLES (L+R) KIT+SCREW+ CAP SCREW CMP	KIT POIGNEES (G+D)+VIS+CACHE CMP
15	89 533	MP/CMP WATERPROOFNESS KIT+SCREW+CAP SCREW	KIT ETANCHEITE MP/CMP+VIS+CACHE VIS
16	89 536	MP/CMP VARIATOR SWITCH+SCREW+CAP SCREW	BOUTON VARIATEUR MP/CMP.+VIS+CACHE VIS
17	89 546	CMP VENT COVERS KIT (x2)	KIT GRILLES CMP (x2)
18	89 752	CMP 120V CIRC BOARD- SCREW+CAP SCREW	PLATINE CMP 120V- VIS+CACHE VIS
19	89 638	CMP GROUND WIRING KIT	KIT FIL TERRE CMP
20	89 548	KIT CONNECTOR+SCREW+CAP SCREW	KIT CONNECTION CMP+VIS+CACHE VIS
21	89 662	MP/CMP DISMOUNT TOOL	OUTILLAGE DE DEMONTAGE MP/CMP
22	89 637	CMP WALL SUPPORT	SUPPORT MURAL CMP
23	89 541	MPC/CMP 120V POWER CORD+SCREW+CAP SCREW	CABLE ALIM MPC/CMP 120V+VIS+CACHE VIS
24	89 623	CMP SCREW M4x95 (x4)	VIS M4x95 CMP (x4)
25	89 530	MP/CMP KNOBS KIT +SCREW+CAP SCREW KIT	KIT BOUTON MP/CMP+VIS+CACHE VIS
26	89 531	MPC/CMP COMMAND ARM KIT+SCREW+CAP SCREW	KIT LEVIER CDE MPC/CMP+VIS+CACHE VIS
27	89 532	MP/CMP HANDLE SCREW (x4)	KIT VIS POIG MP/CMP (x4)
28	89 605	CMP 250 VV FERRULE	VIROLE CMP 250 V.V.
29	89 636	ADHESIVE SECURED LABEL	KIT ETIQUETTES AVERTS
30	89 612	CMP MOTOR FERRULE	VIROLE MOTEUR CMP
31	89 769	CMP250 120V MOTOR	MOTEUR CMP250 120V
32	89 576	CMP VENTILATOR	VENTILATEUR CMP
33	89 570	CMP VENTILATOR PIPE	CONDUIT VENTILATEUR CMP
34	89 575	CMP BRUSHES (x2)	CHARBONS CMP (x2)
35	89 760	CMP 120V INDUCED CIRC	INDUIT CMP 120V
36	89 679	CMP MOTOR BEARING	ROULEMENT MOTEUR CMP
37	89 639	SEAL Ø2x1,5 (x4)	JOINT TORIQUE Ø2x1,5 (x4)
38	89 632	MPC DRIVING HUB	MOYEU D'ENTRAINEMENT MPC

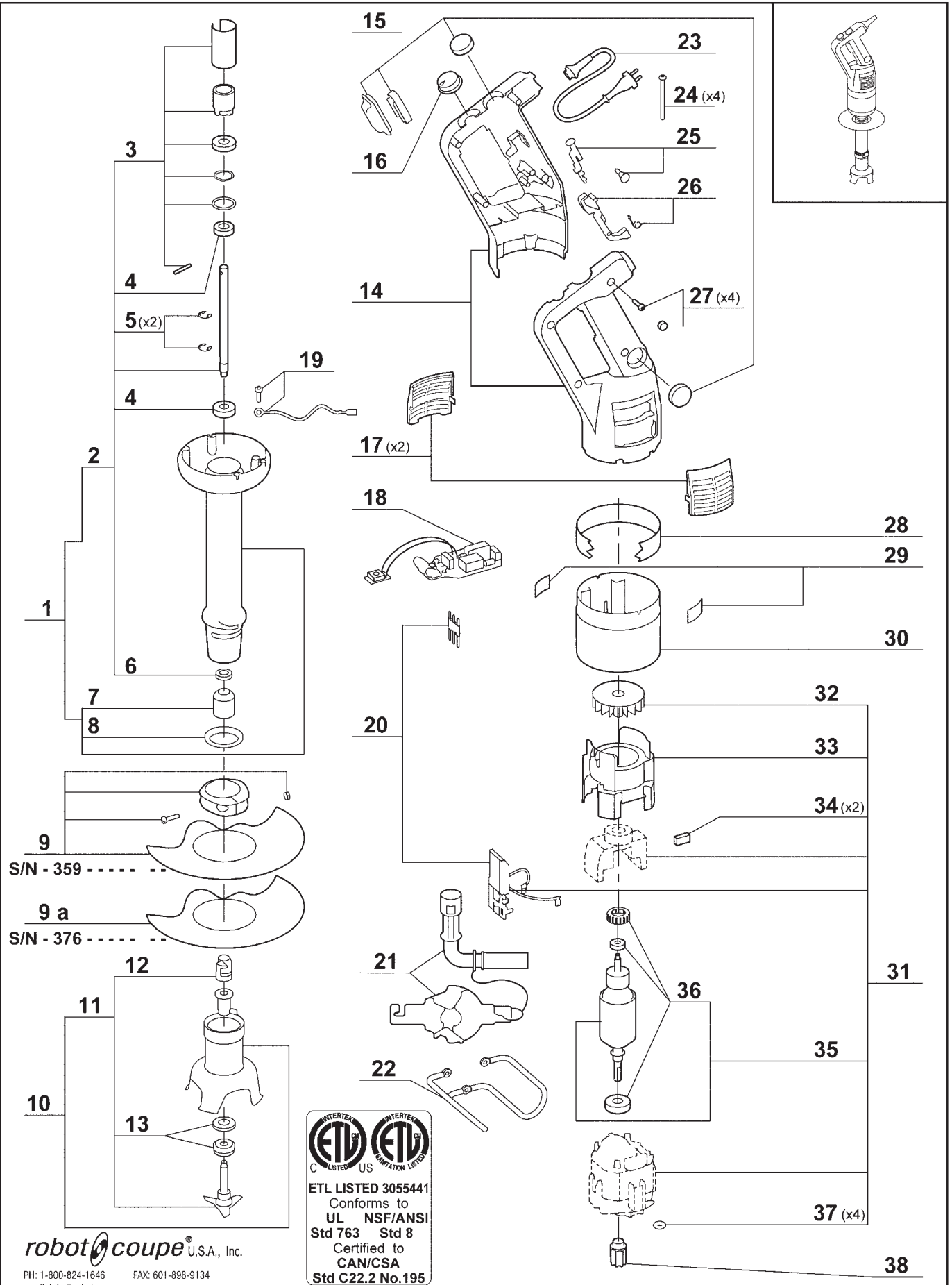

<i>Index</i>	<i>Pièce / Part</i>	<i>Description</i>	<i>Désignation</i>
1	89 653	CMP 300 FOOT	PIED EQUIPE CMP 300
2	89 686	CMP 300 DRIVING SHAFT	ARBRE D'ENTRAINEMENT CMP 300
3	89 643	MPC/CMP/CMPC FOOT KIT	KIT PIED MPC/CMP/CMPC
4	89 645	STAINL ST BEAR 608 2RS	ROULEMENT INOX 608 2RS
5	89 647	RING "E" (x2)	ANNEAU "E" (x2)
6	89 646	SEAL 8x18x5	JOINT A LEVRE 8x18x5
7	89 626	MP/CMP DRIVING FRAME	CAGE D'ENTRAINEMENT MP/CMP
8	89 628	FOOT SEAL	JOINT DE PIED MP/CMP
9	89 635	CMP NSF PROTECTION	PROTECTION NSF CMP
9a	89 106	CMP "A" NSF PROTECTION	PROTECTION NSF CMP "A"
10	89 678	CMP BELL COVER	CLOCHE CMP EQUIPEE
11	89 676	CMP BLADE	COUTEAU CMP
12	89 627	MP/CMP DRIVING HUB	MOYEU D'ENTRAINEMENT MP/CMP
13	89 642	SEAL RING	GARNITURE D'ETANCHEITE
14	89 547	CMP HANDLES (L+R) KIT+SCREW+ CAP SCREW CMP	KIT POIGNEES (G+D)+VIS+CACHE CMP
15	89 533	MP/CMP WATERPROOFNESS KIT+SCREW+CAP SCREW	KIT ETANCHEITE MP/CMP+VIS+CACHE VIS
16	89 536	MP/CMP VARIATOR SWITCH+SCREW+CAP SCREW	BOUTON VARIATEUR MP/CMP.+VIS+CACHE VIS
17	89 546	CMP VENT COVERS KIT (x2)	KIT GRILLES CMP (x2)
18	89 752	CMP 120V CIRC BOARD- SCREW+CAP SCREW	PLATINE CMP 120V- VIS+CACHE VIS
19	89 638	CMP GROUND WIRING KIT	KIT FIL TERRE CMP
20	89 548	KIT CONNECTOR+SCREW+CAP SCREW	KIT CONNECTION CMP+VIS+CACHE VIS
21	89 662	MP/CMP DISMOUNT TOOL	OUTILLAGE DE DEMONTAGE MP/CMP
22	89 637	CMP WALL SUPPORT	SUPPORT MURAL CMP
23	89 541	MPC/CMP 120V POWER CORD+SCREW+CAP SCREW	CABLE ALIM MPC/CMP 120V+VIS+CACHE VIS
24	89 623	CMP SCREW M4x95 (x4)	VIS M4x95 CMP (x4)
25	89 530	MP/CMP KNOBS KIT +SCREW+CAP SCREW KIT	KIT BOUTON MP/CMP+VIS+CACHE VIS
26	89 531	MPC/CMP COMMAND ARM KIT+SCREW+CAP SCREW	KIT LEVIER CDE MPC/CMP+VIS+CACHE VIS
27	89 532	MP/CMP HANDLE SCREW (x4)	KIT VIS POIG MP/CMP (x4)
28	89 606	CMP 300 VV FERRULE	VIROLE CMP 300 V.V.
29	89 636	ADHESIVE SECURED LABEL	KIT ETIQUETTES AVERTS
30	89 612	CMP MOTOR FERRULE	VIROLE MOTEUR CMP
31	89 762	CMP300 120V MOTOR	MOTEUR CMP300 120V
32	89 576	CMP VENTILATOR	VENTILATEUR CMP
33	89 570	CMP VENTILATOR PIPE	CONDUIT VENTILATEUR CMP
34	89 575	CMP BRUSHS (x2)	CHARBONS CMP (x2)
35	89 760	CMP 120V INDUCED CIRC	INDUIT CMP 120V
36	89 679	CMP MOTOR BEARING	ROULEMENT MOTEUR CMP
37	89 639	SEAL Ø2x1,5 (x4)	JOINT TORIQUE Ø2x1,5 (x4)
38	89 632	MPC DRIVING HUB	MOYEU D'ENTRAINEMENT MPC

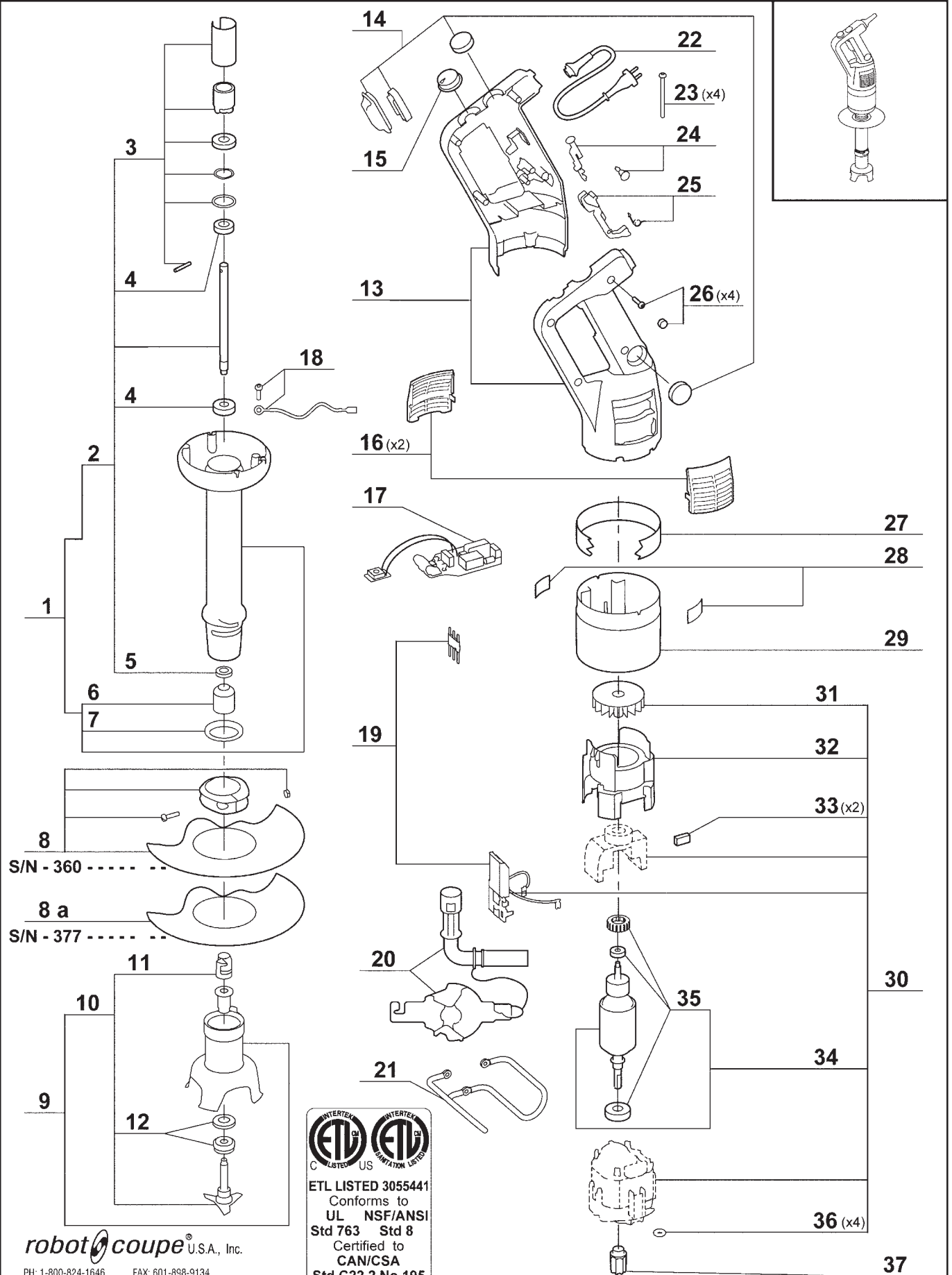



ETL LISTED 3055441
 Conforms to
UL NSF/ANSI
Std 763 Std 8
 Certified to
CAN/CSA
Std C22.2 No.195

Index	Pièce / Part	Description	Désignation
1	89 654	CMP 350 FOOT	PIED EQUIPE CMP 350
2	89 687	CMP 350 DRIVING SHAFT	ARBRE D'ENTRAINEMENT CMP 350
3	89 643	MPC/CMP/CMPC FOOT KIT	KIT PIED MPC/CMP/CMPC
4	89 645	STAINL ST BEAR 608 2RS	ROULEMENT INOX 608 2RS
5	89 646	SEAL 8x18x5	JOINT A LEVRE 8x18x5
6	89 626	MP/CMP DRIVING FRAME	CAGE D'ENTRAINEMENT MP/CMP
7	89 628	FOOT SEAL	JOINT DE PIED MP/CMP
8	89 635	CMP NSF PROTECTION	PROTECTION NSF CMP
8a	89 106	CMP "A" NSF PROTECTION	PROTECTION NSF CMP "A"
9	89 678	CMP BELL COVER	CLOCHE CMP EQUIPEE
10	89 676	CMP BLADE	COUTEAU CMP
11	89 627	MP/CMP DRIVING HUB	MOYEU D'ENTRAINEMENT MP/CMP
12	89 642	SEAL RING	GARNITURE D'ETANCHEITE
13	89 547	CMP HANDLES (L+R) KIT+SCREW+ CAP SCREW CMP	KIT POIGNEES (G+D)+VIS+CACHE CMP
14	89 533	MP/CMP WATERPROOFNESS KIT+SCREW+CAP SCREW	KIT ETANCHEITE MP/CMP+VIS+CACHE VIS
15	89 536	MP/CMP VARIATOR SWITCH+SCREW+CAP SCREW	BOUTON VARIATEUR MP/CMP.+VIS+CACHE VIS
16	89 546	CMP VENT COVERS KIT (x2)	KIT GRILLES CMP (x2)
17	89 752	CMP 120V CIRC BOARD- SCREW+CAP SCREW	PLATINE CMP 120V- VIS+CACHE VIS
18	89 638	CMP GROUND WIRING KIT	KIT FIL TERRE CMP
19	89 548	KIT CONNECTOR+SCREW+CAP SCREW	KIT CONNECTION CMP+VIS+CACHE VIS
20	89 662	MP/CMP DISMOUNT TOOL	OUTILLAGE DE DEMONTAGE MP/CMP
21	89 637	CMP WALL SUPPORT	SUPPORT MURAL CMP
22	89 541	MPC/CMP 120V POWER CORD+SCREW+CAP SCREW	CABLE ALIM MPC/CMP 120V+VIS+CACHE VIS
23	89 623	CMP SCREW M4x95 (x4)	VIS M4x95 CMP (x4)
24	89 530	MP/CMP KNOBS KIT +SCREW+CAP SCREW KIT	KIT BOUTON MP/CMP+VIS+CACHE VIS
25	89 531	MPC/CMP COMMAND ARM KIT+SCREW+CAP SCREW	KIT LEVIER CDE MPC/CMP+VIS+CACHE VIS
26	89 532	MP/CMP HANDLE SCREW (x4)	KIT VIS POIG MP/CMP (x4)
27	89 607	CMP 350 VV FERRULE	VIROLE CMP 350 V.V.
28	89 636	ADHESIVE SECURED LABEL	KIT ETIQUETTES AVERTS
29	89 612	CMP MOTOR FERRULE	VIROLE MOTEUR CMP
30	89 770	CMP350 120V MOTOR	MOTEUR CMP350 120V
31	89 576	CMP VENTILATOR	VENTILATEUR CMP
32	89 570	CMP VENTILATOR PIPE	CONDUIT VENTILATEUR CMP
33	89 575	CMP BRUSHS (x2)	CHARBONS CMP (x2)
34	89 760	CMP 120V INDUCED CIRC	INDUIT CMP 120V
35	89 679	CMP MOTOR BEARING	ROULEMENT MOTEUR CMP
36	89 639	SEAL Ø2x1,5 (x4)	JOINT TORIQUE Ø2x1,5 (x4)
37	89 632	MPC DRIVING HUB	MOYEU D'ENTRAINEMENT MPC

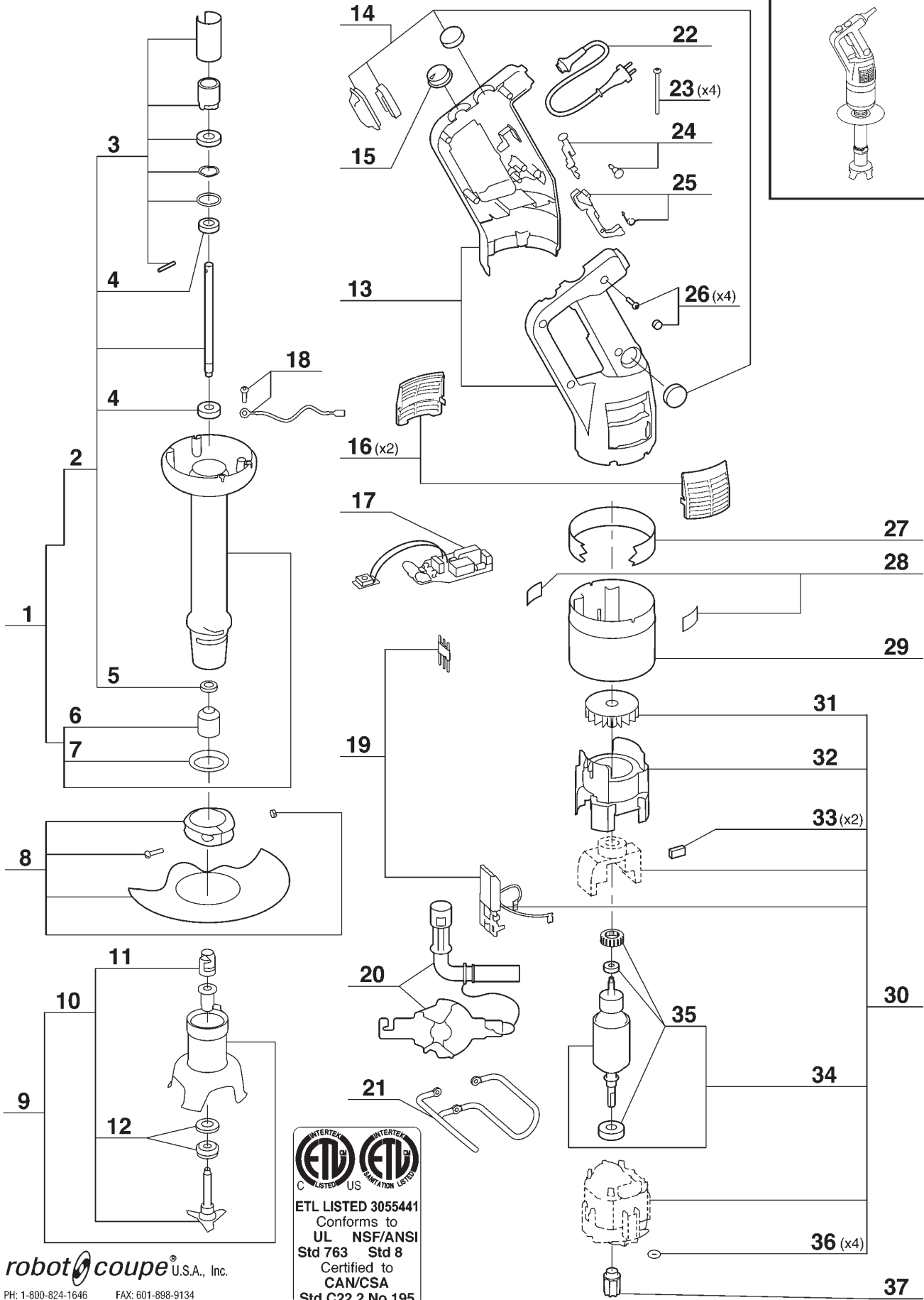
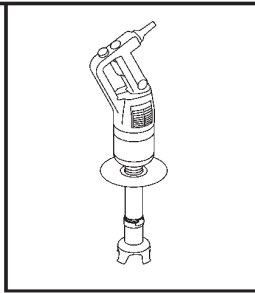



ETL LISTED 3055441
 Conforms to
UL NSF/ANSI
Std 763 Std 8
 Certified to
CAN/CSA
Std C22.2 No.195

<i>Index</i>	<i>Pièce / Part</i>	<i>Description</i>	<i>Désignation</i>
1	89 655	CMP 400 FOOT	PIED EQUIPE CMP 400
2	89 151	CMP 400 DRIVING SHAFT	ARBRE D'ENTRAINEMENT CMP 400
3	89 643	MPC/CMP/CMPC FOOT KIT	KIT PIED MPC/CMP/CMPC
4	89 645	STAINL ST BEAR 608 2RS	ROULEMENT INOX 608 2RS
5	89 646	SEAL 8x18x5	JOINT A LEVRE 8x18x5
6	89 626	MP/CMP DRIVING FRAME	CAGE D'ENTRAINEMENT MP/CMP
7	89 628	FOOT SEAL	JOINT DE PIED MP/CMP
8	89 635	CMP NSF PROTECTION	PROTECTION NSF CMP
9	89 678	CMP BELL COVER	CLOCHE CMP EQUIPEE
10	89 676	CMP BLADE	COUTEAU CMP
11	89 627	MP/CMP DRIVING HUB	MOYEU D'ENTRAINEMENT MP/CMP
12	89 642	SEAL RING	GARNITURE D'ETANCHEITE
13	89 547	CMP HANDLES (L+R) KIT+SCREW+ CAP SCREW CMP	KIT POIGNEES (G+D)+VIS+CACHE CMP
14	89 533	MP/CMP WATERPROOFNESS KIT+SCREW+CAP SCREW	KIT ETANCHEITE MP/CMP+VIS+CACHE VIS
15	89 536	MP/CMP VARIATOR SWITCH+SCREW+CAP SCREW	BOUTON VARIATEUR MP/CMP.+VIS+CACHE VIS
16	89 546	CMP VENT COVERS KIT (x2)	KIT GRILLES CMP (x2)
17	89 752	CMP 120V CIRC BOARD- SCREW+CAP SCREW	PLATINE CMP 120V- VIS+CACHE VIS
18	89 638	CMP GROUND WIRING KIT	KIT FIL TERRE CMP
19	89 548	KIT CONNECTOR+SCREW+CAP SCREW	KIT CONNECTION CMP+VIS+CACHE VIS
20	89 662	MP/CMP DISMOUNT TOOL	OUTILLAGE DE DEMONTAGE MP/CMP
21	89 637	CMP WALL SUPPORT	SUPPORT MURAL CMP
22	89 541	MPC/CMP 120V POWER CORD+SCREW+CAP SCREW	CABLE ALIM MPC/CMP 120V+VIS+CACHE VIS
23	89 623	CMP SCREW M4x95 (x4)	VIS M4x95 CMP (x4)
24	89 530	MP/CMP KNOBS KIT +SCREW+CAP SCREW KIT	KIT BOUTON MP/CMP+VIS+CACHE VIS
25	89 531	MPC/CMP COMMAND ARM KIT+SCREW+CAP SCREW	KIT LEVIER CDE MPC/CMP+VIS+CACHE VIS
26	89 532	MP/CMP HANDLE SCREW (x4)	KIT VIS POIG MP/CMP (x4)
27	89 608	CMP 400 VV FERRULE	VIOLE CMP 400 V.V.
28	89 636	ADHESIVE SECURED LABEL	KIT ETIQUETTES AVERTS
29	89 612	CMP MOTOR FERRULE	VIOLE MOTEUR CMP
30	89 771	CMP400 120V MOTOR	MOTEUR CMP400 120V
31	89 576	CMP VENTILATOR	VENTILATEUR CMP
32	89 570	CMP VENTILATOR PIPE	CONDUIT VENTILATEUR CMP
33	89 575	CMP BRUSHS (x2)	CHARBONS CMP (x2)
34	89 760	CMP 120V INDUCED CIRC	INDUIT CMP 120V
35	89 679	CMP MOTOR BEARING	ROULEMENT MOTEUR CMP
36	89 639	SEAL Ø2x1,5 (x4)	JOINT TORIQUE Ø2x1,5 (x4)
37	89 632	MPC DRIVING HUB	MOYEU D'ENTRAINEMENT MPC

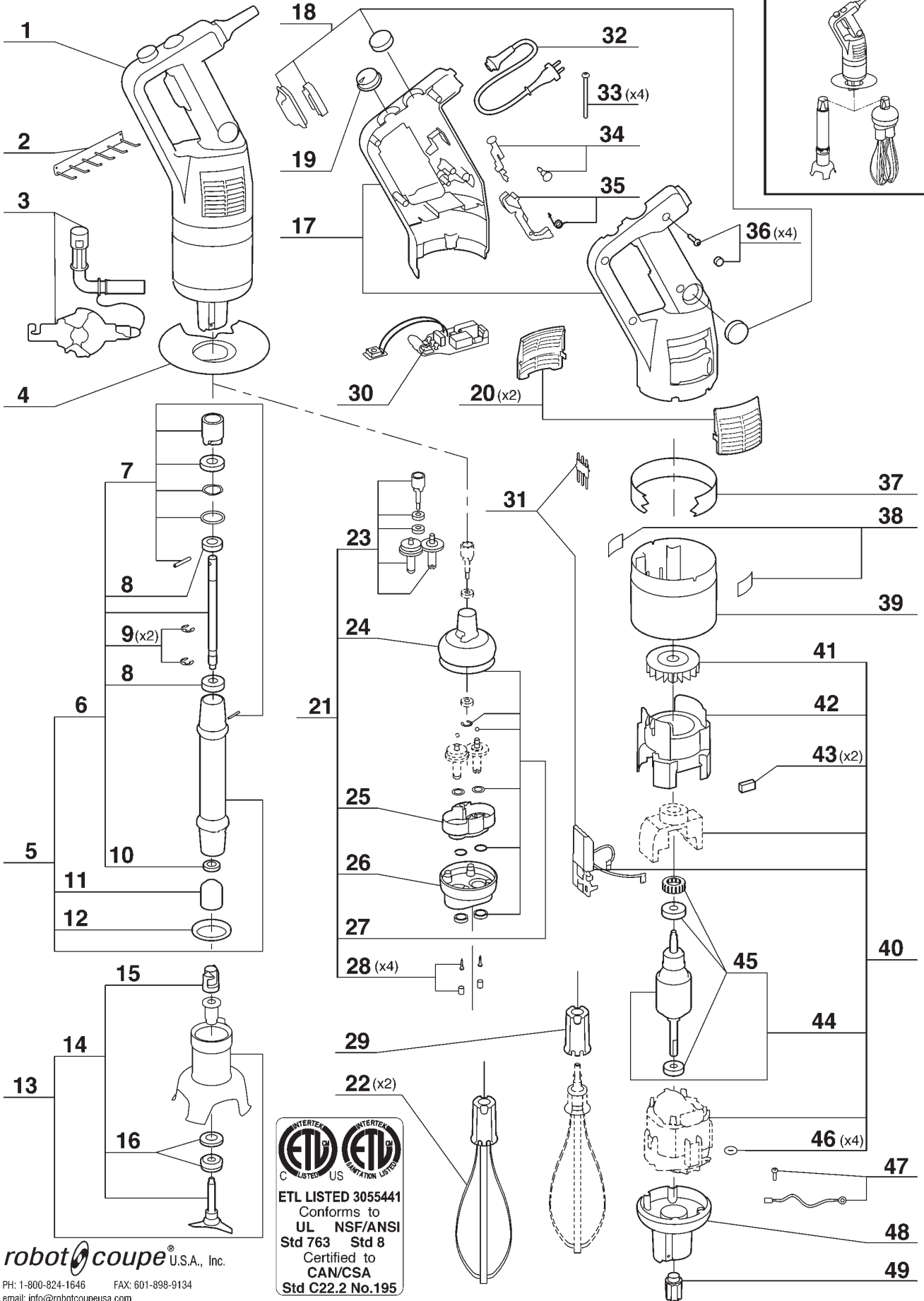

<i>Index</i>	<i>Pièce / Part</i>	<i>Description</i>	<i>Désignation</i>
1	29 802	BLOCK MOTOR	BLOCK MOTEUR COMPLET
2	89 630	MPC WALL SUPPORT	SUPPORT MURAL MPC
3	89 662	MP/CMP DISMOUNT TOOL	OUTIL DE DEMONTAGE MP/CMP
4	89 635	CMP NSF PROTECTION	PROTECTION NSF CMP
5	89 656	CMPC250 FOOT	PIED CMPC 250 EQUIPE
6	89 811	CMPC250 DRIVING SHAFT	ARBRE ENTRAINEMENT CMPC250
7	89 643	MPC/CMP/CMPC FOOT KIT	KIT PIED MPC/CMP/CMPC
8	89 645	BEARING 608 2RS	ROULEMENT 608 2RS
9	89 647	RING "E" (x2)	ANNEAU "E" (x2)
10	89 646	SEAL 8x18x5	JOINT A LEVRE 8x18x5
11	89 626	MP/CMP DRIVING FRAME	CAGE D'ENTRAINEMENT MP/CMP
12	89 628	MP/CMP FOOT SEAL	JOINT DE PIED MP/CMP
13	89 678	CMP BELL COVER	CLOCHE CMP EQUIPEE
14	89 676	CMP BILADE	COUTEAU CMP
15	89 627	MP/CMP DRIVING HUB	MOYEU D'ENTRAINEMENT MP/CMP
16	89 642	SEAL RING	GARNITURE D'ETANCHEITE
17	89 547	HANDCMP HANDLES L+R KIT+SCREW+CAP SCREW CMP	KIT POIGNEES G+D CMP+VIS+CACHE CMP
18	89 533	MP/CMP WATERPROOFNESS KIT+CAP SCREW KIT	KIT ETANCHEITE MP/CMP+VIS+CACHE VIS
19	89 536	BOUTON VARIATEUR MP/CMP+SCREW+CAP SCREW	BOUTON VARIATEUR EQU.+VIS+CACHE VIS
20	89 546	CMP VENT COVERS KIT (x2)	KIT GRILLES CMP (x2)
21	89 651	CMP WHIP BOX	BOITE FOUET CMP
22	89 649	CMP WHIPS (x2)	FOUETS CMP (x2)
23	89 549	BF CMP GEARS RING BEAR+SCREW+CAP SCREW KIT	PIGNONS RLT BAG BF CMP+VIS+CACHE-VIS B.F.
24	89 379	MP/CMP BF UPPER BODY	COQUE SUP BF MP/CMP
25	89 385	PLATE+SCREW+CAP SCREW	FLASQUE+VIS+CACHE-VIS
26	89 746	BF CMP LOWER BODY PLASTIC	COQUE INF PLASTIQUE BF CMP
27	89 545	BF SEAL WASHER KIT+SCREW+CAP SCREW KIT	KIT JOINT RONDELLE BF+VIS+CACHE VIS
28	89 389	BF SCREW+CAP SCREW	VIS+CACHE VIS BF MP/CMP
29	89 552	MP/CMP WHIP EJECTOR	KIT EJECT FOUET MP/CMP
30	89 752	CMP 120V CIRC BOARD+SCREW+CAP SCREW KIT	PLATINE CMP 120V+VIS+CACHE VIS
31	89 548	CMP CONNECTOR KIT	KIT CONNECTION CMP
32	89 541	MPC/CMP 120V POWER CORD+SCREW+CAP SCREW	CABLE ALIM MPC/CMP 120V+VIS+CACHE VIS
33	89 623	CMP SCREW M4x95	VIS M4x95 CMP
34	89 530	MP/CMP KNOBS KIT+SCREW+CAP SCREW	KIT BOUTON MP/CMP+VIS+CACHE VIS
35	89 531	MP/CMP COMMAND ARM KIT +SCREW+CAP SCREW	KIT LEVIER COMMANDE MP/CMP+VIS+CACHE VIS
36	89 532	MP/CMP HANDLE SCREW KIT (x4)	KIT VIS POIG MP/CMP (x4)
37	89 609	CMPC250 FERRULE	VIROLE CMPC250
38	89 636	ADHESIVE SECURED LABEL	KIT ETIQUETTES AVERTS
39	89 612	CMP MOTOR FERRULE	VIROLE MOTEUR CMP
40	89 769	CMP250 120V MOTOR	MOTEUR CMP250 120V
41	89 576	CMP VENTILATOR	VENTILATEUR CMP
42	89 570	CMP VENTILATOR PIPE	CONDUIT VENTILATEUR CMP
43	89 575	CMP BRUSHES (x2)	CHARBONS CMP (x2)
44	89 760	CMP 120V INDUCED CIRC	INDUIT CMP 120V
45	89 679	CMP MOT BEARING	ROULEMENT MOTEUR CMP
46	89 639	SEAL Ø2x1,5 x4 (x4)	JOINT TORIQUE Ø2x1,5 x4 (x4)
47	89 638	CMP GROUND WIRING KIT	KIT FIL TERRE CMP
48	89 641	CMP ALUMINIUM CASING	CARTER ALU CMP
49	89 661	CMPC DRIVING HUB	MOYEU ENTRAINEMENT CMPC

robotcoupe® U.S.A., Inc.

CMP 300 Combi

Serial number - 162 - - - - -
Serial number - 374 - - - - -

120 Volt, 60Hz, 3,2 Amps

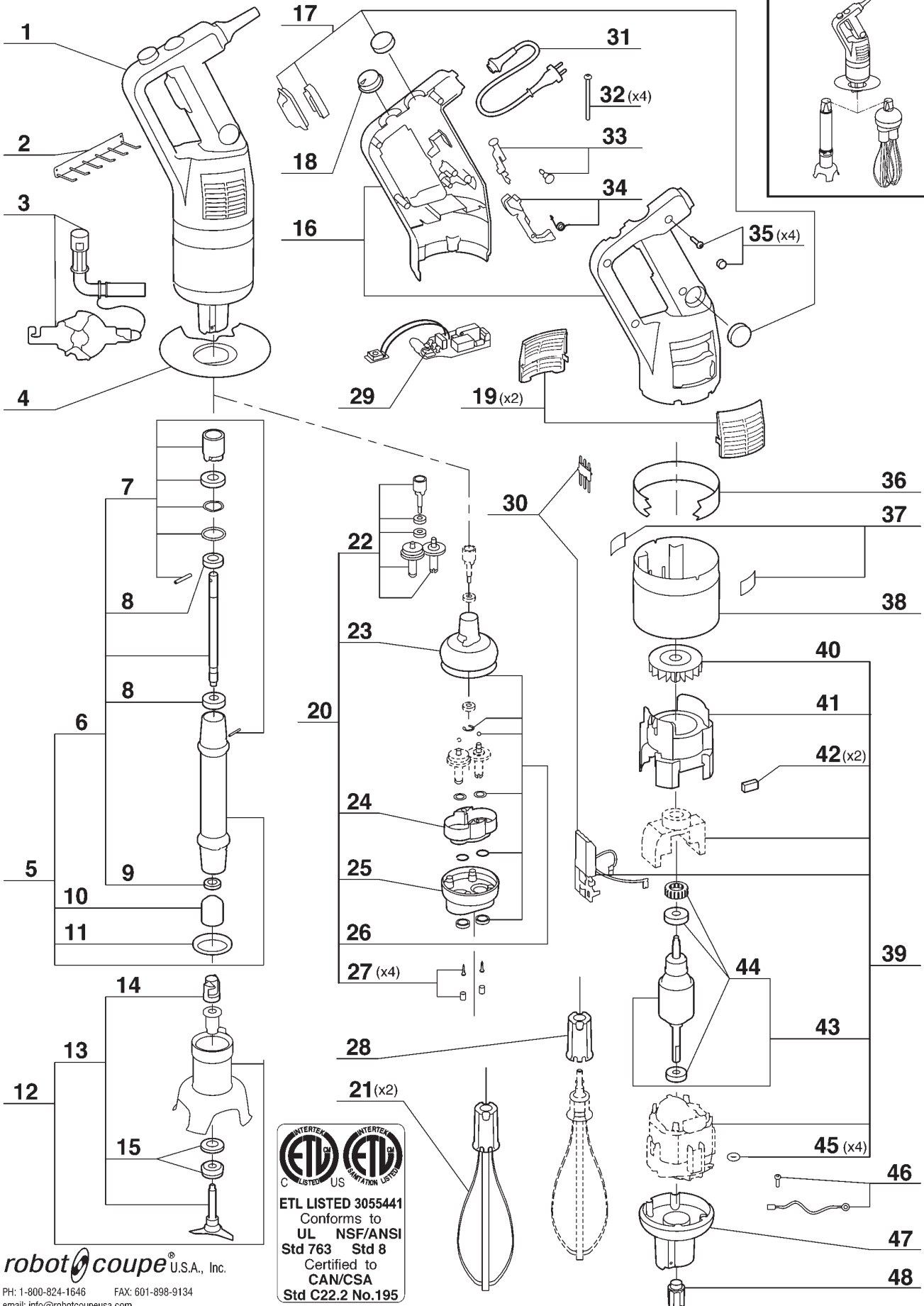

robotcoupe® U.S.A., Inc.

PH: 1-800-824-1646 FAX: 601-898-9134
email: info@robotcoupeusa.com

ETL LISTED 3055441
Conforms to
UL NSF/ANSI
Std 763 Std 8
Certified to
CAN/CSA
Std C22.2 No.195

Index	Pièce / Part	Description	Désignation
1	29 803	BLOCK MOTOR	BLOCK MOTEUR COMPLET
2	89 630	MPC WALL SUPPORT	SUPPORT MURAL MPC
3	89 662	MP/CMP DISMOUNT TOOL	OUTIL DE DEMONTAGE MP/CMP
4	89 635	CMP NSF PROTECTION	PROTECTION NSF CMP
5	89 657	CMPC300 FOOT	PIED CMPC300 EQUIPE
6	89 812	CMPC300 DRIVING SHAFT	ARBRE ENTRAINEMENT CMPC300
7	89 643	MPC/CMP/CMPC FOOT KIT	KIT PIED MPC/CMP/CMPC
8	89 645	BEARING 608 2RS	ROULEMENT 608 2RS
9	89 646	SEAL 8x18x5	JOINT A LEVRE 8x18x5
10	89 626	MP/CMP DRIVING FRAME	CAGE D'ENTRAINEMENT MP/CMP
11	89 628	MP/CMP FOOT SEAL	JOINT DE PIED MP/CMP
12	89 678	CMP BELL COVER	CLOCHE CMP EQUIPEE
13	89 676	CMP BILADE	COUTEAU CMP
14	89 627	MP/CMP DRIVING HUB	MOYEU D'ENTRAINEMENT MP/CMP
15	89 642	SEAL RING	GARNITURE D'ETANCHEITE
16	89 547	HANDCMP HANDLES L+R KIT+SCREW+CAP SCREW CMP	KIT POIGNEES G+D CMP+VIS+CACHE CMP
17	89 533	MP/CMP WATERPROOFNESS KIT+CAP SCREW KIT	KIT ETANCHEITE MP/CMP+VIS+CACHE VIS
18	89 536	BOUTON VARIATEUR MP/CMP+SCREW+CAP SCREW	BOUTON VARIATEUR EQU.+VIS+CACHE VIS
19	89 546	CMP VENT COVERS KIT (x2)	KIT GRILLES CMP (x2)
20	89 651	CMP WHIP BOX	BOITE FOUET CMP
21	89 649	CMP WHIPS (x2)	FOUETS CMP (x2)
22	89 549	BF CMP GEARS RING BEAR+SCREW+CAP SCREW KIT	PIGNONS RLT BAG BF CMP+VIS+CACHE-VIS B.F.
23	89 379	MP/CMP BF UPPER BODY	COQUE SUP BF MP/CMP
24	89 385	PLATE+SCREW+CAP SCREW	FLASQUE+VIS+CACHE-VIS
25	89 746	BF CMP LOWER BODY PLASTIC	COQUE INF PLASTIQUE BF CMP
26	89 545	BF SEAL WASHER KIT+SCREW+CAP SCREW KIT	KIT JOINT RONDELLE BF+VIS+CACHE VIS
27	89 389	BF SCREW+CAP SCREW	VIS+CACHE VIS BF MP/CMP
28	89 552	MP/CMP WHIP EJECTOR	KIT EJECT FOUET MP/CMP
29	89 752	CMP 120V CIRC BOARD+SCREW+CAP SCREW KIT	PLATINE CMP 120V+VIS+CACHE VIS
30	89 548	CMP CONNECTOR KIT	KIT CONNECTION CMP
31	89 541	MPC/CMP 120V POWER CORD+SCREW+CAP SCREW	CABLE ALIM MPC/CMP 120V+VIS+CACHE VIS
32	89 623	CMP SCREW M4x95	VIS M4x95 CMP
33	89 530	MP/CMP KNOBS KIT+SCREW+CAP SCREW	KIT BOUTON MP/CMP+VIS+CACHE VIS
34	89 531	MP/CMP COMMAND ARM KIT +SCREW+CAP SCREW	KIT LEVIER COMMANDE MP/CMP+VIS+CACHE VIS
35	89 532	MP/CMP HANDLE SCREW KIT (x4)	KIT VIS POIG MP/CMP (x4)
36	89 610	CMPC300 FERRULE	VIOLE CMPC300
37	89 636	ADHESIVE SECURED LABEL	KIT ETIQUETTES AVERTS
38	89 612	CMP MOTOR FERRULE	VIOLE MOTEUR CMP
39	89 762	CMP300 120V MOTOR	MOTEUR CMP300 120V
40	89 576	CMP VENTILATOR	VENTILATEUR CMP
41	89 570	CMP VENTILATOR PIPE	CONDUIT VENTILATEUR CMP
42	89 575	CMP BRUSHES (x2)	CHARBONS CMP (x2)
43	89 760	CMP 120V INDUCED CIRC	INDUIT CMP 120V
44	89 679	CMP MOT BEARING	ROULEMENT MOTEUR CMP
45	89 639	SEAL Ø2x1,5 x4 (x4)	JOINT TORIQUE Ø2x1,5 x4 (x4)
46	89 638	CMP GROUND WIRING KIT	KIT FIL TERRE CMP
47	89 641	CMP ALUMINIUM CASING	CARTER ALU CMP
48	89 661	CMPC DRIVING HUB	MOYEU ENTRAINEMENT CMPC

CMP250 V.V. - CMP300 V.V. - CMP350 V.V. - CMP400 V.V. - CMP250 Combi - CMP300 Combi

120V/60Hz 1~

ELECTRIC DIAGRAM

SCHEMA ELECTRIQUE

ESQUEMA CONEXIONES

	English	Français	Espanol
A	Aluminium housing	Capot aluminium	Carter aluminio
C	Control unit	Unité de contrôle	Unidad de control
M	Motor	Moteur	Motor
P	Potentiometer	Potentiomètre	Potenciometro
SW1	On/off switch	Interrupteur marche/arrêt	Interruptor marcha/parada
T	Triac	Triac	Triac
θ	Thermal protector	Protecteur thermique	Protector termico

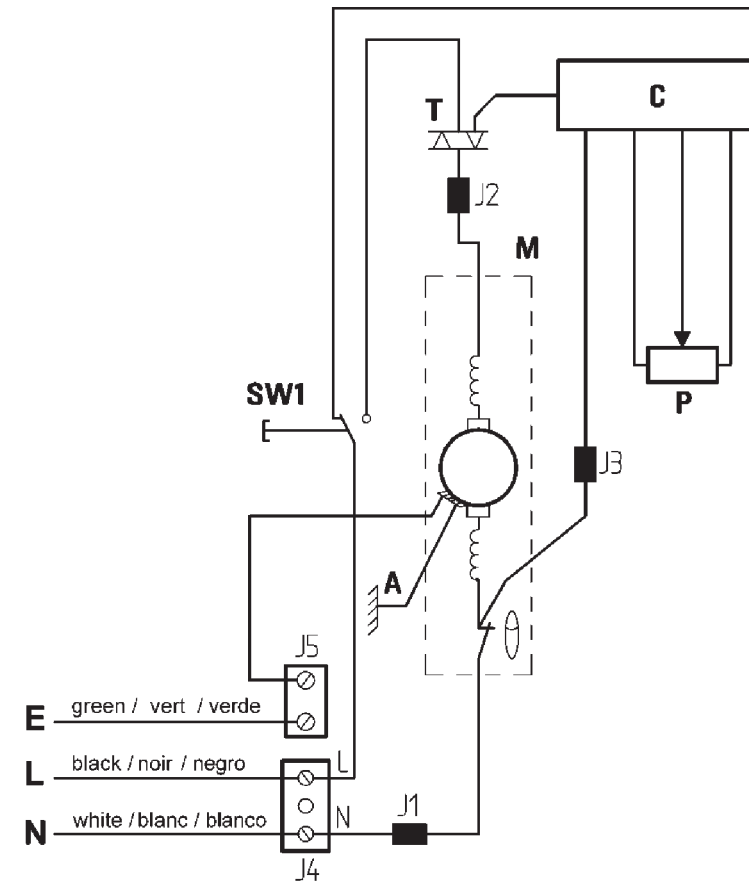
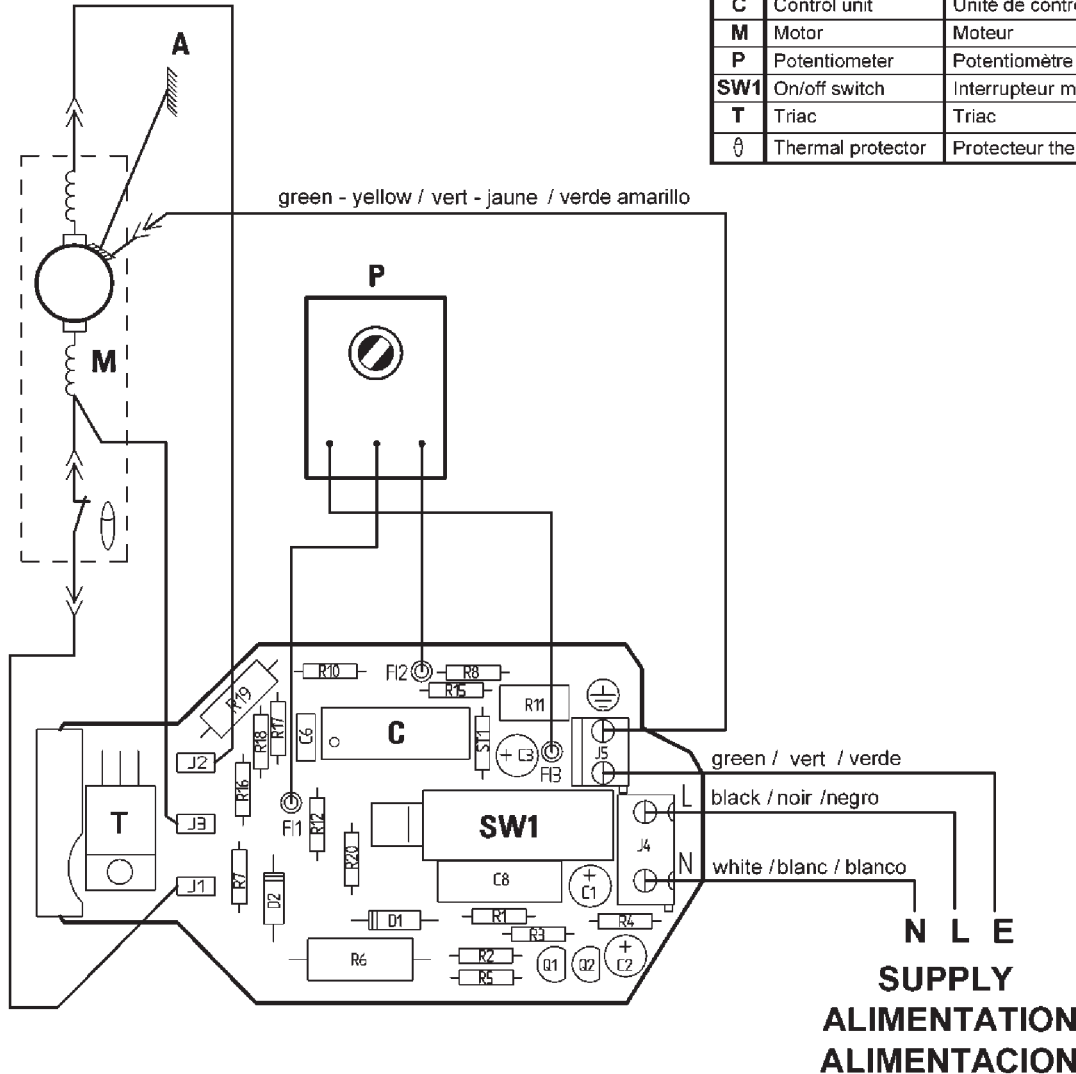



robot coupe[®]

Robot-coupe USA. Inc.

P.O. Box 16625, Jackson, MS 39236-6625

264 South Perkins St., Ridgeland, MS 39157

e-mail: info@robotcoupeusa.com

website: www.robotcoupeusa.com

Phone : 1-800-824-1646