

# *robot* *coupe*®



## **J80 Ultra • J100 Ultra**

**Robot-coupe USA, Inc.**

P.O. Box 16625, Jackson, MS 39236-6625 - 264 South Perkins St., Ridgeland, MS 39157  
e-mail: [info@robotcoupeusa.com](mailto:info@robotcoupeusa.com) - website: [www.robotcoupeusa.com](http://www.robotcoupeusa.com) - Phone : 1-800-824-1646

# CONTENTS

■	WARRANTY	■	CLEANING
■	IMPORTANT WARNING	■	TECHNICAL SPECIFICATIONS
■	YOU HAVE JUST ACQUIRED A CENTRIFUGAL JUICER J80 Ultra • J100 Ultra	■	SAFETY
■	SWITCHING ON THE MACHINE	■	TROUBLESHOOTING
■	ASSEMBLY J80 Ultra	■	SERVICE
■	ASSEMBLY J100 Ultra	■	RECIPES
■	DIFFERENT CONFIGURATIONS	■	TECHNICAL DATA
■	RECOMMENDATIONS FOR USE		<ul style="list-style-type: none"><li>• Electrical diagram</li><li>• Parts diagram</li><li>• 39910 basket assembly sheet</li></ul>

# ROBOT COUPE USA. Inc. LIMITED WARRANTY

**YOUR NEW ROBOT COUPE PRODUCT IS WARRANTED TO THE ORIGINAL PURCHASER FOR A PERIOD OF ONE YEAR FROM THE DATE OF PURCHASE.**

**This LIMITED WARRANTY is against defects in the material and/or workmanship, and includes labor for replacement of defective parts, provided repairs are performed by an authorized Service Agency.**

**The Customer must inform the Service Agency of the possibility of warranty coverage and provide a copy of the dated sales or delivery receipt BEFORE WARRANTY REPAIRS ARE BEGUN.**

**Replacement parts and accessories are warranted for ninety (90) days from the date of purchase when purchased separately and will be verified by dated sales receipt OR packing slip which lists that item.**

**All parts or accessories replaced under warranty must be returned to the Service Agency.**

## **THE FOLLOWING ARE NOT COVERED BY THE ROBOT COUPE USA. Inc. LIMITED WARRANTY:**

- 1** - Damage caused by abuse, misuse, dropping, or other similar damage caused by or resulting from failure to follow assembly, operating, cleaning, user maintenance or storage instructions.
- 2** - Labor to sharpen and/or replacements for blades that have become blunt, chipped or worn after a normal or excessive period of use.
- 3** - Materials or labor to replace or repair scratched, stained, chipped, pitted, dented or discolored surfaces, blades, knives, attachments or accessories.
- 4** - Any alteration, addition, or repair that has not been carried out by the company or an approved Service Agency.
- 5** - Transportation of the appliance to or from an approved Service Agency.
- 6** - Labor charges to install or test new attachments or accessories (i.e., bowls, plates, blades, attachments), which have been replaced for any reason.

**7** - The cost of changing direction-of-rotation of three-phase electric motors (Installer is responsible).

**8** - SHIPPING DAMAGES. Visible and/or hidden damage is the responsibility of the freight carrier. The consignee must inform the carrier and consignor immediately, or upon discovery in the case of hidden defects.

**KEEP ALL ORIGINAL CONTAINERS AND PACKING MATERIALS FOR CARRIER INSPECTION.**

Neither ROBOT COUPE USA. Inc. nor its affiliated companies or any of its distributors, directors, agents, employees, or insurers will be liable for indirect damage, losses, or expenses linked to the appliance or the inability to use it.

**The ROBOT COUPE USA. Inc. warranty is given expressly and in lieu of all other warranties, expressed or implied, for merchantability and for fitness toward a particular purpose and constitutes the only warranty made by ROBOT COUPE USA. Inc.**

# IMPORTANT WARNING



**WARNING:** In order to limit accidents such as electric shocks, personal injury or fire, and in order to limit material damage due to misuse of the appliance, please read these instructions carefully and follow them strictly. Reading the operating instructions will help you get to know your appliance and enable you to use the equipment correctly. The operation manual should be kept within easy access to all users for reference and should be read completely by all first time users of the machine.

## UNPACKING

- Carefully remove the appliance from its packaging, together with all the boxes or packets containing the accessories or specific items of equipment.
- **WARNING:** the blades and discs are extremely sharp.

## INSTALLATION

- We recommend that you install your appliance on a clean and completely stable countertop at a comfortable working height.

## CONNECTION

- Always check that your power supply corresponds to that indicated on the serial number plate and that it is properly sized.

## ASSEMBLY PROCEDURES

- Make sure you follow the assembly instructions in the right order (see following pages) and check that all the accessories are correctly positioned.

## USE

- **Never remove the lid until the motor and basket have come to a complete standstill.**

- **Never insert anything other than fruit or vegetables into the feed tube.**
- **The lid of your appliance features a unique Auto Feed system. Simply feed the fruit or vegetables into the tube and let the machine do the rest.**
- **If a blockage occurs inside the feed tube, NEVER use any object other than the pusher to clear it.**
- **Never insert your hand into the ejection chute. If the ejector becomes blocked, switch your J 80 Ultra/J 100 Ultra juicer off and wash the lid under the tap.**
- **Never leave the machine running unattended.**

## CLEANING

- **Always unplug your machine before cleaning.**
- **Always clean the machine and attachments at the end of each use.**
- **Never clean the machine with a pressure washer or foam lance.**
- **Never place the motor unit in water.**
- **Be sure to use the appropriate detergent for each part (stainless steel or plastic).**

- **For plastic parts, do not use detergents that are too alkaline (i.e., containing too much caustic soda or ammonia...).**
- **The bowl, lid and pulp container are all dishwasher-safe. However, to prolong their lifespan, we advise hand-washing them with a domestic washing-up liquid.**
- **Robot Coupe can in no way be held responsible for the user's failure to follow the basic rules of cleaning and maintenance.**

## MAINTENANCE

- **Always unplug the appliance before servicing.**
- **The watertightness of the motor shaft needs to be monitored on a regular basis. At the same time, check that the safety system is working properly.**
- **WARNING: never switch your appliance on if the power cord or plug has been damaged.**
- **If the appliance is not working properly or has been damaged in any way, unplug it and have it overhauled.**
- **Do not hesitate to call your ROBOT-COUCPE-approved after-sales service if you notice a fault.**

## YOU HAVE JUST ACQUIRED A CENTRIFUGAL JUICER J80 Ultra • J100 Ultra

Stable and sturdy, the **J80 Ultra/J100 Ultra** juicer can produce **any number of 100% natural juices on demand** and in next to no time!

The **J80 Ultra/J100 Ultra** juicer is ideal for making fresh juices from vegetables and locally grown or exotic fruit, as well as sophisticated cocktails, all totally pure and natural.

It therefore has applications in bars, restaurants, canteens, institutions and day nurseries, as well as in healthcare settings and in the production of dietetic foods, where fresh fruit and vegetable juices play a key role.

Fruit and vegetables, especially when they are raw, represent a valuable source of the vitamins, minerals and fibers our bodies need to stay healthy. Vegetable juices contain mainly mineral salts, while fruit juices are packed full of vitamins to boost our energy.

### MINERAL SALTS

Not all foods contain the same mineral salts.

Some minerals, such as potassium, magnesium, sulphur and sodium chloride (salt) are so widespread that a varied diet will always ensure a sufficient intake. For some minerals, however, it is useful to know which are the best sources.

**Calcium** : fruit and green vegetables.

**Phosphorus** : pulses.

**Potassium** : fresh vegetables.

**Iron** : spinach, parsley.

**Iode** : all plants.

### TABLE OF VITAMINS IN FRUIT

Vitamins	B1	C	A	D
Apple	•	•		•
Apricot	•	•	•	•
Blackberry	•	•	•	•
Blackcurrant	•	•		•
Cherry	•	•	•	•
Grape	•	•		•
Grapefruit	•	•	•	•
Kiwi fruit	•	•	•	•
Lemon	•	•	•	•
Melon	•	•		•
Orange	•	•	•	•
Peach	•	•		•
Pear	•	•		•
Pineapple	•	•	•	•
Plum	•	•		•
Raspberry	•	•		•
Redcurrant	•	•		•
Strawberry	•	•		•

### TABLE OF VITAMINS IN VEGETABLES

Vitamins	B1/B6	A	E	K
Asparagus	•		•	
Cabbage	•	•	•	•
Carrot	•	•	•	
Celeriac	•			
Celery		•	•	•
Chicory	•			
Courgette	•	•	•	
Cucumber	•	•	•	
Fennel	•		•	
Lettuce	•		•	
Onion	•			
Parsley	•	•	•	
Pepper	•	•	•	
Spinach	•	•	•	•
Tomato	•	•		
Turnip	•			
Watercress	•	•	•	

Your appliance's straightforward design means that the parts which most frequently need to be handled for cleaning or aftercare can be removed in no time at all.

To make life even easier for you, these instructions guide you through each of the assembly operations, broken down into simple steps.

These instructions for use contain important information aimed at enabling users to derive the maximum benefit from their juicer.

**We therefore strongly advise you to read through them carefully before you start to use your appliance.**

## SWITCHING ON THE MACHINE

Before connecting your appliance to the mains, check that the voltage of your power supply matches that indicated on your appliance's identification plate.

The **J80 Ultra/J100 Ultra** juicer is equipped with a power cord fitted with a standard single-phase plug.

**Check the machine carefully on arrival to ensure that it has not been damaged during transport or unpacking.**

Pay particular attention to the power cord and plug.



## WARNING

**THIS APPLIANCE MUST BE PLUGGED INTO AN EARTHED SOCKET (RISK OF ELECTROCUTION).**

# ASSEMBLY J80 Ultra

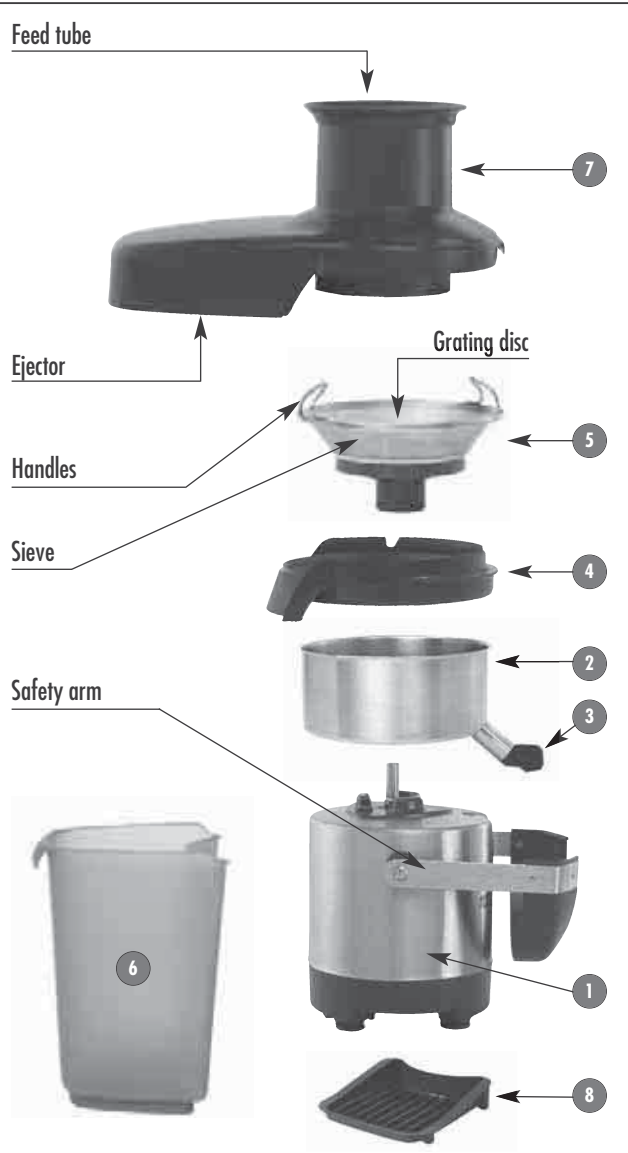

1) Position the motor unit so that the On/Off buttons are facing you.



2) Place the bowl on top of the motor unit.



3) Fit the flange onto the rim of the bowl. The ribs of the flange should be lined up with the flat panel of the bowl. Check that the flange is correctly fitted.



4) Lower the basket into place, holding it by its handles. Rotate it until it slots into place.



5) Line the lid up with the notches in the flange

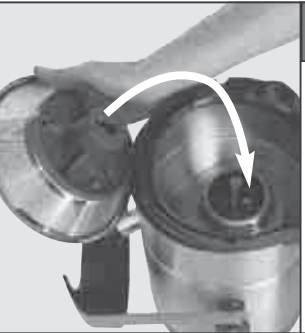

**IMPORTANT**  
Make sure that the pin on the motor shaft is correctly lined up with the corresponding notch in the basket hub.

You can also refer to the label (below) stuck to the lid.





6) Position the **pulp container**.



7) Close the safety arm.

To start the machine, press the On button 1. The juicer will not start unless the safety arm has been closed properly (safety switch).

Place a jug underneath the spout. Your juicer is now ready to go!

# ASSEMBLY J 100 Ultra



1) Position the motor unit so that the On/Off buttons are facing you.



2) Place the bowl on top of the motor unit.



3) Fit the flange onto the rim of the bowl. The ribs of the flange should be lined up with the flat panel of the bowl. Check that the flange is correctly fitted.



4) Lower the basket into place, holding it by its handles. Rotate it until it slots into place.



5) Line the lid up with the notches in the flange

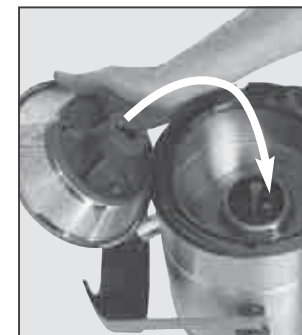

## IMPORTANT

Make sure that the pin on the motor shaft is correctly lined up with the corresponding notch in the basket hub.

You can also refer to the label (below) stuck to the lid.





6) Two possible uses:

- **Continuous pulp ejection.**



Position the continuous **pulp ejection chute** in the hole in the booster base.

Remember to place a bin (not supplied) directly beneath this chute.

- **Ejection of pulp into the closed pulp container.**



Position **the pulp container**.



7) Close the safety arm.

To start the machine, press the On button 1. The juicer will not start unless the safety arm has been closed properly (safety switch).

Place a jug underneath the spout. Your juicer is now ready to go!

8) Using the **strap** (see page 9) - (Option)



If you have positioned your juicer on the edge of a countertop, attach the ejection chute to the **lid** using the **strap** supplied with the appliance.

## DIFFERENT CONFIGURATIONS

The **J 100 Ultra** juicer comes supplied with all the accessories you will need and is designed to adapt itself to your particular needs and work setting.

For example, it can be configured to suit the characteristics of your work station:







- Install the **booster base 10** if you are going to use tall containers to collect the juice (see page 9).
- In normal usage, you can process more than ten kilos (according to the nature of the produce) before you need to empty the **pulp container 6** (see page 9).
- For high-volume juicing, the **ejection chute 7** (see page 9) does away with the need to empty the pulp container. If you opt for this configuration, make sure you place a large bin (not supplied) directly below the chute.

There are two solutions for this configuration:

- 1) Make a **4-inch Ø** hole in the worktop through which the **ejection chute 7** can protrude (see photos opposite). This is the best solution in terms of efficient worktop organization.
- 2) Worktop edge.  
When positioning the machine on the edge of the worktop, use the markers on either side of the **booster base 10** (see page 9) as your guide.

**Warning: to avoid the risk of the machine falling off the worktop, make sure that it is correctly positioned.**

- Summary of all the different possible configurations, according to the nature of the work station and the height of the juice containers (for information only):

Container	Booster base 10 use (see p. 9)	Intensity of use	Example of use
 <p>Containers Max. height 6.3 inches</p>	Not necessary	Normal	<ul style="list-style-type: none"> <li>• With <b>pulp container 6</b> (see p. 9)</li> <li>• No worktop cutout required.</li> </ul> 
		Intensive	<ul style="list-style-type: none"> <li>• With <b>ejection chute 7</b> and <b>strap 9</b> (see p. 9)</li> <li>• Worktop edge No cutout required</li> </ul> 
 <p>Containers Max. height 9.8 inches</p>	Necessary if container more than 6.3" high	Normal	<ul style="list-style-type: none"> <li>• With <b>pulp container 6</b> (see p. 9)</li> <li>• No worktop cutout required.</li> </ul> 
		Intensive	<ul style="list-style-type: none"> <li>• With <b>ejection chute 7</b> and <b>strap 9</b> (see p. 9)</li> <li>• Worktop edge No cutout required</li> </ul> 
			<ul style="list-style-type: none"> <li>• With <b>ejection chute 7</b> (see p. 9)</li> <li>• Ejection below worktop. 4-inch hole required in worktop.</li> </ul> 

## RECOMMENDATIONS FOR USE

### • J 80 Ultra • J 100 Ultra

- Before you use your juicer for the first time, it is a good idea to wash all the parts that will come into contact with food.
- Always check that the **safety arm** has been closed before using your appliance.
- Always place a container under the spout and either **the pulp container** or **the ejection chute** under the ejector after switching your machine on but before you start feeding the fruit or vegetables in.
- Remember to peel citrus fruit before juicing.

 - **Thick-skinned fruit and vegetables (e.g. pineapples, mangoes) need to be peeled beforehand and any large pips (e.g. melon) removed. Always remove the stones of stone fruit (e.g. peaches, apricots, cherries). Strip grapes from their stalks before juicing.**

- Some foods are not suitable for processing in a juicer, due to their hard consistency (e.g. coconuts).
- **The J 80 Ultra/J 100 Ultra juicer** features a unique patented Auto Feed system which does away with the need of a pusher.
- To make the best use of your **J 80 Ultra/J 100 Ultra juicer** therefore, introduce the ingredients into the feed tube by hand (without **the pusher**), according to throughput.
- Introduce the pieces of fruit or vegetables slowly and in small quantities.
- When all the ingredients have gone through, leave the machine on for a few more seconds to extract every last drop of juice.
- Never put ice cubes or frozen fruit in the feed tube.

- The pulp may become unevenly distributed inside the basket, creating an imbalance. If your juicer starts to vibrate while juicing, switch it off and clean **the basket**. You can then resume juicing.

- Check that **the flange** and **lid** are correctly positioned.

### • J 80 Ultra

- With **the J 80 Ultra juicer**, you can make several quarts of juice without having to empty **the pulp container**.

Nonetheless, remember to check the level of the pulp in the **container** on a regular basis.

- Check that **the flange** and **lid** are correctly fitted.
- Always make sure that **the pulp container** has been properly positioned.

### • J 100 Ultra

- **J 100 Ultra with pulp container:**

You can make several quarts of juice without having to empty **the pulp container**.

Nonetheless, you should check the level of pulp in the **container** on a regular basis.

- **J 100 Ultra with ejection chute:**

**The ejection chute** (supplied with your appliance) has been designed specifically to cope with high-volume juicing. With the chute, there is no need to keep on emptying **the pulp container** while juicing.

 - **If you are using your juicer on the edge of a worktop, make sure that all its feet are firmly on the work surface. You must also organize your work station so that there is no risk of the juicer tipping over or falling off.**

**NB:** If you intend to carry out high-volume juicing every day, it is best to use **the continuous pulp ejection chute**, with or without **the booster base**.

## Fruit and vegetable preparation J 80 Ultra • J 100 Ultra

	Preparation
CARROTS	Peeled and left whole, topped and tailed. Feed in 2 or 3 at a time.
APPLES	Washed and left whole (remove stalk and any labels).
STRAWBERRIES	Remove stalks for the taste.
CITRUS FRUIT	Peel all citrus fruit. Oranges and lemons can be left whole.
PINEAPPLES	Peel and cut into eight chunks (3 cuts)
MELONS	Peel and cut into eight chunks.
TOMATOES	Washed and left whole (remove hard green core). Feed in 2 or 3 at a time.
PEPPERS	Washed and cut into quarters lengthwise, according to shape.
CELERIAC	Cut into 2.5-inch chunks
CUCUMBERS	Peeled. Cut into sections measuring approx. 6 inches long.
FENNEL	Cut into 2.5-inch chunks.
GINGER	Cut into pieces to make it easier to feed into the juicer. Do not put too many in at a time, to prevent a blockage.
GRAPES	Remove stalks to avoid bitterness.



## WARNING

**Always wash fruit and vegetables thoroughly to remove all traces of dirt and pesticides.**

## CLEANING

- Always unplug the machine before cleaning of any kind
- To rinse the machine out between two different batches of fruit, switch the machine on and pour a glass of drinking water into the feed tube.



- Clean the basket by scrubbing the outside of the filter cone with a brush or scrubber sponge to remove any pulp.

- For more thorough cleaning, remove the bowl flange beforehand.
- Always clean the entire machine after use, washing the flange, bowl, lid and pusher in hot water. Scrub with a brush using an appropriate detergent.
- To avoid damaging the parts, do not tap them against any hard surfaces.

**\*Tip:** : If the pulp has dried hard onto the basket, immerse the basket into hot water for 5-10 minutes to soften it.



## IMPORTANT

Check that your detergent is suitable for use with parts made from plastic or stainless steel. Certain highly alkaline products (e.g. with a high concentration of ammonia or caustic soda) are totally incompatible with some plastics and cause them to deteriorate very quickly.



## IMPORTANT

Never immerse the motor unit in water or any other liquid and do not spray!

Do not clean it with a foam lance or pressure washer.

If necessary, wipe the motor unit with a damp cloth.

Always unplug your machine first.

## CARACTÉRISTIQUES TECHNIQUES

- **Motor unit** → stainless steel
- **Bowl** → stainless steel
- **Juicer basket** → stainless steel
- **Grating disc** → stainless steel
- **Ventilated electric motor** → constant speed (3400 rpm)
- **Throughput** → **220-260 lb/hour** of fruit or vegetables\* for the **J 80 Ultra**.  
**260-350 lb/hour** for the **J 100 Ultra**.

\* In optimum working conditions, i.e. a suitable worktop, ready prepared fruit and accessories (jug, bin, etc.) all within easy reach.

### • WEIGHT

	Net	Gross
J 80 Ultra	24 lbs	28.2 lbs
J 100 Ultra	28.4 lbs	34,4 lbs

### • DIMENSIONS (in inches)

#### J80 Ultra

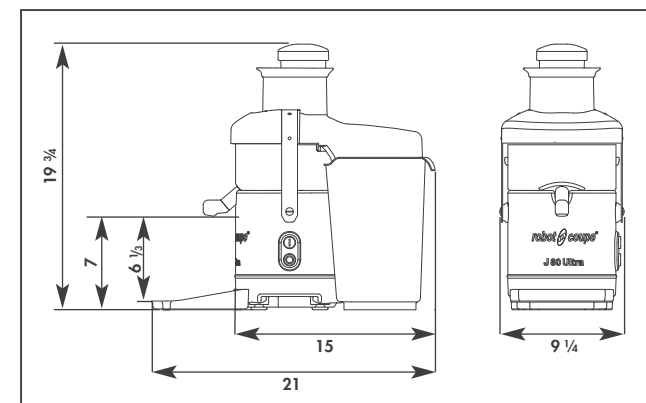

#### J 100 Ultra

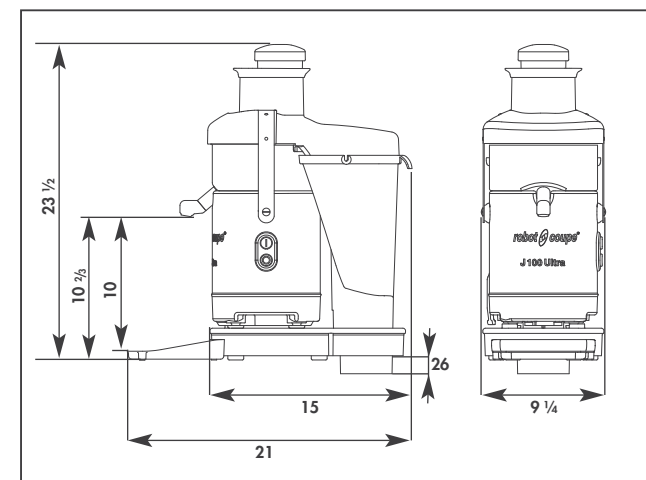

### • WORKING HEIGHT

We advise you to install your **J 80 Ultra/J 100 Ultra centrifugal juicer** on a flat and stable worktop at a suitable height.

### • NOISE LEVEL

The equivalent continuous sound level when the juicer is running empty is below 70 dB (A).

## • ELECTRICAL DATA

### J 80 Ultra

Motor	Speed (rpm)	Power (Watts)	Intensity (Amp.)
120V / 60Hz	3450	700	9

### J 100 Ultra

Motor	Speed (rpm)	Power (Watts)	Intensity (Amp.)
120V / 60Hz	3400	850	9

## SAFETY

- **The J 80 Ultra/J 100 Ultra juicer** will not start unless **the lid** has been correctly positioned and the safety arm properly locked into place. The motor will switch itself off as soon as you open the safety arm or press the Off button (red button).
- **The J 80 Ultra/J 100 Ultra juicer** is equipped with a powerful electric brake which will shut the machine down in less than 2 seconds if you open the safety arm while the juicer is running.
- To switch your juicer back on, simply fold the safety arm back over **the lid** and press the On button (green button).
- **The J 100 Ultra** is fitted with a thermal protection system which automatically switches the motor off if it remains overloaded for any length of time. If this happens, wait for the appliance to cool down before resetting **the thermal protection** (button on underside of the appliance).

- **WARNING:** never use the appliance without either the pulp container or the continuous ejection chute (for the **J 100 Ultra**).
- Always switch the machine off before removing the pulp container or the continuous pulp ejection chute (for the **J 100 Ultra**).
- Never insert your hand or any object other than the pusher into the ejector if the machine is plugged in or the basket is rotating.
- Never unplug the appliance by tugging on the power cord or with damp hands.



## REMEMBER

- **Never try to override the locking or safety systems.**
- **Never introduce anything other than fruit or vegetables into the feed tube.**
- **The lid of your appliance features a unique patented Auto Feed system. Simply introduce the food into the feed tube and let the machine do the rest.**
- **Should a blockage occur inside the feed tube, NEVER USE any object other than the pusher to clear it. Another solution is to switch the machine off and remove the food causing the problem inside the tube.**
- **Never use your hand to push the food down into the feed tube.**
- **Never insert your hand or any object other than the pusher into the ejector if the machine is running or the basket rotating.**



## TROUBLESHOOTING

SYMPTOMS	CAUSES AND/OR REMEDIES
The machine will not start	<ul style="list-style-type: none"> <li>- Check the fuses in your mains supply.</li> <li>- Close the safety arm properly</li> </ul> <b>J 100 Ultra :</b> <ul style="list-style-type: none"> <li>- Check that the thermal protection (button on underside) has been reset.</li> </ul>
Abnormal noise	<ul style="list-style-type: none"> <li>- The appliance has been incorrectly assembled. See "Assembly" chapter.</li> <li>- One of the parts is faulty and needs replacing.</li> </ul>
Inefficient grating	<ul style="list-style-type: none"> <li>- The grating disc is worn. Replace the grating disc inside the basket.</li> <li>- There is a blockage in the feed tube which needs to be cleared.</li> </ul>
The appliance vibrates	<ul style="list-style-type: none"> <li>- The pulp container is full or the basket is out of balance due to an accumulation of pulp on the filter.</li> <li>- If the vibration is permanent, check that the basket has not been damaged in some way.</li> </ul>
The basket does not stop immediately when the safety arm is opened. It takes more than 2 seconds to stop.	<ul style="list-style-type: none"> <li>- Have the appliance checked by a qualified person.</li> </ul>

**IMPORTANT :** For all repairs and maintenance, it is vital to use parts supplied by Robot-Coupe.

## SERVICE

See warranty first then;

Should your unit requires service, check with your dealer/distributor to know where local service is available. If not or if you wish your unit to be serviced at the factory, call for return instructions and ship the unit prepaid to our factory address.

PH : 1-800-824-1646

Robot-Coupe USA, Inc

Service Department Repair

264 South Perkins Street

Ridgeland, MS 39157

For service in Canada contact the Robot-Coupe USA factory for repair instructions.

## RECIPES

*Fruit and vegetables can be combined in an infinite number of ways to create exciting, colourful and totally natural drinks. Give your imagination free rein - bearing in mind these few golden rules for making cocktails:*

- *Always use untreated fruit.*
- *Using a shaker will make an opaque mixture more homogeneous.*
- *Fill the lower half of the shaker half-full with ice cubes. Avoid shaking your cocktail for too long, otherwise the ice will melt and spoil it.*

*Here is a selection of cocktail recipes, each for approximately four people.*

### PEACH SPARKLE

**Ingredients** (serves 3):

- 6 peaches
- ½ lemon
- 1 generous pinch ground nutmeg
- 10 fl oz soda water
- 1 thin slice fresh ginger

**Preparation:** stone the peaches and peel the lemon. There is no need to peel the ginger. Process the peaches in your J80 Ultra/J100 Ultra juicer first, followed by the ginger, then the lemon.

Next, combine the ground nutmeg and soda water with the juice. Divide between three glasses.

**Garnish:** *decorate the glasses with thin slices of peach.*

**Idea:** *you can use either white or yellow peaches for this juice.*

## HONEYED WATERMELON

**Ingredients** (serves 3):

- 26 oz watermelon
- ½ lemon
- 1½ tbsp honey
- 1½ tbsp water

**Preparation:** boil the honey and water together and allow to cool. Remove the watermelon rind and pips and cut the flesh into large chunks. Peel the lemon.

Process the fruit in your J80 Ultra/J100 Ultra juicer.

Pour the honey mixture into the glasses first, followed by the watermelon juice.

**Garnish:** *serve with thinly sliced watermelon.*

### CARROT CAPRICE

**Ingredients** (serves 4):

- 4 carrots
- 4 oranges
- 1 thin slice fresh ginger
- Ice cubes

**Preparation:** wash and scrub the carrots (no need to peel them). Peel the oranges. Process all the ingredients except for the ice cubes in your J80 Ultra/J100 Ultra juicer.

Divide between four glasses, add the ice cubes and serve immediately.

**Garnish:** *: decorate with an olive and a slice of orange.*

## CUCUMBER QUENCHER

### Ingredients (serves 4):

- 1 cucumber
- 4 Granny Smith apples
- 3 tbsp dill
- ½ lemon
- Goat's milk

**Preparation:** wash the cucumber but do not peel it, as the skin contains vitamins and will also lend color to your cocktail. For this reason, use an organic cucumber, if possible. Peel the lemon.

Process the cucumber, apples and dill in your J80 Ultra/J100 Ultra juicer, followed by the lemon. Combine the goat's milk with the juice.

**Garnish:** : decorate with radishes sliced in your Robot-Coupe veg prep machine (0.04" slicer disc).

## PRETTY PINK

### Ingredients (serves 4):

- 310 oz strawberries
- 3 carrots
- ¼ pineapple

**Preparation:** peel the pineapple and cut into chunks. You do not need to hull the strawberries, as their stalks will automatically be ejected into the pulp container.

Process the pineapple, strawberries and carrots in your J80 Ultra/J100 Ultra juicer in that order. Stir well and divide between glasses decorated with sliced strawberries.

**Idea:** liven up your cocktail with a pinch of ground vanilla bean, cardamom or ginger.

## APPLE-KIWI

### Ingredients (serves 3):

- 3 Granny Smith apples
- ½ lime
- 3 kiwi fruit

**Preparation:** peel the lime. Peel the kiwis so that the cocktail retains a good green color. Process all the ingredients in your J80 Ultra/J100 Ultra juicer.

Stir with a spoon and serve immediately, before the apple starts to go brown

**Idea:** if you find the taste too acidic, simply add a little honey or cane sugar syrup. You can also replace the kiwi fruit with a cucumber or a stick of celery

## MELLOW GRAPEFRUIT

### Ingredients (serves 3):

- 9 oz orange
- 9 oz grapefruit
- 9 oz strawberries

**Preparation:** peel the oranges and grapefruit to avoid a bitter taste. Process all the ingredients in your J80 Ultra/J100 Ultra juicer.

Stir well and divide between the glasses.

**Idea:** if you find the juice too acidic, simply add a little honey or cane syrup.

## ORIENTAL

### Ingredients (serves 3):

- ½ pineapple
- 3 oranges
- 1 tsp vanilla extract

**Preparation:** peel the fruit. Process the pineapple in your J80 Ultra/J100 Ultra juicer first, followed by the oranges.

Stir the vanilla extract into the juice and serve in small shot glasses.

**Idea:** replace the oranges with coconut milk.

## CLASSIC

### Ingredients (serves 3):

- 4 carrots
- 3 apples
- 1 lemon

**Preparation:** peel the lemon. Wash and scrub the carrots (no need to peel them). Process all the ingredients in your J80 Ultra/J100 Ultra juicer.

Stir well and serve.

**Idea:** you can substitute pears for the apples.

## GAZPACHO

### Ingredients (serves 3):

- 18 oz ripe tomatoes
- ½ small red pepper
- ½ cucumber
- ½ small stick celery
- 1 tbsp olive oil
- Drop of sherry vinegar
- Salt
- Pepper

**Preparation:** process all the vegetables in your J80 Ultra/J100 Ultra juicer, then add the olive oil, sherry vinegar and salt.

**Garnish:** decorate with a twist of lemon peel and a slice of tomato.

**Idea:** as tomato opens the appetite, serve the gazpacho at the start of the meal.

## MELON MELODY

### **Ingredients** (serves 3):

- 14 oz green-skinned melon
- 1 Granny Smith apple
- ½ lemon

**Preparation:** remove the melon rind and pips and cut the flesh into large chunks. Peel the lemon. Process all the ingredients in your J80 Ultra/J100 Ultra juicer.

Stir with a spoon and serve immediately, flavored with a few mint leaves.

**Garnish:** Garnish: decorate with melon diced in your Robot-Coupe veg prep machine (0.2 x 0.2 x 0.2" dicing attachment).

**Idea:** replace the melon with watermelon.

## MELON-PEAR WITH TURMERIC

### **Ingredients** (serves 4):

- 3 lb yellow honeydew melon
- 1 grapefruit
- ½ pear
- ½ Golden Delicious apple
- 1 thin slice fresh ginger
- ½ lemon grass stalk
- 1 tiny pinch turmeric

**Preparation:** peel the melon and grapefruit. Process the apple, ginger, lemon grass, pear, melon and grapefruit in your J80 Ultra/J100 Ultra juicer in that order. Stir well and divide between four glasses.

**Garnish:** decorate the glasses with pear sliced in your Robot-Coupe veg prep machine (0.04" slicer disc).

## APPLE-CELERY

### **Ingredients** (serves 4):

- 4 Granny Smith apples
- 2 sticks celery
- 1 thin slice fresh ginger
- ½ lemon
- Salt

**Preparation:** wash the celery sticks thoroughly and process in your J80 Ultra/J100 Ultra juice, followed by the ginger, then the apples. Season with a little salt and serve immediately, before the apple starts to go brown.

**Garnish:** decorate the glasses with apple sliced in your Robot-Coupe veg prep machine (0.04" slicer disc).

**Idea:** you can use pears instead of apples.

## ASPARAGUS SPEARS

### **Ingredients** (serves 3):

- 2.2 lb green asparagus
- 1 pinch ground Espelette pepper
- 1 pinch fleur de sel sea salt

**Preparation:** peel the asparagus spears and discard the tough ends of the stalks.

Process in your J80 Ultra/J100 Ultra juicer.

Season with a little Espelette pepper and sea salt.

**Idea:** use this cocktail to accompany a salmon dish.

## SCARLET COCKTAIL

### **Ingredients** (serves 4):

- 1 cooked beetroot
- 2 carrots
- 2 small bunches red grapes
- 2 Granny Smith apples
- Cayenne pepper

**Preparation:** process all the fruit and vegetables in your J80 Ultra/J100 Ultra juicer.

Season the juice with Cayenne pepper and serve chilled.

**Garnish:** decorate each glass with a slice of baby beetroot.



**robotcoupe®** U.S.A., Inc.

**J 80 Ultra**  
Serial number 521xxxxx03

1 Speed, 120 Volt, 1 Phase  
60Hz, 1 HP, 3450 RPM, 9 Amps

ETL LISTED 9900098  
Conforms to  
UL NSF/ANSI  
Std 763 Std 8  
Certified to  
CAN/CSA  
Std C22.2 No.195

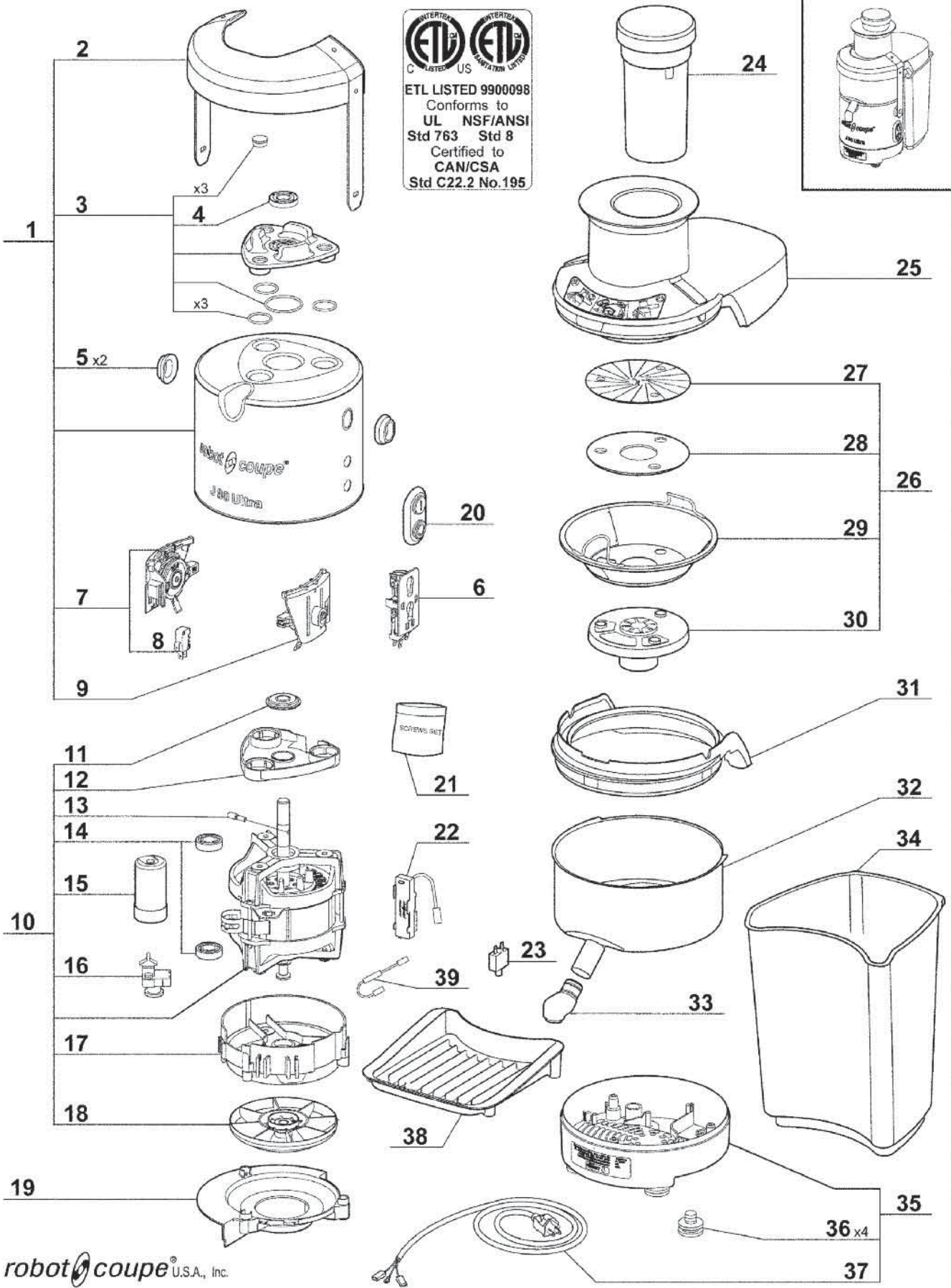

**robotcoupe®** U.S.A., Inc.

PH: 1-800-824-1646 FAX: 601-888-9134  
email: info@robotcoupeusa.com

Index	Pièce / Part	Description
1	39 982	MOTOR SUPPORT ASSEMBLY
2	39 896	LOCKING LEVER
3	39 897	BOWL CENTRING
4	501 010S	SHAFT SEAL
5	39 898	BEARING CACHE (Qty = 2)
6	39 899	ON/OFF BLOCK ASSEMBLY
7	39 900	LEFT BEARING ASSEMBLY
8	507 007S	SWITCH
9	39 901	RIGHT BEARING ASSEMBLY
10	39 924	MOTOR
11	39 902	SHAFT DEFLECTOR
12	39 903	MOTOR CENTRING
13	39 904	MOTOR SHAFT PIN
14	39 905	BALL BEARINGS KIT
15	600 089S	CAPACITOR
16	500 296S	MOTOR STARTING RELAY
17	39 906	BAFFLE
18	118 512S	MOTOR FAN
19	39 907	MOTOR DEFLECTOR
20	39 927	CONTROL PANEL ASSEMBLY
21	39 960	SCREWS SET (including all screws for the motor base)
22	39 894	BRAKING MODULE
23	39 590	CIRCUIT BREAKER
24	39 908	PUSHER
25	39 909	LID
26	39 910	BASKET ASSEMBLY
27	39 911	GRATER
28	39 929	ANGLED SPACER
29	39 912	SIEVE
30	39 913	HUB
31	39 914	BOWL FLANGE
32	39 915	BOWL
33	39 916	SPOUT
34	39 917	PULP COLLECTOR
35	39 983	BASE ASSEMBLY
36	39 928	FEET (Qty = 4)
37	39 890	POWER CORD
38	39 516	DRIP TRAY
39	39 587	RESISTOR

**robotcoupe®** U.S.A., Inc.

**J 100 Ultra**  
Serial number 603xxxxx03

1 Speed, 120 Volt, 1 Phase  
60Hz, 1.2 HP, 3400 RPM, 9 Amps

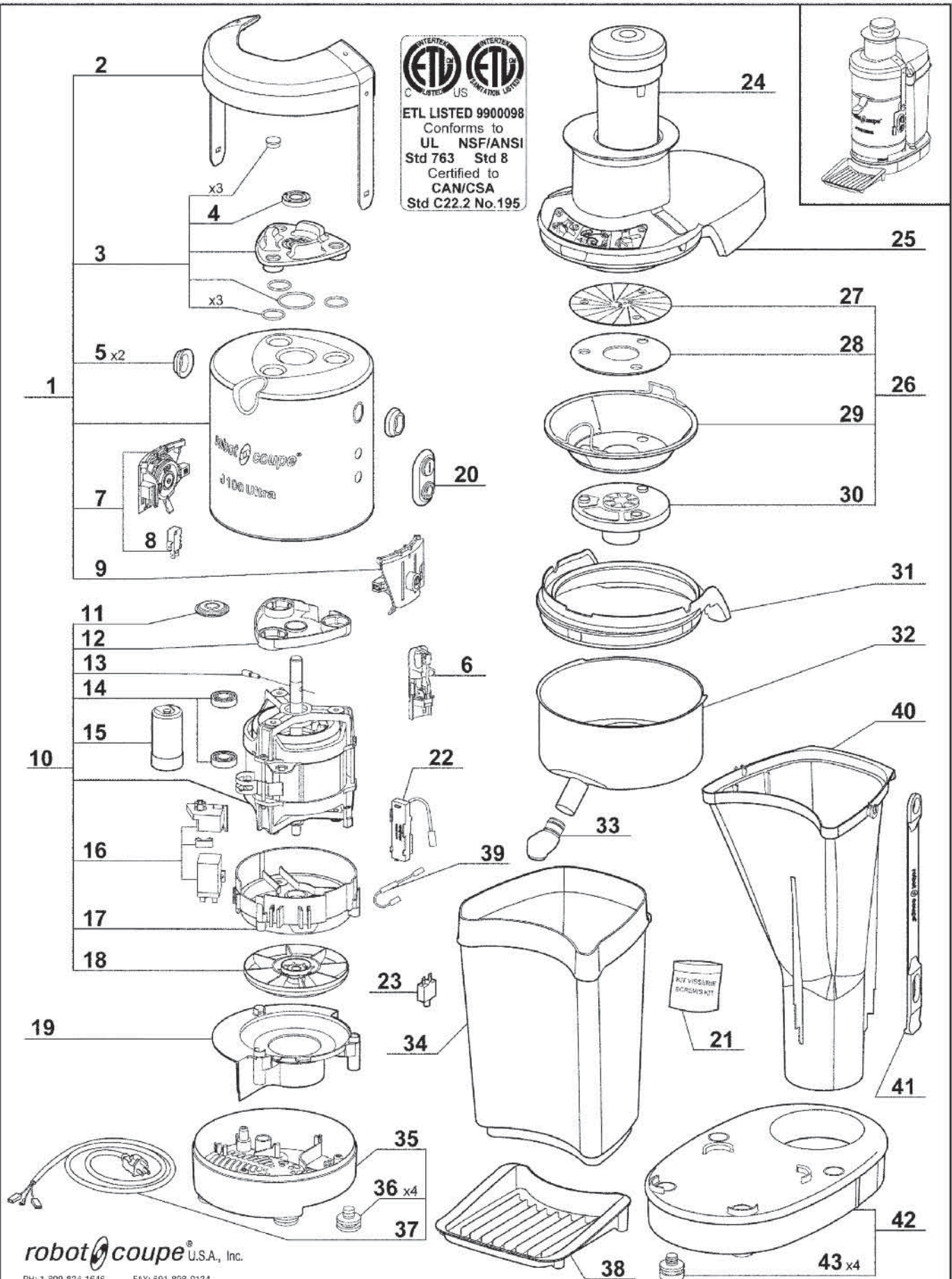

**robotcoupe®** U.S.A., Inc.

PH: 1-800-824-1646 FAX: 601-888-9134  
email: info@robotcoupeusa.com

Index	Pièce / Part	Description
1	39 512	MOTOR SUPPORT ASSEMBLY
2	39 896	LOCKING LEVER
3	39 897	BOWL CENTRING
4	501 010S	SHAFT SEAL
5	39 898	BEARING CACHE (Qty = 2)
6	39 899	ON/OFF BLOCK ASSEMBLY
7	39 900	LEFT BEARING ASSEMBLY
8	507 007S	SWITCH
9	39 901	RIGHT BEARING ASSEMBLY
10	39 524	MOTOR
11	39 902	SHAFT DEFLECTOR
12	39 903	MOTOR CENTRING
13	39 904	MOTOR SHAFT PIN
14	39 905	BALL BEARINGS KIT
15	600 089S	CAPACITOR
16	39 588	MOTOR STARTING RELAY
17	39 906	BAFFLE
18	118 512S	MOTOR FAN
19	39 509	MOTOR DEFLECTOR
20	39 927	CONTROL PANEL ASSEMBLY
21	39 514	SCREWS KIT (including all screws for the motor base)
22	39 894	BRAKING MODULE
23	39 590	CIRCUIT BREAKER
24	39 908	PUSHER
25	39 909	LID
26	39 910	BASKET ASSEMBLY
27	39 911	GRATER
28	39 929	ANGLED SPACER
29	39 912	SIEVE
30	39 913	HUB
31	39 914	BOWL FLANGE
32	39 915	BOWL
33	39 916	SPOUT
34	39 513	PULP COLLECTOR
35	39 983	BASE ASSEMBLY
36	39 928	FEET (Qty = 4)
37	39 890	POWER CORD
38	39 516	DRIP TRAY
39	39 587	RESISTOR
40	39 522	CONTINUOUS PULP EJECTION
41	39 510	STRAP
42	39 515	MACHINE BASE
43	39 833	MACHINE BASE FEET (Qty = 4)

Serial # : from 52101591 03 D - 07

	English	Espanol	Français
CD	Starting capacitor	Condensador d'arranque	Condensateur de démarrage
DT	Circuit breaker 12 A	Disyuntor 12 A	Coupe-circuit 12 A
EA	Starting phase	Fase auxiliar	Phase auxiliaire
EP	Main phase	Fase principal	Phase principale
KD	Starting relay	Rele d'arranque	Relais de démarrage
MA	ON / OFF switch	Interruptor MARCHA / PARADA	Interrupteur MARCHÉ / ARRÊT
MF	Breaking module	Modulo de frenaje	Module de freinage
MO	Single phase Motor	Motor monofasico	Moteur monophasé
PTO	Motor thermal protector	Protector termico del motor	Protecteur thermique du moteur
R	Resistor 1 Ohm 6 W	Resistencia 1 Ohm 6 W	Résistance 1 Ohm 6 W
SW	Clamp safety switch	Interruptor de seguridad con collar	Interrupteur sécurité étrier

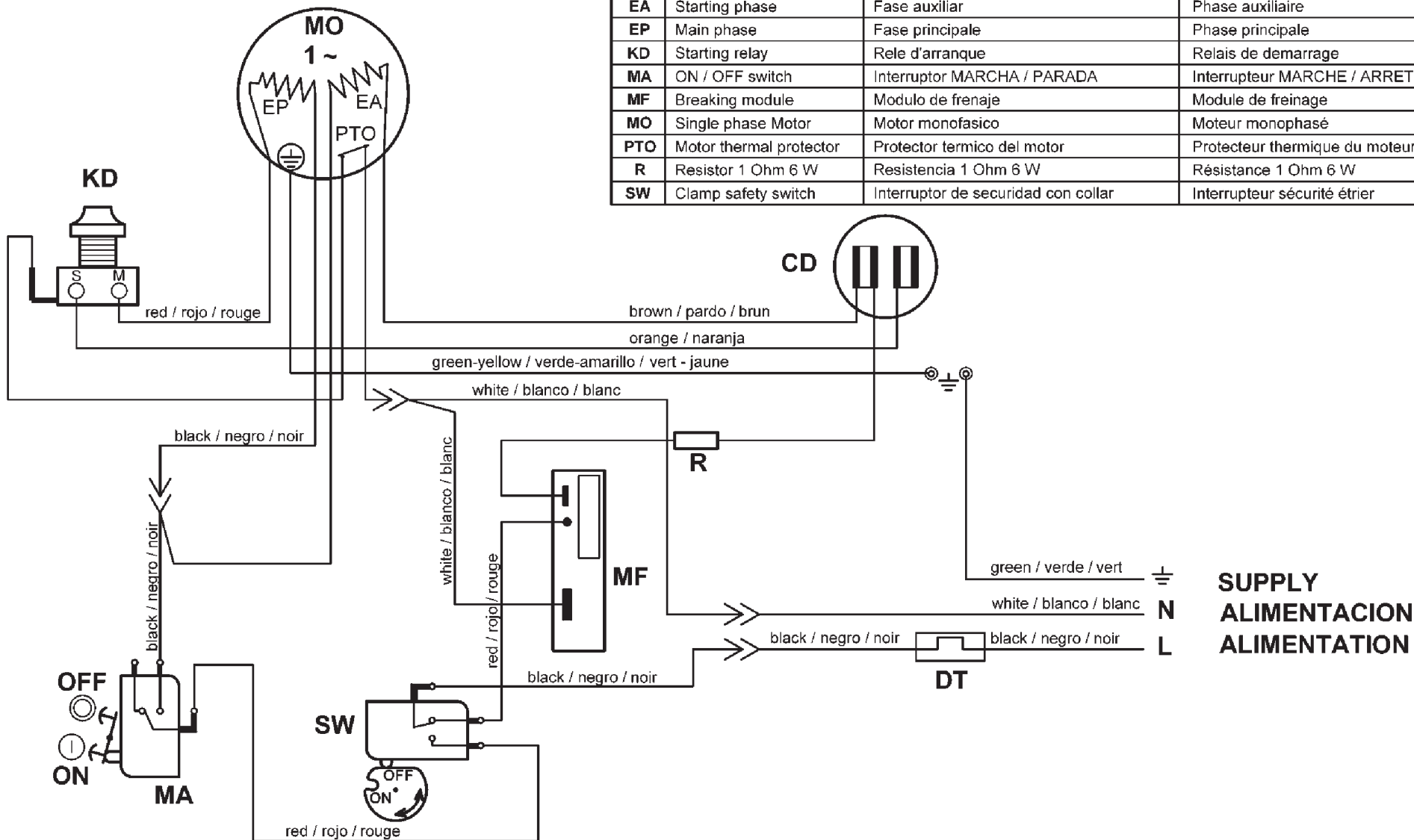

**SUPPLY**  
**ALIMENTACION**  
**ALIMENTATION**

ELECTRIC DIAGRAM

**J 100 Ultra**

120V/60Hz Single phase

ESQUEMA CONEXIONES

SCHEMA ELECTRIQUE

Serial # : from 603XXXXX 03 D - 11

	English	Espanol	Français
CD	Starting capacitor	Condensador d'arranque	Condensateur de démarrage
DT	Circuit breaker 12 A	Disyuntor 12 A	Coupe-circuit 12 A
EA	Starting phase	Fase auxiliar	Phase auxiliaire
EP	Main phase	Fase principal	Phase principale
KD	Starting relay	Rele d'arranque	Relais de démarrage
MA	ON / OFF switch	Interruptor MARCHA / PARADA	Interrupteur MARCHÉ / ARRÊT
MF	Breaking module	Módulo de frenado	Module de freinage
MO	Single phase Motor	Motor monofasico	Moteur monophasé
PTO	Motor thermal protector	Protector termico del motor	Protecteur thermique du moteur
R	Resistor 1 Ohm 6 w	Resistencia 1 ohmio 6 w	Résistance 1 Ohm 6 w
SW	Lid safety switch	Interruptor de seguridad cojinet	Interrupteur sécurité couvercle

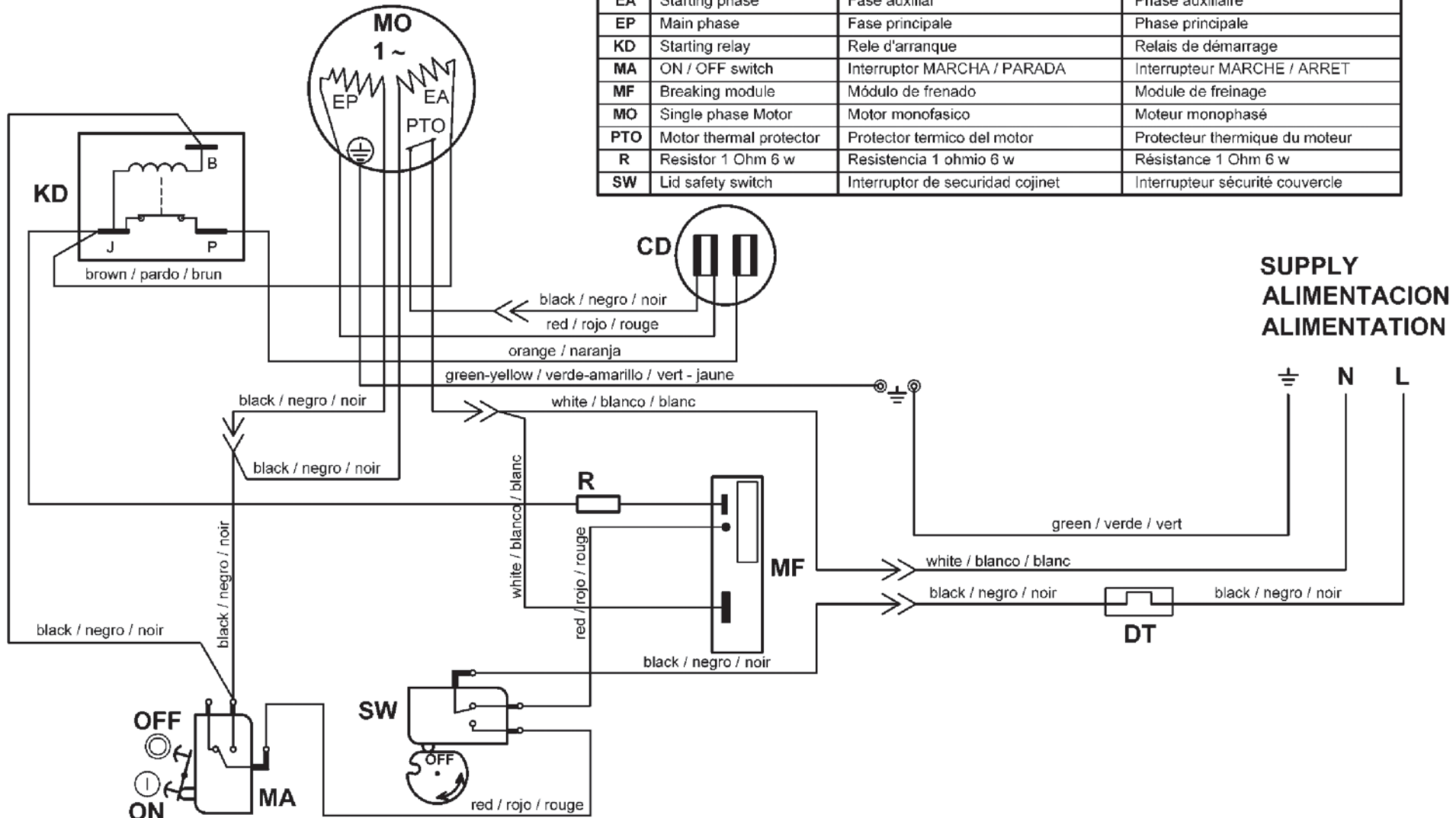

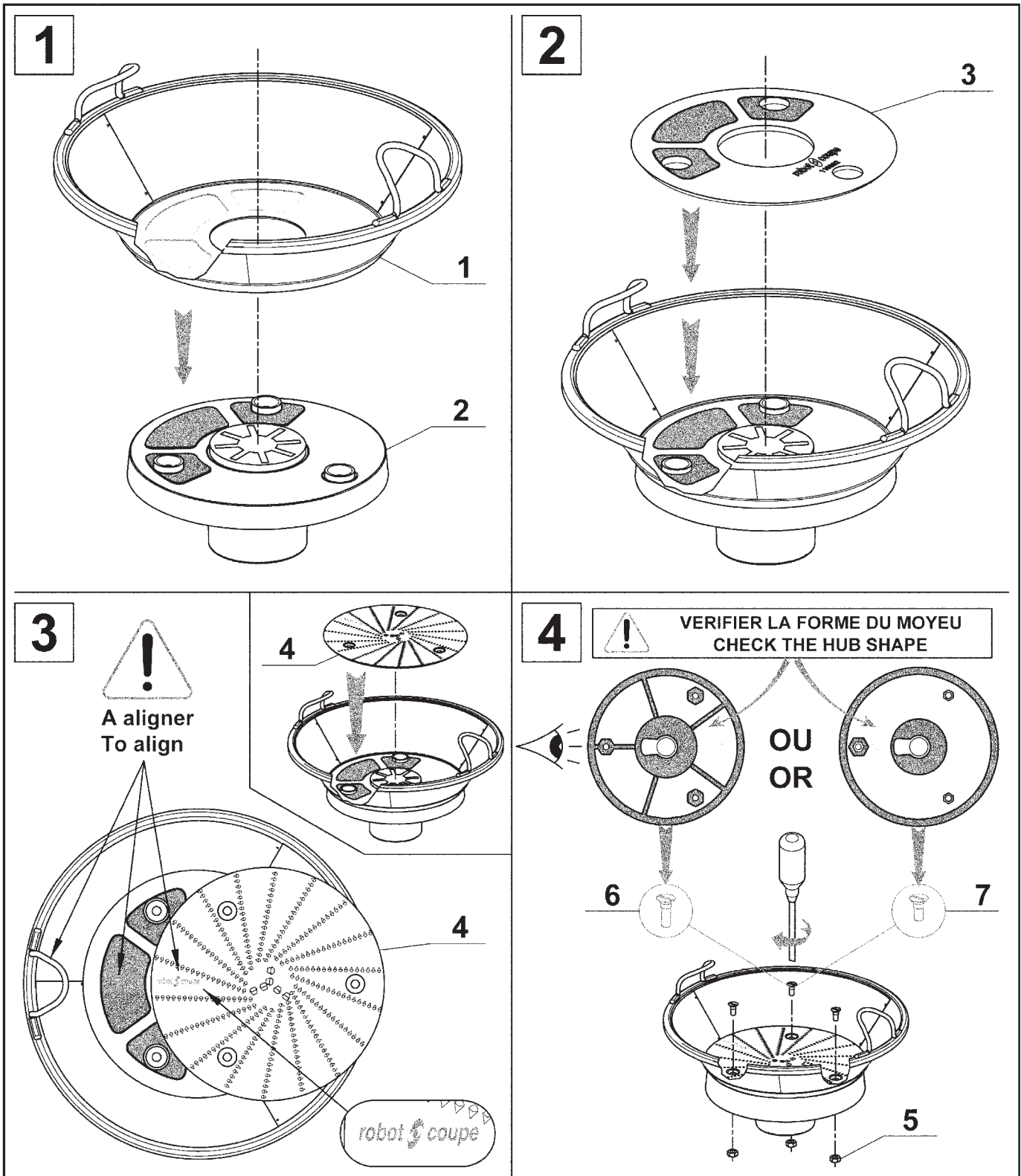

Index	Pièce / Part	Désignation	Description	Quantité / Quantity
1	39 912	FILTRE	SIEVE	1
2	39 913	MOYEU	HUB	1
3	39 929	RONDELLE INCLINEE	ANGLED SPACER	1
4	39 911	DISQUE RAPEUR	GRATER	1
5	206 162	ECROU HM4 INOX	NUT HM4 (Stainless Steel)	3
6	200 123	VIS F M4x12 INOX	SCREW M4x12 (Stainless Steel)	3
7	206 972	VIS F M4x10 INOX	SCREW M4x10 (Stainless Steel)	3



***robot coupe***<sup>®</sup>

**Robot-coupe USA. Inc.**

P.O. Box 16625, Jackson, MS 39236-6625

264 South Perkins St., Ridgeland, MS 39157

e-mail: [info@robotcoupeusa.com](mailto:info@robotcoupeusa.com)

website: [www.robotcoupeusa.com](http://www.robotcoupeusa.com)

Phone : 1-800-824-1646