

**OPERATION MANUAL
FOR**

Robot  Coupe[®]

MODEL

R4X and R6X

Series D

Series D Serial Numbers

R4X- 233xxxxx03

R6X- 237xxxxx03

robot coupe U.S.A., Inc.
P.O. Box 16625, Jackson, MS 39236-6625
280 South Perkins St., Ridgeland, MS 39157
email: robocoup@misnet.com
website: www.robotcoupeusa.com
1-800-824-1646

Series-D Plates

IMPORTANT NOTICE: Use this chart only if a "Series-D" mark is displayed on your machine.

Size	Slicing Plates	Replacement Blades (1 Per Plate)
4mm.....	C477SA.....	C449SBA
5mm.....	C437SA.....	C449SBA
8mm.....	C436SA.....	C449SBA
10mm.....	C435SA.....	C449SBA
14mm.....	C434SA.....	C449SBA
19mm.....	C422SA.....	C449SBA

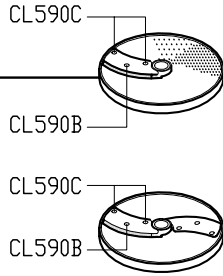

Size	Slicing Plates	Replacement Blades (2 Per Plate)
1mm.....	C444SA.....	C449SBA
2mm.....	C445SA.....	C449SBA
3mm.....	C446SA.....	C449SBA

Size	Waved Slicing Plate	Replacement Blades (1 per Plate)
5mm.....	C464W.....	29786

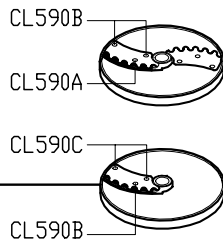

Size	Waved Slicing Plates	Replacement Blades (2 Per Plate)
2mm.....	C445W.....	29786
3mm.....	C446W.....	29786

Size	Cabbage Grating Plate	Replacement Grids (1 Per Plate)
4mm.....	28136.....	*

* Number not Available at printing.

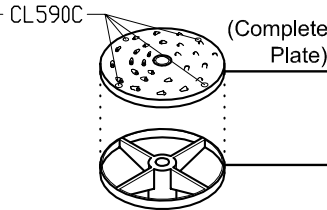
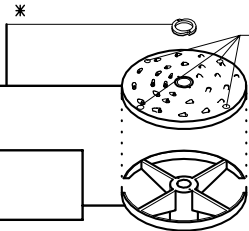

Size	Grating Plates	Replacement Grids (1 Per Plate)
EX Fine.....	C495GPA.....	C402GN
Hard Cheese...	C452GPA.....	C456GN
1.5mm.....	C494GPA.....	C404GN
2mm.....	C451GPA.....	C455GN
3mm.....	C450GPA.....	C454GN
4mm.....	C475GPA.....	C475.1GN
5mm.....	C453GPA.....	C457GN
7mm.....	C478GPA.....	C418GN
9mm.....	C433GPA.....	C458GN

Cabbage Grating Plate Base.....	*
---------------------------------	---

Grating Plate Base.....	C459BA
-------------------------	--------

Size	Julienne Plates	Replacement Blades	
		Vertical	Horizontal
2x2mm.....	C460JA.....	C461JBA.....	C440JBA
4x4mm.....	C462JA.....	C463JBA.....	C440JBA
6x6mm.....	C438JA.....	C439JBA.....	C440JBA
8x8mm.....	C466JA.....	C467JBA.....	C440JBA
2x4mm.....	C483JA.....	C4831JBA.....	C440JBA
2x6mm.....	C484JA.....	C4841JBA.....	C440JBA
2x8mm.....	C486JA.....	C4861JBA.....	C440JBA

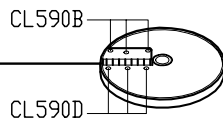

Size	French Fry Kit			
	Plate Only	Blade Only	Grid Only	
8x8mm.....	28134.....	29267.....	29564.....	118395
10x10mm.....	28135.....	29276.....	29564.....	108396

Size	Dicing Kit	Plate Only	Blade Only	Dicing Grid Only
5x5mm.....	28110.....	28128.....	29780.....	28117
8x8mm.....	28111.....	28129.....	29780.....	28118
10x10mm.....	28112.....	28130.....	29780.....	28119
14x14mm.....	28113.....	28131.....	29780.....	28120
20x20mm.....	28114.....	28132.....	29780.....	28121
25x25mm.....	28115.....	28133.....	29780.....	28122

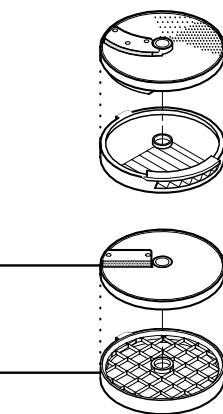

Phone: 1-800-824-1646
 Fax: 601-898-9134
 email: robocoup@misnet.com



INTRODUCTION

The Robot Coupe commercial food processor performs a host of culinary feats. It is designed for high speed and quality vegetable processing. The models R4X and R6X will slice, julienne, shred, grate and also cut French fries and dice many products with the continuous feed attachment.

This operators manual is broken down into sections giving you detailed instructions for assembly and operation of the continuous feed attachment and the cutter bowl attachment. Close attention should be paid to all instructions in this manual to ensure a long life utilization of your food processor.

This manual should be kept within easy access to all users for reference, and should be read completely by all first time users of the machine.

Maintaining the food processor in good working condition is one of the most important measures to be taken. Inspect the machine and all parts regularly to make sure they are in good working condition.

DO NOT operate a machine that has malfunctioned in any way.

Discard any food processed at the time of a malfunction and have the machine inspected and repaired at one of the Robot Coupe Authorized Service Agencies, a list is provided in the back of this manual. Contact one of these service agencies for all of your service, parts, and accessory requirements.

CAUTION: Your Robot Coupe comes with sharp cutting plates. Always handle with safety in mind. We suggest that a pair of cut-resistant gloves be worn when handling the cutting plates.

Machine Specifications:

The Models R4X and R6X are equipped with a high speed motor generating 1 Hp which plugs into a standard 120 volt/ 60 Hz, 15 amp power outlet. The full load amperage rating for the R4X is 7.5 amps, and the amperage rating for the R6X is 7.6 amps. The standard machines are supplied with a continuous feed attachment, and two cutting plates. The machines are equipped with push type on and off buttons. The R6X has a metal feed lead with a hinged pusher and the R4X has a plastic feed lead.

- I. INTRODUCTION
- II. ASSEMBLY/DISASSEMBLY INSTRUCTIONS
- III. OPERATING INSTRUCTIONS
- IV. PREVENTIVE MAINTENANCE GUIDE
- V. TROUBLE SHOOTING AIDS
- VI. SERVICE AGENCY LISTING

II. ASSEMBLY/DISASSEMBLY INSTRUCTIONS

Your Robot Coupe should be placed on a sturdy work surface at a comfortable working height and have a standard 115 volt power outlet available. Always keep the machine unplugged during assembly and disassembly.

A. ASSEMBLY INSTRUCTIONS

Illustration #1

Become familiar with the part names as you assemble the unit.

Always use caution and wear cut-resistant gloves when handling the blade or the cutting plates.

Always unplug the machine during assembly and disassembly.

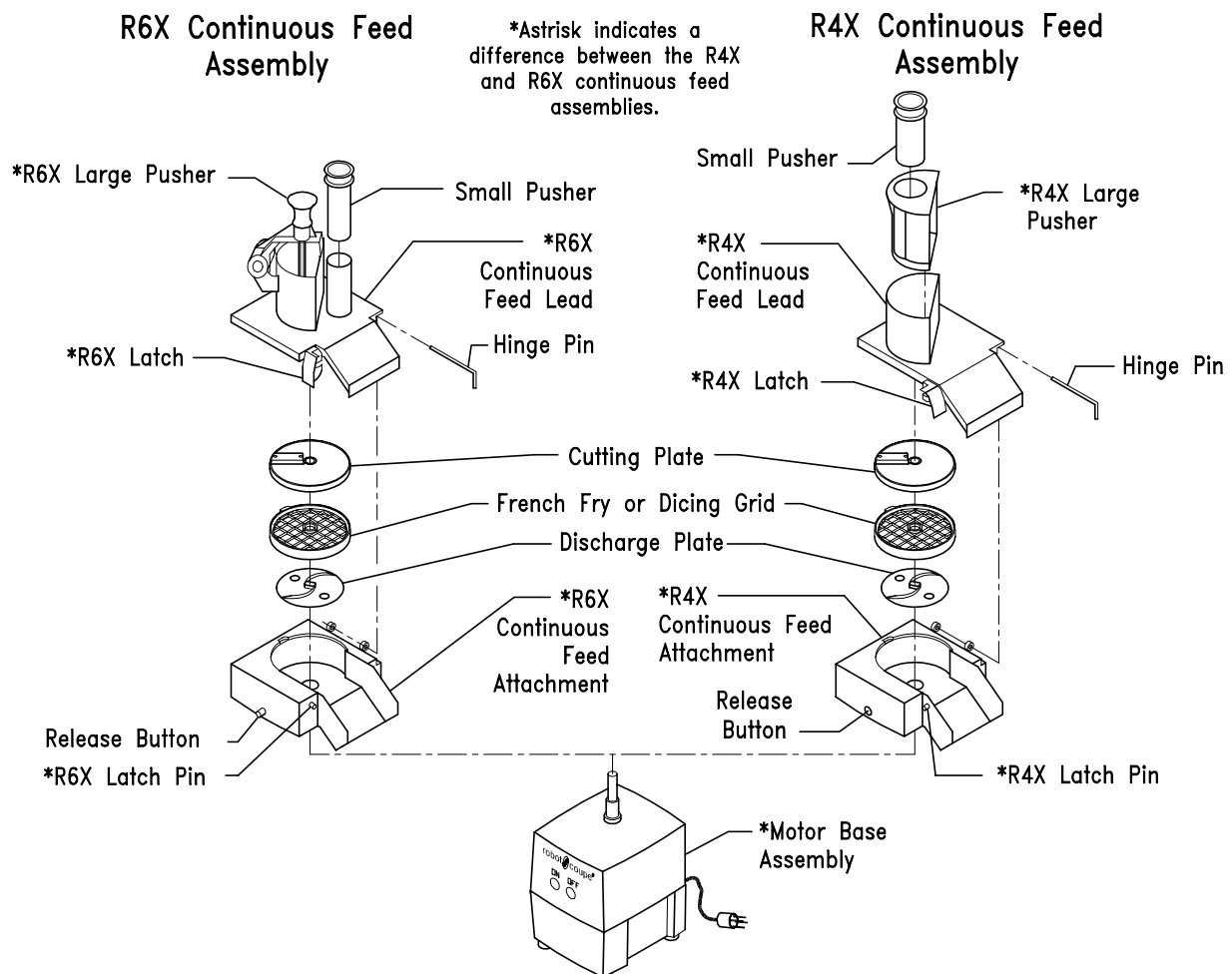

ASSEMBLY INSTRUCTIONS

1 Place the motor base assembly at a comfortable height on a sturdy work surface. Remove the plastic discharge plate from inside the continuous feed attachment. Place the continuous feed attachment on the motor base with the release button at front center of the motor base assembly (see drawing). Rotate the attachment counterclockwise until it locks into place with a snap action. When the attachment is in the proper position, it should be level with the top surface of the motor base assembly. **NOTE:** The machine will not operate correctly unless the continuous feed attachment is fully seated and secured in place.

2 Place the discharge plate on the motor shaft with the appropriate side up. Use the side with the small straight fins for all julienne cuts or other delicate cuts. The large finned side may be used for dicing or shredding. The product will not exit the machine without the discharge plate.

Warning: The plates are sharp. Always use caution and we suggest that a pair of cut-resistant gloves be worn when handling the plates and grids.

3 IF YOU ARE PREPARING TO SLICE, GRATE, OR JULIENNE: Place the plate of your choice on the motor shaft and turn it clockwise until it drops into place and is fully seated. The top of the plate should be just above the surface of the continuous feed attachment. Proceed to step 5.

4 IF YOU ARE PREPARING TO USE A DICING OR FRENCH FRY KIT:

NOTE: The recessed rim on the continuous feed attachment must be free from product and clean so the grid can be firmly seated. **The discharge plate must be in the machine or the product will not exit.**

With the tab on the plastic grid aligned with the cutout in the Continuous Feed Attachment, place the plastic grid onto the recessed rim of the continuous feed attachment. Put the slicing plate on top of the dicing grid with the stem of the plate DOWN. Rotate the plate until the cutout in the stem drops into place on the motor shaft pin. Continue rotating the plate a full turn. If rubbing occurs, **DO NOT PROCEED**—call your service agency. The rim on the plate when properly installed should be slightly above the surface of the continuous feed attachment.

5 Place the continuous feed lead on the continuous feed attachment and secure in place with the holding pin. The lead should fit flush on the continuous feed attachment. Close the lead and lock the latch.

6. Place the pushers in their corresponding openings in the continuous feed lead.

7. DO NOT OPERATE THE MACHINE UNLESS IT IS PROPERLY ASSEMBLED AND THE CONTINUOUS FEED LEAD IS FULLY SEATED AND CENTERED OVER THE ATTACHMENT!

Dicing Assembly

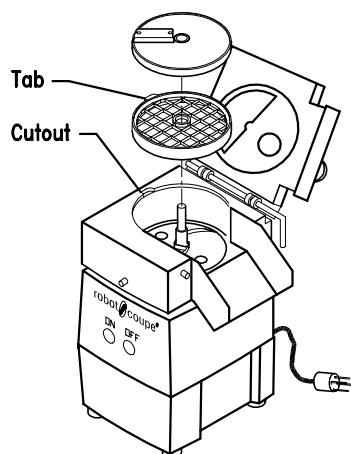

French Fry Assembly

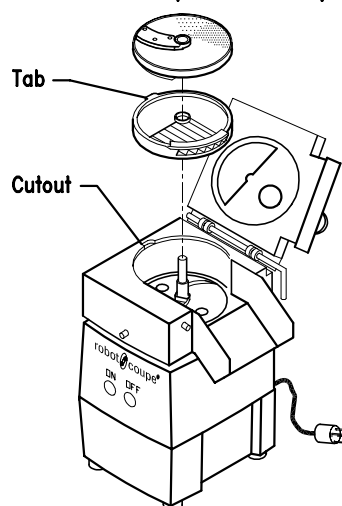

B. DISASSEMBLY OF THE CONTINUOUS FEED ATTACHMENT

- 1 Turn the unit OFF and UNPLUG it from the wall socket.**
- 2 Pull the plastic pushers out of the openings.**
- 3 Pull out hinge pin from continuous feed lead and lift up latch at upper right front of machine (see drawing). Remove the continuous feed lead.**
- 4 Remove cutting plate. Rotate plate slightly counterclockwise, then lift free of shaft. Remove dicing or French fry grid if any, then lift out the plastic discharge plate.**
- 5 Press the release button (see drawing) on the continuous feed attachment and at the same time turn the continuous feed attachment clockwise. The continuous feed attachment releases and can be lifted off over the motor shaft.**

Before continuing, you should completely read the instructions contained in the rest of this manual.

The continuous feed lead has two feed openings, one large and one small, with matching pushers. The food is inserted in the chosen opening by removing the pusher with one hand and then depositing the food into the chute with the other hand. The pusher should then be used to push the food through the opening.

III. OPERATING INSTRUCTIONS

THE UNIT SHOULD BE OFF EXCEPT WHEN PROCESSING IS UNDERWAY.

It is recommended that the machine be operated on a 50% duty cycle. This is easily accomplished since the preparation time (cleaning, coring, peeling, and loading) takes longer than the processing time. This will yield the longest life for your machine.

The Robot Coupe Food Processor will slice, grate, shred and julienne. These processes will be performed in a matter of seconds. Because of the speed of the process, it is necessary that the operator perform preliminary steps before turning the machine on. Food preparation, feed chute loading, and availability of a receptacle (catch pan) for receiving the finished product are some of the steps to assure positive control of the processing operation.

Food preparation will be required to assure that the produce will fit a feed chute opening. Additionally, according to personal preference, some products may or may not be cored or peeled. Feed chute selection should be made depending upon the product to be processed. As an example, good consistency of small round produce (carrots, cucumbers, etc.) necessitates use of the small feed chute to allow better operator control. Use of the larger port for this type of produce may result in an undesired finished product, e.g., slicing with the grain. In general, more control of the processing operation can also be obtained by filling the selected feed chute and placing the pusher in position before turning the machine on.

Adherence to certain operational techniques will also enhance the processing operation. For instance, a consistent pressure with the pusher upon the produce will yield a consistent output. Application of more pressure will increase the thickness of the product, e.g., thicker slice, while reduction in pressure will result in a finer product. However, do not apply enough pressure to stall or slow the motor. This will cause damage to both the plate and the motor. If no pressure is applied at all and the produce is permitted to bounce around, an inconsistent product may result. When the pusher has settled fully in the feed chute, press the off switch and re-load the entry port for a repeat process.

DO NOT remove the continuous feed lead when the motor is running. Wait until the motor has come to a full stop.

DO NOT attempt to run frozen products through the cutting plates.

DO NOT put anything other than food products in the feed chute.

Wear cut-resistant gloves when handling the cutting plates.

Keep hands out of the feed openings. Always use the food pushers.

(1) Slicing Operation: When preparing food to be sliced, make sure the food will fit into the proper feed chute. Produce such as carrots, cucumbers, etc., should be “squared” at both ends. This will provide a consistent slice throughout the whole product. With cabbage, lettuce or any product that has an undesirable core, the core should be removed. Medium size heads of lettuce or cabbage may be cut into thirds to fit in the feed chute. It is also suggested that the rounded half be squared to permit a consistent cut. The rounded portion can be dropped into the chute at the end and with no pressure applied, it will normally be processed uniformly. Larger heads of cabbage or lettuce may be more effectively processed if they are cut into fourths. When the preparation has been accomplished, fill the selected feed chute, place the pusher in position, turn the machine on and observe the results.

(2) Grating Operation: Again, prepare the product as to allow insertion into the feed chute. Consider which chute will be used. As an example, placement of carrots horizontally in the large chute will result in a long grated product, while vertical insertion in the smaller chute will result in a short grated product. It is recommended that chilled cheese be used when grated cheese is desired, otherwise a gumminess may result. A fine coating of cornstarch applied to the cheese before grating will aid in keeping the finished product separated. A fine coating of cornstarch will not be visible and is tasteless. Grating cheese is one of the most trying processes and may cause overheating of the motor if not done in the recommended manner. It is recommended that a slight pulsating pressure be applied with the pusher while grating, alternating slight pressure on the pusher—no pressure—continuing in this manner until the block of cheese is completely grated. It is recommended that the cheese be prepared to fit the opening in volumes which will permit motor cool-down time during long production runs.

(3) Julienne Operation: Insertion of the product to be cut must be horizontal if a long stick is to be achieved, e.g., squash sticks. Vertical insertion will result in finely chopped products, e.g., chopped celery. A finely chopped onion product may also be obtained with this operation.

DO NOT attempt to julienne meats or cheeses.

(4) Dicing Operation: The dicing operation requires that product be sliced both horizontally and vertically by the machine. The smaller the dice required, the more difficult the cut is to achieve. Soft or juicy produce will tend to mush if the dice is too small or the produce is too soft. Cheeses and meats represent the opposite extreme.

DO NOT ATTEMPT TO DICE MEATS OR CHEESES. Damage could occur to the blades and/or the motor and will not be covered under warranty. NOTE; You cannot julienne or dice meats or cheeses on any food processor.

During the dicing operation, attention should be given to the finished product. A visible change in the product will occur when the dicing grid requires cleaning. If this occurs remove the continuous feed lead and the slicing plate, then take a stiff bristle brush and force any product on the grid through.

PLATE UTILIZATION:**NEVER attempt to process frozen products!**

The standard machine comes with 2 plates (C446SA slicing and the C450GPA grating) at the time of printing. Check your most current price list for which plates are included as standard. User applications may require additional plates. The Robot Coupe processor will perform a variety of functions: slicing grating, dicing, and julienne. There are a total of 34 different plates available to perform these functions (see below).

8 slicing plates
8 grating plates
6 dicing plates
7 julienne plates
3 wave slicing plates
3 straight french fry plate combinations

The eight (8) slicing plates range from 1mm (approx. 1/64") to 14mm (approx. 1/2"):

Part Number	MM Slicing	Inches (Approx.)
C444SA	1mm	1/32"
C445SA	2mm	5/64"
C446SA	3mm	1/8"
C477SA	4mm	5/32"
C437SA	5mm	3/16"
C436SA	8mm	5/16"
C435SA	10mm	3/8"
C434SA	14mm	9/16"

The C444SA (1/32") slicing plate offers a very fine cut. A possible use for such a fine cut is the preparation of Japanese style vegetables. Typically these products (such as carrots or celery) will be placed in the pusher horizontally to obtain a long thin product.

The C445SA (5/64") slicing plate. Cabbage may be sliced with this plate for New York Style Cole Slaw. Carrots curls which adorn many dishes can be achieved with this slicer. The carrot slices should be dropped into cold water to permit curling. A nice carrot coin for salads can also be obtained.

The C446SA (1/8") slicing plate is ideal for salad bars i.e., cucumber slices, carrot "coins" (vertically sliced Carrots). Lettuce sliced by this plate is readily used with sandwiches, tacos, etc..

The C477SA (5/32") and C437SA (3/16") slicing plates are also ideal for salad bar use, for the stock pot where thicker cuts are desired. This blade is excellent also for orange or lemon slices as well as tomatoes, where a nice smooth surface is desired. NOTE: You can not slice meats or cheeses on any food processor.

The C434SA, C435SA, C436SA slicing plates are used in conjunction with the dicing grids. In addition thicker slices can be obtained for use in soups and stews. The C434SA (9/16") slicer also provides an excellent cut of lettuce for use in a salad.

There are eight grating plates available:

Part Number	Size MM	Inches (Approx.)
C495GPA	X-Fine	
C452GPA	Hard cheese	
C494GPA	1.5 mm	1/16"
C451GPA	2 mm	5/64"
C450GPA	3 mm	1/8"
C453GPA	5 mm	3/16"
C478GPA	7 mm	5/16"
C433GPA	9 mm	3/8"

The C452GPA hard cheese grating plate is designed specifically to grate Parmesan or Romano cheese. **CAUTION:** Softer cheese will tend to gum up the plate. The grated product is very fine. This plate can be used for making cracker or cookie crumbs. Dried bread crumbs can be obtained **CAUTION:** the moisture in fresh bread will cause clogging and poor results.

Use of either the C451GPA, C450GPA, or C453GPA, fine, medium, and course grating plates are much dependent upon personal choice and specific application. The medium and coarse grating plates offer a quality grated product with cheese, carrots, cabbage for cole slaw, etc..

There are seven Julienne plates available:

Part Number	Size MM	Inches (Approx.)
C460JA	2 x 2 mm	(5/64")
C483JA	2 x 4 mm	(5/64" x 5/32")
C484JA	2 x 6 mm	(5/64" x 1/4")
C486JA	2 x 8 mm	(5/64" x 5/16")
C462JA	4 x 4 mm	(5/32")
C438JA	6 x 6 mm	(1/4")
C466JA	8 x 8 mm	(5/16")

Products such as julienne carrots, chopped celery and finely chopped onions are obtainable as well as julienned celery roots. **DO NOT ATTEMPT TO JULIENNE MEATS OR CHEESES!**

A diced product requires two actions. First, a horizontal slice is made and then this slice is forced by the machine through the dicing grid to obtain a vertical cut. This results in a cubed product. The dimensions of this cube are varied via the selection of the slicing plate and dicing grid.

dicing grid	5x5 mm	8x8 mm	10x10 mm	14x14 mm	20x20 mm	25x25 mm
Plate						
5 mm	28110					
8 mm		28111				
10 mm			28112			
14 mm				28113		
20 mm					28114	
25 mm						28115

The shaded areas indicate additional combinations that can be used.

The 5mm dicing combination is generally used for potatoes and squash because of its small size.

The 8mm smaller dicing combinations can be used for finely diced carrots, celery, etc. and readily used in soups or stews. The larger (14 mm or greater) dicing combinations work well with fruits such as apples, pears, pineapple, etc.

When dicing tomatoes, green peppers, onions, or celery always insure that the product is introduced into the machine so that the slicing plate will be slicing across the grain of the vegetable.

CAUTION: The softer the produce, the less acceptable will be the finished product.

When dicing tomatoes, green peppers, onions, or celery always insure that the product is introduced into the machine so that the slicing plate will be slicing across the grain of the vegetable.

After a time of use, the dicing grid will require cleaning. A visible difference in the finished product will occur when cleaning is required. The best way to clean the grid is: remove the slicing plate, take a stiff bristle brush and force the product that is on the grid to go through.

There are three (3) wave slicing plates available:

Part Number	MM Slicing	Inches (Approx.)
C445W	2mm Waved	5/64"
C446W	3mm Waved	1/8"
C464W	5mm Waved	3/16"

The waved slicing plates work just like the straight slicing plates, except that the product has waved or ruffled sides. This can be an attractive alternative to the flat slices that are so prevalent on salad bars. By adding a waved plate, you can dramatically alter the presentation of the food. As with the straight slicing plates, remember that harder foods slice best when cut thinner and softer foods slice best when cut thicker.

While the standard Robot Coupe comes with two specific plates (C446SA and C450GPA) at time of printing, many user applications may require some of the optional plates available with the unit. Typically 5 - 7 plates will perform most of the functions called by any one customer.

IV. PREVENTIVE MAINTENANCE TROUBLE SHOOTING AIDS:

The Robot Coupe has been designed to provide maximum trouble free performance. Adherence to the assembly and operating instructions will further assure good performance. Additionally, if simple common sense rules are applied to the unit, a long life utilization will be achieved.

(1) Care: While the Robot Coupe is a ruggedly constructed machine, overall handling should be accomplished with a sense of use rather than abuse. The motor housing is made of rugged cast aluminium and will yield a long life if not maltreated. While the machine is reasonably portable, care should be taken not to drop it. Remove the continuous feed assembly and any plates or other attachments before relocating the machine. **Your machine should never be picked up by the continuous feed lead or the cord. Always lift from the bottom of the motor base assembly.** Equal caution should be exercised in handling all of the parts for your own safety and to assure they are not subject to undue force.

(2) Cleaning: The machine should be cleaned per the following instructions or as required by local health department regulations. Proper cleaning of the machine is one of the **MOST IMPORTANT** preventive maintenance measures the user can employ. The high acid content of some foods can cause harm to the seals protecting the electrical parts contained within the housing. It is recommended that the machine be cleaned after each operational use and minimally once per day.

Correct cleaning procedures are required to assure that damage is not inflicted in the cleaning process. The motor base assembly contains the motor and electrical components.

DO NOT IMMERSE THE MOTOR BASE ASSEMBLY IN WATER!

Cleaning of the motor/base assembly must be done with care. **First, unplug the unit** - A sponging with a soluble *soft metal* (Aluminum) *safe* detergent is acceptable, making sure the water is not permitted to penetrate the seals. Clean around the seals with a small brush, taking care to remove all food. Clean the motor shaft with a small brush.

Read the label for the dish machine detergent you are using to determine if it is safe for soft metals. If you can not determine if it is safe for soft metals, then contact your supplier for this information.

Many other cleaning detergents can also cause corrosion of soft metals.

Clean the aluminum parts using only *soft metal* (Aluminum) *safe* detergents.

The continuous feed assembly, pushers, and plates are dishwasher safe if used with a soft metal safe detergent. These attachments can also be washed in a three tank system pot sink.

NOTE: The high temperatures of dish machines will tend to shorten the life of the plastic and rubber parts. Hand washing using a three pot sink will provide for the longest life of these parts.

Pre-rinse the attachments before washing to remove any bulk food on the parts. A stiff bristle brush or power sprayer faucet attachment is effective in knocking the food out of the crevices especially when cleaning the cutting plates. The washer should have an industry standard wash, rinse, and sanitization cycle. Allow the parts to air dry after sanitizing and before reassembly.

(3) Preventive Maintenance: In addition to cleaning the seals, an examination should be made periodically to assure that a seal against food is being maintained. With proper care, and depending on use, the seals should last for a year or more. However, they can and should be replaced when wear or erosion is noted or at least once every three to six months to prevent motor bearing damage. It is recommended that the seals be replaced by an authorized repair agency.

Good operational performance is obtained when the blades are sharp. Continued use can dull the blades. All of the cutting plates are made so that the blades or grids can be replaced when they become dull. Always store the plates in the plate holders. Additional plate holders can be obtained from your food service distributor.

In general, the best preventive measure that can be applied is close adherence to the assembly and operation instructions along with common sense and regular cleaning.

Your Robot Coupe is a piece of kitchen equipment and like all other kitchen equipment, care and caution should be used when operating. Although training requirements are minimal, only responsible individuals familiar with this operation manual should be allowed to operate your machine.

V. TROUBLE SHOOTING AIDS

The following section indicates potential problems and the probable solution which should be implemented by users. Problems which extend beyond these will require an experienced serviceman. A list of authorized service agencies is supplied.

- A. Unit does not start.
 1. Are all the attachments tightly in place? Be sure the continuous feed lead is flush with the continuous feed attachment.
 2. Press the off button and unplug the machine.
 3. Remove continuous feed lead.
 4. Remove any product from inside continuous feed lead and attachment.
 5. Is there any product jamming the plate? If so press the OFF button and unplug the machine. Wear cut-resistant gloves when removing a jam!
 6. Try another outlet.
- B. Continuous feed lead will not fit flush with motor base.
 1. Processing plate is not in it's proper position.
 2. Rim of plate should be slightly above the upper edge of continuous feed attachment.
- C. Unit stops running.
 1. Turn off and unplug the machine.
 2. Follow A. above and try again.
- D. If unit does not operate after following A above
 1. Check outlet for current (breaker for fuse).
 2. Try unit again.
 3. Call local service agency.
- E. Unit starts to spark or smoke.
 1. Turn the unit off, unplug it and call local authorized service agency.
- F. Unit Makes a grinding noise.
 1. Turn off and unplug the machine, disassemble, check the continuous feed lead and processing plate to see if they have been rubbing together.
 2. If this was the case, the processing plate was not fully seated. Discard any food processed. Check for and remove any food particles inside stem of processing plate. Replace the plate insuring that the processing plate is f u l l y seated. Make sure there are no food particles on the motor shaft.

- G. Food is going into machine, but not coming out.
 1. The discharge Plate is not in the continuous feed attachment.
- H. Cucumbers coming out with torn skins.
 1. Blade is dull on plate and must be changed. **NOTE:** cucumber condition before processing should be considered.
 2. Make sure the small "vane" side of the discharge plate is up.

VI. SERVICING OF YOUR ROBOT COUPE

Your Robot Coupe has a one year limited warranty against defects in parts and workmanship. Should the unit require service, check with your distributor to see where local service is available. If not or if you wish your unit to be serviced at the factory, call for a return merchandise authorization (RMA) number, and upon receipt of same, ship it PREPAID and insured to our factory address.

Robot Coupe USA, Inc.
 Service Dept. Phone: 1-800-824-1646
 601-898-8411

Models R4X & R6X

Wiring Diagram for machines with **PLASTIC BASE** for USA and Canada

120V, 1 Ph, 850 RPM, 1 HP, 7.4 Amps

Phone: 1-800-824-1646
 Fax: 601-898-9134
 email: robocoup@misnet.com

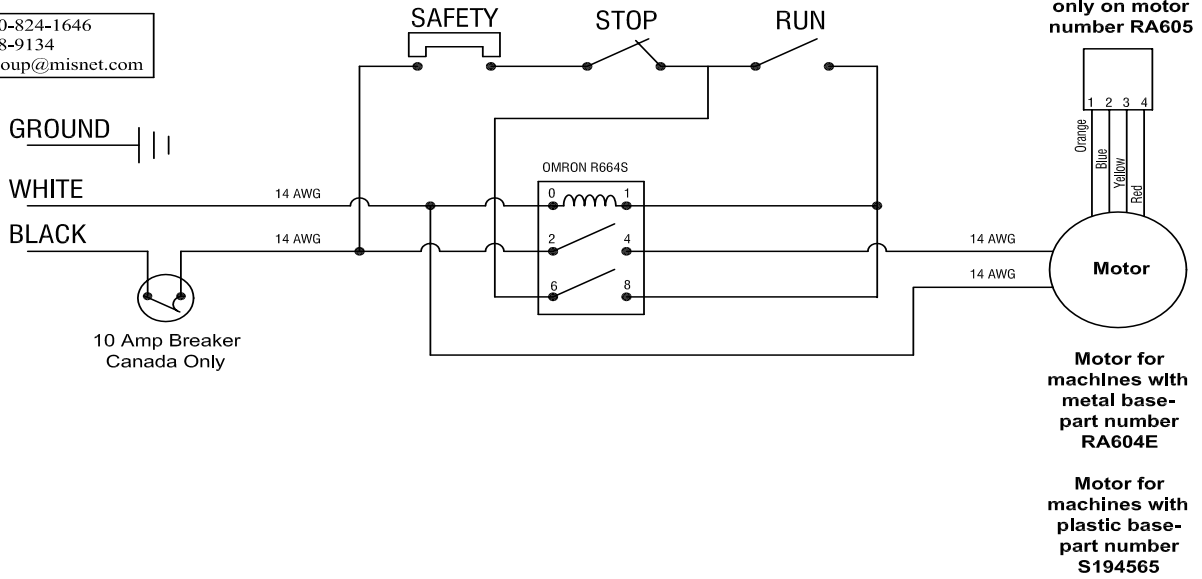

robotcoupe®

William Kugle, Robot Coupe

7/10/02 8:53 AM

E-R4X-R6X.dwg

R4X / R6X

Machines made after March 1, 1999 with **METAL BASE** for USA and Canada with Date Code R-03 and above

120V, 1 Ph, 850 RPM, 1 HP,

R4X 7.5 Amps

R6X 7.6 Amps

Phone: 1-800-824-1646
 Fax: 601-898-9134
 email: robocoup@misnet.com

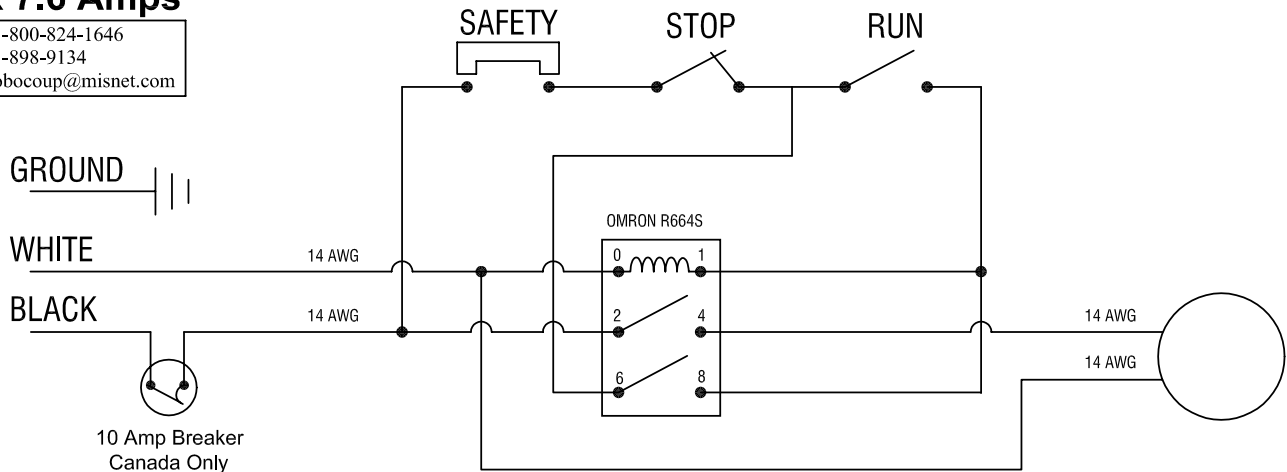

robotcoupe®

William Kugle, Robot Coupe

11/14/01 9:14 AM

E-R4X-R6X.dwg

R4X Series D

Phone: 1-800-824-1646
 Fax: 601-898-9134
 email: robocoup@misnet.com

Series D, Serial Numbers 233xxxxx03 (USA)
 and R4X000600A and Above (Canada)
 1- Speed, 120 Volt, 1 Phase, 60Hz., 1 HP.
 850 RPM, 7.5 Amps
 Use **Series-D** Plates.

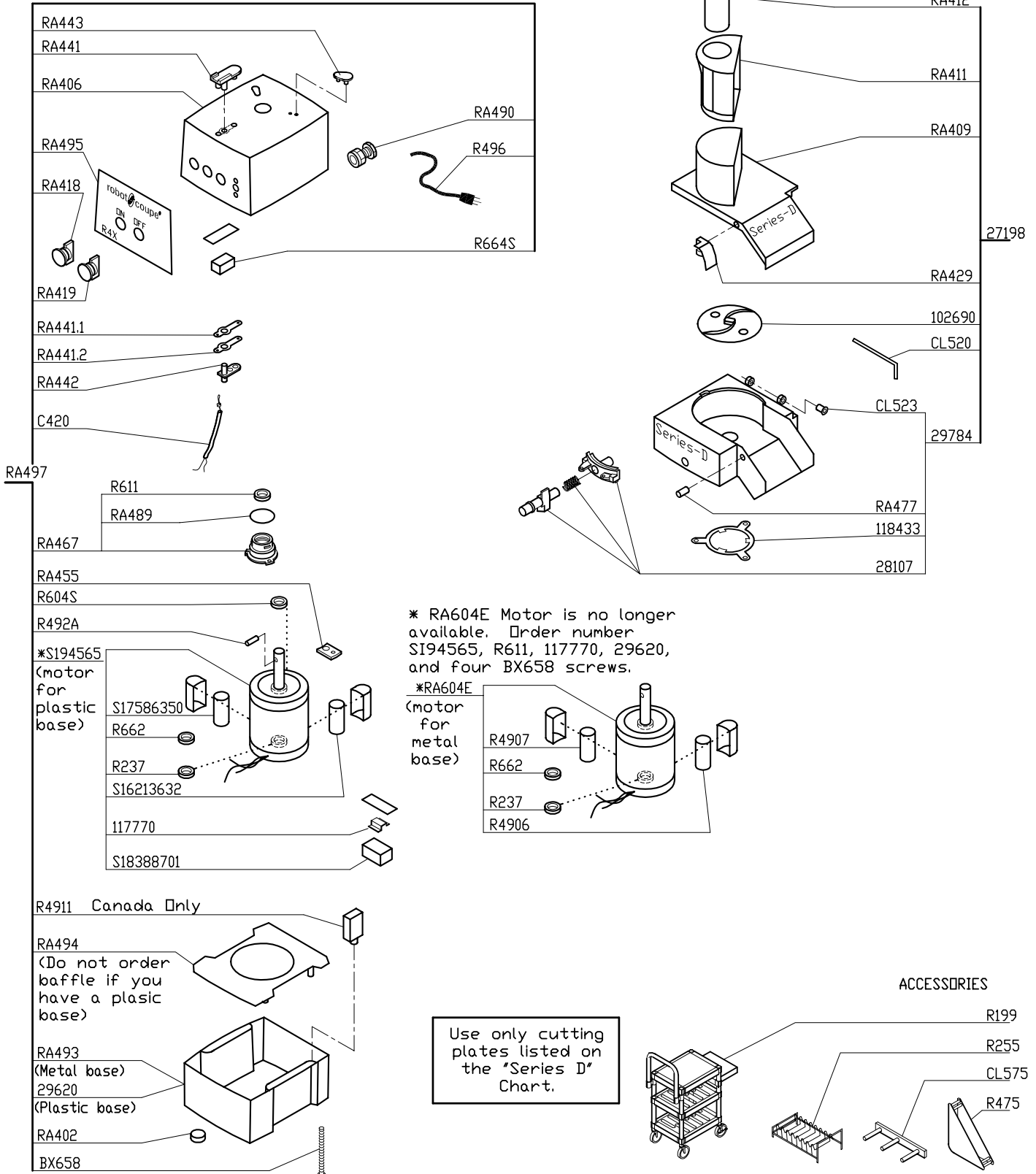
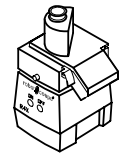

R6X Series D

Phone: 1-800-824-1646
 Fax: 601-898-9134
 email: robocoup@misnet.com

Series D, Serial Numbers 237xxxxx03
 1- Speed, 120 Volt, 1 Phase, 60Hz., 1 HP.
 850 RPM, 7.6 Amps
 Use **Series-D** Plates.

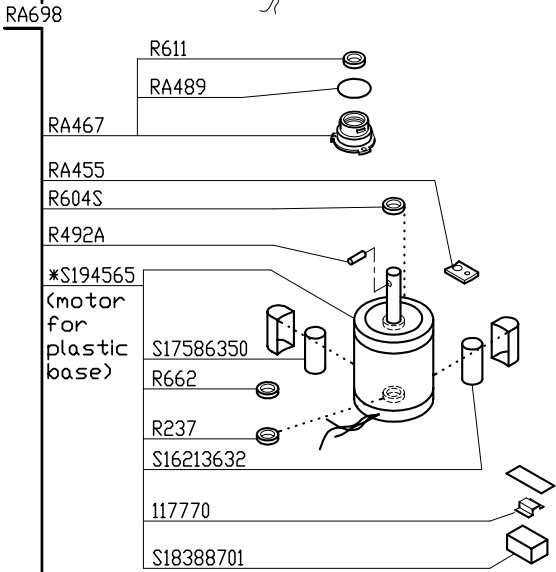
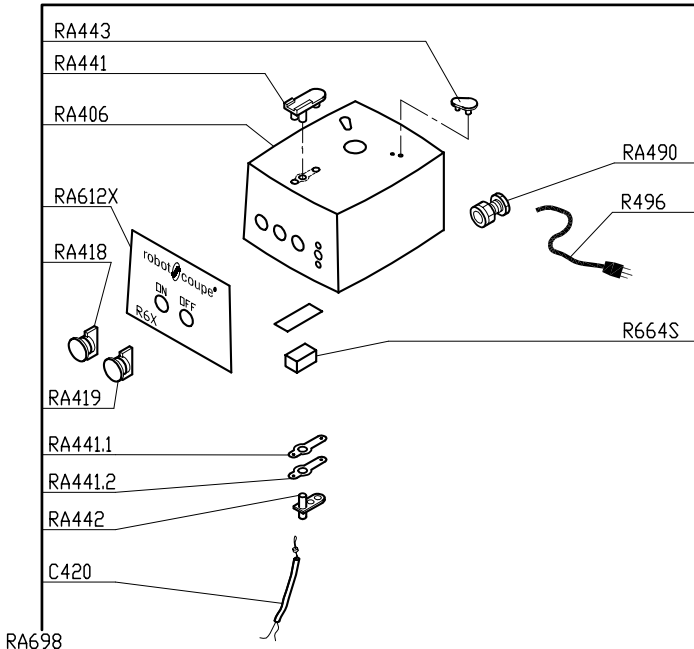
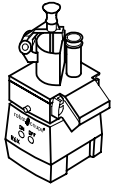

* RA604E Motor is no longer available.
 Order number S194565, R611, 117770, 29620, and four BX658 screws.

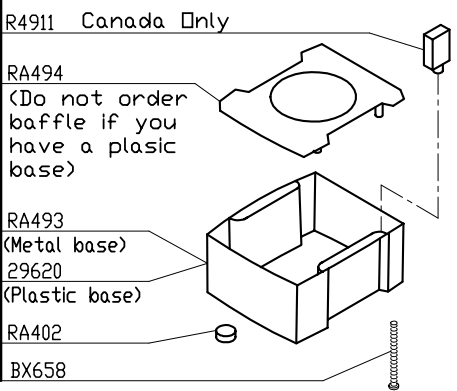
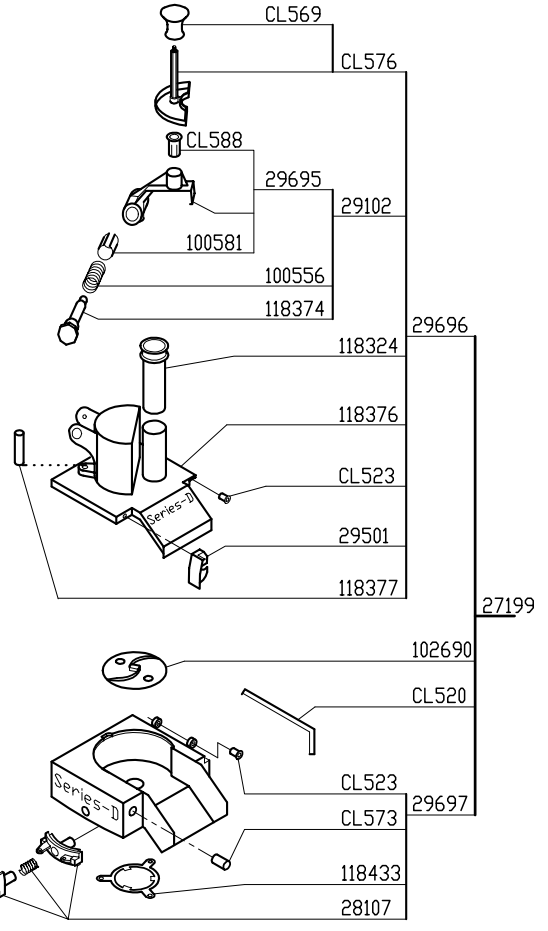
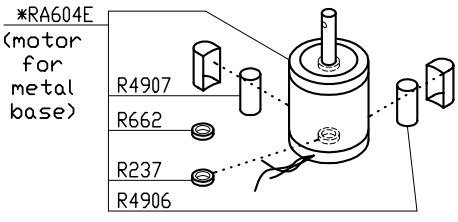

ACCESSORIES
 Use only cutting plates listed on the "Series D" Chart.

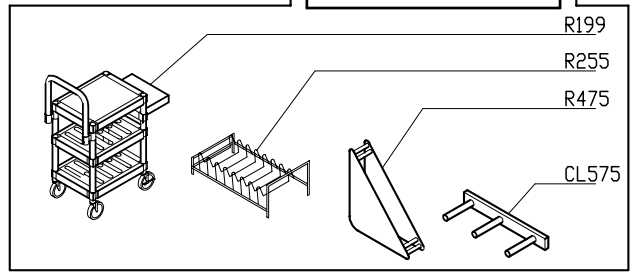

PRICES AND OTHER INFORMATION SUBJECT TO CHANGE WITHOUT NOTICE

Model		Price list for USA only	Model		Price list for USA only
R4X		Series D	R6X		Series D
Series D		Serial Numbers 233xxxx03	Series D		Serial Numbers 237xxxx03
		Use "Series D" Cutting Plates			Use "Series D" Cutting Plates
Part #	Description		Part #	Description	
27198	* (D) Cont Feed Kit/R4		27199	* (D) Cont Feed Kit W/Extra Safety/R6	
28107	(D)Locking Pin Assy		28107	(D)Locking Pin Assy	
29620	(E) Plastic Base, Low Profile		29102	(D)Bracket-Pusher Return Assy	
29784	(D)Cont Feed Bowl (R4 Series D)		29501	(K)Lock for Feed Cover	
102690	(K)Discharge Plate		29620	(E) Plastic Base, Low Profile	
117770	(D) Din Rail 2"L, R4/R6 "D"		29695	(D) Hinge Bracket	
118433	(D)Locking Collar		29696	(D)Cont Feed Lead Assy W/Extra Safety	
BX658	Base Bolt W/Washer		29697	(D)Cont Feed Bowl (R6 Series D)	
C420	Mag Swtch w/Hse (single)		100556	Description NA	
CL520	Hinge Pin		100581	(K)Bushing for Spring	
CL523	Hinge Pin Bushing		102690	(K)Discharge Plate	
CL575	* Plate Rack (wall mount)		117770	(D) Din Rail 2"L, R4/R6 "D"	
R199	* Robo-Cart		118324	(L)Small Pusher	
R237	6203 Bearing R2 Top/Btm		118374	(K)Pivot, Pusher Return Bracket	
R255	* Plate Rack		118376	(D)Cont Feed Lead w/Extra Safety	
R475	* Plate Rack (Individual)		118377	(K)Extra Safety Rod	
R4906	Start Capacitor R4X Mtr		118433	(D)Locking Collar	
R4907	Run Capacitor R4X		BX658	Base Bolt W/Washer	
R4911	Circuit Breaker/R4X/10A		C420	Mag Swtch w/Hse (single)	
R492A	Shaft Pin (new style)		CL520	Hinge Pin	
R496	Cord W/Plug (R4X,S,P,Y)		CL523	Hinge Pin Bushing	
R604S	Seal, Motor		CL569	Pusher Knob	
R611	Motor Support Seal		CL573	Stud Bolt, Latch	
R662	Bearing, Motor Top		CL575	* Plate Rack (wall mount)	
R662	Bearing, Motor Top		CL576	Large Pusher Assembly	
R664S	Relay DPST		CL588	Insert, Plastic	
RA402	Foot		R199	* Robo-Cart	
RA406	Motor Support		R237	6203 Bearing R2 Top/Btm	
RA409	Continuous Feed Lead		R255	* Plate Rack	
RA411	Large Pusher		R475	* Plate Rack (Individual)	
RA412	Small Pusher		R4906	Start Capacitor R4X Mtr	
RA418	Green "On" Switch Assy		R4907	Run Capacitor R4X	
RA419	Red "Stop" Switch Assy		R4911	Circuit Breaker/R4X/10A	
RA429	Latch		R492A	Shaft Pin (new style)	
RA441	Support/Pad,Front		R496	Cord W/Plug (R4X,S,P,Y)	
RA441.1	Gasket		R604S	Seal, Motor	
RA441.2	Metal Plate		R611	Motor Support Seal	
RA442	Support,Magnetic Switch		R662	Bearing, Motor Top	
RA443	Pad,Rear		R664S	Relay DPST	
RA455	Plate, Motor Mounting		RA402	Foot	
RA467	Seal Assembly (Seal Support)		RA406	Motor Support	
RA477	Pin for Latch		RA418	Green "On" Switch Assy	
RA489	O Ring, Seal Support		RA419	Red "Stop" Switch Assy	
RA490	Strain Relief		RA441	Support/Pad,Front	
RA493	Base		RA441.1	Gasket	
RA494	Baffle		RA441.2	Metal Plate	
RA495	Front Data Plate R4X		RA442	Support,Magnetic Switch	
RA497	R4X Motor Base Assy		RA443	Pad,Rear	
RA604E	No longer available		RA455	Plate, Motor Mounting	
S16213632	(D) Start Cap. R4X/R6X		RA467	Seal Assembly (Seal Support)	
S17586350	(D) Run Cap R4X/R6X		RA489	O Ring, Seal Support	
S18388701	(D) Electronic Switch R4X/R6X		RA490	Strain Relief	
S194565	(D) Motor R4X/R6X Low Profile		RA493	Base	
			RA494	Baffle	
			RA604E	No longer available	
			RA612X	Front Data Plate (R6X)	
			RA698	R6X Motor Base Assy	
			S16213632	(D) Start Cap. R4X/R6X	
			S17586350	(D) Run Cap R4X/R6X	
			S18388701	(D) Electronic Switch R4X/R6X	
			S194565	(D) Motor R4X/R6X Low Profile	

* Denotes Accessories

Robot Coupe[®] U.S.A., Inc.

P.O. Box 16625, Jackson, MS 39236-6625
280 South Perkins St., Ridgeland, MS 39157
email: robocoup@misnet.com
website: www.robotcoupeusa.com
1-800-824-1646

ROBOT COUPE U.S.A., INC. LIMITED WARRANTY

YOUR NEW ROBOT COUPE PRODUCT IS WARRANTED TO THE ORIGINAL PURCHASER FOR A PERIOD OF ONE YEAR FROM THE DATE OF PURCHASE.

This LIMITED WARRANTY is against defects in the material and/or workmanship, and includes labor for replacement of defective parts, provided repairs are performed by an authorized service agency (see attached list). The CUSTOMER must inform the Service Agency of the possibility of warranty coverage and provide a copy of the dated sales or delivery receipt BEFORE WARRANTY REPAIRS ARE BEGUN. Replacement parts and accessories are warranted for ninety (90) days from the date of purchase when purchased separately and will be verified by dated sales receipt OR packing slip which lists that item. All parts or accessories replaced under warranty must be returned to the Service Agency.

THE FOLLOWING ARE "NOT" COVERED UNDER WARRANTY:

1. Damage caused by abuse, misuse, dropping, or other similar incidental damage caused by or as a result of failure to follow assembly, operating, cleaning, user maintenance, or storage instructions.
2. Labor to sharpen and/or parts to replace knife assemblies or blades which have become dull, chipped, or worn due to normal use.
3. Material or labor to renew or repair scratched, stained, chipped, dented or discolored surfaces, blades, knives, attachments, or accessories.
4. Transportation charges to or from an authorized service agency for repairs of a machine designated as "CARRY IN SERVICE" (table top models). NOTE: R4N/R6N are now field service units.
5. Labor charges to install or test attachments or accessories (i.e., bowls, cutting plates, blades, attachments) which are replaced for any reason.
6. Charges to change Direction-of-Rotation of Three Phase electric motors (INSTALLER IS RESPONSIBLE).
7. **SHIPPING DAMAGE IS NOT COVERED BY WARRANTY.** Visible and hidden damages are the responsibility of the freight carrier. The consignee must file a damage claim promptly against the carrier, or upon discovery in the case of hidden damage.

KEEP ALL ORIGINAL CONTAINERS AND PACKING MATERIALS FOR CARRIER INSPECTION.

Robot Coupe U.S.A., Inc., Robot Coupe S.A. or any of their affiliates, distributors, officers, directors, agents, employees, or insurers will not be obligated for consequential or other damages, losses, or expenses in connection with or by reason of the use of or inability to use the machine for any purpose.

THIS WARRANTY IS GIVEN EXPRESSLY AND IN LIEU OF ALL OTHER WARRANTIES, EXPRESSED OR IMPLIED, FOR MERCHANTABILITY AND FOR FITNESS TOWARD A PARTICULAR PURPOSE AND CONSTITUTES THE ONLY WARRANTY MADE BY ROBOT COUPE, U.S.A., Inc.