

**OPERATION MANUAL
FOR**

***robot*  *coupe*®**

MODEL

R6VN SERIES D

- I. INTRODUCTION**
- II. ASSEMBLY/DISASSEMBLY INSTRUCTIONS**
- III. OPERATING INSTRUCTIONS**
- IV. PREVENTIVE MAINTENANCE GUIDE**
- V. TROUBLE SHOOTING AIDS**
- VI. SERVICE AGENCY LISTING**

robot coupe U.S.A., Inc.
P.O. Box 16625, Jackson, MS 39236-6625
280 South Perkins St., Ridgeland, MS 39157
email: robocoup@misnet.com
website: www.robotcoupeusa.com
1-800-824-1646

Series-D Plates

IMPORTANT NOTICE: Use this chart only if a **"Series-D"** mark is displayed on your machine.

| Size | Slicing Plates | Replacement Blades (1 Per Plate) |
|-----------|----------------|-------------------------------------|
| 4mm..... | C477SA..... | C449SBA |
| 5mm..... | C437SA..... | C449SBA |
| 8mm..... | C436SA..... | C449SBA |
| 10mm..... | C435SA..... | C449SBA |
| 14mm..... | C434SA..... | C449SBA |
| 19mm..... | C422SA..... | C449SBA |

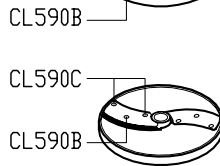
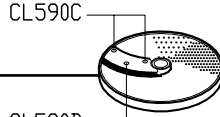

| Size | Slicing Plates | Replacement Blades (2 Per Plate) |
|----------|----------------|-------------------------------------|
| 1mm..... | C444SA..... | C449SBA |
| 2mm..... | C445SA..... | C449SBA |
| 3mm..... | C446SA..... | C449SBA |

| Size | Waved Slicing Plate | Replacement Blades (1 per Plate) |
|----------|---------------------|-------------------------------------|
| 5mm..... | C464W..... | 29786 |

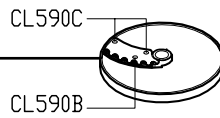
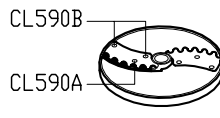

| Size | Waved Slicing Plates | Replacement Blades (2 Per Plate) |
|----------|----------------------|-------------------------------------|
| 2mm..... | C445W..... | 29786 |
| 3mm..... | C446W..... | 29786 |

| Size | Cabbage Grating Plate | Replacement Grids (1 Per Plate) |
|----------|-----------------------|------------------------------------|
| 4mm..... | 28136..... | * |

* Number not Available at printing.

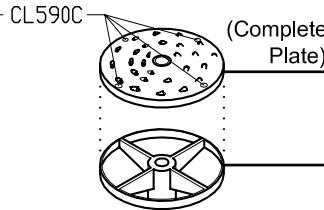
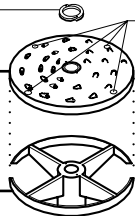

| Size | Grating Plates | Replacement Grids (1 Per Plate) |
|----------------|----------------|------------------------------------|
| EX Fine..... | C495GPA..... | 101062 |
| Hard Cheese... | C452GPA..... | C456GN |
| 1.5mm..... | C494GPA..... | C404GN |
| 2mm..... | C451GPA..... | C455GN |
| 3mm..... | C450GPA..... | C454GN |
| 4mm..... | C475GPA..... | C475.1GN |
| 5mm..... | C453GPA..... | C457GN |
| 7mm..... | C478GPA..... | C418GN |
| 9mm..... | C433GPA..... | C458GN |

| | |
|---------------------------------|---|
| Cabbage Grating Plate Base..... | * |
|---------------------------------|---|

| | |
|-------------------------|--------|
| Grating Plate Base..... | C459BA |
|-------------------------|--------|

| Size | Julienne Plates | Replacement Blades | |
|------------|-----------------|--------------------|------------|
| | | Vertical | Horizontal |
| 2x2mm..... | C460JA..... | C461JBA..... | C440JBA |
| 4x4mm..... | C462JA..... | C463JBA..... | C440JBA |
| 6x6mm..... | C438JA..... | C439JBA..... | C440JBA |
| 8x8mm..... | C466JA..... | C467JBA..... | C440JBA |
| 2x4mm..... | C483JA..... | C4831JBA..... | C440JBA |
| 2x6mm..... | C484JA..... | C4841JBA..... | C440JBA |
| 2x8mm..... | C486JA..... | C4861JBA..... | C440JBA |

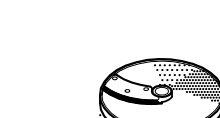
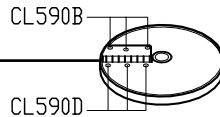

| Size | French Fry Plate Blade Grid | | | |
|--------------|-----------------------------|------------|------------|-----------|
| | Fry Kit | Plate Only | Blade Only | Grid Only |
| 8x8mm..... | 28134..... | 29267..... | 29564..... | 118395 |
| 10x10mm..... | 28135..... | 29276..... | 29564..... | 118396 |

| Size | Dicing Kit | Plate Only | Blade Only | Dicing Grid Only |
|--------------|------------|------------|------------|------------------|
| 5x5mm..... | 28110..... | 28128..... | 29780..... | 28117 |
| 8x8mm..... | 28111..... | 28129..... | 29780..... | 28118 |
| 10x10mm..... | 28112..... | 28130..... | 29780..... | 28119 |
| 14x14mm..... | 28113..... | 28131..... | 29780..... | 28120 |
| 20x20mm..... | 28114..... | 28132..... | 29780..... | 28121 |
| 25x25mm..... | 28115..... | 28133..... | 29780..... | 28122 |

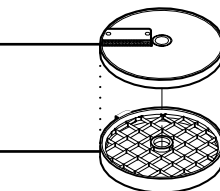

Phone: 1-800-824-1646
 Fax: 601-898-9134
 email: robocoup@misnet.com

I. INTRODUCTION

The Robot Coupe commercial food processor performs a host of culinary feats. It is specifically designed for high speed and quality vegetable processing. The Robot Coupe also provides a wealth of safety and operating features to make volume food preparation a pleasure rather than a chore.

The operators' manual is designed to guide the user through the simple steps of use for a safe, long life utilization.

The manual should be read completely by the operator before any attempt is made to use the machine. Also, the manual should be referred to any time there is a question on operation.

Your Robot Coupe comes with sharp cutting blades and or, cutting “plates”. Always handle with safety in mind. We suggest that a pair of cutting gloves be worn when handling any plates or blades. Also, never put your fingers inside of the bowl or feed lead openings.

If the machine fails to operate as described in this manual, or if the machine malfunctions in any way, remove the machine from use and have it serviced. Additionally, discard all food processed at the time of the malfunction.

II. ASSEMBLY / DISASSEMBLY INSTRUCTIONS

A. Assembling the Continuous Feed Attachment

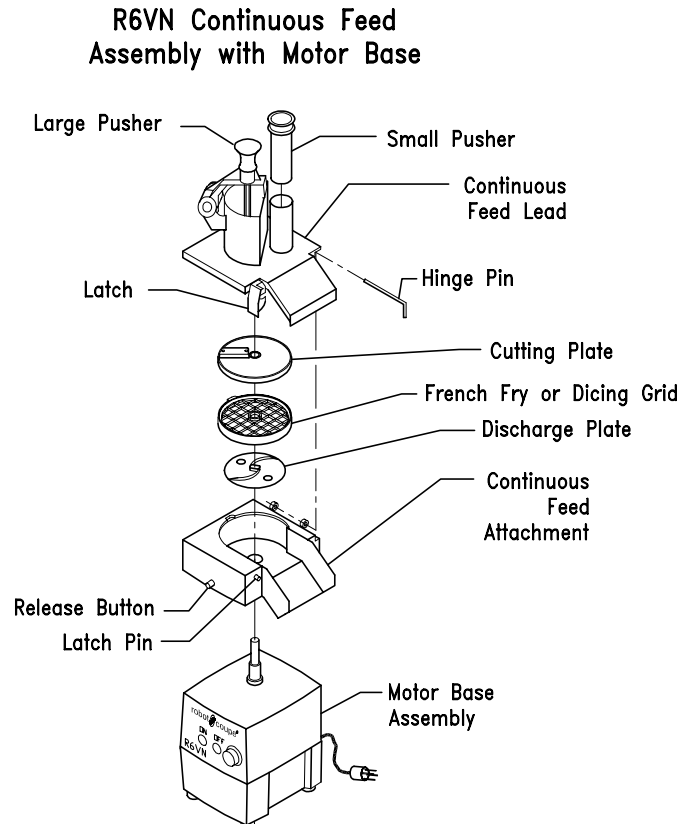

STEP #1 Unplug the machine. Place the motor base assembly at a comfortable height on a sturdy work surface. Remove the plastic discharge plate from inside the continuous feed attachment. Place the continuous feed attachment on the motor base with the release button at front center of the motor base assembly. Rotate the attachment counterclockwise until it locks into place with a snap action. When the attachment is in the proper position, it should be level with the top surface of the motor base assembly. **NOTE:** The machine will not operate correctly unless the continuous feed attachment is fully seated and secured in place.

STEP #2 Place the discharge plate on the motor shaft with the appropriate side up. Use the side with the small straight fins for all julienne cuts or other delicate cuts. The large finned side may be used for dicing or shredding. The product will not exit the machine without the discharge plate.

STEP #3 IF YOU ARE PREPARING TO SLICE OR JULIENNE: Place the plate of your choice on the motor shaft and turn clockwise until it drops into place and is fully seated. The top of the plate should be just above the surface of the continuous feed attachment.

Warning Wear cutting gloves when handling the cutting plates or the blade.

STEP #3 IF YOU ARE PREPARING TO SLICE OR JULIENNE: Place the plate of your choice on the motor shaft and turn clockwise until it drops into place and is fully seated. The top of the plate should be just above the surface of the continuous feed attachment.

STEP #4 IF YOU ARE PREPARING TO DICE OR USE A FRENCH FRY COMBINATION: **NOTE:** The recessed rim on the continuous feed attachment must be free from product and clean so the grid can be firmly seated. **The discharge plate must be in the machine or the product will not exit.**

With the tab on the plastic grid aligned with the cutout in the Continuous Feed Attachment, place the plastic grid onto the recessed rim of the Continuous Feed Attachment. Put the appropriate slicing plate on top of the dicing grid with the stem of the plate DOWN. **NOTE: Only those slicing plates designed with a locking "L" shape slot can be used in conjunction with a dicing grid. Never attempt to use a "regular" slicing plate (1mm, 2mm, 3mm) in conjunction with a dicing grid as it may cause damage to the continuous feed lead and/or the pushers.** Rotate the plate until the cutout in the stem drops into place on the motor shaft pin. Continue rotating the plate a full turn. If rubbing occurs DO NOT PROCEED-call your service agency.

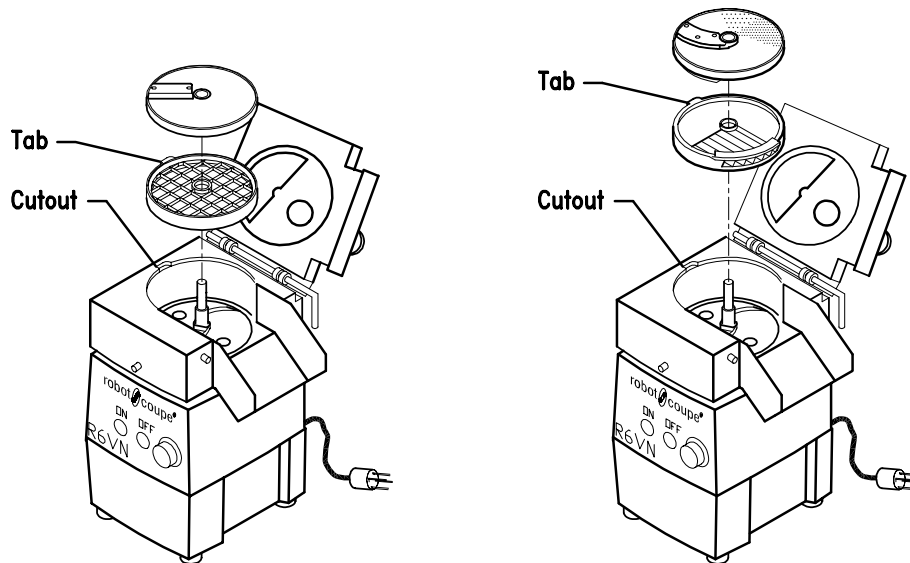

STEP #5 Place the continuous feed lead on the continuous feed attachment and secure in place with the holding pin. The lead should fit flush on the continuous feed attachment.

B. Disassembly of the continuous feed attachment

STEP #1 Turn the unit off and unplug the power cord from the wall outlet.

Step #2 Pull out the hinge pin from continuous feed lead and lift the latch at upper right front of machine. Remove the continuous feed lead.

Step #3 Remove the cutting plate. **Wear cutting gloves.** Rotate the plate slightly counterclockwise, then lift up and off of the motor shaft. Remove the dicing or French fry grid (if any) then, lift out the plastic discharge plate.

Step #4 Press the release button on the continuous feed attachment and at the same time turn the continuous feed clockwise. The continuous feed releases and can be lifted off over the motor shaft.

C. Assembling the Cutter Bowl Attachment

1. The cord should always be unplugged during assembly and disassembly.
2. With the handle turned to the front, put the bowl down on the motor base. Turn the bowl handle to the left of center and the bowl should drop into place level with the top of the motor base.
3. Turn the handle back to the right until it comes to a stop and is centered with the front of the motor base.
4. Put the blade on the motor shaft and turn until it drops into place. The bottom blade should be parallel to and almost touching the bottom of the bowl.
5. With the long tab on the bowl lid turned to the left of center, put the lid on the bowl and turn counterclockwise until it stops. The long tab should be centered over the bowl handle.

6. **DO NOT OPERATE THE MACHINE UNLESS IT IS PROPERLY ASSEMBLED AND THE LID IS FULLY SEATED AND CENTERED OVER THE BOWL!**

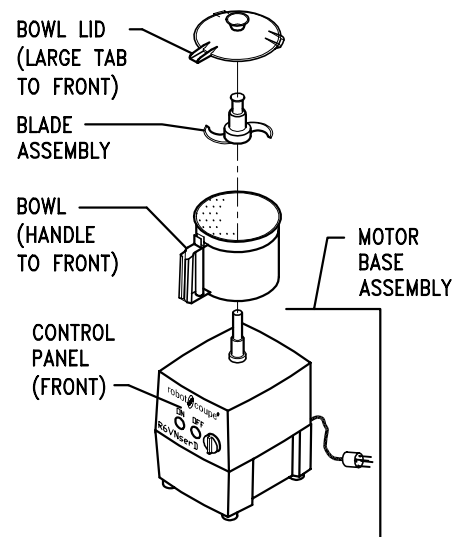

D. Disassembly of the Cutter Bowl Attachment.

The blade should be disassembled and cleaned after each day's use.

- STEP #1** Turn the machine **OFF** and **UNPLUG** the power cord from the wall socket.
- STEP #2** Rotate the bowl lid clockwise and lift off.
- STEP #3** Firmly grasp the top of the blade assembly and lift up and off of the motor shaft.
- STEP #4** Locate the release trigger on the lower back portion of the bowl handle. Pull the trigger and, at the same time, turn the bowl clockwise and lift free.

E. Blade Assembly/Disassembly

1. Unplug the cord and wear cutting gloves!

2. Put the blade tool down over the motor shaft with the raised stop facing the front of the machine.

3. Put the blade on the motor shaft so that the center of the blade assembly rests flat on the blade tool. Insert the metal bar into one of the holes in the blade cap.

4. Turn the blade cap clockwise to tighten or counterclockwise to loosen. The bottom blade should hit the stop on the blade tool and prevent the assembly from turning. Do not over-tighten.

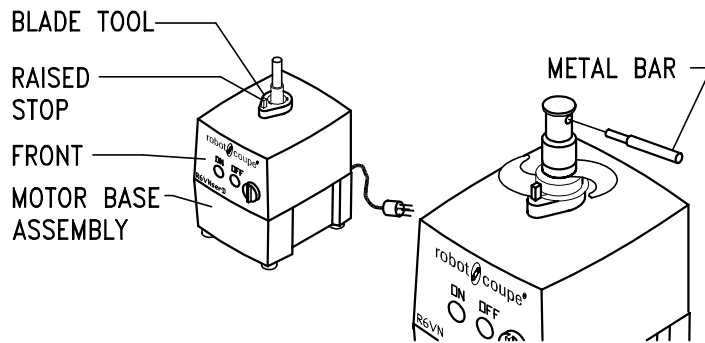

Assemble as shown, with the small nylon spacer directly under the top locking nut. The blades should be installed beveled side up.

BLADE ASSEMBLY

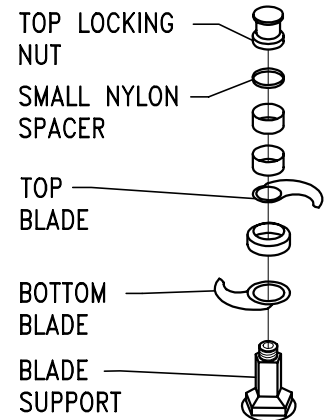

III. OPERATING INSTRUCTIONS

A. GENERAL OPERATION INSTRUCTIONS

The R6VN is a state-of-the-art processor. It utilizes state-of-the-art electronics to control and monitor the motor speed. This unit offers an infinitely variable speed ranging from 370 to 3000 revolutions per minute (RPM). This wide range of speed is used to match the product to be processed to the best cutting speed of the cutting blades. There are a few general rules which apply to speed control.

NOTE: This machine is equipped with manual reset thermal overload protection. If the machine is overloaded or run too long under heavy load conditions then the overload will trip. If this occurs, first remove the bowl and reduce the amount of food being processed. The reset button is located on the bottom right corner of the motor base. Press the button in to reset the overload protector.

BOWL ATTACHMENT: Generally, the medium high and high speeds will be used for the bowl operation. Medium high speed (1725 RPM) is used to chop products, and mix and knead dough and pastry. Also, the medium high speed is used as a first stage of reduction for a puree, sauce or other homogeneous mixture. As a general rule, the bowl should be operated using the medium high speed. Use higher speeds after the product has been reduced or mixed initially on the medium high speed.

Some applications, such as mixing dry powders, may require the use of lower speeds with the bowl attachments. However, a controlled chop and good puree will not be accomplished at the lower speeds with the bowl attachment.

The cutter bowl attachment is used for grinding, pureeing, blending, mixing, of ingredients.

With the power switch off and the bowl and blade secured in place (per previous instructions) you are now ready to add product to the bowl. There are two ways to run your machine. Chop by using a quick start/stop action or running continuously for a fine chop or puree. Most operations start by using the medium high speed (1725 RPM). Use this speed for chopping and general mixing requirements. Medium high is also used to initially reduce meats and vegetables prior to turning the machine to high speed. Some dough applications, like pie crust work best around 1100 RPM.

1. TO CHOP: To achieve a chopped consistency for vegetables, meats, cheese, etc.. Fill the bowl 2/3 to 3/4 full with chunks no larger than 1 to 2 inch square (1/4 full for meats, cheeses and very dense products). Start the machine allowing the machine to come up to speed then quickly press the stop switch. Continue this process until the desired consistency is reached. If the motor stalls, reduce the amount of product in the bowl.

2. TO PUREE OR FINE CHOP: For a fine puree , emulsification or fine chop fill the bowl 2/3 to 3/4 full with chunks no larger than 1 to 2 inches square. With the speed set at medium high, turn the machine on and allow to run a short time until the product is finely chopped, then increase to high speed to finish. High speed is only used to finish a product after it has been reduced at a lower speed. Some purees may require the addition of a liquid to obtain the correct consistency.

3. TO CHOP HARD CHEESE: Place uniform chunks of chilled cheese into the bowl and quickly press the on, then the off buttons. For powdered cheese, do the same, until the cheese is about pea size then allow the motor to run continuously until you have a fine powder.

4. TO CHOP ONIONS, CELERY, CABBAGE, ETC. Quarter onions, and cut other vegetables into 2 to 3 inch chunks. Place the product into the bowl up to 3/4 full and pulse the unit until you reach the desired consistency.

CAUTION: If you turn the unit on and let it run too long the bottom blade will puree the ingredients and the top blade will be of little value leaving an uneven consistency.

5. TO PUREE OR MIX: To puree, make sauces, or to mix and blend, place the ingredients into the bowl, turn the unit on and allow to run continuously.

DO NOT allow the machine to run unattended.

CONTINUOUS FEED ATTACHMENT:

This attachment is always used with speeds less than 1725 RPM (medium high).

Running the machine with this attachment at speeds higher than medium high (1725 RPM) should not be done under any circumstances. The continuous feed attachment should only be run at speeds approaching the medium high setting during a shredding operation such as shredding carrots or cabbage. Running cheese at the medium high speed will produce poor results. The dicing operation should never be run on speeds higher than medium. As a general rule, you should limit the use of the continuous feed attachment to the low and medium speeds.

Running the machine with this attachment at speeds higher than medium high speed can cause damage to the machine. Damage caused by running the machine at the higher speeds is not covered under warranty.

As indicated on the front data plate, use the low speed (370 RPM) for soft products such as tomatoes, kiwi, strawberries, bananas, etc. The softer products cut better at the lower speeds. Additionally, most dicing and some julienne operations perform best at the lower speeds. The medium speed (850 RPM) is used for all other products. Slicing, shredding, and julienne should be performed using the medium speed. Trial runs with your particular product at different speeds should be noted for future use. **Keep in mind that you should not run the continuous feed attachment at speeds higher than the medium high speed.**

NEVER ATTEMPT TO RUN FROZEN PRODUCTS THROUGH THE CONTINUOUS FEED ATTACHMENT.

A. Operation of the Continuous Feed Attachment

The Continuous Feed Attachment will perform the functions of slicing, shredding, dicing, and julienne. Because of the speed of operation, vegetable preparation, entry port loading, and availability of a receptacle or "catch pan", should be determined before the machine is turned on.

Vegetable preparation will be required to assure that the produce will fit a port opening. Additionally, one may or may not choose to core or peel some products. Port selection should be made depending upon the product to be processed. As an example good consistency of small round produce (carrots, cucumbers, etc.) necessitates use of the small entry port to allow operator control. Use of the larger port for this type of produce may result in undesired finished product, e.g. slicing with the grain. In general, more control of the processing operation can be obtained by filling the selected entry port and placing the pusher in position before turning the machine on.

Adherence to certain operational techniques will also enhance the processing operation. For instance, a constant pressure with the pusher upon the produce will yield a consistent output. Application of more pressure will increase the thickness of the product e.g. thicker slice, while reduction in pressure will result in a "finer" product. If no pressure is applied at all and the produce is permitted to bounce around, an inconsistent product will result. When the pusher has settled fully in the entry port, turn the power OFF and reload the entry port for a repeat process.

THE UNIT SHOULD BE IN THE OFF POSITION EXCEPT WHEN PROCESSING IS UNDERWAY.

It is recommended that the machine be operated on a 50% duty cycle. This is easily accomplished since the preparation time (cleaning, coring, peeling, and loading) takes longer than the processing time. This will increase the life of your machine.

DO NOT remove the continuous feed lead when the motor is running. Wait until the motor has come to a full stop.

DO NOT put anything other than food products inside the entry ports.

DO NOT attempt to run frozen products through the cutting plates.

(1) Slicing Operation: The vegetables must be prepared so that they will fit into the proper entry port. Produce such as carrots, cucumbers, etc. should be “squared” at both ends. This will provide a consistent slice throughout the whole product. With cabbage, lettuce or any product that has an undesirable core, the core should be removed. Medium size heads of lettuce or cabbage may be halved to fit in the large entry port.

It is also suggested that the rounded half be “squared” to permit a consistent cut. The “rounded” portion can be dropped into the port at the end with no pressure applied, it will normally come forth “finely” sliced as the rest. Larger heads of cabbage or lettuce may be more effectively processed if they are halved and then cut into thirds. When the preparation has been accomplished, fill the selected entry port, place the pusher in position, and turn the machine on and observe the results.

(2) Grating Operation: Again, vegetable preparation should be done to allow insertion of the produce into the entry port. Consideration should be given to which port is desired. As an example, placement of carrots horizontally in the large port will result in a long grated product, while vertical insertion in the smaller port will result in a short grated product. It is recommended that “cold” cheese be used when grated cheese is desired, otherwise a gumminess may result. A fine coating of cornstarch applied to the cheese before grating will aid in keeping the finished product separate. The cornstarch will not be visible and is tasteless. Grating cheese is one of the most trying operations and because of the nature of the product may cause overheating of the motor if not grated in the recommended manner. It is recommended that a slight pulsating pressure be applied with the pusher while grating, alternating slight pressure then no pressure and continuing in this manner until the block of cheese is completely grated. Typically, twenty (20) pounds of cheese can be grated in approximately five minutes. It is recommended that the cheese be prepared to fit the opening in increments to permit a rest between grating operations. After thirty (30) continuous minutes of cheese grating allow your machine to cool.

(3) Dicing Operation: The dicing operation requires that product be sliced both horizontally and vertically. The smaller the dice required, the more difficult the cut is to achieve. Soft or juicy produce will tend to mush if the dice is too small or the produce is too soft. Cheese and meat represent the opposite extreme. Because of the consistency of cheese and meat, it is recommended that this product not be diced. Damage could occur to the blades and/or the motor and will not be covered under warranty.

During the dicing operation, attention should be given to the finished product. A visible change in the product will occur when the dicing grid requires cleaning. A stiff bristle brush can be very effective in forcing product through the grid.

(4) Julienne Operation: Insertion of the product to be cut must be horizontal if a long “stick” is to be achieved, e.g. julienne zucchini for saute. Vertical insertion will result in finely chopped products, e.g. celery. A finely chopped onion product may also be obtained with this operation by quartering the food and letting it gravity feed.

Never attempt to julienne meats or cheeses.

B. PLATE UTILIZATION:

The standard machine comes with two (2) plates. Check your most current price list for which plates are included as standard. User applications may require additional plates. The Robot Coupe processor will perform a variety of functions: slicing, grating, dicing, and julienne. There are a total of 34 different plates available to perform these functions (see below). The number and type of plates required will vary, depending upon the planned utilization.

- 8 slicing plates
- 8 grating plates
- 5 dicing plates
- 7 julienne plates
- 3 wave slicing plates
- 3 straight French fry plate combinations

The eight (8) slicing plates range from 1mm (approx. 1/64") to 14mm (approx. 1/2"):

| Part Number | MM Slicing | Inches (Approx.) |
|------------------------|------------|------------------|
| C444SA | 1mm | 1/32" |
| C445SA | 2mm | 5/64" |
| C446SA | 3mm | 1/8" |
| C477SA | 4mm | 5/32" |
| C437SA | 5mm | 3/16" |
| C436SA | 8mm | 5/16" |
| C435SA | 10mm | 3/8" |
| C434SA | 14mm | 9/16" |

The **[C444SA \(1/32"\)](#) slicing plate** offers a very fine cut. A possible use for such a fine cut is the preparation of Japanese style vegetables. Typically these products (such as carrots or celery) will be placed in the pusher horizontally to obtain a long thin product.

The **[C445SA \(5/64"\)](#) slicing plate** finds a variety of applications. Cabbage may be sliced with this plate for New York Style Cole Slaw. Carrot curls which adorn many dishes can be achieved with this slicer. The carrot slices should be dropped into cold water to permit curling. A nice carrot coin for salads can also be obtained.

The **[C446SA \(1/8"\)](#) slicing plate** is ideal for salad bars ie., cucumber slices, carrot “coins” (vertically sliced carrots). Lettuce sliced by this plate is readily used for sandwiches, tacos, etc.

The **[C477SA \(5/32"\)](#) and [C437SA \(3/16"\)](#) slicing plates** are also ideal for salad bar use, for the stock pot where thicker “man” size cuts are desired. This blade is excellent also for orange or lemon slices as well as tomatoes, where a nice smooth surface is desired. NOTE: You can not slice meats or cheeses on any food processor.

The **[C434SA](#), [C435SA](#), [C436SA](#) slicing plates** are used in conjunction with the dicing grids. In addition thicker slices can be obtained for use in soups and stews. The **[C434SA \(9/16"\)](#)** slicer also provides an excellent cut of lettuce for use in a salad.

There are eight grating plates available for use with the R6:

| Part Number | Size MM | Inches (Approx.) |
|-------------|-------------|------------------|
| C495GPA | X-Fine | |
| C452GPA | Hard cheese | |
| C494GPA | 1.5 mm | 1/16" |
| C451GPA | 2 mm | 5/64" |
| C450GPA | 3 mm | 1/8" |
| C453GPA | 5 mm | 3/16" |
| C478GPA | 7 mm | 5/16" |
| C433GPA | 9 mm | 3/8" |

The **C452GPA hard cheese grating plate** is designed specifically to grate Parmesan or Romano cheese. **CAUTION:** Softer cheese will tend to gum up the plate. The grated product is very fine. This plate can be used for making cracker or cookie crumbs. Dried bread crumbs can be obtained **CAUTION:** the moisture in fresh bread will cause clogging and poor results.

Use of either the C451GPA, C450GPA, or C453GPA, fine, medium, and coarse grating plates are much dependent upon personal choice and specific application. The medium and coarse grating plates offer a quality grated product with cheese, carrots, cabbage for cole slaw, etc.

A diced product requires two actions. First, a horizontal slice is made and then this slice is forced by the machine through the dicing grid to obtain a vertical cut. This results in a cubed product. The dimensions of this cube are varied via the selection of the slicing plate and dicing grid.

| dicing grid | 5x5 mm | 8x8 mm | 10x10 mm | 14x14 mm | 20x20 mm | 25x25 mm |
|---|--------|--------|----------|----------|----------|----------|
| Plate | | | | | | |
| 5 mm | 28110 | | | | | |
| 8 mm | | 28111 | | | | |
| 10 mm | | | 28112 | | | |
| 14 mm | | | | 28113 | | |
| 20 mm | | | | | 28114 | |
| 25 mm | | | | | | 28115 |
| <div style="background-color: #cccccc; width: 80px; height: 15px; display: inline-block;"></div> The shaded areas indicate combinations that can be used. | | | | | | |

The 5mm dicing combination is generally used for potatoes and squash because of its small size.

The 8mm smaller dicing combinations can be used for finely diced carrots, celery, etc. and readily used in soups or stews. The larger (14 mm or greater) dicing combinations work well with fruits such as apples, pears, pineapple, etc.

When dicing tomatoes, green peppers, onions, or celery always insure that the product is introduced into the machine so that the slicing plate will be slicing across the grain of the vegetable.

CAUTION: The softer the produce, the less acceptable will be the finished product.

When dicing tomatoes, green peppers, onions, or celery always insure that the product is introduced into the machine so that the slicing plate will be slicing across the grain of the vegetable.

After a time of use, the dicing grid will require cleaning. A visible difference in the finished product will occur when cleaning is required. The best way to clean the grid is: remove the slicing plate, take a stiff bristle brush and force the product that is on the grid to go through.

There are seven Julienne plates available:

C460JA 2 x 2 mm (5/64")
 C483JA 2 x 4 mm (5/64" x 5/32")
 C484JA 2 x 6 mm (5/64" x 1/4")
 C486JA 2 x 8 mm (5/64" x 5/16")
 C462JA 4 x 4 mm (5/32")
 C438JA 6 x 6 mm (1/4")
 C466JA 8 x 8 mm (5/16")

Products such as julienne carrots, chopped celery and finely chopped onions are obtainable as well as julienned celery roots.

DO NOT ATTEMPT TO JULIENNE MEATS OR CHEESES!

There are three wave slicing plates:

| Part Number | MM Slicing | Inches (Approx.) |
|-------------|------------|------------------|
| C445W | 2mm Waved | 5/64" |
| C446W | 3mm Waved | 1/8" |
| C464W | 5mm Waved | 3/16" |

The waved slicing plates work just like the straight slicing plates, except that the product has waved or ruffled sides. This can be an attractive alternative to the flat slices that are so prevalent on salad bars. By adding a waved plate you can dramatically alter the presentation of the food. As with the straight slicing plates remember that harder foods slice best when cut thinner and softer foods slice best when cut thicker.

C. Operation of the Cutter Bowl Attachment

The cutter bowl attachment is used for chopping, grinding, pureeing, blending, mixing, and kneading of ingredients required in most every recipe.

With the power switch off and the bowl and blade secured in place (per previous instructions) you are now ready to add product to the bowl. Place the product in the bowl not over 3/4 full and rotate the cover to secure it in place. The bowl is operated using a quick start - stop action. Quickly start and stop the motor by alternately pressing the on and off switches. The reason for this is that you want the lower blade to pick up the product and throw it into the air allowing the top blade to chop the product. Control and consistency can be better achieved in this manner. Remember, if you start with a consistent product your end product will also be consistent.

TO CHOP MEAT: Place chunks of meat approximately 1 to 2 inches square in the bowl. Fill approximately 1/3 to 1/2 full (no more than 2 1/2lbs.) Rotate the lid locking it in place, quickly start and stop the motor using the on/off switches. Repeat this process until product is the desired consistency.

TO CHOP HARD CHEESE: Place chunks of well chilled cheese into the bowl (not over 2 1/2 pounds). With the lid locked in place quickly start and stop the motor. Continue this process until you have reached the desired consistency. For powdered cheese, simply proceed as above until the particles in the bowl are about pea size then start the unit and allow the blades to run continuously until you have a fine powder.

TO CHOP ONIONS, CELERY, CABBAGE, CARROTS. ETC. Quarter onions, and cut other vegetables into 2 to 3 inch pieces. Proceed using a quick start - stop action until the desired consistency is achieved. **CAUTION:** If you turn the machine on with vegetables in it and let it run too long a period of time, the bottom blade will puree the ingredients and the top blade will be of little value leaving a very uneven consistency.

TO PUREE OR MIX: To puree tomatoes, make sauces, or to mix and blend, place the ingredients in the bowl, turn the unit on and allow it to run continuously until the product is rendered to the desired consistency.

TO MAKE MAYONNAISE: Place in the bowl 6 eggs, 3 tsp. of salt, 3 tsp. of sugar, 2/3 tsp. of dry mustard, a pinch of white pepper, and a pinch of red pepper. Turn the unit on. Begin adding 2 qts. of oil pouring very slowly through the top allowing the stream of oil to fall on the top of the cutter blade. When you have added 1/2 of the oil, pour in 4 oz. of vinegar and the balance of the oil. After all of the oil has been added let the machine run for 20 seconds longer. The mayonnaise is now homogenized.

TO MAKE BREAD CRUMBS: Place torn fresh or dried bread in the bowl, and quickly start and stop the unit. Continue this process until you reach the desired consistency or allow the unit to run continuously for finely powered bread crumbs used in stuffing mix.

The blades are sharp. KEEP FINGERS AND HANDS AWAY FROM BLADES. Always allow the blades to come to a complete stop before removing the lid.

D. GENERAL HINTS:

1. Be sure your Robot Coupe is properly assembled before using.
2. Always insure blade and attachment are tightly in place.
3. Do not fill the cutter bowl over 3/4 full.
4. Learn to operate the cutter bowl using a start - stop motion so the consistency of the prepared product can be controlled. Remember it is important to start with uniform pieces for uniform results.
5. Wash the bowl, blade and cover after every use. Do not store food in the bowl.
6. If the motor does not start when the switch is on and lid is in position, disengage the lid (machine is now off) and check to see if the bowl attachment is locked in place. If okay, unplug the unit and see if any food is jamming the blade.
7. If the machine malfunctions for any reason, discard any food being processed at that time.

IV. PREVENTIVE MAINTENANCE/TROUBLE SHOOTING AIDS:

The Robot Coupe has been designed to provide maximum trouble free performance. Adherence to the assembly and operating instructions will further assure good performance. Additionally, if simple common sense rules are applied to the unit, a long life utilization will be achieved.

(1) Care: While the Robot Coupe is a ruggedly constructed machine, overall handling should be accomplished with a sense of use rather than abuse. The continuous feed attachment and the motor housing are made of rugged cast aluminum and will yield a long life if not maltreated. While the machine is reasonably portable, care should be taken not to drop it. Remove the continuous feed and any plates or other attachments before relocating the machine. Your Robot Coupe should never be picked up by the continuous feed lead, the bowl or the cord. Always lift from the bottom of the motor base assembly. Care should be exercised in relocating it. Equal caution should be exercised in handling all of the parts to assure they are not subject to undue force.

(2) Cleaning: Proper cleaning of the machine is one of the **MOST IMPORTANT** preventive maintenance measures the user can employ. The high acid content of food can cause harm to electrical parts contained within the housing. Although these elements are isolated from the outside through seals, vegetable juices will tend to seep. If vegetable juices are permitted to collect on the machine over periods of use, erosion of the seals can occur. It is recommended that the machine be cleaned after each operational use, and minimally once per day.

The blade assembly (R6N only) should be taken completely apart and **washed after each days use** for sanitary reasons, and also to prevent the parts from becoming jammed or "freezing up". Follow the previous assembly/disassembly instructions carefully and **wear cutting gloves when handling the cutting blades.**

Correct cleaning procedures are required to assure that damage is not inflicted in the cleaning process. The motor support/base assembly contains the motor and electrical components.

DO NOT IMMERGE THE MOTOR BASE ASSEMBLY IN WATER.

While the continuous feed lead, pushers and plates are dishwasher safe, some additional cleaning may be required. Cleaning of the plates should be accomplished with care to help prevent cuts. A stiff bristle brush will be effective in knocking the food out of the crevices.

Cleaning of the motor/base assembly must be done with care. First, unplug the unit - a sponging with a soluble detergent is acceptable, making sure the water is not permitted to penetrate the seals. Clean around the seals with a small brush, taking care to remove all food. Do not forget to clean the motor shaft with a small brush.

Read the label for the dish machine detergent you are using to determine if it is safe for soft metals. If you can not determine if it is safe for soft metals, then contact your supplier for this information. Many other cleaning detergents can also cause corrosion of soft metals.

Do not wash the aluminum parts of this machine using a nonmetal safe detergent either in a dish machine or pot sink! Clean the aluminum feed attachment using only soft metal safe detergents.

While the continuous feed lead, pushers and plates are dishwasher safe if used with a metal safe detergent, some additional cleaning may be required. Cleaning of the plates should be accomplished with care to help prevent cuts. A stiff bristle brush will be effective in knocking the food out of the crevices.

Wear cut resistant gloves when cleaning the blade or the cutting plates.

(3) Preventive Maintenance: In addition to cleaning the seals, an examination should be made periodically to assure that a seal against food is being maintained. With proper care, and depending on use, the seals should last for a year or more. However, they can and should be replaced when wear or erosion is noted. It is recommended that the seals be replaced by an authorized repair agency.

Good operational performance is obtained when the blades are sharp. Continued use can dull the blades. All of the slicing and grating plates are made so that the blades can be replaced when they become dull. The cutter bowl blade and the blades on the slicing plates can be sharpened. Instructions are included in the back of this manual. Always store the plates in the plate holders. Additional plate holders can be obtained from your food service distributor.

In general, the best preventive measure that can be applied is close adherence to the assembly and operator's instructions along with common sense. Make sure the continuous feed assembly is fitted on flush before operating the machine.

Your Robot Coupe is a piece of kitchen equipment and like all other kitchen equipment, extreme care and caution should be used when operating. Although training requirements are minimal, only responsible individuals familiar with this operation manual should be allowed to operate your Robot Coupe.

DO NOT remove the attachments from the base when the motor is running.

DO NOT remove the continuous feed lead attachment when the motor is running. Wait until the motor has come to a full stop.

DO NOT overload the bowl with food.

DO NOT put your hands, utensils, or anything other than food product into the feed openings or the exit port.

DO NOT immerse the motor base in water.

DO NOT allow the machine to run unattended.

DO NOT operate the machine unless all parts including the feet are properly attached.

DO NOT use excessive force with the pusher.

DO NOT leave the machine ON when not processing food.

DO NOT lift the machine by anything other than the motor base.

DO NOT operate a machine unless it is completely assembled and all parts

V. Trouble Shooting Aids

The following section indicates potential problems and the probable solution which should be implemented by users. Problems which extend beyond these will require an experienced serviceman. A list of authorized service agencies is supplied.

- A. Unit does not start.**
1. Are all the attachments tightly in place? Be sure the continuous feed lead is flush with the continuous feed attachment. **Bowl:** Is the long bowl lid tab fully in place over the handle. Try again.
 2. **Press the OFF button and unplug the machine.**
 3. Remove continuous feed lead.
 4. Remove any product from inside continuous feed lead and attachment.
 5. Is there any product jamming the plate? **Wear cut-resistant gloves when removing a jam.**
 6. Try another outlet.
- B. Continuous feed lead will not fit flush with motor base.**
1. Processing plate is not in it's proper position.
 2. Rim of plate should be slightly above the upper edge of continuous feed attachment.
- C. Unit stops running.**
1. **Press the Off button.**
 2. **Unplug.**
 3. Follow A. above and try again.
- D. If unit does not operate after following A above**
1. Check outlet for current (breaker for fuse).
 2. Try unit again.
 3. Call local service agency.
- E. Unit starts to spark or smoke.**
1. Turn unit off, unplug it, call local authorized service agency.
- F. Unit Makes grinding noise.**
1. Turn off unit, disassemble, check continuous feed lead and processing plate to see if they have been rubbing together.
 2. If this was the case the processing plate was not fully seated. **Discard any food processed.** Check for food particles inside stem of processing plate. Replace plate insuring that processing plate is fully seated. Make sure there are not food particles on the motor shaft.

- G. Food is going into machine, but not coming out.
 1. Discharge Plate is not in unit.
- H. Cucumbers coming out with torn skins.
 1. Blade is dull on plate and must be changed. **NOTE:** cucumber condition before processing should be considered.
 2. Make sure the small “vane” side of the discharge plate is up.

In general, the best preventive measure that can be applied is close adherence to the assembly and operator's instructions along with common sense. Make sure the continuous feed assembly is fitted on flush before operating the machine.

- A. Unit does not start.
 1. Are all the attachments tightly in place? Be sure the continuous feed lead is flush with the continuous feed attachment. **Bowl:** Is the long bowl lid tab fully in place over the handle. Try again.
 2. **Press the OFF button and unplug.**
 3. Remove continuous feed lead.
 4. Remove any product from inside continuous feed lead and attachment.
 5. Is there any product jamming the plate? If so, press the **OFF** button and **unplug** the machine before removing jam.
 6. Try another outlet.
- B. Continuous feed lead will not fit flush with motor base.
 1. Processing plate is not in it's proper position.
 2. Rim of plate should be slightly above the upper edge of continuous feed attachment.
- C. Unit stops running during (while processing).
 1. Turn unit **Off**.
 2. **Unplug.**
 3. Follow A. above and try again.
- D. If unit does not operate after following A above
 1. Check outlet for current (breaker for fuse).
 2. Try unit again.
 3. Call local service agency.
- E. Unit starts to spark or smoke.
 1. Turn unit off, unplug it, call local authorized service agency.

VI. SERVICING OF YOUR ROBOT COUPE

Your Robot Coupe has a one year limited warranty against defects in parts and workmanship. Should the unit require service, check with your distributor to see where local service is available. If not or if you wish your unit to be serviced at the factory, call for a return merchandise authorization (RMA) number, and upon receipt of same, ship it PREPAID and insured to our factory address.

Robot Coupe USA, Inc. Service Dept.
 Phone: 1-800-824-1646
 601-898-8411

Sharpening The Blade on The Cutting Plate

ALWAYS WEAR CUTTING GLOVES WHEN HANDLING THE BLADES

The blades can be sharpened professionally if you prefer.

1. **Put on your cut-resistant gloves.**
2. Using a screwdriver, remove the 2 or 3 screws holding the slicing blade to the aluminum disk. **IMPORTANT: SOME SCREWS MAY BE LONGER THAN OTHERS.** Note the hole from which each screw is removed. Reinstall all screws to their original positions.
3. Use the robot coupe stone or any good sharpening stone.
4. Hold the blade, bevel side up, flat on the edge or corner of a sturdy table.
5. With the other hand hold the stone at a 30-45 degree angle against the top bevel of one blade.
6. Pull the stone into the blade edge moving from hub to tip, several strokes, until the blade is sharp.
7. Turn the blade over and rub the stone flat against the underside of the blade to remove the feather edge formed at step 5.
8. Wash the blade before reinstalling the blade in the aluminum disk.
9. Reinstall all screws to their original positions.

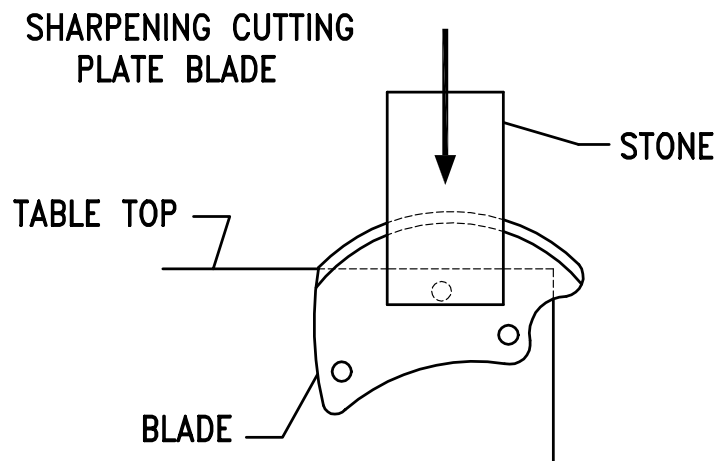

Sharpening The "S" Blade

ALWAYS WEAR CUTTING GLOVES WHEN HANDLING THE BLADES.

1. Put on your cutting gloves.
2. Use the robot coupe stone or any good sharpening stone.
3. Hold the blade flat on the edge or corner of a sturdy table.
4. With the other hand hold the stone at a 30 degree angle against the top bevel of one blade.
5. Pull the stone into the blade edge moving from hub to tip, several strokes, until the blade is sharp.
6. Turn the blade over and rub the stone flat against the underside of the blade to remove the feather edge formed at step 5.
7. Repeat the procedure for the other blade.
8. Wash the blade before use.

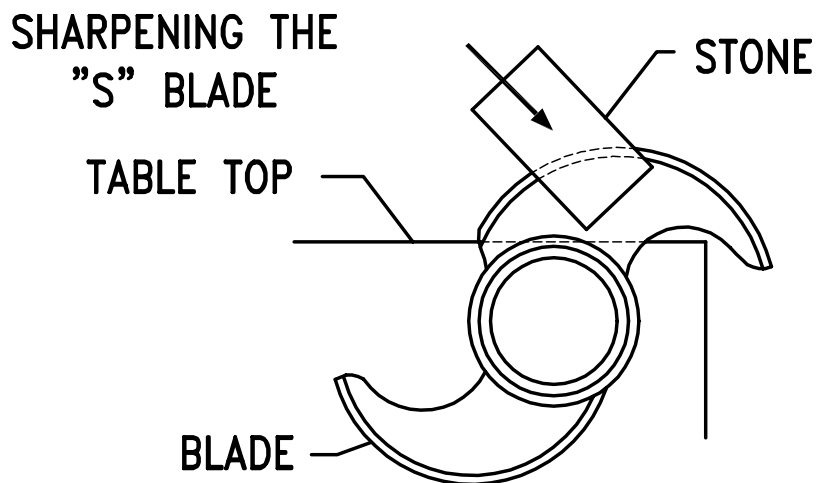

R6VN
Variable Speed, 120 Volt, 1 Phase, 60Hz.,
1 HP, 370/3450 RPM, 12 Amps
Serial Numbers R6VxxxxxA & 236xxxxx03

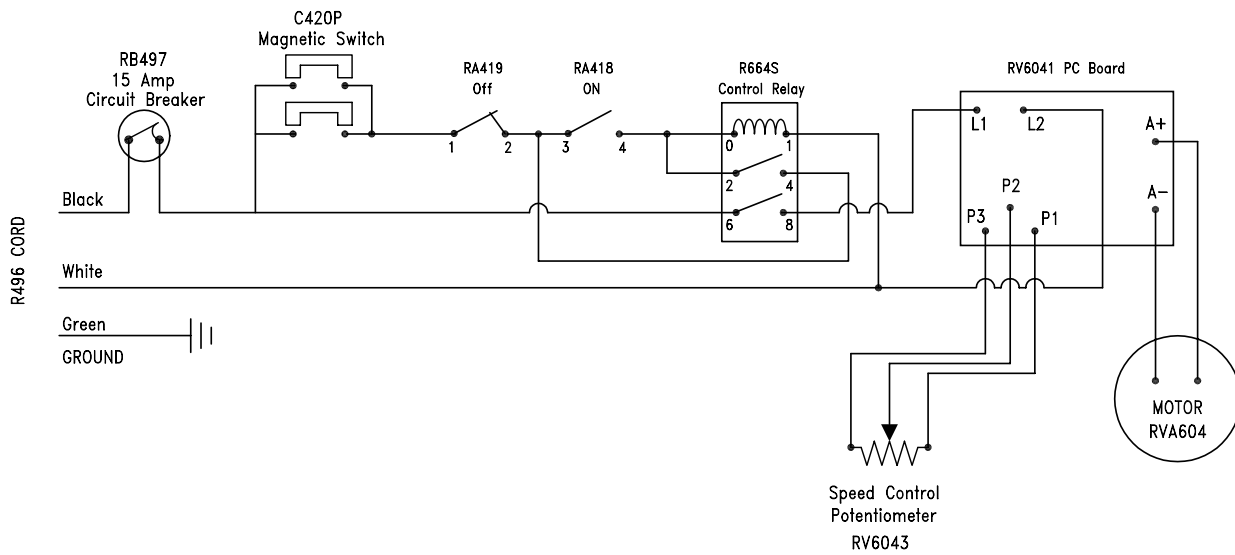

Phone: 1-800-824-1646
 Fax: 601-898-9134
 email: robocoup@misnet.com

R6VN Series D

Series D, Serial Numbers 236xxxxx03 and up
 Variable- Speed, 120 Volt, 1 Phase, 60Hz., 1 HP.
 370-3450 RPM, 12 Amps

Use **Series-D** Plates.

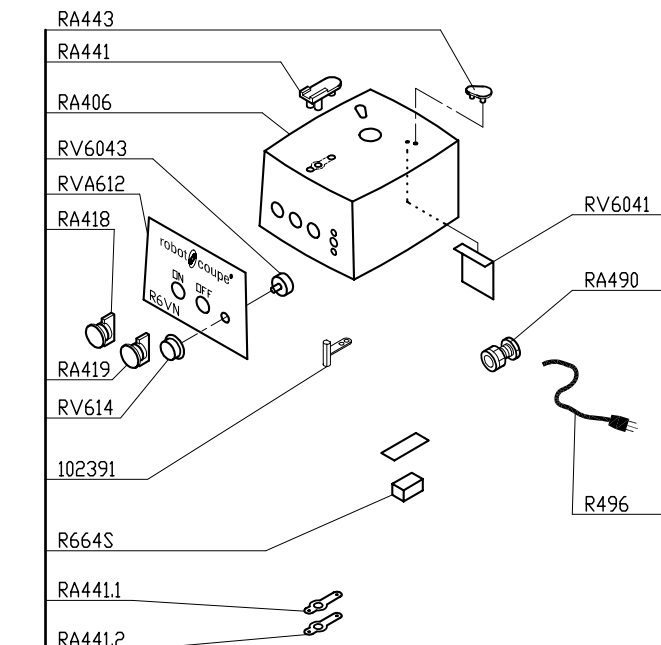
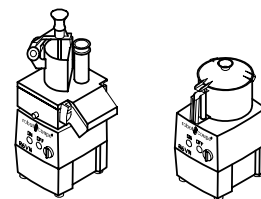

*102071 includes 103903 which is used if replacing the older versions of the blade support.

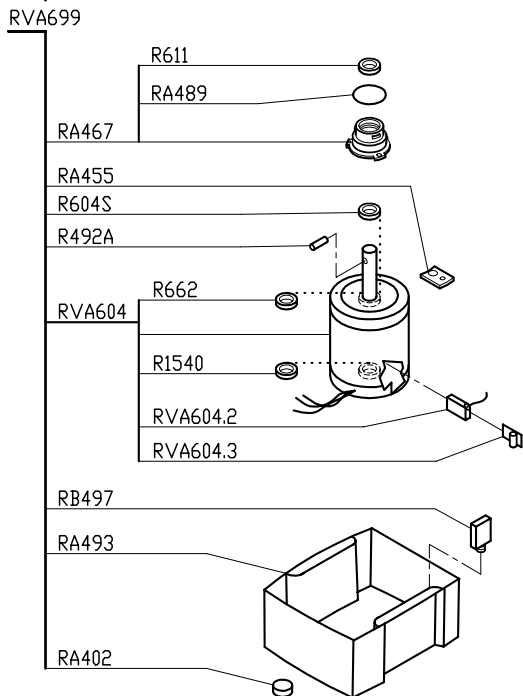
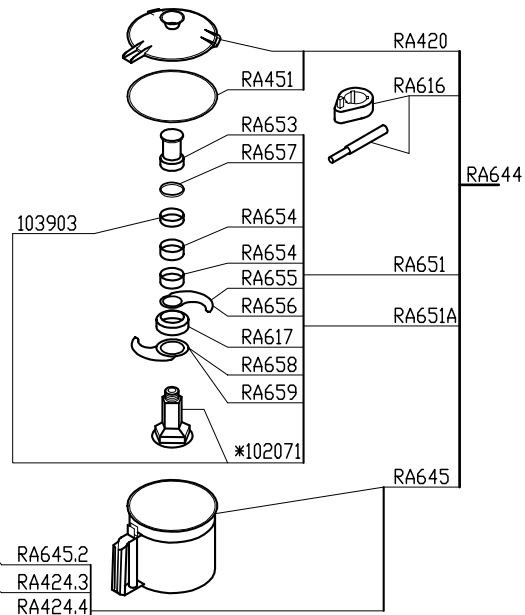

ACCESSORIES

Use only cutting plates listed on the "Series D" Chart.

R199
 R255
 R475
 CL575

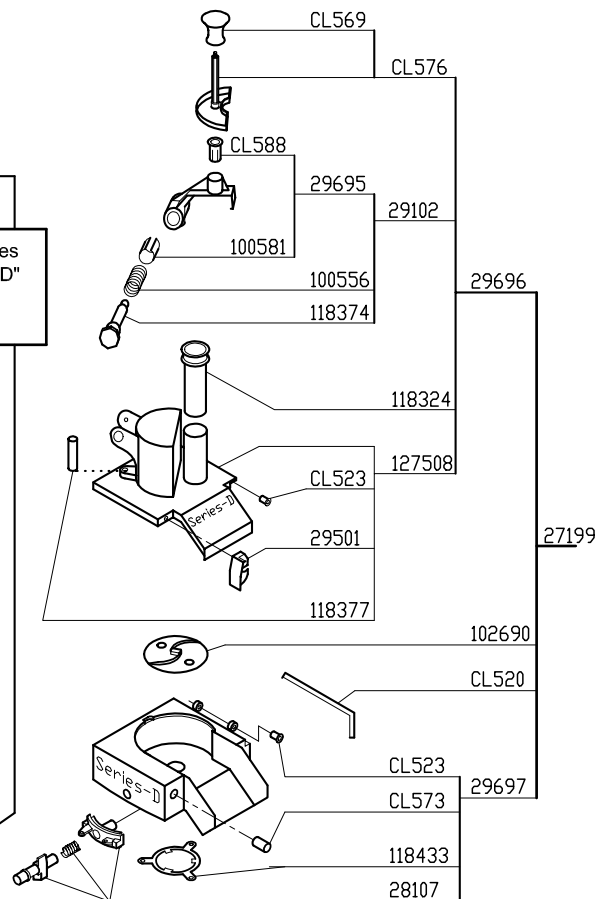

PRICES AND OTHER INFORMATION SUBJECT TO CHANGE WITHOUT NOTICE

| Model | Price list for USA only |
|--------------------------------|--|
| R6VN Series D | Series D Serial Numbers 236xxxx03 Use "Series D" Cutting Plates |
| Part # | Description |
| 27199 | * (D) Cont Feed Kit W/Extra Safety/R6 |
| 28107 | (D)Locking Pin Assy |
| 29102 | (D)Bracket-Pusher Return Assy |
| 29501 | (K)Lock for Feed Cover |
| 29695 | (D) Hinge Bracket |
| 29696 | (D)Cont Feed Lead Assy W/Extra Safety |
| 29697 | (D)Cont Feed Bowl (R6 Series D) |
| 100556 | Description NA |
| 100581 | (K)Bushing for Spring |
| 102071 | (D) Blade Support |
| 102391 | (D) Magnetic Switch R6VN Series D |
| 102690 | (K)Discharge Plate |
| 103903 | (D) 10mm S.S. Spacer (R6N) |
| 118324 | (L)Small Pusher |
| 118374 | (K)Pivot, Pusher Return Bracket |
| 118377 | (K)Extra Safety Rod |
| 118433 | (D)Locking Collar |
| 127508 | (D)Cont Feed Lead |
| C420P | Mag Swtch w/Hse (2 prl) |
| CL520 | Hinge Pin |
| CL523 | Hinge Pin Bushing |
| CL569 | Pusher Knob |
| CL573 | Stud Bolt, Latch |
| CL575 | * Plate Rack (wall mount) |
| CL576 | Large Pusher Assembly |
| CL588 | Insert, Plastic |
| R1540 | Bearing (6206) |
| R199 | * Robo-Cart |
| R255 | * Plate Rack |
| R475 | * Plate Rack (Individual) |
| R492A | Shaft Pin (new style) |
| R496 | Cord W/Plug (R4X,S,P,Y) |
| R604S | Seal, Motor |
| R611 | Motor Support Seal |
| R662 | Bearing, Motor Top |
| R664S | Relay DPST |
| RA402 | Foot |
| RA406 | Motor Support |
| RA418 | Green "On" Switch Assy |
| RA419 | Red "Stop" Switch Assy |
| RA420 | Lid |
| RA424.3 | Spring, Bowl Pin |
| RA424.4 | Nut For Bowl Pin |
| RA441 | Support/Pad,Front |
| RA441.1 | Gasket |
| RA441.2 | Metal Plate |
| RA443 | Pad,Rear |
| RA451 | Seal,Lid |
| RA455 | Plate, Motor Mounting |
| RA467 | Seal Assembly (Seal Support) |
| RA489 | O Ring, Seal Support |
| RA490 | Strain Relief |
| RA493 | Base |
| RA616 | Blade Tool Assy. |
| RA617 | Spacer,Blade |
| RA644 | * Bowl Kit |
| RA645 | Bowl |
| RA645.2 | Pin, Bowl |
| RA651 | *Smooth Blade Assembly |
| RA651A | *Serrated Blade Assy |
| RA653 | Blade Locking Nut |
| RA654 | SS Spacer(15mm) |
| RA655 | Top Blade (Straight) |
| RA656 | Top Blade(Serrated) |
| RA657 | Plastic Spacer(5mm) |
| RA658 | Bottom Blade (Straight) |
| RA659 | Bottom Blade(Serrated) |
| RB497 | 15amp Breaker (CSA) |
| RV6041 | PC Board W/Switch |
| RV6043 | Speed Control Pot. |
| RV614 | Switch Knob |
| RVA604 | Motor Only (New Style R6VN) |
| RVA604.2 | Brush |
| RVA604.3 | Spring, Brush |
| RVA612 | Front Data Plate (R6VN) |
| RVA699 | R6VN Motor Base Assy |

* Denotes Accessories

Robot Coupe[®] U.S.A., Inc.

**P.O. Box 16625, Jackson, MS 39236-6625
280 South Perkins St., Ridgeland, MS 39157
email: robocoup@misnet.com
website: www.robotcoupeusa.com
1-800-824-1646**

ROBOT COUPE U.S.A., INC. LIMITED WARRANTY

YOUR NEW ROBOT COUPE PRODUCT IS WARRANTED TO THE ORIGINAL PURCHASER FOR A PERIOD OF ONE YEAR FROM THE DATE OF PURCHASE.

This LIMITED WARRANTY is against defects in the material and/or workmanship, and includes labor for replacement of defective parts, provided repairs are performed by an authorized service agency (see attached list). The CUSTOMER must inform the Service Agency of the possibility of warranty coverage and provide a copy of the dated sales or delivery receipt BEFORE WARRANTY REPAIRS ARE BEGUN. Replacement parts and accessories are warranted for ninety (90) days from the date of purchase when purchased separately and will be verified by dated sales receipt OR packing slip which lists that item. All parts or accessories replaced under warranty must be returned to the Service Agency.

THE FOLLOWING ARE “NOT” COVERED UNDER WARRANTY:

1. Damage caused by abuse, misuse, dropping, or other similar incidental damage caused by or as a result of failure to follow assembly, operating, cleaning, user maintenance, or storage instructions.
2. Labor to sharpen and/or parts to replace knife assemblies or blades which have become dull, chipped, or worn due to normal use.
3. Material or labor to renew or repair scratched, stained, chipped, dented or discolored surfaces, blades, knives, attachments, or accessories.
4. Transportation charges to or from an authorized service agency for repairs of a machine designated as “CARRY IN SERVICE” (table top models). NOTE: R4N/R6N are now field service units.
5. Labor charges to install or test attachments or accessories (i.e., bowls, cutting plates, blades, attachments) which are replaced for any reason.
6. Charges to change Direction-of-Rotation of Three Phase electric motors (INSTALLER IS RESPONSIBLE).
7. **SHIPPING DAMAGE IS NOT COVERED BY WARRANTY.** Visible and hidden damages are the responsibility of the freight carrier. The consignee must file a damage claim promptly against the carrier, or upon discovery in the case of hidden damage.

KEEP ALL ORIGINAL CONTAINERS AND PACKING MATERIALS FOR CARRIER INSPECTION.

Robot Coupe U.S.A., Inc., Robot Coupe S.A. or any of their affiliates, distributors, officers, directors, agents, employees, or insurers will not be obligated for consequential or other damages, losses, or expenses in connection with or by reason of the use of or inability to use the machine for any purpose.

THIS WARRANTY IS GIVEN EXPRESSLY AND IN LIEU OF ALL OTHER WARRANTIES, EXPRESSED OR IMPLIED, FOR MERCHANTABILITY AND FOR FITNESS TOWARD A PARTICULAR PURPOSE AND CONSTITUTES THE ONLY WARRANTY MADE BY ROBOT COUPE, U.S.A., Inc.