

robot *coupe*®



R 8

R 10

R 15

R 20

Robot-coupe USA. Inc.

P.O. Box 16625, Jackson, MS 39236-6625 - 264 South Perkins St., Ridgeland, MS 39157

e-mail: info@robotcoupeusa.com - website: www.robotcoupeusa.com - Phone : 1-800-824-1646

IMPORTANT WARNING

 WARNING
Keep these instructions in a safe place

WARNING: In order to limit accidents such as electric shocks or personal injury, and in order to limit material damage due to misuse of the appliance, please read these instructions carefully and follow them strictly. Reading the operating instructions will help you get to know your appliance and enable you to use the equipment correctly. Please read these instructions in their entirety and make sure that anyone else who may use the appliance also reads them beforehand.

UNPACKING

- Carefully remove the equipment from the packaging and take out all the boxes or packets containing attachments or specific items.
- **WARNING** - some of the tools are very sharp e.g. blades, discs... etc.
- Store manuals, tools and spare parts in a safe place available to the users of the machine.

INSTALLATION

- Install the machine on a clear floor space with sufficient room to safely operate and clean the machine.

CONNECTION

- Always check that your power supply corresponds to that indicated on the identification plate on the motor unit and that it can withstand the amperage.
- The machine must be grounded.
- Always check that the motor shaft rotates in anticlockwise direction before the blades are installed.

HANDLING

- Always take care when handling the blades, as they are extremely sharp.
- Wear cut-proof gloves when handling the blades.

ASSEMBLY PROCEDURES

- Follow the various assembly procedures carefully (see page 6) and make sure that all the attachments are correctly positioned.

USE

- Never try to override the locking and safety systems.
- Never insert any object into the container where the food is being processed.
- Never push the ingredients down with your hand.
- Do not overload the appliance.
- Maximum fill level is $\frac{2}{3}$ full, less if the product is very dense or sticky.

CLEANING

- As a precaution, always unplug your appliance before cleaning it.
- Always clean the appliance and its attachments at the end of each cycle.
- Never immerse the motor unit in water.
- For parts made from aluminum, use metal safe detergents intended for aluminum.

- Caustic detergents used in automatic dishwashers quickly degrade plastic parts. Hand wash plastic parts if possible.
- Robot-Coupe can in no way be held responsible for the user's failure to follow the basic rules of cleaning and hygiene.

MAINTENANCE

- Do not open the motor housing. There are no user serviceable components inside the electrical housing. Refer control component repairs to qualified technicians.
- Remove and clean shaft seals monthly. Replace seals each 3 to 6 months. Lubricate with food safe grease.
- It is particularly important to maintain and check the attachments since certain ingredients contain corrosive agents, e.g. citric acid.
- Never operate the appliance if the power cord or plug has been damaged or if the appliance fails to work properly or has been damaged in any way.
- If the machine malfunctions in any way discard any food being processed and refer service to qualified maintenance technicians.

robot  ***coupe***®

OPERATING INSTRUCTIONS

We reserve the right to alter at any time without notice the technical specifications of this appliance.
None of the information contained in this document is of a contractual nature. Modifications may be made at any time.
© All rights reserved for all countries by: ROBOT-COUPE S.N.C.

SUMMARY

WARRANTY

IMPORTANT WARNING

INTRODUCTION TO YOUR NEW R 8 • R 10 • R 15 • R 20 CUTTER MIXER

SWITCHING ON THE MACHINE

- Advice on electrical connections
- Control panel

ASSEMBLY

- Machine
- Blade

USES AND EXAMPLES

OPTIONS

- Stainless-steel mini bowl
- Serrated blade - Fine serrated blade
- Vacuum kit R-Vac®

CLEANING

MAINTENANCE

- Dismantling the blade assembly
- Blade
- Seal
- Lid seal

OPERATING INSTRUCTIONS FOR THE VACUUM KIT R-VAC®

DIAGNOSTIC SYSTEM

FITTING AND USING THE BLADE ASSEMBLY

- 2-blade assembly
- 3-blade assembly

TECHNICAL SPECIFICATIONS

- Weight
- Dimensions
- Working space
- Noise level
- Electrical data

SAFETY

SERVICE

TECHNICAL DATA

- Exploded views
- Electrical and wiring diagrams

ROBOT-COUPE U.S.A., INC. LIMITED WARRANTY

YOUR NEW ROBOT COUPE PRODUCT IS WARRANTED TO THE ORIGINAL PURCHASER FOR A PERIOD OF ONE YEAR FROM THE DATE OF PURCHASE.

This LIMITED WARRANTY is against defects in the material and/or workmanship, and includes labor for replacement of defective parts, provided repairs are performed by an authorized service agency (see attached list).

The Customer must inform the Service Agency of the possibility of warranty coverage and provide a copy of the dated sales or delivery receipt BEFORE WARRANTY REPAIRS ARE BEGUN.

Replacement parts and accessories are warranted for ninety (90) days from the date of purchase when purchased separately and will be verified by dated sales receipt OR packing slip which lists that item.

All parts or accessories replaced under warranty must be returned to the Service Agency.

THE FOLLOWING ARE NOT COVERED BY THE ROBOT-COUPE U.S.A. INC LIMITED WARRANTY:

- 1** - Damage caused by abuse, misuse, dropping, or other similar damage caused by or resulting from failure to follow assembly, operating, cleaning, user maintenance or storage instructions.
- 2** - Labor to sharpen and/or replacements for blades that have become blunt, chipped or worn after a normal or excessive period of use.
- 3** - Materials or labor to replace or repair scratched, stained, chipped, pitted, dented or discolored surfaces, blades, knives, attachments or accessories.
- 4** - Any alteration, addition, or repair that has not been carried out by the company or an approved service agency.
- 5** - Transportation of the appliance to or from an approved service agency.
- 6** - Labor charges to install or test new attachments or accessories (i.e., bowls, plates, blades, attachments), which have been replaced for any reason.

7 - The cost of changing direction-of-rotation of three-phase electric motors (Installer is responsible).

8 - SHIPPING DAMAGES. Visible and/or hidden damage is the responsibility of the freight carrier. The consignee must inform the carrier and consignor immediately, or upon discovery in the case of hidden defects.

KEEP ALL ORIGINAL CONTAINERS AND PACKING MATERIALS FOR CARRIER INSPECTION.

Neither ROBOT-COUPE U.S.A., INC. nor its affiliated companies or any of its distributors, directors, agents, employees, or insurers will be liable for indirect damage, losses, or expenses linked to the appliance or the inability to use it.

The ROBOT-COUPE U.S.A., INC. warranty is given expressly and in lieu of all other warranties, expressed or implied, for merchantability and for fitness toward a particular purpose and constitutes the only warranty made by ROBOT-COUPE U.S.A., INC.

IMPORTANT WARNING

 WARNING
Keep these instructions in a safe place

WARNING: In order to limit accidents such as electric shocks or personal injury, and in order to limit material damage due to misuse of the appliance, please read these instructions carefully and follow them strictly. Reading the operating instructions will help you get to know your appliance and enable you to use the equipment correctly. Please read these instructions in their entirety and make sure that anyone else who may use the appliance also reads them beforehand.

UNPACKING

- Carefully remove the equipment from the packaging and take out all the boxes or packets containing attachments or specific items.
- **WARNING** - some of the tools are very sharp e.g. blades, discs... etc.
- Store manuals, tools and spare parts in a safe place available to the users of the machine.

INSTALLATION

- Install the machine on a clear floor space with sufficient room to safely operate and clean the machine.

CONNECTION

- Always check that your power supply corresponds to that indicated on the identification plate on the motor unit and that it can withstand the amperage.
- The machine must be grounded.
- Always check that the motor shaft rotates in anticlockwise direction before the blades are installed.

HANDLING

- Always take care when handling the blades, as they are extremely sharp.
- Wear cut-proof gloves when handling the blades.

ASSEMBLY PROCEDURES

- Follow the various assembly procedures carefully (see page 6) and make sure that all the attachments are correctly positioned.

USE

- Never try to override the locking and safety systems.
- Never insert any object into the container where the food is being processed.
- Never push the ingredients down with your hand.
- Do not overload the appliance.
- Maximum fill level is $\frac{2}{3}$ full, less if the product is very dense or sticky.

CLEANING

- As a precaution, always unplug your appliance before cleaning it.
- Always clean the appliance and its attachments at the end of each cycle.
- Never immerse the motor unit in water.
- For parts made from aluminum, use metal safe detergents intended for aluminum.

- Caustic detergents used in automatic dishwashers quickly degrade plastic parts. Hand wash plastic parts if possible.
- Robot-Coupe can in no way be held responsible for the user's failure to follow the basic rules of cleaning and hygiene.

MAINTENANCE

- Do not open the motor housing. There are no user serviceable components inside the electrical housing. Refer control component repairs to qualified technicians.
- Remove and clean shaft seals monthly. Replace seals each 3 to 6 months. Lubricate with food safe grease.
- It is particularly important to maintain and check the attachments since certain ingredients contain corrosive agents, e.g. citric acid.
- Never operate the appliance if the power cord or plug has been damaged or if the appliance fails to work properly or has been damaged in any way.
- If the machine malfunctions in any way discard any food being processed and refer service to qualified maintenance technicians.

INTRODUCTION TO YOUR NEW R 8 • R 10 • R 15 • R 20 CUTTER MIXER

The Cutter is perfectly geared to professional requirements. It will perform any number of tasks, as you will discover with use.

It can be used for processing meat and vegetables, fine stuffing, mousse, grinding, kneading and mixing,... all in seconds. Its outstanding results will soon introduce you to a whole new world of culinary skills.

Its simple design means that all parts which are handled frequently can be easily assembled, or removed for maintenance or cleaning.

To make things easier for you, this instructions manual has been divided according to the various assembly operations.

This manual contains vital information designed to help the user get the most out of his or her cutter mixer.

Consequently, we strongly advise you to read the manual carefully before using your machine. We have also included a few examples to help you get the feel of your new machine and appreciate its countless advantages.

SWITCHING ON THE MACHINE



WARNING

THIS APPLIANCE MUST BE PLUGGED INTO AN GROUNDED SOCKET (RISK OF ELECTROCUTION).

• ADVICE ON ELECTRICAL CONNECTION

Before plugging in, check that your power supply corresponds to that indicated on the machine rating plate.

Three phase R 8 • R 10 • R 15 • R 20

These models must be powered from a 220 V / 60 Hz / 3 phase electrical supply.

The machine is supplied with a power cord and a plug attachment. If wiring to a service disconnect box, this should be undertaken by a qualified electrician.





The power cord has four wires, one grounded wire, plus three phase wires.

Connect the green wire to the ground terminal pin.

These machines do not require a neutral connection.

• CONTROL PANEL

R 8 • R 10 • R 15 • R 20 :

- Red button  = "Off"
- Green button I  = "On" Low speed
- Green button II  = "On" High speed
- Black button  = pulse control
- Green indicator  = Machine status indicator

ASSEMBLY

• MACHINE



1) With the motor base facing you, position the bowl on the motor shaft so that the handle on your left is near the control panel.

2) Pressing down on the handles, turn the bowl firmly in an anticlockwise direction until it locks into place.



3) Position the blade mounted on the motor shaft. Then rotate it so that it is lowered right down to the bottom of the bowl.

Always check that the blade is correctly positioned at the **bottom of the bowl** before adding the ingredients to be processed.

• If the lid parts are already assembled:

4) Place the lid assembly in the correct position. Next, insert the metal pin as far as it will go.



• If the lid parts have not been assembled:

4) Position the end of the lid arm in the hinge. Next, insert the metal pin as far as it will go (photo ①). Push the lid guide through the lid arm hole and screw the cone into the top of the guide (photo ②). Clip the lid onto the guide and turn it so that the dimples are beneath the lid arm (photo ③).



5) Close the lid by securing the locking hook to the edge of the bowl and pushing the handle down.

The machine is now ready for operation.

The green indicator light should be on.

⚠ WARNING

There is a green status indicator light on the control panel of the motor unit. If this green light does not come on, consult the relevant paragraph. A flashing green light means that the conditions for the operation have not all been met. Check that the bowl, lid arm and lid are all correctly positioned. As soon as the light stops flashing and stays on, you can use your machine.

• **BLADE** (see diagram, page 13)

For fine stuffing, mousse and emulsions, use the smooth blades.

There should not be any spacer between the base of the blade support and the lower blade.

You must always insert the small spacer between the blade support base and the lower blade (regular base assembly) before carrying out mincing tasks. In order to control the mincing process and prevent the meat from overheating, always use the «pulse» button (coarse mincing assembly).

For grinding or kneading, use serrated blades and do not fit any spacer between the lower blade and the blade support base.

Use fine serrated blades to chop parsley and do not insert any spacer between the blade support base and the lower blade.

USES AND EXAMPLE

USES	Max processing quantity (in pounds)				Speed
	R 8	R 10	R 15	R 20	
CHOP					
• MEAT					
Hamburger/ steak tartare	6 5/8	8 3/4	13 3/16	17 5/8	Low
Sausage meat / tomatoes	6 5/8	8 3/4	13 3/16	17 5/8	Low
Terrine / pâté	4 3/8	8 3/4	17 5/8	22	Low
White pudding / liver mousse	8 3/4	11	19 7/8	24 1/4	High
Galantine (stuffing + thin slices)	4 3/8	6 5/8	17 5/8	22	High
• FISH					
Brandade / quenelle	8 3/4	11	15 7/16	19 7/8	High
Terrines	8 3/4	11	19 7/8	24 1/4	High
• VEGETABLES					
Garlic / parsley / onion / shallots	2 1/4 to 6 5/8	2 1/4 to 6 5/8	4 3/8 to 11	4 3/8 to 13 3/16	High
Soup / vegetable purées	8 3/4	11	19 7/8	24 1/4	Low
• FRUIT					
Compotes / fruit purée	8 3/4	11	19 7/8	24 1/4	Low
EMULSIFY					
Mayonnaise / ašloli	8 3/4	11	19 7/8	24 1/4	High
Rémoulade sauce	8 3/4	11	19 7/8	24 1/4	Low
Snaš / salmon butter	4 3/8	6 5/8	11	15 7/16	Low
KNEAD					
Shortcrust pastry / shortbread	8 3/4	11	15 7/16	19 7/8	High
Flaky pastry	8 3/4	11	15 7/16	19 7/8	Low
Brúče + Raisin dough	8 3/4	11	15 7/16	19 7/8	Low
GRIND					
Almond paste / nuts	4 3/8	6 5/8	11	13 3/16	Low
Seafood / ice cubes	4 3/8	6 5/8	13 3/16	17 5/8	Low
Breadcrumbs	4 3/8	6 5/8	11	13 3/16	Low

The cutter-mixer has numerous other applications; the above examples are given for guidance and may vary according to the quality of ingredients or recipes.

OPERATION

Because of the special bowl and blade design of the Robot Coupe Vertical Cutter Mixers, most operations

are completed in a matter of seconds. The operator should pay close attention to the product as well as the amount of time required to process. Operations should be run on Low speed, using High speed only when an extremely fine puree consistency is desired. There are two ways to run your unit. First of all, you may run the unit continuously by filling the bowl with food and simply letting it run until the desired consistency has been reached. Use this method to grind, mix, blend, puree, or emulsify. Secondly, you may chop with your unit by pulsing the machine. Cut round products into halves or quarters and prep long vegetables into 3 to 4 inch pieces. Place these into the bowl, and using Low speed, pulse the unit on and off quickly. Usually 4 to 5 pulses yields an evenly mixed chopped substance.

TO CHOP

To achieve a chopped consistency for vegetables, cheese, meats, etc. fill the bowl with the product no more than $\frac{3}{4}$ full, or as low as two to three onions. Small batches would require lowering the top cutting blade. With the lid secured, and the speed selector in Low speed, press the pulse function quickly then release. Repeat this pulsing action, allowing the blade to stop each time, until the desired cut is achieved.

TO PUREE OR MIX

Fill the bowl with the product no more than $\frac{3}{4}$ full. Start the machine in Low speed and allow to run until the product is completely reduced. If necessary, turn the machine off and select High speed to finish the product. It may be necessary to add some liquids to a puree to achieve the desired consistency. If a complete homogeneous mixture is required for analytical testing, it may be required to scrape the walls of the bowl one time during processing to complete the homogeneous mixture.

DOUGHS AND PASTRIES

Prepare doughs and pastries on Low speed only. In many cases it may be helpful to first mix all dry products then add the liquids. The unit should

be run continuously until the product is completely processed. For thick doughs, such as for pizza, the machine will form a ball of dough when the mixing is complete. When a bowl is formed the machine should be turned off immediately to prevent over processing. Preparation times and all ingredients should be noted for different recipes.

As an example: detailed process for bread dough

- The blade assembly must be set-up with two blades only.
- Do not use the lid wiper / bowl scraper.
- Mix all ingredients except water and salt for 15 seconds on low speed,
- Stop the unit, open the lid and add water and salt (needs about 20 seconds),
- Knead for 35 seconds on low speed*. Stop immediately the machine when the ball is formed to avoid any overheating of the dough.

* Approximate duration: to set according to your own recipe.

OPTIONS

• STAINLESS-STEEL MINI BOWL

Optional extra: 3.5-litre mini bowl for the R 8 and 4-litre mini bowl for the R 10 and R 15, plus 100% stainless steel blade assembly, easily taken apart, for making quick sauces, chopping herbs and carrying out all those other last-minute tasks or small batches.

• STAINLESS-STEEL MINI BOWL WITH 3.5-LITRE CAPACITY FOR R 8 AND 4-LITRE CAPACITY FOR R 10 • R 15



1) Place the mini bowl over the chimney of the large bowl, then turn it until it fits into position over the lug. The mini bowl handles should now be lined up with those of the large bowl.

2) Next, slot the 100% stainless-steel blade assembly over the motor shaft and place the mini lid on top of the mini bowl to avoid splashing. Next, close the machine lid.



• SERRATED BLADE - FINE SERRATED BLADE

The blade support can be fitted either with two coarse serrated blades or with two fine serrated blades.

The serrated blades are mainly used :

- for making pastry
- for grinding.

The fine serrated blades are mainly used for:

- chopping parsley
- blending

• VACUUM KIT R-VAC®

Your cutter can perform vacuum processing without any need for modifications.

Simply assemble the vacuum kit R-VAC®, patented by ROBOT-COUCPE on to the lid and connect it to a vacuum pump (see instructions page 10).

If you already have a vacuum packing machine, you can connect the kit to the vacuum pump on this machine.

Robot Coupe does not market vacuum pumps. The R-VAC® kit was specifically designed so that liquids can be added to the mixture during processing, while keeping the food under vacuum.

CLEANING



WARNING

As a precaution, always unplug your appliance before cleaning it (hazard of electrocution) and handle the blades with care (hazard of injury).

When the machine has completed its task, open the lid by releasing the locking handle.

Press down firmly on the handles, unlock the bowl by turning it in a clockwise direction, then pull it upwards to free it.

If the food has a solid consistency, remove the blade assembly by grasping blade knob to remove the blade then empty the bowl.

CAUTION CUT HAZZARD

Always use spatula or scraper to remove food from the blades, never use bare hands.

To remove food residue from the blades, put the bowl back, slot the blade assembly back over the motor shaft, and run the machine at high speed. Similarly, for precleaning, pour a couple of litres of hot water into the bowl and run the machine for a few seconds at high speed.

The machine can be washed with a kitchen spray (though not with a power washer).

! IMPORTANT

Like the bowl and lid, the blade assembly should also be removed for cleaning after use.

Always allow all metal parts, especially knives, to dry completely on a plastic rack before assembling components for storage to avoid corrosion.

After cleaning the blade assembly, always completely dry the blades to prevent rusting or air dry metal parts on a plastic rack before assembling the blade for overnight storage.

When the machine is not in use, turn off at service disconnect or disconnect from the power supply and leave the lid open.

Never immerse the motor base in water. Clean using a damp cloth or sponge.



IMPORTANT

Check that your detergent is suitable for cleaning the plastic parts.

Certain washing agents are too alkaline (e.g. high levels of caustic soda or ammonia) will rapidly deteriorate plastic parts.

MAINTENANCE

• DISMANTLING THE BLADE ASSEMBLY

1) R 8 • R 10 • R 15 • R 20 blade

- Disconnect the machine power cord.
- Remove the bowl.
- Position the blade dismantling tool on the motor shaft.

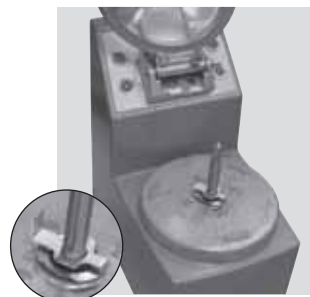

- Slide the blade assembly right down the motorshaft.
- Make sure that the lower blade is resting on top of the blade dismantling tool.



- Loosen the locking nut with the special wrench.



- To reassemble the blade assembly, simply do the same in reverse order.

2) 3.5- or 4-litre mini bowl blade assembly.

A special tool is supplied with the machine to disassemble the mini bowl blade assembly.



• BLADES

We strongly recommend that the blades (smooth ones) are sharpened daily, using the sharpening stone supplied with the machine.

The quality of the cut depends mainly on the sharpness of your blades and the degree of wear. The blades are actually wearing parts, which should be replaced occasionally to ensure consistent quality in the final product.

• SEAL

The seal on the motorshaft should be lubricated regularly using a food safe lubricant.

In order to keep the motor completely watertight, it is advisable to check the gasket monthly for wear and tear and replace if necessary.

Replace shaft seals each 3 to 6 months. Lubricate seals with food grade grease.

• LID SEAL

The lid is designed to be completely watertight. In order to ensure that it remains that way, you may have to change the seal occasionally, depending on how regularly you use your machine.

If you do not use your machine regularly, between uses it is advisable to leave the lid open to preserve the lid seal original characteristics.

OPERATING INSTRUCTIONS FOR THE VACUUM KIT R-VAC®

1° ASSEMBLING THE VACUUM KIT R-VAC®

- Insert filter N° 2 into body N° 3
- Screw part N° 1 onto body N° 3 (the tube is fed through body N° 3).

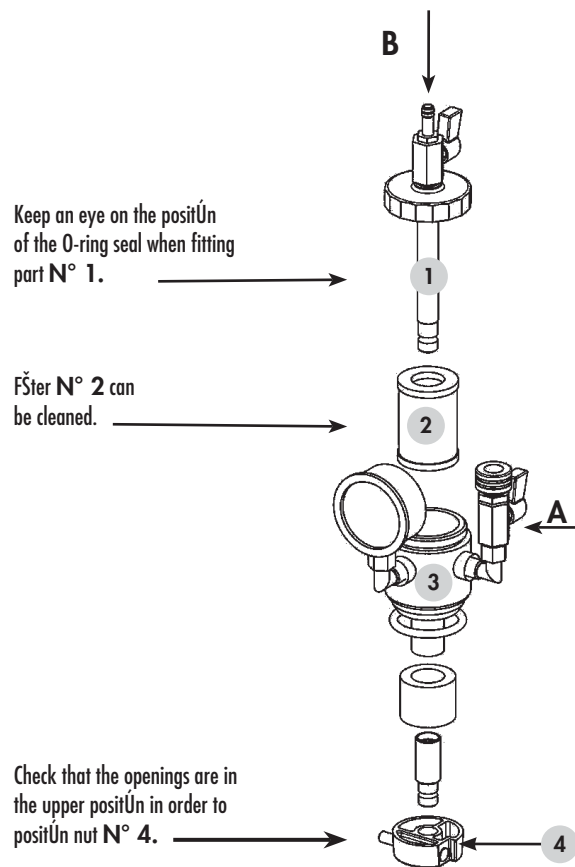

4° USING THE VACUUM KIT R-VAC®

- Connect up the vacuum pump to valve A, check that the latter is open (lever in shaft of connector).
- Shut valve B (perpendicular lever).

2° PLACING THE VACUUM KIT R-VAC® ON THE LID

- Insert the vacuum kit into the cone section of the plastic part N° 5. The latter should be screwed into the lid guide N° 6 which, in turn, should be slotted into the aluminium lid arm N° 8. The lid N° 9 should also be clipped onto the lid guide N° 6.

3° CLIPPING THE RETAINER N° 4

- Hold the retainer in the palm of your hand and press the pusher N° 7 in with your thumb.
- Fit the nut onto the cylindrical section which juts out over the lid.
- Release button N° 7.
- The pusher should return to its extended locked position. If it does not, press the retainer gently so that it automatically clicks into place.
- Check that the retainer is properly attached to the tube N° 1, in order to avoid all risk of the bell or kit falling off.

5° ADDING LIQUID TO THE MIXTURE

- Attach a tube to valve B.
- Immerse the other end of this tube in the liquid to be added.
- Open valve B slowly ; once the liquid has been added, shut valve B.

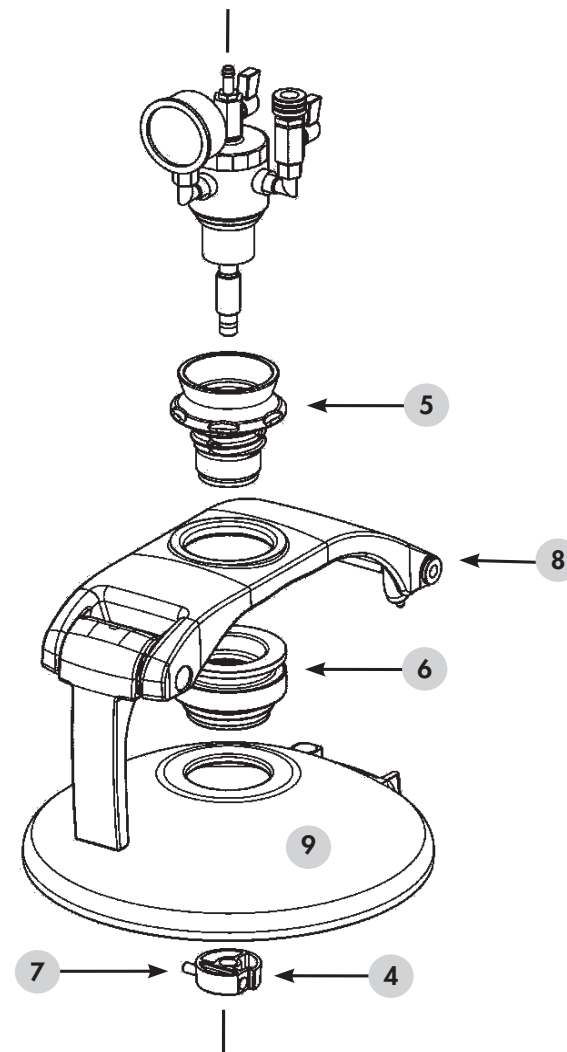

NOTE

Follow operating instructions as provided by the manufacturer of your vacuum pump

DIAGNOSTIC SYSTEM



REMEMBER

The control system requires the lid be opened and closed, once after switching your appliance on.

This sequence will check the correct operation of the lid arm safety switch. At this stage, if all the conditions are met for operation, the light will stop flashing and stay on.

Your appliance is equipped with a green light that indicates the operational status of your machine:

- **no light**: see paragraph 1.
- **flashing light**: see paragraph 2.
- **steady light**: your appliance is ready to run.

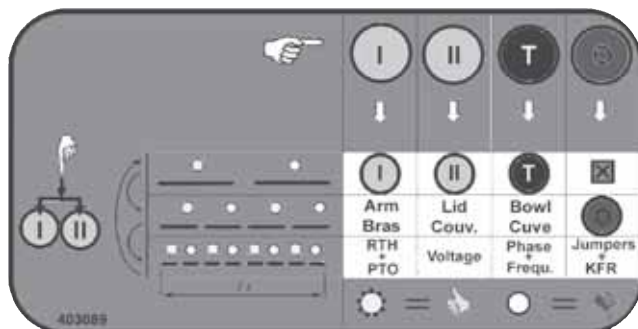

REMEMBER

Always switch your machine off before carrying out any cleaning or maintenance.

All repair and maintenance work must be carried out by a qualified technician.

1) No light

This means that either your appliance is switched off or there is a problem with the power supply.

Measure the voltage at the power outlet and check that the plug is correctly wired.

If the problem persists, the control board must be replaced.

2) Flashing light

One or more of the safety devices or thermal protectors is not responding properly.

These safety devices comprise 3 presence sensors, a thermal relay and a motor overload protector.

The status light and the control buttons offer a means of testing the machine's components and safety devices before performing any service operation.

There is no point continuing with the test once you have detected a fault. Instead, rectify the problem first and start the test afresh.

• General points:

The previous table helps you following the test procedure.

It identifies the device that can be tested as follow :

Each of the 4 columns corresponds to one of the 4 buttons, pressed one after the other by the operator.

The 3 rows correspond to the 3 successive test levels.

You can change the level by simultaneously pressing **buttons I and II**. Each level is identified by the flashing speed of the light: slow for level one, fast for level two and very fast for level three. To return to testing level 1, the **buttons I and II** must be simultaneously pressed a further time.

When none of the buttons is being pressed, the light flashes to indicate the current testing level.

When one of the buttons is continuously pressed, it indicates the actual status of the corresponding device : on = OK, off = problem.

• Test sequence:

When the green light flashes, start by pressing **button I** to test that it is working properly (similarly, test **button II** and then test **button T**).

At this level, **button O** can not be tested yet.

Press **buttons I and II** simultaneously to move up to testing level 2, indicated by more rapid flashing speed of the indicator light.

At level 2, **buttons I, II, T and O** allow to test the presence sensors of the lid, the base and the bowl, and **button O**, respectively.

Press **buttons I and II** simultaneously to move up to testing level 3, indicated by very rapid flashing speed of the indicator light.

At level 3, **buttons I, II, T and O** allow to test the thermal relay + the motor thermal protector, the mains voltage, the phase-frequency detector, and the configuration jumpers + braking relay, respectively.

Press **buttons I and II** simultaneously to return to the normal flashing speed and therefore to testing level 1.

• Checks

- If the test sequence reveals a button default, check first the button's contact block operation and its wiring.

- If the test sequence reveals a problem with one of the presence sensors, check that the removable parts of your cutter mixer (bowl, lid and arm) are all in place. If the problem persists, check the presence sensors themselves and their wiring.

- If the test sequence indicates that the thermal relay is faulty, check it is correctly set (automatic position and current setting in accordance with the electrical diagram);
- If the test indicates that the motor overload protector is faulty, check its wiring;
- If a «voltage» or «Phase + Frequ» error is detected, check that the machine is supplied with the correct voltage. Also check that the plug attachment is correctly wired.
- If a «Jumpers + KFR» error message is detected, check that the configuration jumpers on the control board are set according to the electrical diagram.

FITTING AND USING THE BLADE ASSEMBLY



Screw nut



Plastic ring

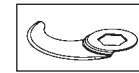

Blade



Long ring



Narrow spacer



Blade support

• 2-BLADE ASSEMBLY:

We recommend you use the two-blade assembly for processing small amounts (less than half the maximum capacity indicated on page 7).

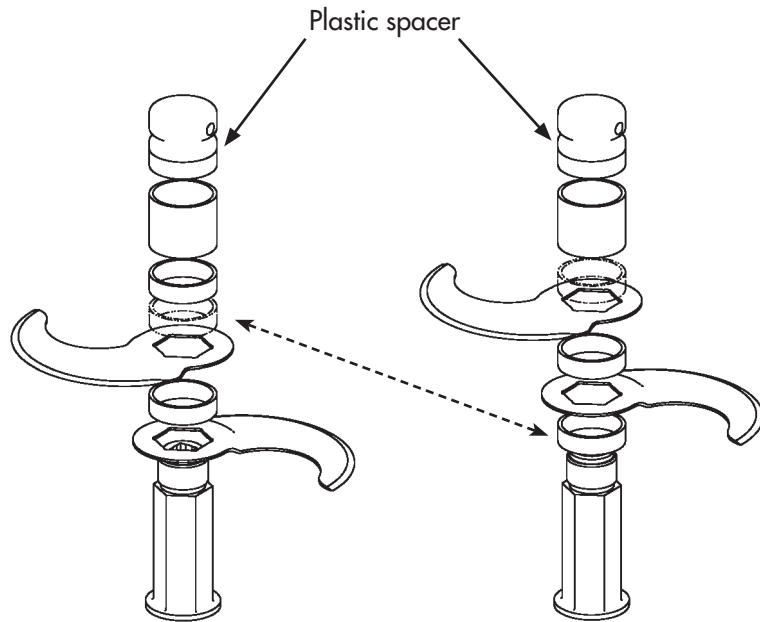

Position 1

Regular blade assembly

Position 2

Coarse mincing assembly

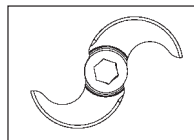

Correct positioning
of 2-blade assembly
(top view)

• 3-BLADE ASSEMBLY:

We recommend you use the 3-blade assembly for processing large quantities of more than half the maximum limit indicated, with the exception of liquid or blended preparations for which we strongly recommend you use the 2-blade assembly. **For preparations of this kind, it is recommended using the low speed in order to obtain the best results.**

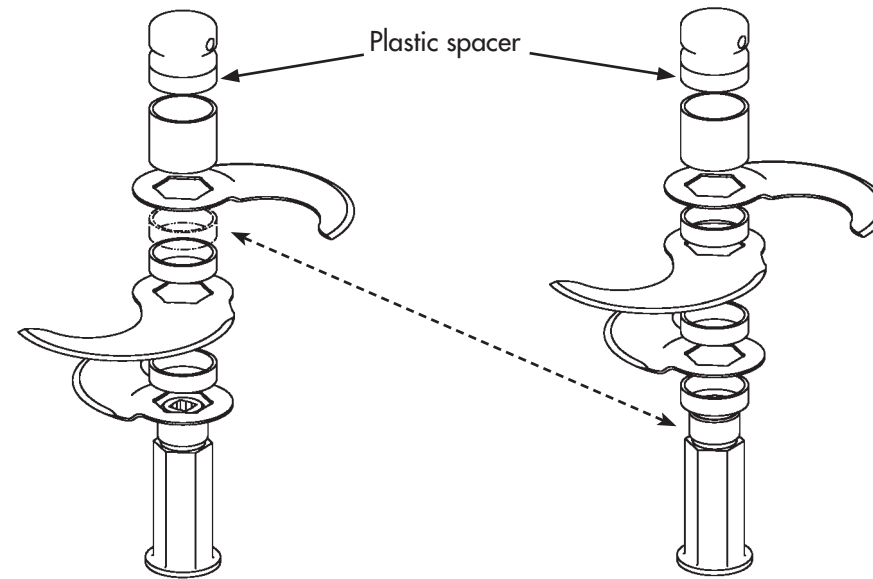

Position 1

Regular blade assembly

Position 2

Coarse mincing assembly

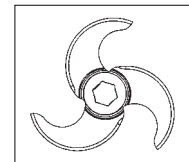

Correct positioning
of 3-blade assembly
(top view)

POSITION 1: No spacer between lower blade and blade support.

- For **fine chopping** and **emulsions**.
- For **grinding** and **kneading**.

POSITION 2: With spacer between lower blade and blade support.

- For **coarse chopping**

DISMANTLING:

- Unscrew the screw nut.
- Remove the rings and blades.

ASSEMBLING:

- Fit the blades and spacers so that they are the right distance apart, according to the:
 - type
 - weight and
 - volume of the foodstuffs to be processed.

WARNING: The plastic ring must be placed immediately under the locking nut.

TECHNICAL SPECIFICATIONS

• WEIGHT & DIMENSIONS

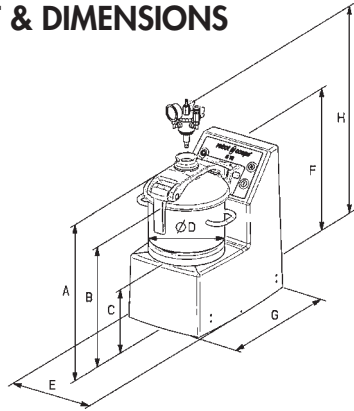

Models	Dimensions (in inches)								Weight (Lb)	
	A	B	C	D	E	F	G	H	Net	Gross
R 8	23	17 ½	10	11 13/16	12 3/8	20 11/16	21 7/16	34 5/8	93	52
R 10	26	20 ½	11	11 13/16	13 9/16	23 5/8	22 1/16	39	126	57
R 15	26 ¾	21 ¼	11 13/16	13 3/8	14 9/16	24 3/8	24 ¼	42 ½	137	62
R 20	30	24	12 ¾	12 ¾	14 15/16	27 9/16	24 7/8	65	194	88
Vacuum kit R-vac®									2.20	
Vacuum pump									61.7	

• WORKING SPACE

Place the machine in a clear floor space sufficiently large for the operator to use and clean the machine safely.

• NOISE LEVEL

The equivalent continuous sound level when the machine is operating on no-load is less than 70 dB (A).

• ELECTRICAL DATA

Models	Motor	Low speed (rpm)	High speed (rpm)	Output power (Watts)	Rated current (Amp.)
R 8	220V / 60 Hz - 3	1800	3600	1500	9.9
R 10	220V / 60 Hz - 3	1800	3600	1800	11.8
R 15	220V / 60 Hz - 3	1800	3600	2100	17.8
R 20	220V / 60 Hz - 3	1800	3600	3300	21.3

SAFETY



WARNING

The blades are extremely sharp. Handle with care. Wear cut resistant gloves when handling the blades.

This **ROBOT-COUPÉ** range of cutter mixers is equipped with a electro-mechanical safety system and a motor brake. Moreover, the machine will not operate unless the bowl and lid are correctly positioned on the motor base.

The motor stops as soon as the lid is opened. However, when processing liquid ingredients, the user must stop the machine before opening the lid, to avoid splashing.

This is very important especially with hot ingredients.

To restart the machine, simply close the lid and press the low or high speed button.

These models are fitted:

- with a **thermal relay that stops the machine when it is overloaded**. The thermal relay resets itself automatically after a few tens of seconds.

- a thermal protector insterted in the motor winding that stops the machine if the motor temperature rises above the maximum limit. It his happens, allow the machine to cool down for several minutes (about 10 to 20 minutes) before attempting to restart it.



REMEMBER

Never try to override the locking and safety systems.

Never insert an object into the container where the food is being processed.

Never push the ingredients down with your hand.

Do not overload the appliance.

Never switch the appliance on when it is empty.

SERVICE

See warranty first then;

Should your unit require service, check online at www.robotcoupeusa.com to find the nearest Robot Coupe Authorized Service Agency or call the factory to see where local service is available.

If you wish your unit to be serviced at the factory, call for return instructions and ship the unit prepaid to our factory address.

PH : 1-800-824-1646

Robot-Coupe USA, Inc
Service Department Repair
264 South Perkins Street
Ridgeland, MS 39157

For service in Canada contact the Robot-Coupe USA factory for repair instructions.

robot  ***coupe***®

TECHNICAL DATA

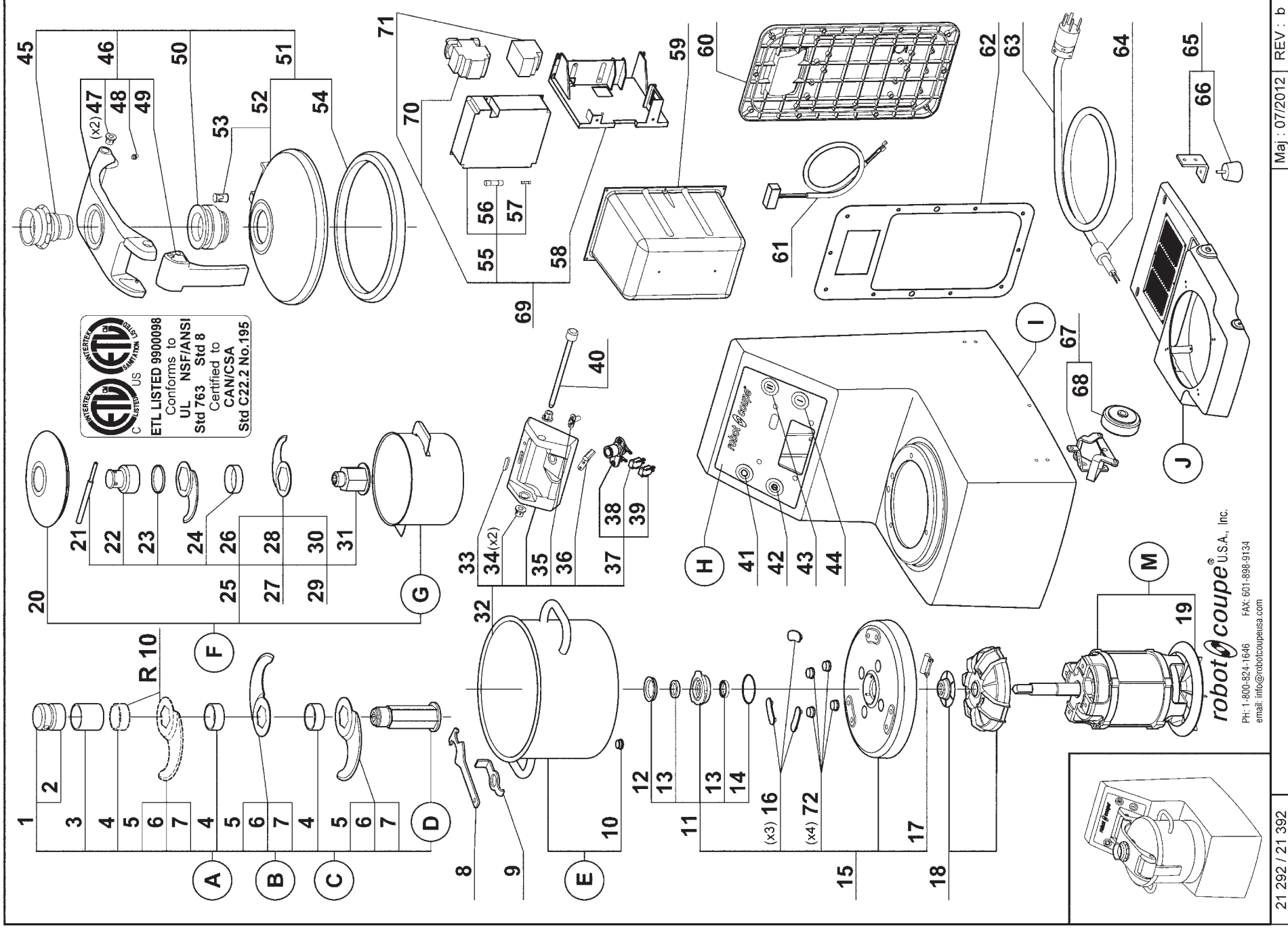

robotcoupe® U.S.A., Inc.

PH: 1-800-824-1646

FAX: 601-898-9134

email: info@robotcoupeusa.com

Index	Pièce / Part	Désignation	Description
1	59 278	ECROU DE COUTEAU	BLADE LOCKING NUT
2	59 279	BAGUE COUTEAU PLASTIQUE 15 MM	PLASTIC RING 15 MM
3	117 225S	BAGUE INOX 45 MM	STAINLESS STEEL 45 MM RING
4	100 792S	BAGUE INOX 15 MM	STAINLESS STEEL 15 MM RING
5	59 280	LAME LISSE	STRAIGHT BALDE
6	59 281	LAME CRANTÉE	COARSE SERRATED BLADE
7	59 282	LAME DENTÉE	FINE SERRATED BLADE
8	119 200S	CLEF DEMONTE COUTEAU	KNIFE WRENCH
9	59 291	DEMONTE COUTEAU	KNIFE TOOL
10	59 292	AIMANT CUVE	BOWL MAGNET
11	59 293	DOUILLE PORTE JOINTS	SEALING SOCKET
12	500 901S	JOINT V RING	V RING
13	501 624S	BAGUE ETANCHEITE	O RING
14	502 670S	JOINT TORIQUE	MOTOR SUPPORT
15	59 294	SUPPORT MOTEUR	BOWL REST (X3)
16	59 299	APPUI CUVE (X3)	BOWL SECURITY
17	59 300	SECURITE CUVE	DEFLECTOR AND WATER PROTECTOR
18	59 310	DÉFLECTEUR ET GUIDE D'EAU	MOTOR FAN
19	59 311	VENTILATEUR	MINI BOWL LID
20	59 457	COUVERCLE MINI CUVE	MINI BOWL BLADE TOOL
21	101 845S	CLEF COUTEAU MINI CUVE	MINI BLADE ASSY KNOB
22	101 804S	ECROU COUT MINI CUVE	MINI BOWL 4 MM SPACER
23	101 846S	RONDELLE E4 COUT MINI CUVE	MINI BOWL 15 MM SPACER
24	101 806S	BAGUE 15 MM MINI CUVE	MINI BOWL STRAIGHT BLADE ASSY
25	59 458	COUTEAU MINI CUVE	MINI BOWL STRAIGHT BLADE
26	101 800S	LAME LISSE MINI CUVE	MINI BOWL F SERRATED BLADE ASSY
27	59 460	COUTEAU DENTE MINI CUVE	MINI BOWL FINE SERRATED BLADE
28	59 436	LAME DENTEE MINI CUVE	MINI BOWL C SERRATED BLADE ASSY
29	59 459	COUTEAU CRANTE MINI CUVE	MINI BOWL COARSE SERRATED BLADE
30	101 801S	LAME CRANTEE MINI CUVE	MINI BOWL KNIFE ASSY SUPPORT
31	101 802S	SUPPORT MINI COUTEAU	HINGE ASSEMBLY
32	59 328	ENS CHARNIERE	LID ARM REST
33	59 329	BUTÉE DE BRAS	CENTERING WASHER
34	59 315	DOUILLE DE CENTRAGE	LIGHT
35	59 330	VOYANT	LID SECURITY
36	59 331	SÉCURITÉ COUVERCLE	LID SUPPORT SECURITY
37	59 332	SECURITÉ DE BRAS	SECURITY SWITCH
38	501 258S	INTERRUPTEUR SECURITE	SECURITY SWITCH
39	507 250S	INTERRUPTEUR SECURITE	HINGE PIN
40	59 333	AXE CHARNIERE	STOP BUTON
41	59 484	BOUTON ARRÊT	PULSE BUTON
42	59 487	BOUTON PULSE	II BUTON
43	59 486	BOUTON II	I BUTON
44	59 485	BOUTON I	LID FUNNEL
45	59 313	CONE DE COUVERCLE	LID ARM ASSEMBLY
46	59 314	ENS BRAS DE COUVERCLE	CENTERING WASHER
47	59 315	DOUILLE DE CENTRAGE	SECURITY PISTON
48	59 316	DOIGT DE SÉCRUITÉ	LID HANDLE ASSEMBLY
49	59 317	ENSEMBLE POIGNÉE	LID GUIDE
50	59 318	APPUI DE COUVERCLE	LID ASSEMBLY
51	59 319	ENSEMBLE COUVERCLE	LID
52	59 320	COUVERCLE	LID MAGNET ASSEMBLY
53	59 321	ENSEMBLE AIMANT COUVERCLE	LID GASKET
54	59 322	JOINT DE COUVERCLE	PCB
55	59 335	CARTE DE COMMANDE	10X38 FUSE
56	502 495S	FUSIBLE 10X38	5X20 FUSE
57	502 442S	FUSIBLE 5X20	SUPPORT
58	59 339	SUPPORT CARTE	PCB PROTECTION
59	59 337	PROTECTION CARTE	FLAP DOOR
60	59 338	TRAPPE	CONNECTION WIRES
61	59 336	FAISCEAU DE CONNEXION	FLAP DOOR SEAL
62	59 340	JOINT TRAPPE ACCES	POWER CORD
63	59 428	CABLE ALIMENTATION	WIRE DUCK
64	59 489	PASSE-FIL	FOOT ASSEMBLY
65	59 342	PIED COMPLET	FOOT
66	100 790S	PIED	CASTOR ASSEMBLY
67	59 431	ENSEMBLE ROULETTE	CASTOR
68	59 432	ROULETTE	COMMAND ASSEMBLY
69	59 403	ENSEMBLE DE COMMANDE	CONTACTOR
70	59 490	CONTACTEUR	THERMAL RELAY
71	59 491	RELAIS THERMIQUE	MOTOR BOLT CUP KIT (X4)
72	59 453	ENSEMBLE CACHE-VIS (X4)	

Index	Désignation	Description
A	ENS COUTEAU LAMES LISSES	STRAIGHT BALDE ASSEMBLY
B	ENS COUTEAU LAMES CRANTÉES	COARSE SERRATED BLADE ASSEMBLY
C	ENS COUTEAU LAMES DENTÉES	FINE SERRATED BLADE ASSEMBLY
D	SUPPORT COUTEAU	BLADE SUPPORT
E	CUVE	BOWL
F	ENSEMBLE MINI CUVE	MINI BOWL ASSEMBLY
G	MINI CUVE	MINI BOWL
H	PLAQUE FRONTALE	FRONT PLATE
I	SOCLE	BASE ASSEMBLY
J	GUIDE D'AIR	AIR DEFLECTOR
M	MOTEUR	MOTOR
<hr/>		
Type	Machine	Voltage
	A	B
	C	D
	E	
R8	TOUTES ALL	27 381
		27 383
		27 385
		101 636S
		59 264
	Machine	F
		G
		H
		I
		J
- 593 - - - - -	TOUTES ALL	27 374
		59 430
		59 343
		59 344
		59 456
	Machine	M
		21 292
		208-240/60/3
		59 352
Type	Machine	Voltage
	A	B
	C	D
	E	
R10	TOUTES ALL	27 382
		27 384
		27 386
		101 967S
		59 265
	Machine	F
		G
		H
		I
		J
- 594 - - - - -	TOUTES ALL	27 375
		59 435
		59 353
		59 354
		59 434
	Machine	M
		21 392
		208-240/60/3
		59 358

robotcoupe® U.S.A., Inc.

R15E - R20E

Serial number : - 595 - - - - -13Y-MM
 Serial number : - 596 - - - - -13Y-MM

2 Speeds, 208-240 Volt, 3 Phases, 60Hz
 R15E 2.0/3.0 kW 1750/3480 RPM 17.8 Amps
 R20E 3.3/4.4 kW 1760/3500 RPM 21.3 Amps

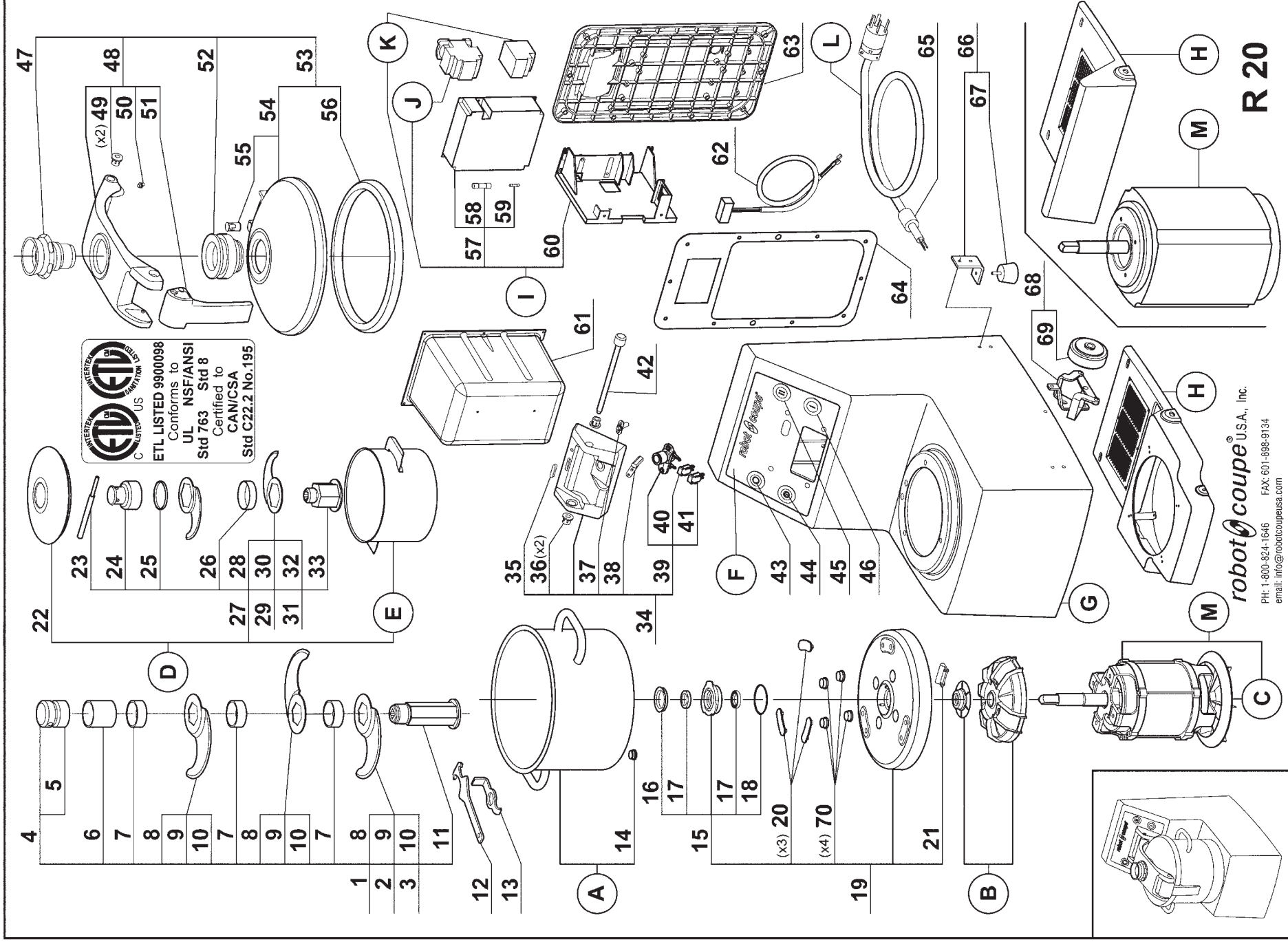

robotcoupe® U.S.A., Inc.

PH: 1-800-824-1646 FAX: 601-898-9134
 email: info@robotcoupeusa.com

R 20

51 492 / 51 592

Maj : 07/2012 REV : c

Index	Pièce / Part	Désignation	Description
1	57 097	ENS COUTEAU LAMES LISSES	STRAIGHT BALDE ASSEMBLY
2	57 098	ENS COUTEAU LAMES CRANTÉES	COARSE SERRATED BLADE ASSEMBLY
3	57 099	ENS COUTEAU LAMES DENTÉES	FINE SERRATED BLADE ASSEMBLY
4	59 278	ECROU DE COUTEAU	BLADE LOCKING NUT
5	59 279	BAGUE COUTEAU PLASTIQUE 15 MM	PLASTIC RING 15 MM
6	117 225S	BAGUE INOX 45 MM	STAINLESS STEEL 45 MM RING
7	100 792S	BAGUE INOX 15 MM	STAINLESS STEEL 15 MM RING
8	59 392	LAME LISSE	STRAIGHT BALDE
9	59 393	LAME CRANTÉE	COARSE SERRATED BLADE
10	59 359	LAME DENTÉE	FINE SERRATED BLADE
11	101 967S	SUPPORT COUTEAU	BLADE SUPPORT
12	119 200S	CLEF DEMONTE COUTEAU	KNIFE WRENCH
13	59 291	DEMONTE COUTEAU	KNIFE TOOL
14	59 292	AIMANT CUVE	BOWL MAGNET
15	59 293	DOUILLE PORTE JOINT	SEALING SOCKET
16	500 901S	JOINT V RING	V RING
17	501 624S	BAGUE ETANCHEITE	LIP SEAL
18	502 670S	JOINT TORIQUE	O RING
19	59 360	SUPPORT MOTEUR	MOTOR SUPPORT
20	59 299	APPUI CUVE (X3)	BOWL REST (X3)
21	59 300	SECURITE CUVE	BOWL SECURITY
22	59 457	COUVERCLE MINI CUVE	MINI BOWL LID
23	101 845S	CLEF COUTEAU MINI CUVE	MINI BOWL BLADE TOOL
24	101 804S	ECROU COUT MINI CUVE	MINI BOWL ASSY KNOB
25	101 846S	RONDELLE E4 COUT MINI CUVE	MINI BOWL 4MM SPACER
26	101 806S	BAGUE 15MM MINI CUVE	MINI BOWL 15MM SPACER
27	59 458	COUTEAU MINI CUVE	MINI BOWL STRAIGHT BLADE ASSY
28	101 800S	LAME LISSE MINI CUVE	MINI BOWL STRAIGHT BLADE
29	59 460	COUTEAU DENTE MINI CUVE	MINI BOWL F SERRATED BLADE ASSY
30	59 436	LAME DENTEE MINI CUVE	MINI BOWL FINE SERRATED BLADE
31	59 459	COUTEAU CRANTE MINI CUVE	MINI BOWL C SERRATED BLADE ASSY
32	101 801S	LAME CRANTEE MINI CUVE	MINI BOWL COARSE SERRATED BLADE
33	101 802S	SUPPORT MINI COUTEAU	MINI BOWL KNIFE ASSY SUPPORT
34	59 328	ENS CHARNIERE	HINGE ASSEMBLY
35	59 329	BUTÉE DE BRAS	LID ARM REST
36	59 315	DOUILLE DE CENTRAGE	CENTERING WASHER
37	59 330	VOYANT	LIGHT
38	59 331	SÉCURITÉ COUVERCLE	LID SECURITY
39	59 332	SECURITÉ DE BRAS	LID SUPPORT SECURITY
40	501 258S	INTERRUPTEUR SECURITE	SECURITY SWITCH
41	507 250S	INTERRUPTEUR SECURITE	SECURITY SWITCH
42	59 333	AXE CHARNIERE	HINGE PIN
43	59 484	BOUTON ARRÊT	STOP BUTON
44	59 487	BOUTON PULSE	PULSE BUTON
45	59 486	BOUTON II	II BUTON
46	59 485	BOUTON I	I BUTON
47	59 313	CONE DE COUVERCLE	LID FUNNEL
48	59 361	ENS BRAS DE COUVERCLE	LID ARM ASSEMBLY
49	59 315	DOUILLE DE CENTRAGE	CENTERING WASHER
50	59 316	DOIGT DE SÉCRITÉ	SECURITY PISTON
51	59 317	ENSEMBLE POIGNÉE	LID HANDLE ASSEMBLY
52	59 318	APPUI DE COUVERCLE	LID GUIDE
53	59 362	ENSEMBLE COUVERCLE	LID ASSEMBLY
54	59 363	COUVERCLE	LID
55	59 321	ENSEMBLE AIMANT COUVERCLE	LID MAGNET ASSEMBLY
56	59 364	JOINT DE COUVERCLE	LID GASKET
57	59 335	CARTE DE COMMANDE	PCB
58	502 495S	FUSIBLE 10X38	10X38 FUSE
59	502 442S	FUSIBLE 5X20	5X20 FUSE
60	59 339	SUPPORT CARTE	PCB SUPPORT
61	59 337	PROTECTION CARTE	PCB PROTECTION
62	59 336	FAISCEAU DE CONNEXION	CONNECTION WIRES
63	59 338	TRAPPE	FLAP DOOR
64	59 340	JOINT TRAPPE ACCES	FLAP DOOR SEAL
65	59 489	PASSE-FIL	WIRE DUCK
66	59 342	PIED COMPLET	FOOT ASSEMBLY
67	100 790S	PIED	FOOT
68	59 365	ENSEMBLE ROULETTE	CASTOR ASSEMBLY
69	500 551S	ROULETTE	CASTOR
70	59 453	ENSEMBLE CACHE-VIS (X4)	MOTOR BOLT CUP KIT (X4)

Index	Désignation	Description
A	CUVE	BOWL
B	DEFLECTEUR ET GUIDE D'EAU	DEFLECTOR AND WATER PROTECTION
C	VENTILATEUR	MOTOR FAN
D	ENSEMBLE MINI CUVE	MINI BOWL ASSY
E	MINI CUVE	MINIBOWL
F	PLAQUE FRONTALE	FRONT PLATE
G	SOCLE	BASE ASSEMBLY
H	GUIDE D'AIR	AIR DEFLECTOR
I	ENSEMBLE DE COMMANDE	COMMAND ASSEMBLY
J	CONTACTEUR	CONTACTOR
K	RELAIS THERMIQUE	THERMAL RELAY
L	CABLE ALIMENTATION	POWER CORD
M	MOTEUR	MOTOR
<hr/>		
Type	Machine	Voltage
	TOUTES ALL	TOUS ALL
		A
		B
		C
		D
		E
		59 266
		59 310
		59 311
		27 375
		59 435
R15	Machine	Voltage
	TOUTES ALL	TOUS ALL
		F
		G
		H
		59 366
		59 368
		59 454
	Machine	Voltage
	51 492	208-240/60/3
		I
		J
		K
		L
		59 429
		59 491
		59 490
		59 429
		59 371
Type	Machine	Voltage
	TOUTES ALL	TOUS ALL
		A
		B
		C
		D
		E
		59 267
		-
		-
R20	Machine	Voltage
	TOUTES ALL	TOUS ALL
		F
		G
		H
		59 372
		59 373
		59 374
	Machine	Voltage
	51 592	208-240/60/3
		I
		J
		K
		L
		59 441
		59 380
		59 376
		59 441
		59 379

R8E - R10E - R15E - R20E

200V/50-60Hz - 220V/60Hz - 230V/50Hz - 380V/60Hz - 400V/50Hz

SCHEMA ELECTRIQUE

BLIXER®8E - BLIXER®10E - BLIXER®15E - BLIXER®20E

ELECTRIC DIAGRAM

ELEKTRISCHES SCHALTBILD

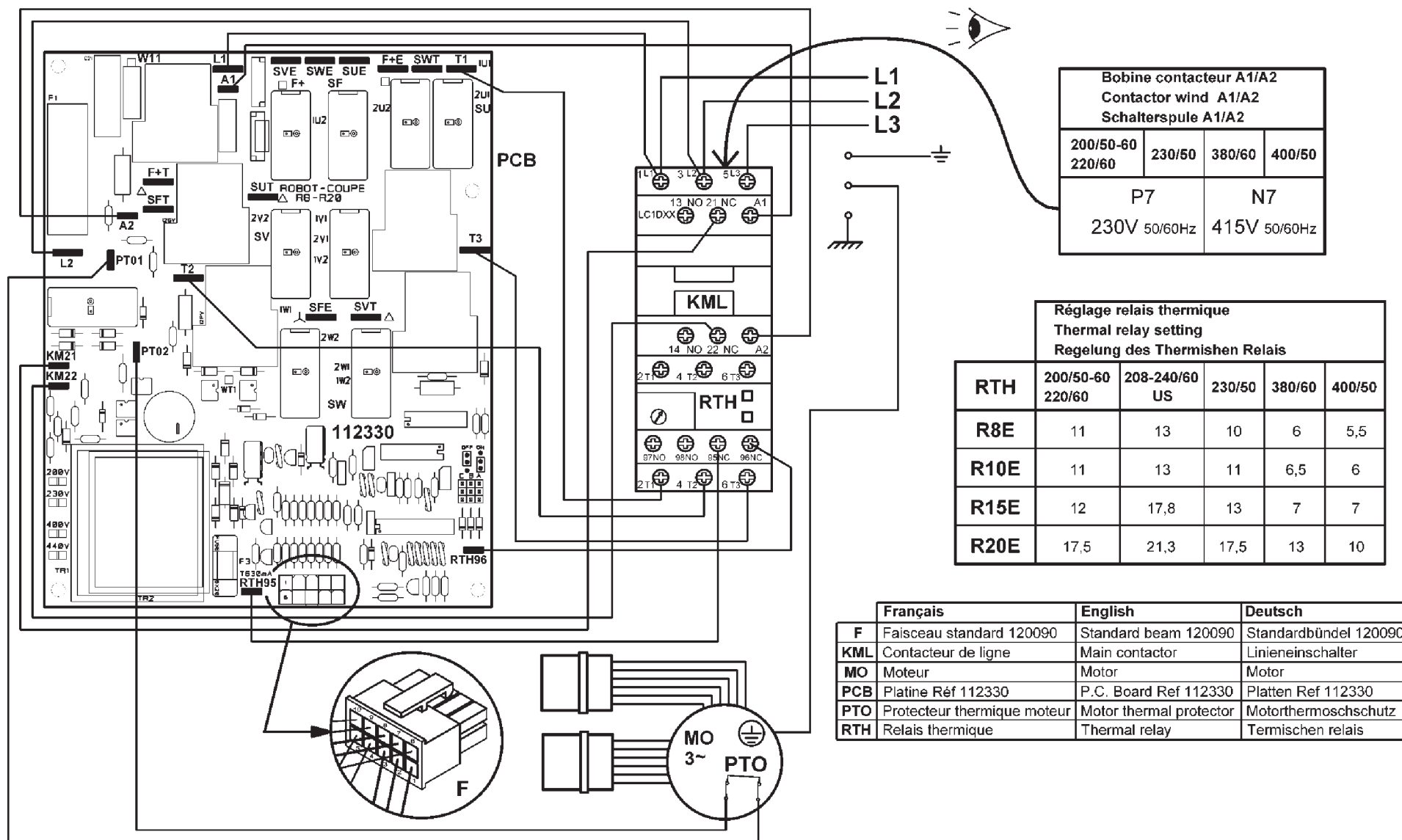

Bobine contacteur A1/A2 Contactor wind A1/A2 Schalterspule A1/A2			
200/50-60 220/60	230/50	380/60	400/50
P7 230V 50/60Hz		N7 415V 50/60Hz	

Réglage relais thermique Thermal relay setting Regelung des Thermischen Relais					
RTH	200/50-60 220/60	208-240/60 US	230/50	380/60	400/50
R8E	11	13	10	6	5,5
R10E	11	13	11	6,5	6
R15E	12	17,8	13	7	7
R20E	17,5	21,3	17,5	13	10

	Français	English	Deutsch
F	Faisceau standard 120090	Standard beam 120090	Standardbündel 120090
KML	Contacteur de ligne	Main contactor	Linieneinschalter
MO	Moteur	Motor	Motor
PCB	Platine Réf 112330	P.C. Board Ref 112330	Platten Ref 112330
PTO	Protecteur thermique moteur	Motor thermal protector	Motorthermoschutz
RTH	Relais thermique	Thermal relay	Thermischen relais

R8E - R10E - R15E - R20E
 SCHEMA ELECTRIQUE

BLIXER®8E - BLIXER®10E - BLIXER®15E - BLIXER®20E
 ELECTRIC DIAGRAM

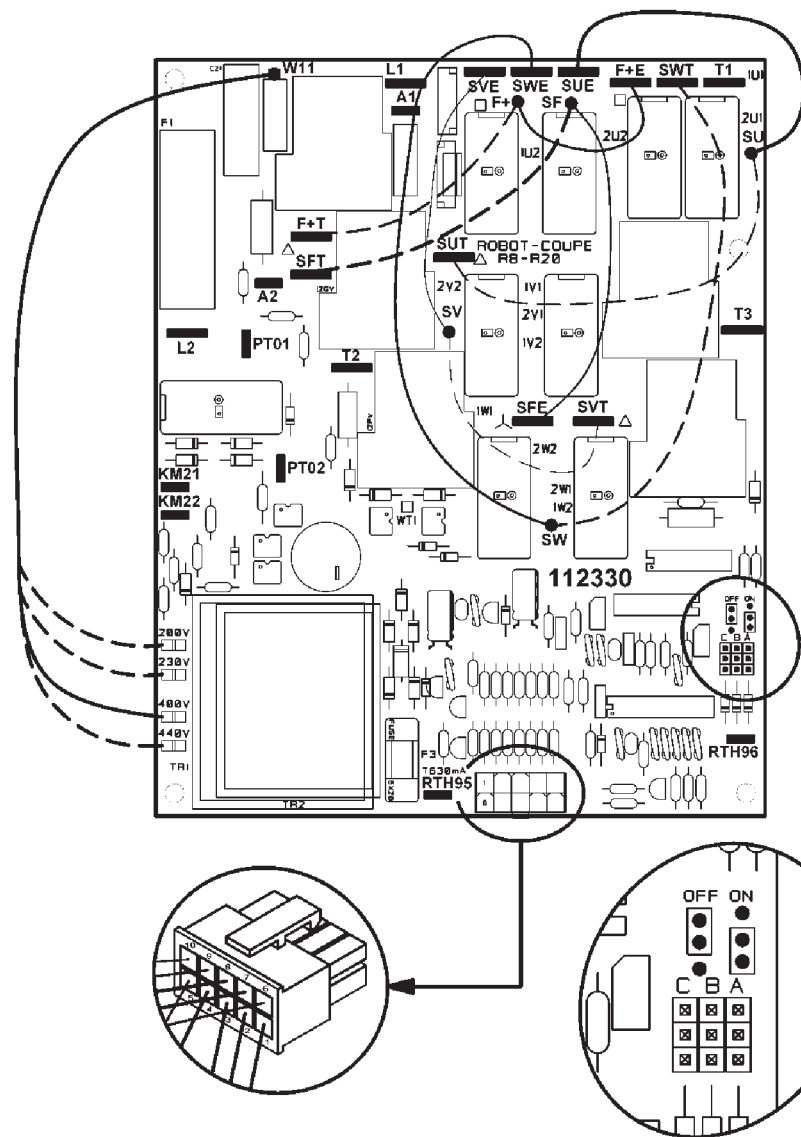

ELEKTRISCHES SCHALTBILD



CHECK LIST

 **Il y a 6 fils à commuter suivant la tension d'alimentation + contrôle tension bobine.**
There are 6 wires to connect according to the supply voltage + check voltage wind.
Es gibt 6 Kabeln müssen ungeschaltet werden entsprechend der Stromversorgung
 + Spannungskontrolle windt auf.

LE NON RESPECT DE CES INSTRUCTIONS DE CABLAGE ANNULERA VOTRE GARANTIE.
FAILURE TO FOLLOW THESE WIRING INSTRUCTIONS WILL VOID YOUR WARRANTY.
BEI NICHTBEFOLGUNG DER VERKABELLUNGSANLEITUNGEN VERFALT DIE GARANTIE.

		Tension d'alimentation / Supply voltage / Stromspannung			
Fils Wires Kabeln		200 V	220 V - 230 V	380 V - 400 V	440 V
	W11	200 V	230 V	400 V	440 V
gris / gray / grau	F+	F+T		F+E	
bleu / blue / blau	SF	SFT		SFE	
blanc / white / weiß	SU	SUT		SUE	
rouge / red / rot	SV	SVT		SVE	
jaune / yellow / gelb	SW	SWT		SWE	
					

R8E - R10E - R15E - R20E

BLIXER®8E - BLIXER®10E - BLIXER®15E - BLIXER®20E

200V/50-60Hz - 220V/60Hz - 230V/50Hz - 380V/60Hz - 400V/50Hz

SCHEMA ELECTRIQUE

ELECTRIC DIAGRAM

ELEKTRISCHES SCHALTBILD

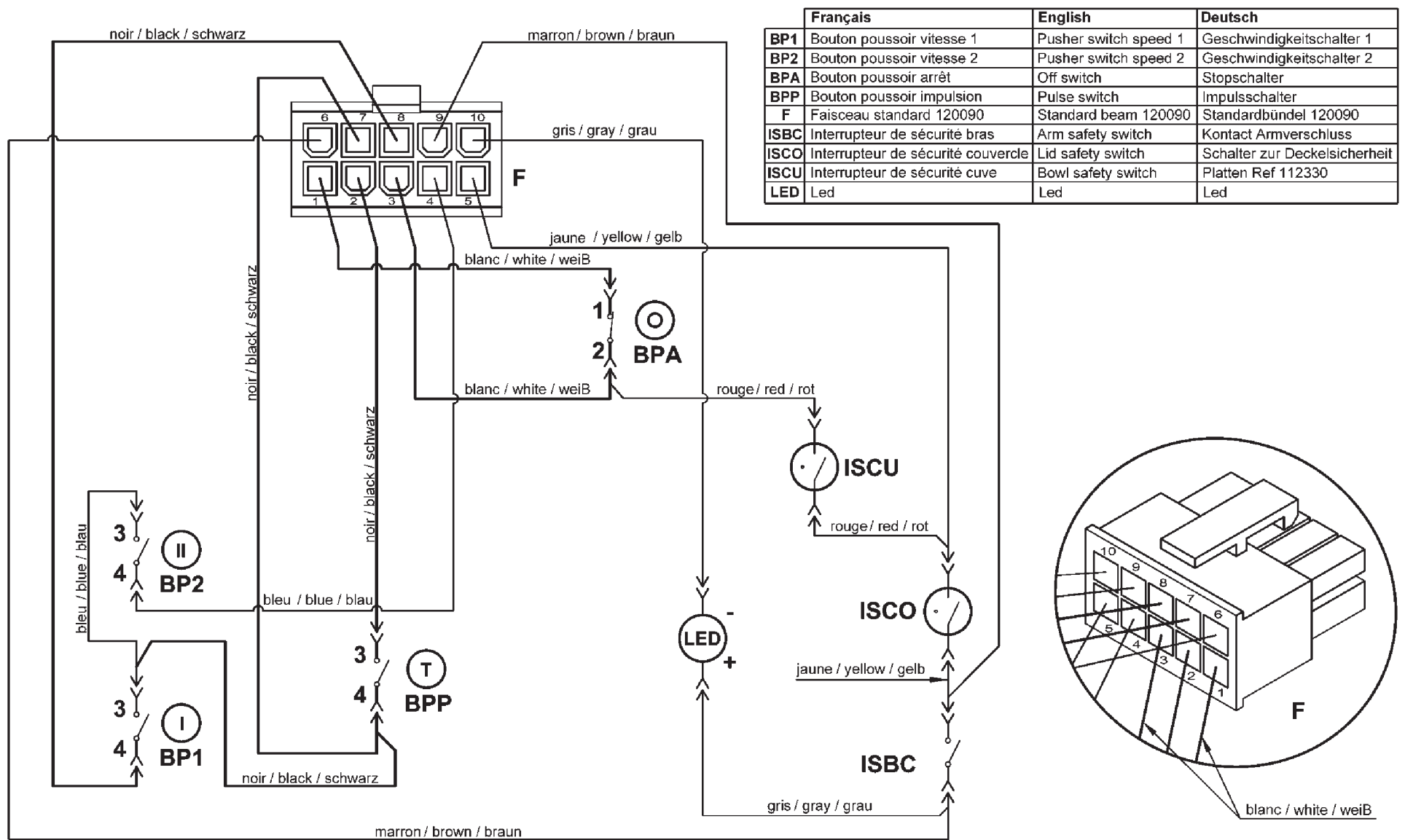

	Français	English	Deutsch
BP1	Bouton poussoir vitesse 1	Pusher switch speed 1	Geschwindigkeitsschalter 1
BP2	Bouton poussoir vitesse 2	Pusher switch speed 2	Geschwindigkeitsschalter 2
BPA	Bouton poussoir arrêt	Off switch	Stopschalter
BPP	Bouton poussoir impulsion	Pulse switch	Impulsschalter
F	Faisceau standard 120090	Standard beam 120090	Standardbündel 120090
ISBC	Interrupteur de sécurité bras	Arm safety switch	Kontakt Armverschluss
ISCO	Interrupteur de sécurité couvercle	Lid safety switch	Schalter zur Deckelsicherheit
ISCU	Interrupteur de sécurité cuve	Bowl safety switch	Platten Ref 112330
LED	Led	Led	Led

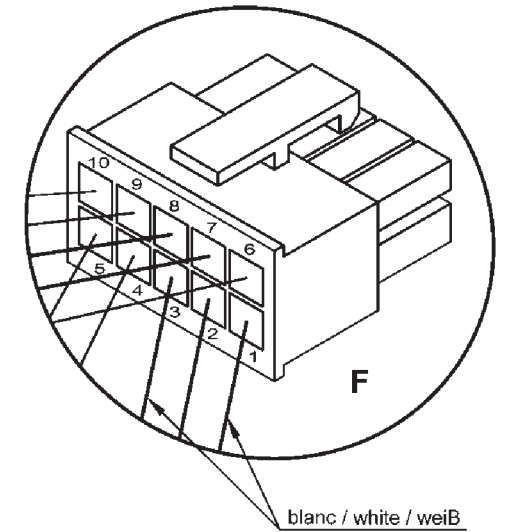



robot coupe[®]

Robot-coupe USA. Inc.

P.O. Box 16625, Jackson, MS 39236-6625
264 South Perkins St., Ridgeland, MS 39157
e-mail: info@robotcoupeusa.com
website: www.robotcoupeusa.com
Phone : 1-800-824-1646