

**LAVAVAJILLAS DE ARRASTRE  
ST**
**RACK CONVEYOR DISHWASHER  
ST**
**LAVE - VAISELLES À AVANCEMENT  
AUTOMATIQUE DE PANIERS ST**

N.	Denominación	Description	Dénomination	Cod.
1	Corona red/motriz Z1 (22)*	Reducer / Driving Gear Z1 (22)	Couronne Réd/Moteur Z1 (22)	2311538
2	Piñón conducido Z2 (26)*	Driven Gear Z2 (26)	Pignon Conduit Z2-24 (26)	2311539
3	Corona red/motriz Z1 (26)*	Reducer / Driving Gear Z1 (26)	Couronne Réd/Moteur Z1 (26)	2311694
4	S. Moyu arrastre ST2200*	Carriage Hub Set	ens. Moyeu Entraînement St2200	2311622
5	C. rodamientos sup. arrastre	Belt Spring	Ressort Bande	2311610
6	Chaveta 6-6-20	Key 6-6-20	Clavette 6-6-20	2050045
7	C. eje arrastre ST2200	Carriage Shaft ST	Axe Entraînement ST	2312639
8	Motor ST1700 0,12Kw 400V	Motor St 0.12Kw 400V	Moteur St1700 0.12Kw 400V	2311680
9	C. rodamiento inter. arrastre	Carriage Bearing Set (Inner)	Ens. Roulement Entraînement (Intérieur)	2312609
10	Tuerca autobloc.inox M-6 D-985	Washer D-985 M-6	Écrou D-985 M-6 Aut. Inox	2305418
11	Limitador de par T120/65	Torque Limiter T120/65	Limiteur De Couple T120/65	2311534
12	C. rodamientos inf. arrastre	Carriage Bearing Set(Lower)	Ens. Roulement Entraînement (Inférieur)	2312611
13	Cadena reductor 1/2x5/16	Reducer Chain 1/2"X5/16"	Chaîne Réducteur 1/2"X5/16"	2311541
14	Reductor coaxial HA32P I:60.7	Reducer Ha32P I:60.7	Réducteur Coaxial Ha32P I:60.7	2311582
15	Motor ST2200 0,12/0,18Kw 400V	Motor St 0.12/0.18Kw 400V	Moteur St2200 0.12/0.18Kw 400V	2311687
16	Arandela Moyu arrastre ST2200	Carriage Hub Washer	Rondelle Moyeu Entrain.ST2200	2311707
17	Piñón conducido Z2-24 ST3000	Driven Gear Z2-24	Pignon Conduit Z2-24 ST3000	2312003
18	Patín inf. arrastre ST2200*(MB)	Carriage Bar Sliding Support	Taquet Inf.Entraînement ST2200	2311501
19	Protector trans.tras. ST2200	Tail Transmission Protection ST	Protecteur De Transmission Arrière	2311678
20	C. uña arrastre ST	Carriage Hook Set ST	Ens.Crochet Entraînement ST	2312613
21	Protector transm. ST2200	Transmission Protection ST	Protecteur De Transmission ST	2311670
22	Corredera de arrastre	Carriage Slider	Chariot D'Entraînement	2311547
23	Barra arrastre ST-2200 DCHA	Pulling Bar Right	Barre Entrain.St2200 Droite	2311523
24	C. patín sup. arrastre ST2200	Ens. Crochet Entraînement ST	Carriage Hook Set ST	2312614
25	C. tornillo + tuerca + arandela	Screw+Washer+Ring Set	Ens. Vis+Écrou+Rondelle	2312647
26	C. tornillo arrastre ST	Carriage Hook Screw Set ST	Ens. Vis Entraînement ST	2312612
27	Barra arrastre ST2200 IZDA	Pulling Bar Left	Barre Entraîn.St2200 Gauche	2311718



**LAVAVAJILLAS DE ARRASTRE  
ST**
**RACK CONVEYOR DISHWASHER  
ST**
**LAVE - VAISELLES À AVANCEMENT  
AUTOMATIQUE DE PANIERS ST**

N.	Denominación	Description	Dénomination	Cod.
28	Fijación superior tubos lavado	Washing Tubes Holder (upper)	Fixation supérieure tubes lavage	2311580
29	Fijación inferior tubos lavado	Washing Tubes Holder (lower)	Fixation inférieure tubes lavage	2311578
30	S. distribuidor lavado ST	Washing Distributor Set ST	Ens distributeur lavage ST	2311572
31	Codo impulsión diam. 62	Intake Elbow Ø62 ref. 168	Coude impuls. diam. 62 ref. 168	2311176
32	Tubo reducción diam. 53-63	Diam. Reduction Tube 53-63	Tube reduc. diam. 53-63	2311178
33	Junta goma distrib. 100x80x4	Rubber Gasket Distrib. 100x80x4	Joint Caout. distrib. 100x80x4	2311560
34	C. juntas tóricas lavado	Washing Spring Ring Set	Ens joint Tor. lavage ST	2312606
35	C. tuerca distrib. lavado ST	Washing Distributor Washer Set ST	Ens écrou distr. rinç. ST	2312607
36	S. tubo lavado tipo A	Washing Hose Type A	Tube lavage type A	2311795
37	Tubo trasero sup. lav. ST	Upper Back Washing Tube ST	Tube arrière supérieure lavage ST	2311570
38	C. casquillo lavado ST	Washing Washer Set ST	Baque de lavage ST	2312608
39	Te de lavado ref. 164	Washing "T" ref. 164	T de lavage ref. 164	2311590
40	Codo superior lavado ref. 163	Washing Upper Elbow ref. 163	Coude sup lavage ref. 163	2311592
41	Codo trasero lavado ST	Back Washing Elbow ST	Coude arrière lavage ST	2311613
42	Tubo impulsión ST	Intake Tube ST	Tube impulsion ST	2311729
43	S. tubo lavado tipo B	Washing Hose Type B	Tube lavage type B	2311796
44	Abrazadera Mikalor 50-70	Support Mikalor 50-70	Collier Mikalor 50-70	2002605
45	Abrazadera Mikalor 70-90	Support Mikalor 70-90	Collier Mikalor 70-90	2306154
46	Sujeción inf. tubo aclar.	Rinse Tube Holder (lower)	Support inférieur tubes rinçage ST	2311571
47	Difusor aclarado 1/8 0,5 l / min	Rinse Aid Disperset 1/8 0.5 l / m	Diffuseur rinç. 1/8 0.5 l / min	2311569
48	Tuerca acoplador aclar.	Rinse Coupling Washer	Ecrou accoupl. rinçage	2311593
49	C. junta acoplador aclarado	Rinsing Coupling Gasket Set	Ens joints accoupleur rinç. ST	2312605
50	S. tubo aclarado	Rinse Hose Set	Tube rinçage ST	2311832
51	C. distribuidor aclarado ST	Rinse Distributor Set ST	Ens distributeur rinçage ST	2312604
52	Sujeción sup. tubo aclar.	Rinse Tube Holder (upper)	Support supérieur tuyau rinçage	2311596

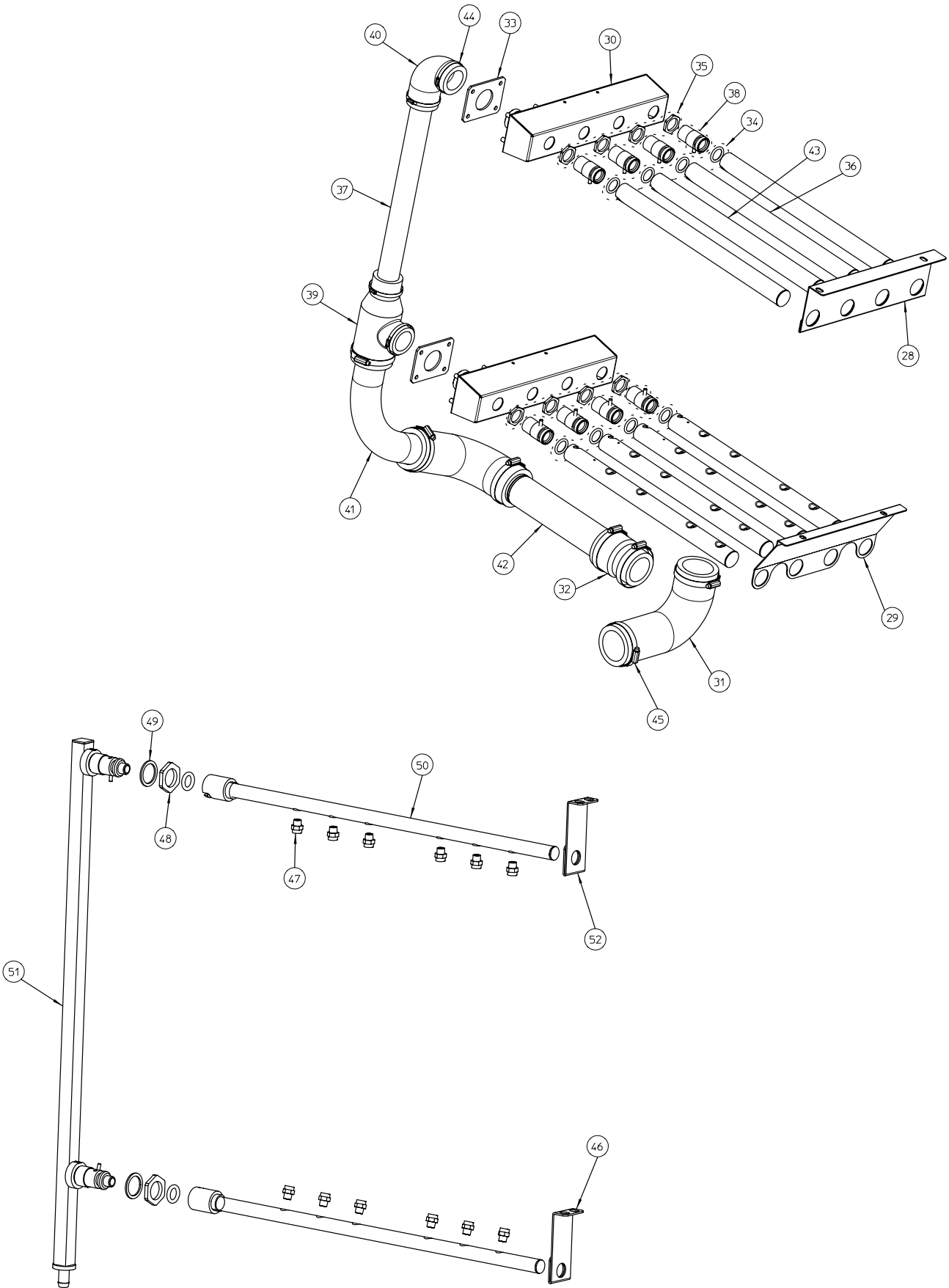
**ST**

Nota: Todas estas especificaciones están sujetas a cambio sin previo aviso, debido a la permanente mejora del producto.  
 Note: These specifications are subject to change without notice due to continuous improvement.  
 Note: SAMMIC se réserve le droit de modifier et d'améliorer ses fabrications sans préavis.

**LAVAVAJILLAS DE ARRASTRE  
ST**
**RACK CONVEYOR DISHWASHER  
ST**
**LAVE - VAISELLES À AVANCEMENT  
AUTOMATIQUE DE PANIERS ST**

N.	Denominación	Description	Dénomination	Cod.
53	C. cortina antisalpicadero int.	Splash Guard Set Int.	Ens rideau anti-éclaboussures intérieur	2312618
54	C. cortina intermedia	Intermediate Curtain Set	Ens rideau intermédiaire	2312616
55	C. cortina antisalpicadero	Splash Guard Set	Ens rideau anti-éclaboussures	2312615
56	C. apoyo cortina	Curtain Holder Set	Ens appui rideau	2312617
57	C. tuerca + arandela	Washer + Flat Washer	Ens écrou + rondelle	2312648
58	Presostato 130-40 mm.	Pressurestat 130-40 mm	Pressostat 130-40 mm	2302816
59	Guías cesta ST	Rack Guides ST	Guides panier ST	2311521
60	Tapa lateral izdo	Left Side Cover	Panneau lateral gau.	2311527
61	Tapa inferior base ST	Lower Base Cover ST	Couvercle inférieur Base ST	2311516
62	Soporte Moyu arrastre ST	Carriage Hub Support ST	Support Moyeu transport STS	2311621
63	Tapa trasera	Back Cover	Panneau arrière	2311648
64	Protector presostato	Pressurestat Protection	Protecteur pressostat ST	2311652
65	Tapa lateral dcho	Right Side Cover	Panneau lateral dr.	2311685
66	Tapa trasera	Left Back Cover	Panneau arrière gauche	2311689
67	Tapa cableado ST	Wiring Cover ST	Couvercle câblage ST	2311690
68	Faldón inf. tras. ST	Lower Back Panel ST	Panneau inf. arrière	2311693
69	S. tapa aisl. tablero ST	Control Panel Insulation Cover ST	S. couvercle isolat. panneau ST	2311699
70	Soporte motobomba ST	Motorpump Holder ST	Support pompe ST	2311728
71	Panel mandos ST	Control Panel ST	Panneau commande ST	2311764
72	Soporte junta p. mandos	Control Panel Grommets Support	Support joint panneau commande	2311766
73	Cubierta panel mandos ST	Control Panel Cover ST	Capot panneau commande ST	2311763
74	S. filtro cuba ST	Cuve Filter ST	S. filtre Cuve ST	2311787
75	Tapa trasera panel	Back Cover Panel	Panneau arriere p.commande ST	2311788
76	S. laberint. carr. ST	Laberynth Cover ST	S. maze ST	2311819
77	Soporte tubo lavado ST	Washing Tube Holder ST	Support tube lavage ST	2311849
78	S. rebosadero ST	Drain Plug Set ST	Ens bloqueur d'eau ST	2311594
79	C. desagüe ST	Drain Set ST	Ens. evacuation ST-2200	2312630
80	C. tapón macho 3/4 gas	Male Plug Set 3/4 Gas	Ens. bouchon male 3/4 gas	2312631
81	Conj. campana presostato	Pressurestat Bowl Set	Ensemble cloche Pressostat	2309200
82	C. tapón macho 1/2 gas	Male Plug Set 1/2 Gas	Ens. bouchon 1/2 gas	2312632
83	C. acces. motobomba 3,2	Motorpump Acces. Set 3.2	Ens access pompe 3.2	2319043
84	C. boca entrada agua ST	Water Inlet Set ST	Ens. bouche entree eau	2312636
85	C. amortiguador cilíndrico ST	Cylindric Schock Absorber ST	Ens.amortisseur cylindrique	2312629
86	Sonda temperatura NTC 1/8 inox	Temperature Probe NTC 1/8 inox	Sonde temperature NIC 1/8 inox	2311663
87	Termostato seguridad C/Bulbo	Safety Thermostat with Sensor	Thermost. secu. avec bulbe	2311713
88	C. resistencia cald. 9kw	Boiler Element Set 9 kw.	Ens resistance chaudiere 9 kw.	2309858
89	Junta tórica resist. 52-8 1065	Element Spring Ring 52-8 1065	Joint tor. resist. 52-8 1065	2304983
90	Motobomba 3,2	Motorpump 3.2	Pompe 3.2	2310969
91	Pata ST	Adjustable Foot ST	Pied ST2200	2311803
92	S. interrup. magnético	Magnetic Switch	Interrupteur magnetique	2050705
93	C. filt. recogedor ST	Filter ST	Ens filtre recupérateur ST	2311674
94	S. filtro sup. ST	Upper Filter Set ST	Ens. filtre supérieure ST	2311655
95	Filtro aspiración	Aspiration Filter Set	Filtre aspiration	2311095
96	C. carcasa motobomba 3,2	Motorpump Cover Set 3.2	Ens.carcasse pompe 3,2	2319047
97	C. mandos termostato	Thermostat Knob	Commande de thermostat	2309065
98	C. termostato aclarado	Rinsing Thermostat Set	Ensemble thermostat de rinçage	2309068
99	Protec. termost. ST	Thermostat Protection ST	Protecteur thermostat ST	2311806

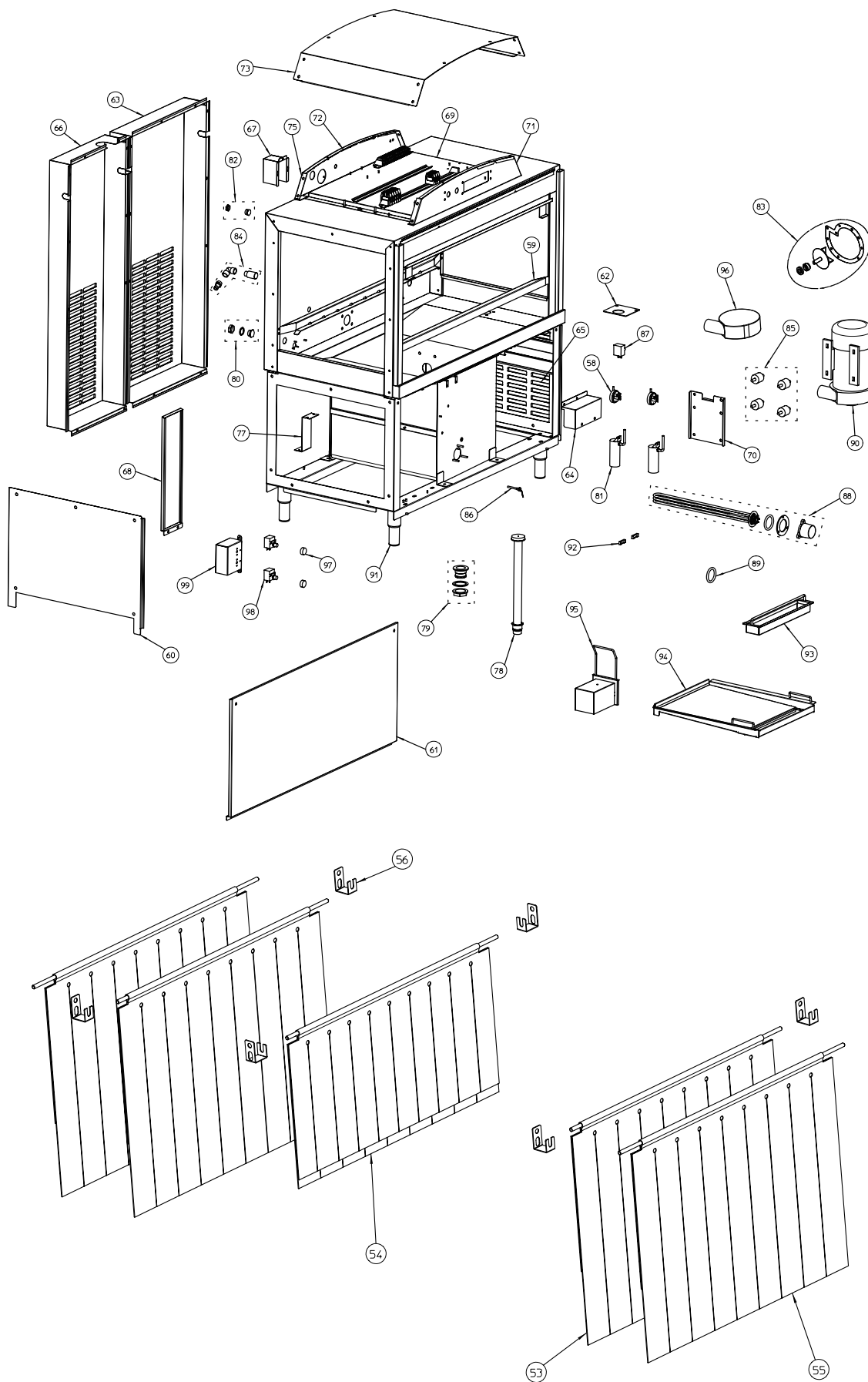
**ST**

Nota: Todas estas especificaciones están sujetas a cambio sin previo aviso, debido a la permanente mejora del producto.  
 Note: These specifications are subject to change without notice due to continuous improvement.  
 Note: SAMMIC se réserve le droit de modifier et d'améliorer ses fabrications sans préavis.

**LAVAVAJILLAS DE ARRASTRE  
ST**
**RACK CONVEYOR DISHWASHER  
ST**
**LAVE - VAISELLES À AVANCEMENT  
AUTOMATIQUE DE PANIERS ST**

N.	Denominación	Description	Dénomination	Cod.
100	Tubo de goma	Rubber hose	Tube caoutchouc	2306082
101	C. resistencia cald. 9kw	Boiler element set 9 kw.	Ens resistance chaudiere 9 kw.	2309858
102	C. juntas calderín	Boiler element subber seal	Joint caoutch resist chaud	2309051
103	S. calderín ST	Boiler set ST	Chaudiere ST	2311559
104	Sonda temperatura NTC 1/8 inox	Temperature probe ntc 1/8 inox	Sonde temperature ntc 1/8 inox	2311663
105	Racord doble-macho 1/2	Double racord-male 1/2	Raccord double-mâle 1/2	2600252
106	Unión de 1/2 cónica	Conic union 1/2	Union de 1/2 cônica	2311829
107	Soporte válvulas ST	Valve holder ST	Support valves ST	2311799
108	Terminal macho 12-1/2 k	Terminal male 12 - 1/2	Terminal mâle 12-1/2 k	2311746
109	Unión macho-macho 3/4 k	Male-male union 3/4 k	Union mâle-mâle 3/4 k	2311745
110	Te hembra 1/2 gas	Female t 1/2 gas	T femelle 1/2 gaz	2311742
111	Codo macho/macho 1/2 k	Elbow m/m 1/2 k	Coude male/male 1/2 k	2311741
112	Codo macho 1/4 K - hemb. 1/4 cil.	Elbow male 1/4 - fem. 1/4 cyl	Coude male 1/4 k - hemb.1/4 cil	2311740
113	Codo macho 3/4 K - hemb. 3/4 cil.	Elbow male 3/4 - fem. 3/4 cyl	Coude male 3/4 k-hemb. 3/4 cil	2311739
114	Filtro Y de 3/4	Filter y 3/4	Filtre y 3/4	2311738
115	Electroválvula diam. 12 230 V.	Electrovalve ø12 230 V	Electrovanne diam.12 230 V	2311737
116	Manómetro vertical 1/4	Vertical pressure gauge 1/4	Manometre vertical 1/4	2311736
117	Valv. reductora presión	Pressure reducer valve	Valve reduct. pression	2311735
118	Racord reducc. macho 3/4 - 1/2	Reducer racord male 3/4 - 1/2	Raccord reduc.mâle 3/4 - 1/2	2140666

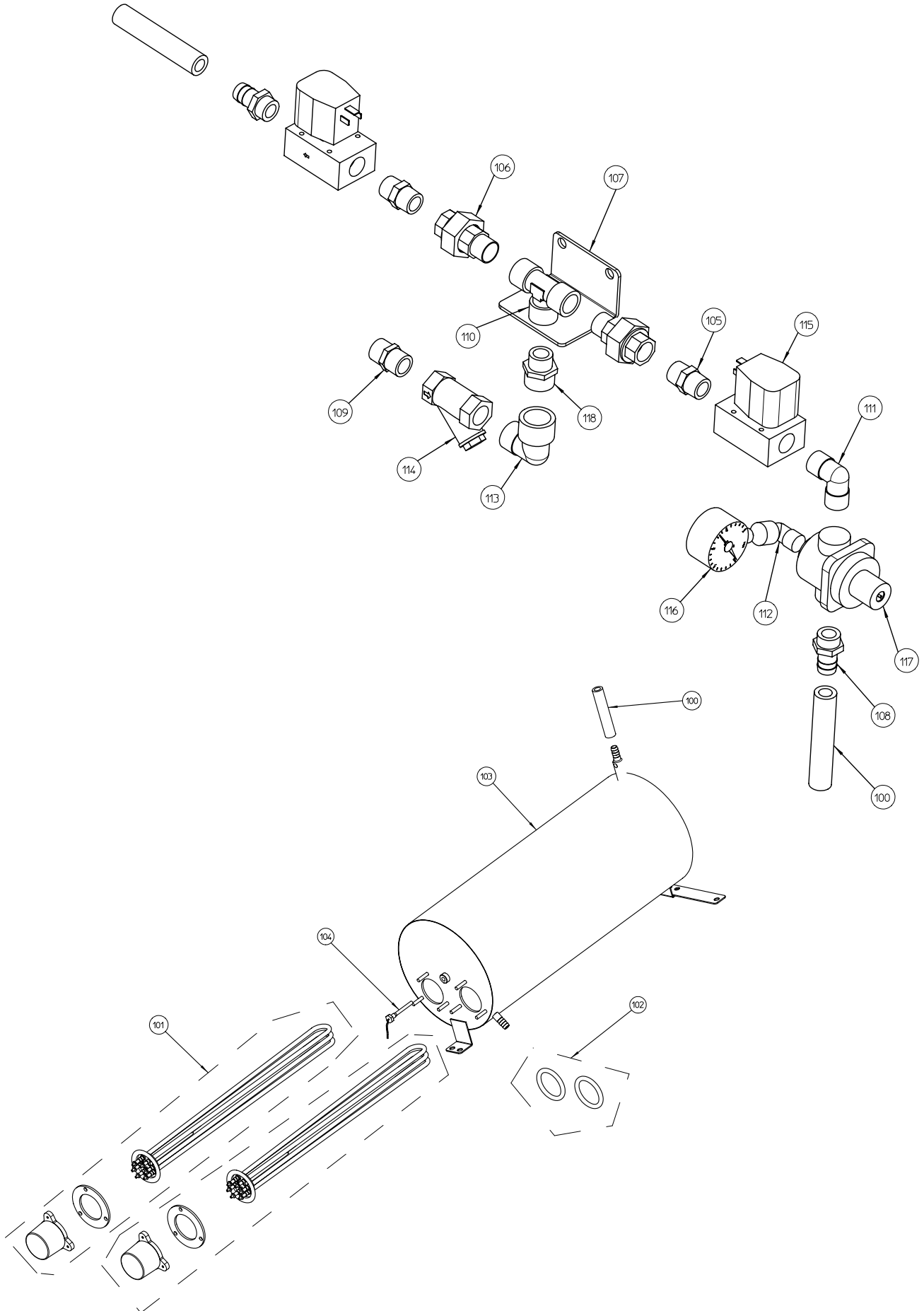
**ST**

Nota: Todas estas especificaciones están sujetas a cambio sin previo aviso, debido a la permanente mejora del producto.  
 Note: These specifications are subject to change without notice due to continuous improvement.  
 Note: SAMMIC se réserve le droit de modifier et d'améliorer ses fabrications sans préavis.



**LAVAVAJILLAS DE ARRASTRE  
ST**
**RACK CONVEYOR DISHWASHER  
ST**
**LAVE - VAISELLES À AVANCEMENT  
AUTOMATIQUE DE PANIERS ST**

N.	Denominación	Description	Dénomination	Cod.
119	Sensor magnético D12P ST	Magnetic sensor D12P ST	Senseur magnet. D12P ST	2311717
120	Imán M370/AP ST	Magnet M370/AP ST	Aimant M370/AP ST	2311812
121	S. palanca micro ST	Micro-switch lever set ST	ens. levier micro ST	2311825
122	C. racor detector palanca micro	Micro lever detector raccord set	Raccord detect. levier micro	2312621
123	C. tuerca + arandela	Washer + flat washer set	ens. Écrou + rondelle	2312650
124	Abrazadera Mikalor 50-70	Support mikalor 50-70	Collier mikalor 50-70	2002605
125	Abrazadera Sinfin inox. 32-50	Worm drive support 32-50	Collier sansfin inox.32-50	2304003
126	C. casquillo lavado ST	Washing washer set ST	Baque de lavage ST	2312608
127	S. tubo lavado tipo A	Washing hose type A	Tube lavage type A	2311795
128	Codo impulsión	Intake elbow	Coude impuls.	2306238
129	Codo lavado	Washing elbow	Coude lavage	2310607
130	Junta goma distrib. 100x80x4	Rubber gasket distrib.100x80x4	Joint caout.distrib.100x80x4	2311560
131	S. tubo lavado tipo B	Washing hose type B	Tube lavage type B	2311796
132	C. tuerca distrib. lavado	Washing distributor washer set	ens. écrou distributeur lavage	2312607
133	C. juntas tóricas lavado	Washing spring ring set	ens. joint tor. lavage	2312606
134	S. distribuidor prelav.	Pre-wash distributor set	Ens. Distributeur pré-lavage	2311865
135	Sujeción inf. prelavado	Pre-wash lower support	Maintien inférieur pré-lavage	2311864
136	Sujeción sup. prelavado	Pre-wash upper support	Maintien supérieur pré-lavage	2311866
137	Casquillo reductor prelavado	Pre-wash reducer socket	Bague réducteur pré-lavage	2312045
138	T prelavado ST	Pre-wash ST	T pré-lavage ST	2312049
139	Tubo impulsión prelav.	Pre-wash Intake hose	Tube impulsion pré-lavage	2312050
140	Tubo trasero prelavado	Pre-wash back hose	Tube arrière pré-lavage	2312051

ST

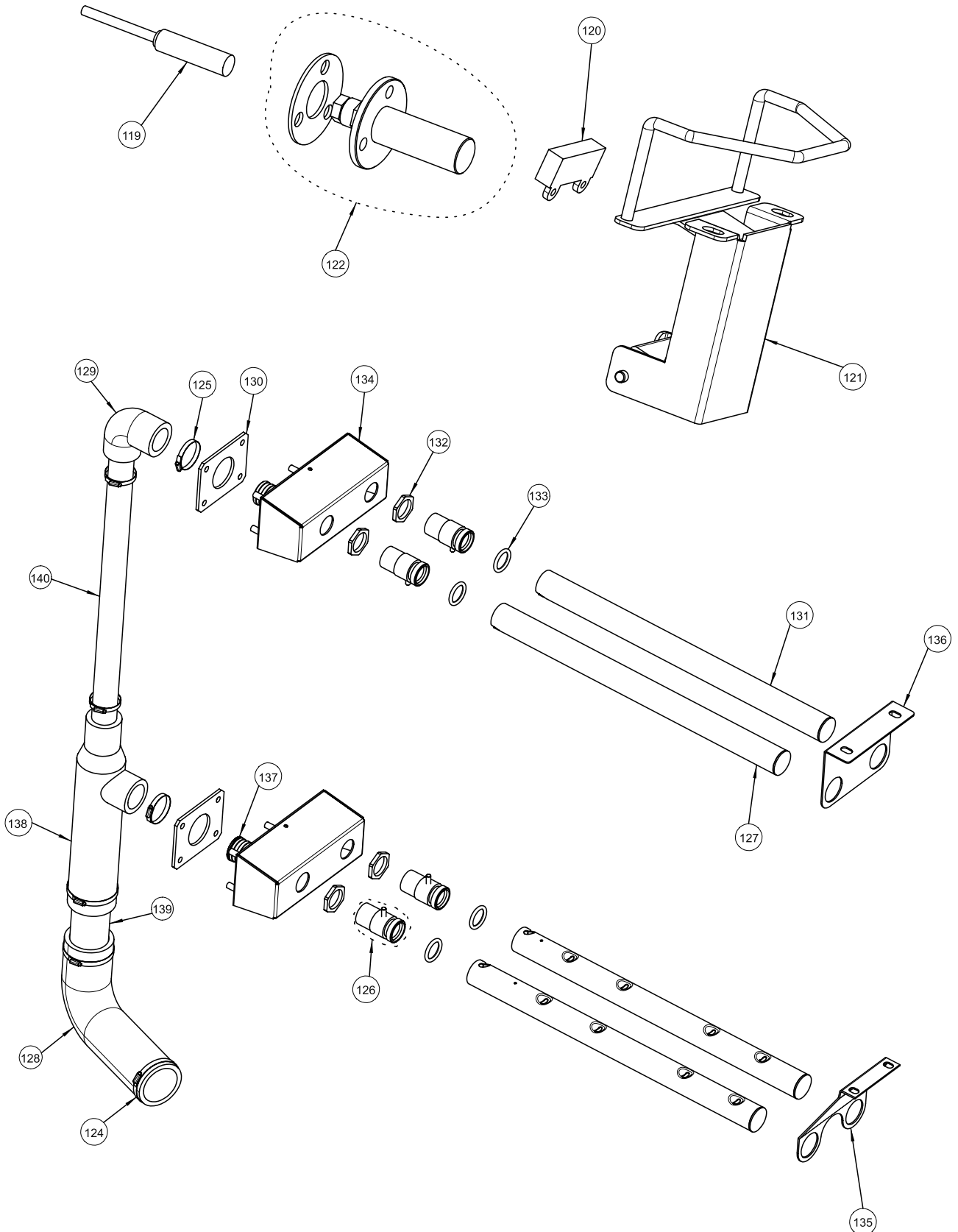

Nota: Todas estas especificaciones están sujetas a cambio sin previo aviso, debido a la permanente mejora del producto.  
 Note: These specifications are subject to change without notice due to continuous improvement.  
 Note: SAMMIC se réserve le droit de modifier et d'améliorer ses fabrications sans préavis.

**LAVAVAJILLAS DE ARRASTRE  
ST**

**RACK CONVEYOR DISHWASHER  
ST**

**LAVE - VAISELLES À AVANCEMENT  
AUTOMATIQUE DE PANIERS ST**

N.	Denominación	Description	Dénomination	Cod.
141	Varilla sujeción cortina int.	Inside curtain holder rod	Barrette maintien rideau int.	2311625
142	S. apoyo cortina prelavado	Pre-wash curtain support set	Ens. Appui rideau pré-lavage	2312055
143	Cortina intermedia prelavado	Pre-wash middle curtain	Rideau intermède. pré-lavage	2312056
144	C. tuerca + arandela	Washer + flat washer set	Ens. Écrou + rondelle	2312651
145	S. segurid. puerta ST	Door safety set ST	Ens. sécurité porte ST	2311636
146	S. sop. muelle ST	Spring holder set ST	Ens. support ressort ST	2311669
147	C. muelle puerta túnel lavado	Washing tunnel door spring set	Ens. Ressort porte tunnel lavage	2312620
148	C. puerta prelavado	Pre-wash door set	Ens. Porte pré-lavage	2312633
149	C. tornillo + tuerca + arandela	Screw + washer + flat washer set	Ens. Vis + écrou + rondelle	2312652
150	Conjunto guías puerta	Door guide set	Ens. guides porte	2312641
151	Conjunto taco puerta	Door block set	Ens. taquet porte	2312642

ST

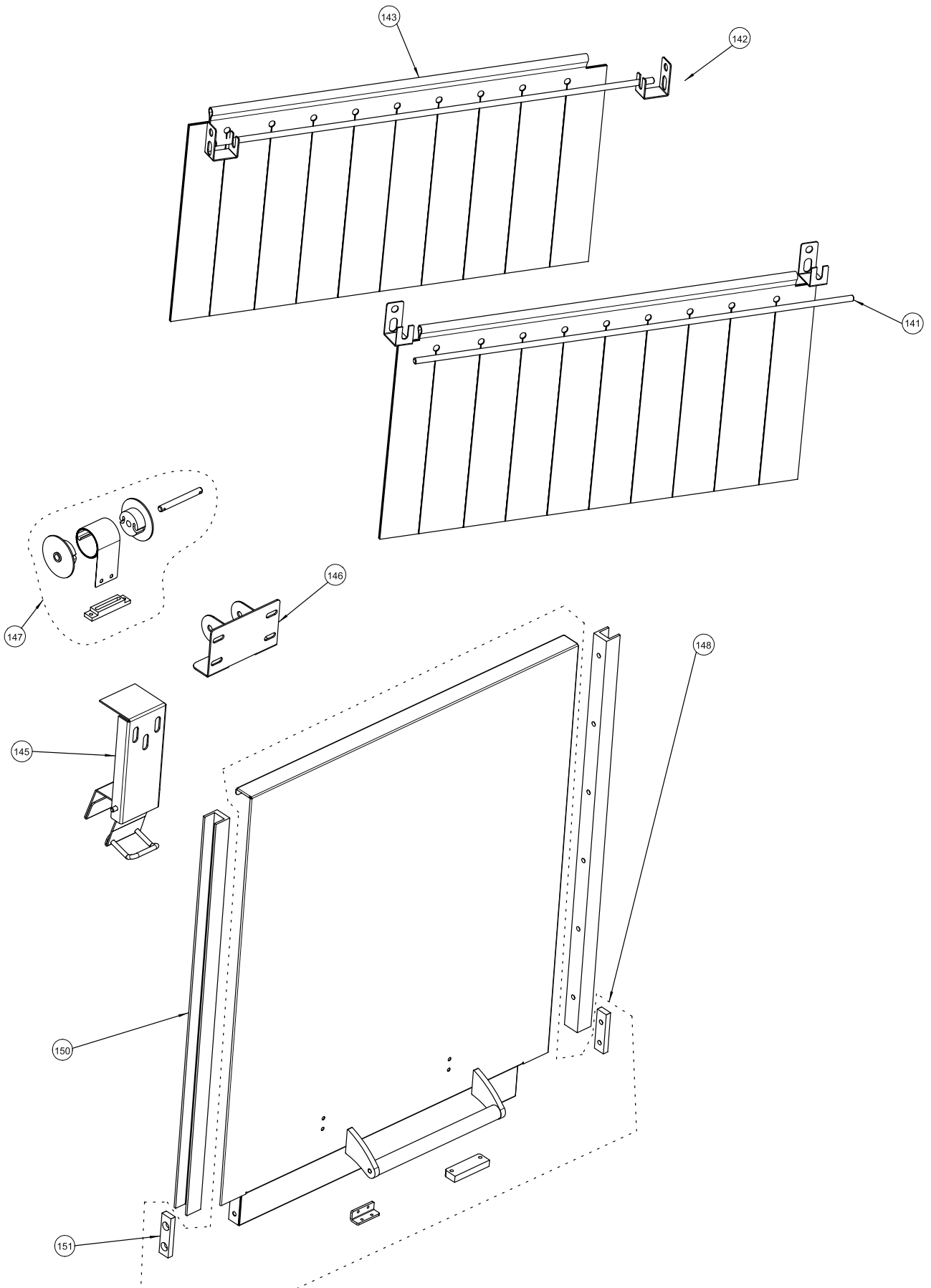

Nota: Todas estas especificaciones están sujetas a cambio sin previo aviso, debido a la permanente mejora del producto.  
 Note: These specifications are subject to change without notice due to continuous improvement.  
 Note: SAMMIC se réserve le droit de modifier et d'améliorer ses fabrications sans préavis.

**LAVAVAJILLAS DE ARRASTRE  
ST**
**RACK CONVEYOR DISHWASHER  
ST**
**LAVE - VAISELLES À AVANCEMENT  
AUTOMATIQUE DE PANIERS ST**

N.	Denominación	Description	Dénomination	Cod.
152	Tubo de goma	Rubber hose	Tube caoutchouc	2306082
153	Racord reducc. macho 3/4 - 1/2	Reducer raccord male 3/4 - 1/2	Raccord reduc. mâle 3/4 - 1/2	2140666
154	Electroválvula diam. 12 230V.	Electrovalve ø12 230V	Électrovanne diam.12 230V	2311737
155	Filtro Y de 3/4	Filter y 3/4	Filtre y 3/4	2311738
156	Codo hembra/hembra 1/2	Elbow f/f 1/2	Coude femelle/femelle 1/2	2311744
157	Unión macho-macho 3/4 K	Male-male union 3/4 K	Union mâle-mâle 3/4 K	2311745
158	Terminal macho 12-1/2 K	Terminal male 12-1/2 K	Terminal mâle 12-1/2 K	2311746
159	S. sop. electrov. prelav.	Pre-wash electrovalve support set	Ens. Support électrovalve pré-lavage	2311881
160	Racord doble-macho 1/2	Double raccord-male 1/2	Raccord double-mâle 1/2	2600252
161	C. patín sup. arrastre	Carriage bar sliding sup/upper	Taquet sup. entraînement	2312614
162	C. uña arrastre ST	Carriage hook set ST	Ens. crochet entraînement ST	2312613
163	Unión barra arrastre prelavado	Pre-wash pulling bar union	Union barre entr. pré-lavage	2312034
164	Patín inf. arrastre	Carriage bar sliding support	Taquet inf. entraînement	2311501
165	Supl. barra arrastre prelavado	Pre-wash pulling bar	Supl. barre entr. pré-lavage	2312036
166	Calzo patín prelavado	Carriage bar sliding supp base	Patin pré-lavage	2312076
167	C. tornillo arrastre ST	Carriage hook screw set ST	ens. vis entraînement ST	2312612
168	Pletina unión barra	Carriage bar union flat arm	Platine union barre	2312113
169	C. tornillo + tuerca + arandela	Screw + washer + flat washer set	ens. Vis + écrou + rondelle	2312653

ST

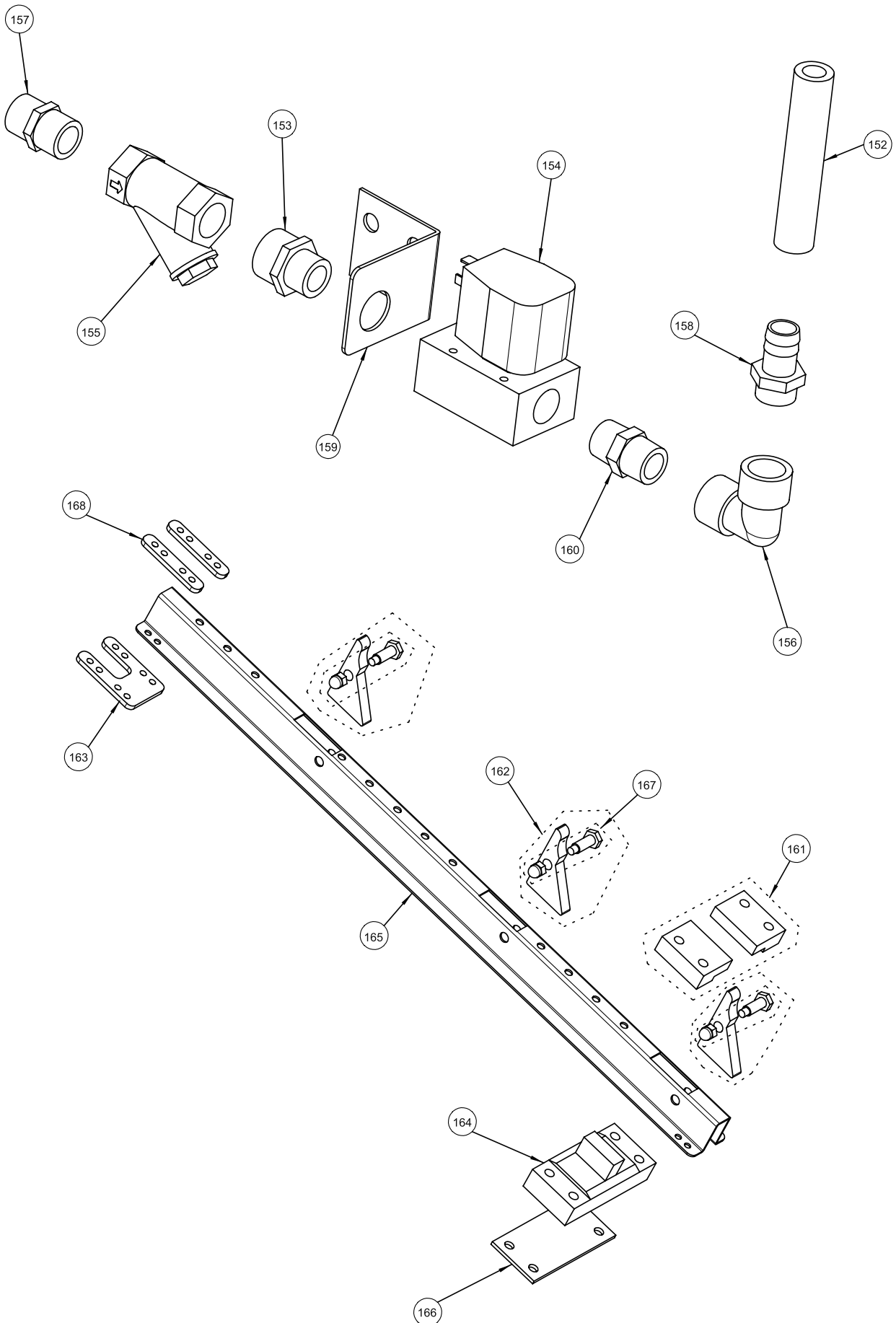

Nota: Todas estas especificaciones están sujetas a cambio sin previo aviso, debido a la permanente mejora del producto.  
 Note: These specifications are subject to change without notice due to continuous improvement.  
 Note: SAMMIC se réserve le droit de modifier et d'améliorer ses fabrications sans préavis.

**LAVAVAJILLAS DE ARRASTRE  
ST**
**RACK CONVEYOR DISHWASHER  
ST**
**LAVE - VAISELLES À AVANCEMENT  
AUTOMATIQUE DE PANIERS ST**

N.	Denominación	Description	Dénomination	Cod.
170	C. tapón macho 1/2 gas	Male plug set 1/2 gas	ens. bouchon 1/2 gaz	2312632
171	Guía cesta pre/lav. Y acl. ST	Pre-wash rack guide ST	Guide panier pré-lavage ST	2312008
172	S. laberinto prelavado ST	Pre-wash maze set ST	ens. labyrinthite pré-lavage ST	2312018
173	Presostato 130-40 mm.	Pressurestat 130-40mm	Pressostat 130-40 mm	2302816
174	Tapa inf. base prelavado	Pre-wash base lower cover	Couvercle inférieur base pré-lavage	2312021
175	Tapa trasera prelavado	Pre-wash back cover	Panneau arrière pré lavage	2312024
176	Filtro recogedor prelavado	Pre-wash filter	Filtre récupérateur pré-lavage	2312030
177	S. filtro sup. prelavado	Pre-wash upper filter set	Filtre sup. pré-lavage	2312043
178	Soporte motobomba prelavado	Pre-wash pump holder	Support pompe pré-lavage	2312061
179	Separador prelavado	Pre-wash separator	Séparateur pré-lavage	2312070
180	Unión apoyo cesta prelavado	Pre-wash rack holding union	Union appui panier pré-lavage	2312072
181	Tapa racord prelavado	Pre-wash raccord cover	Couvercle raccord pré-lavage	2312073
182	Apoyo central filt. prelavado	Pre-wash filter central support	Appui centrale filtre p. lavage	2312075
183	Conj. campana presostato	Pressurestat bowl set	Ensemble cloche pressostat	2309200
184	C. boca entrada agua ST	Water inlet set ST	ens. bouche entrée eau ST	2312636
185	Codo aspiración	Intake elbow	Coude aspiration	2306234
186	C. desagüe ST	Drain set ST	ens. évacuation ST	2312630
187	Filtro aspiración	Aspiration filter set	Filtre aspiration	2311095
188	Pata ST	Adjustable foot ST	Pied ST	2311803
189	C. racord unión prelavado	Pre-wash union raccord set	ens. raccord union pré lavage	2312634
190	Protector presostato ST	Pressurestat protection ST	Protecteur pressostat ST	2311652
191	Refuerzo pata ST	Foot strengthening ST	Renforcement pied ST	2311640
192	C. rebosadero prelavado	Pre-wash drain plug set	ens. bloqueur d'eau pré-lavage	2312047
193	C. casquillo roscado filtro	Filter threaded socket set	Ens. bague pas de vis filtre	2312635
194	Tubo conexión cuba prelavado	Pre-wash tank connecting hose	Tuyau connexion cuve pré-lavage	8100539
195	Motobomba prelavado 1,2	Pre-wash pump 1.2	Pompe de pré-lavage 1,2	2311827
196	C. acces. motobomba 1,2	Pump access. set 1,2	ens. accès motopompe 1,2	2309841
197	C. carcasas bomba	Pump body set	Ensemble corps motopompe	2309842
198	Termostato seguridad c/bulbo	Safety thermostat with sensor	Thermost. secu. avec bulbe	2311713
199	S. interrup. magnético	Magnetic switch	Interrupteur magnétique	2050705
200	Abrazadera Sinfin inox. 32-50	Worm drive support 32-50	Collier sans fin inox.32-50	2304003
201	Abrazadera Mikalor 70-90	Support mikalor 70-90	Collier mikalor 70-90	2306154
202	C. mandos termostato	Thermostat knob	Commande de thermostat	2309065

ST

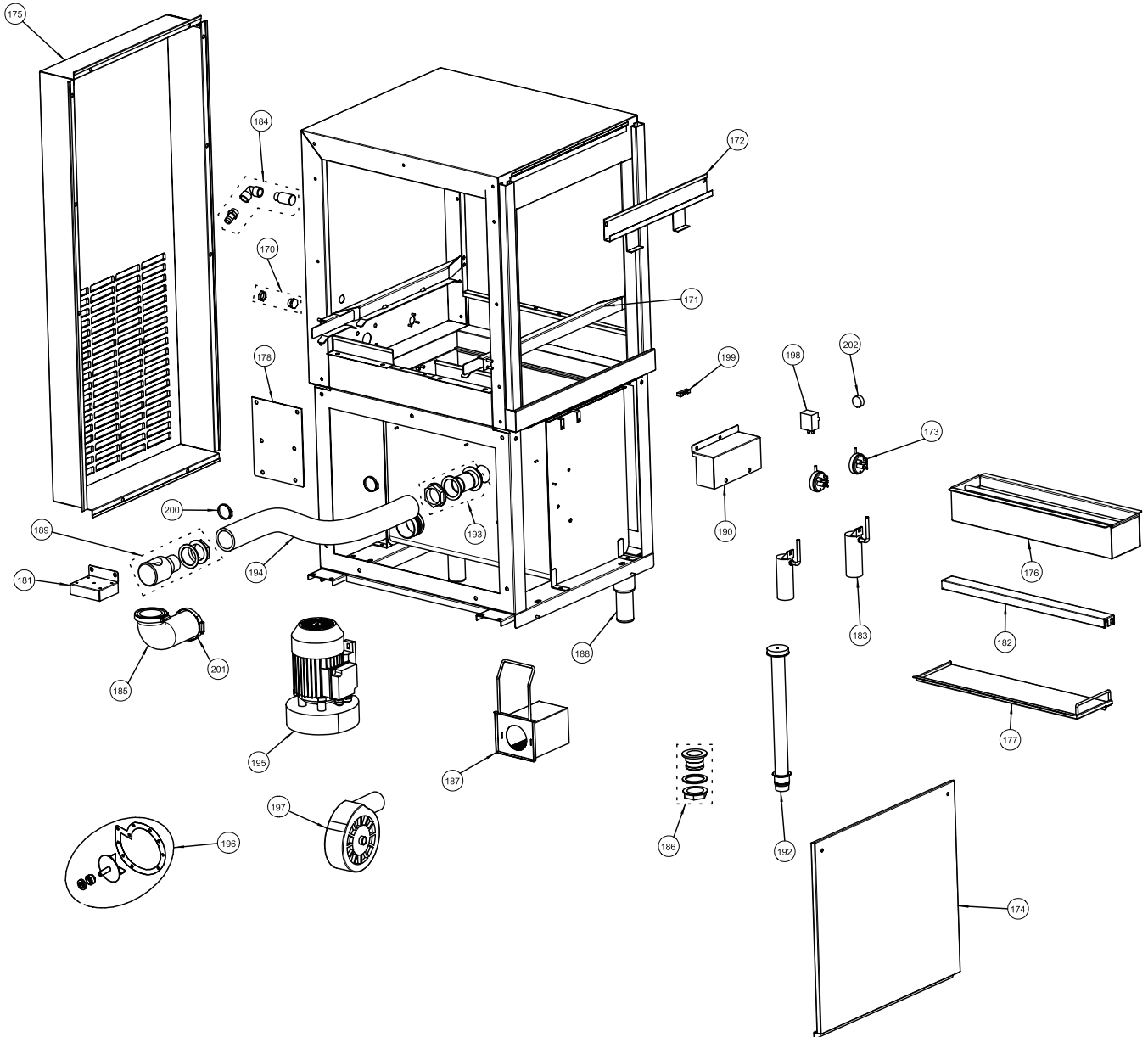

Nota: Todas estas especificaciones están sujetas a cambio sin previo aviso, debido a la permanente mejora del producto.  
 Note: These specifications are subject to change without notice due to continuous improvement.  
 Note: SAMMIC se réserve le droit de modifier et d'améliorer ses fabrications sans préavis.