

CM500RE SERVICE PARTS

This section contains the parts illustrations and parts lists for the CM500RE.

A "no number" designation, when found in the part number column, indicates the part in question is not available from Scotsman as an assembly. This designation is used only for clarity in making the list.

When ordering parts, to avoid costly delays and errors, give the part number, the complete description as shown in the list, and the quantity of each part or assembly required.

CM500R's have been manufactured in "C", "D" and "E" series (as in CM500RE-32E).

Check the complete model number to be certain of ordering the correct part.

TABLE OF CONTENTS

Exterior Panels	2
Interior Panels	3
Refrigeration	4
Water System	5
Control Box	6
Remote Condenser	7
Wiring Diagrams	8

CM500RE SERVICE PARTS

CABINET ASSEMBLY: D and E series. C series parts are obsolete

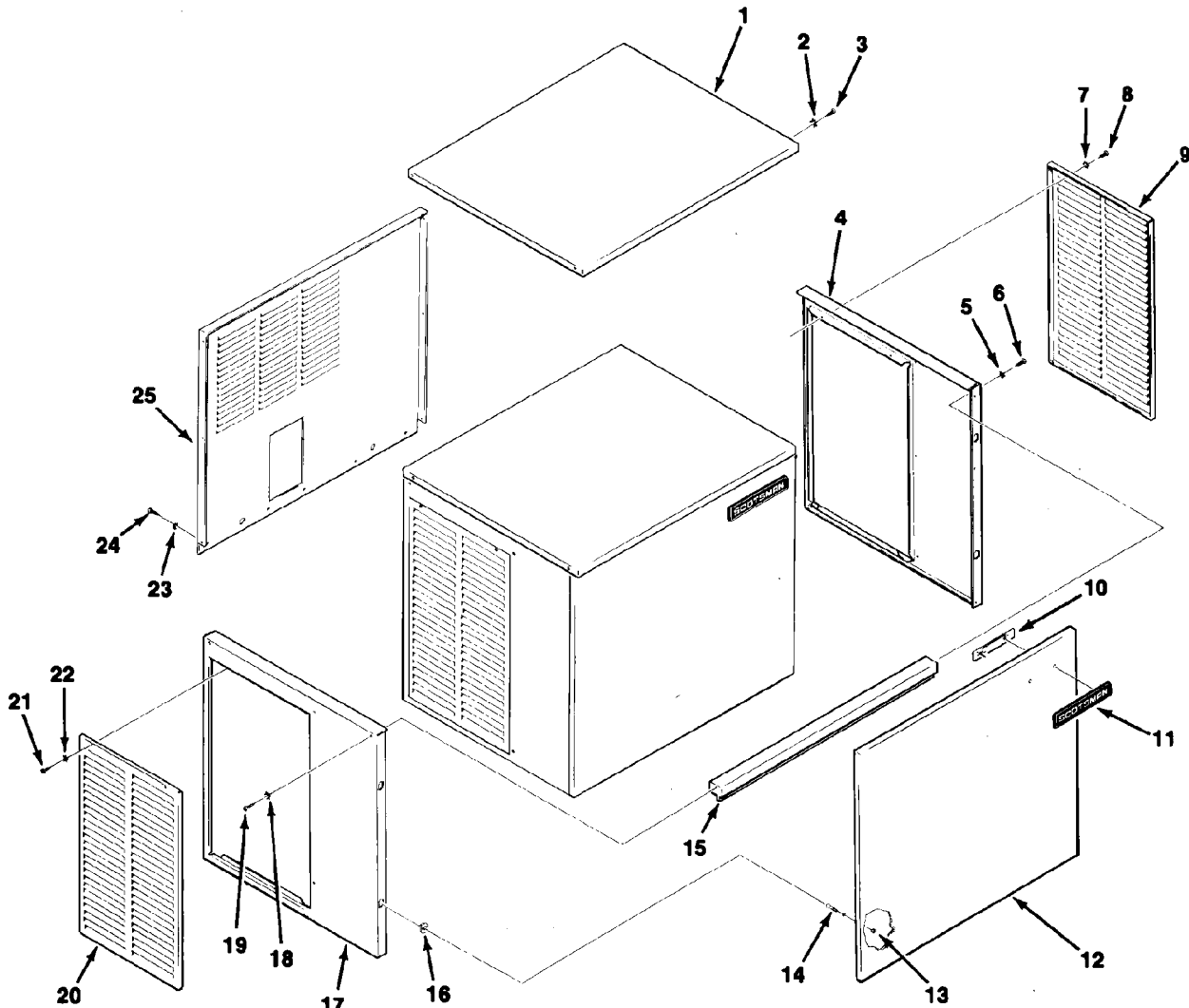

ITEM NUMBER	PART NUMBER	DESCRIPTION	ITEM NUMBER	PART NUMBER	DESCRIPTION
1	A32159-001	Top Panel, Painted	13	03-1406-04	Nut
	A32159-002	Top Panel, S. S.	14	15-0411-00	Strike
2	03-1417-03	Lockwasher	15	A32169-001	Front Support
3	03-1531-01	Screw	16	02-0836-00	Cabinet Catch
4	A32162-001	Right End Panel, Paint	17	A32163-001	Left End Panel, Paint
	A32162-002	Right End Panel, S.S.		A32163-002	Left End Panel, S.S.
5	03-1417-03	Lockwasher	18	03-1417-03	Lockwasher
6	03-1531-01	Screw	19	03-1531-01	Screw
7	03-1417-03	Lockwasher	20	A33946-001	Service Panel, sandalwood
8	03-1404-12	Screw		A33946-002	Service Panel, gray
9	A32161-001	Service Panel, Painted	Item 20 parts are plastic, fit late D and all E series		
	A32161-002	Service Panel, S.S.	21	03-1404-12	Screw
10	03-0271-00	Speed Nut	22	03-1412-03	Lockwasher
11	15-0711-01	Emblem	23	03-1417-03	Lockwasher
12	A32160-001	Front Panel, Painted	24	03-1531-01	Screw
	A32160-002	Front Panel, S.S.	25	A32201-001	Back Panel

CM500RE SERVICE PARTS

CABINET INTERIOR: D and E series. C series parts are obsolete.

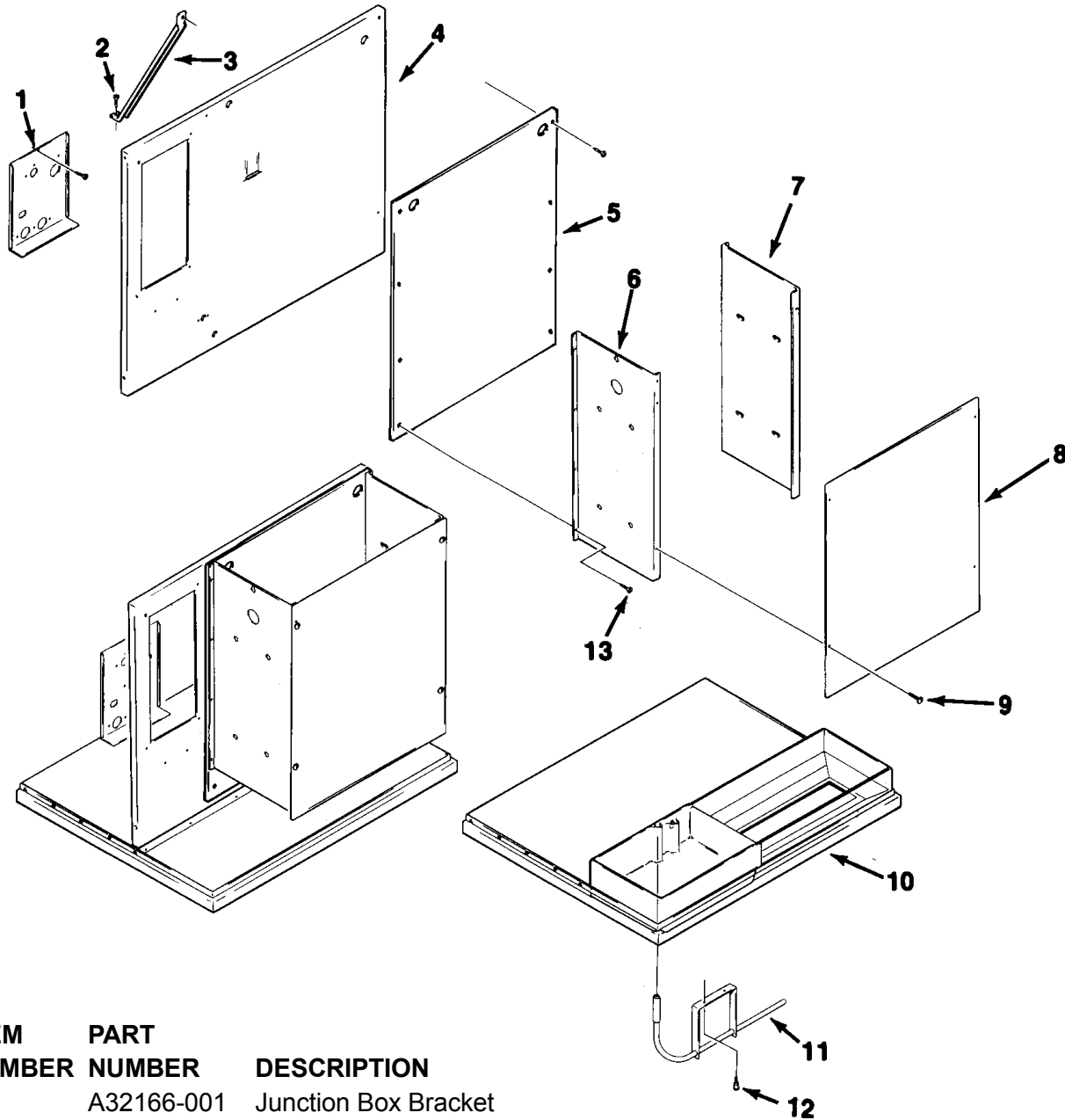

ITEM NUMBER	PART NUMBER	DESCRIPTION
1	A32166-001	Junction Box Bracket
2	03-1645-01	Screw
3	A32210-001	Support Brace
4	A32158-001	Retainer
5	02-2867-01	Splash Panel
6	A32172-001	Evaporator Bracket, Right
7	A32173-001	Evaporator Bracket, Left
8	A32165-001	Evaporator Plate Cover
9	03-0727-09	Thumbscrew
10	A32153-001	Base
11	A32262-001	Bin Thermostat Bracket
12	03-0727-09	Thumbscrew
13	03-1531-02	Screw

CM500RE SERVICE PARTS REFRIGERATION SYSTEM

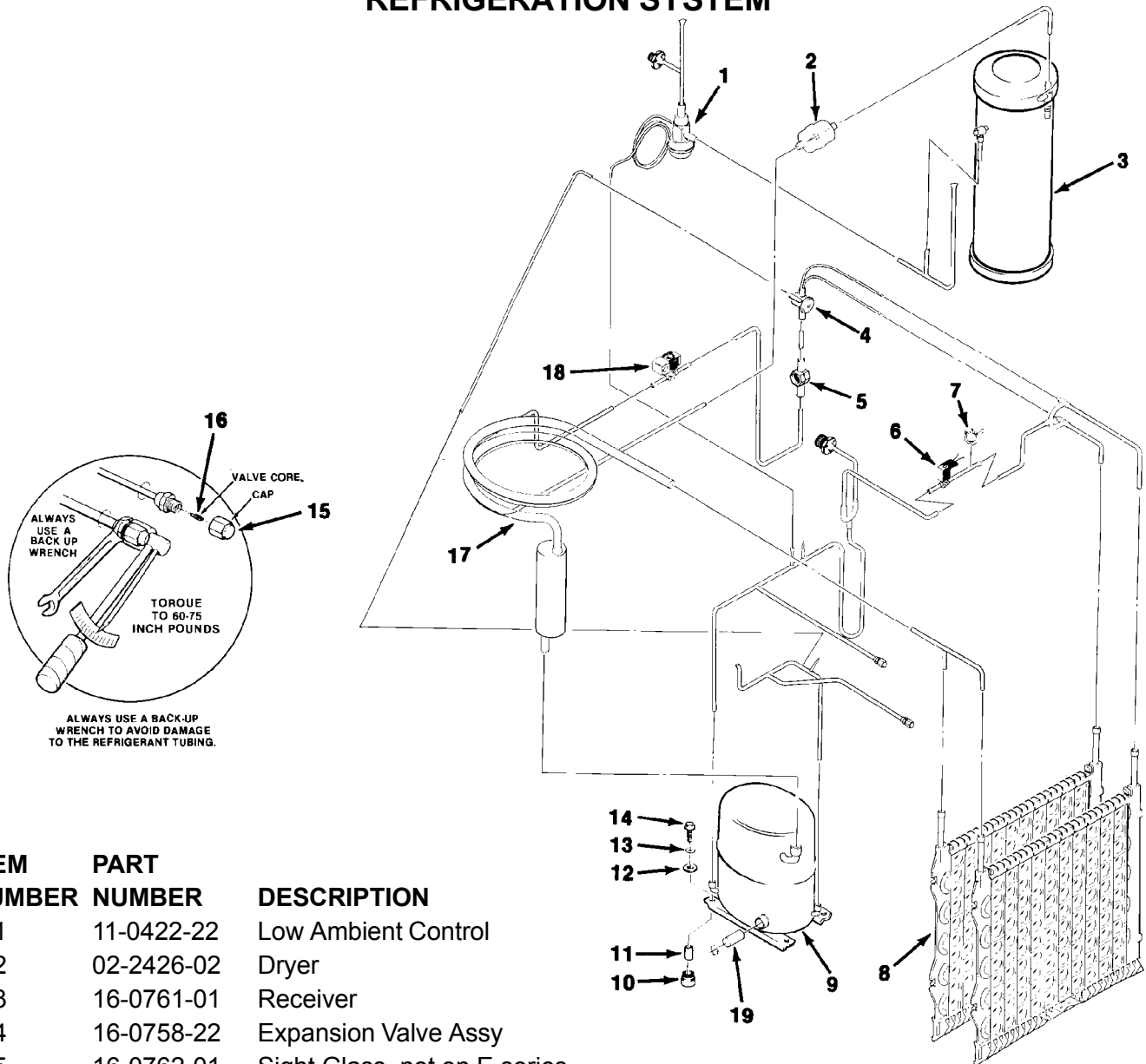

ITEM NUMBER	PART NUMBER	DESCRIPTION
1	11-0422-22	Low Ambient Control
2	02-2426-02	Dryer
3	16-0761-01	Receiver
4	16-0758-22	Expansion Valve Assy
5	16-0762-01	Sight Glass, not on E series.
6	12-2257-22	Hot Gas Valve
7	12-2300-03	Hi Temperature Cut Out
8	A30296-020	Evaporator Plate
9	18-6100-01	Compressor 115/60/1. C-D series
	18-6100-50	Overload for compressor
	18-8711-01	Compressor 115/60/1. E series
	18-8711-50	Overload for compressor
10	18-6800-01	Mounting Grommet
11	18-2300-26	Sleeve
12	03-1407-07	Washer, 5/16
13	no number	Washer
14	03-1405-20	Screw, 5/16-18
15	16-0563-00	Valve Cap
16	15-0560-00	Valve Core

ITEM NUMBER	PART NUMBER	DESCRIPTION
17	A31132-020	Heat exchanger. C series
	A33205-020	Heat Exch. D and E series
18	12-2274-02	Liquid Line Solenoid Valve
19	18-1868-01	Crankcase Heater

CM500RE SERVICE PARTS

WATER SYSTEM

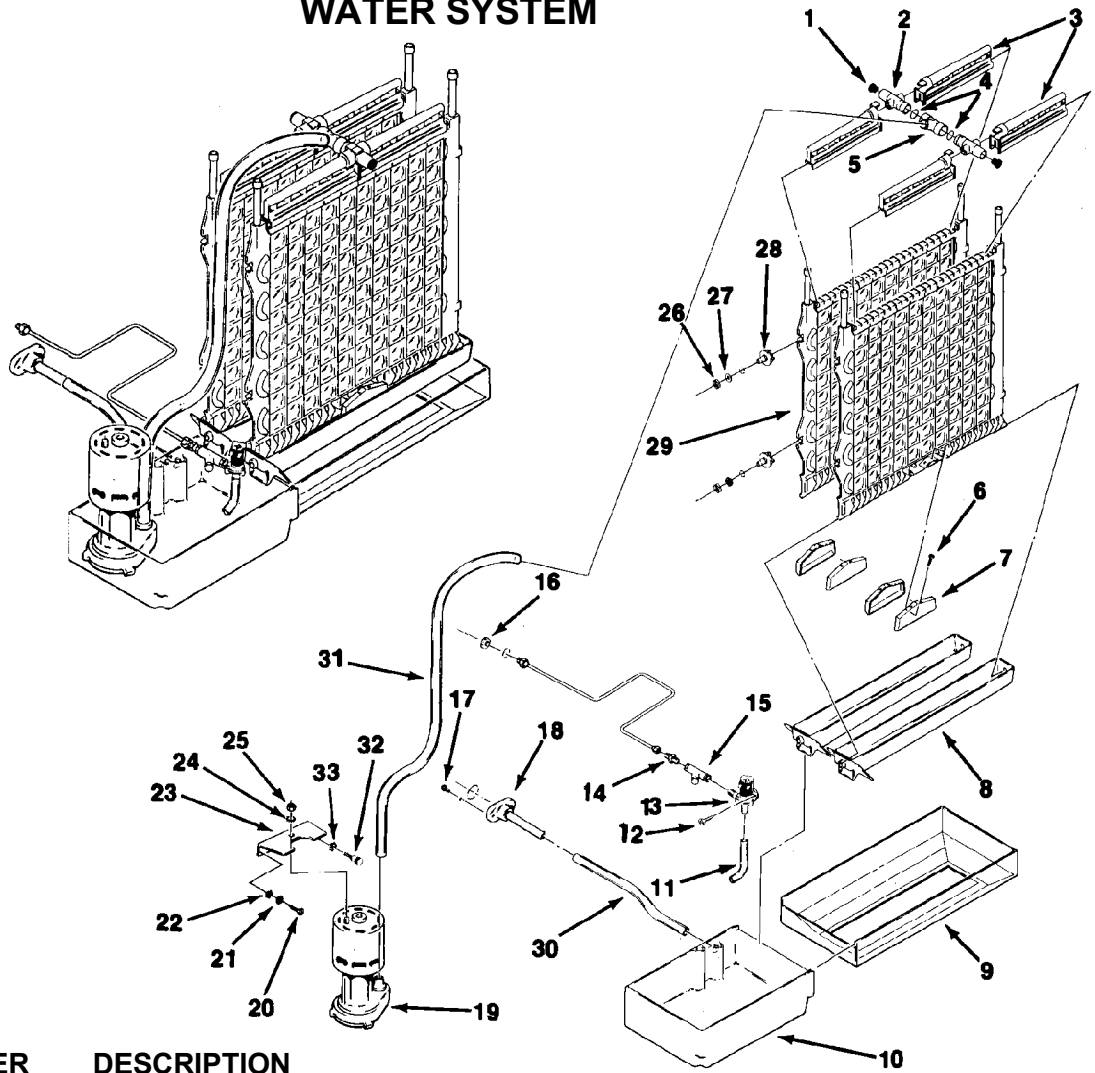

ITEM NUMBER	PART NUMBER	DESCRIPTION
1	13-0840-01	Manifold Plug
2	A29703-001	Manifold Water Tube
3	02-2527-01	Water Distrib. Tube
4	13-0617-48	O-Ring (2)
5	02-2519-01	Plastic Tee
6	03-1404-10	Screw
7	02-2878-01	Sump End Cover
8	02-2868-01	Drain Trough
9	no number	Cube Chute
10	02-2812-01	Sump for C series
	02-2869-01	Sump for all others
11	A30918-001	Sump Inlet Tube C thru early E
12	03-1531-01	Screw
13	12-2201-04	Solenoid Valve C series
	12-2313-04	Solenoid valve, for D and E series
14	16-0791-01	Half Union
15	16-0162-00	Stainer D and early E series only
16	03-1394-01	Pal Nut

ITEM NUMBER	PART NUMBER	DESCRIPTION
17	03-1645-01	Screw
18	A32282-003	Drain Assembly
19	12-2265-21	Water Pump Assembly
20	03-1403-17	Screw
21	03-1407-03	Washer
22	03-1408-31	Washer
23	A30914-002	Pump Mounting Bracket
24	03-1417-05	Lockwasher
25	03-1406-05	Nut
26	03-1394-03	Pal Nut
27	03-1408-34	Special Washer
28	02-2642-01	Plate Mount
29	A30296-020	Evaporator
30	13-0674-07	Drain Hose, 8"
31	13-0674-07	Pump Hose, 33"
32	03-0727-09	Thumbscrew
33	03-1417-03	Lockwasher

CM500RE SERVICE PARTS

CONTROL BOX

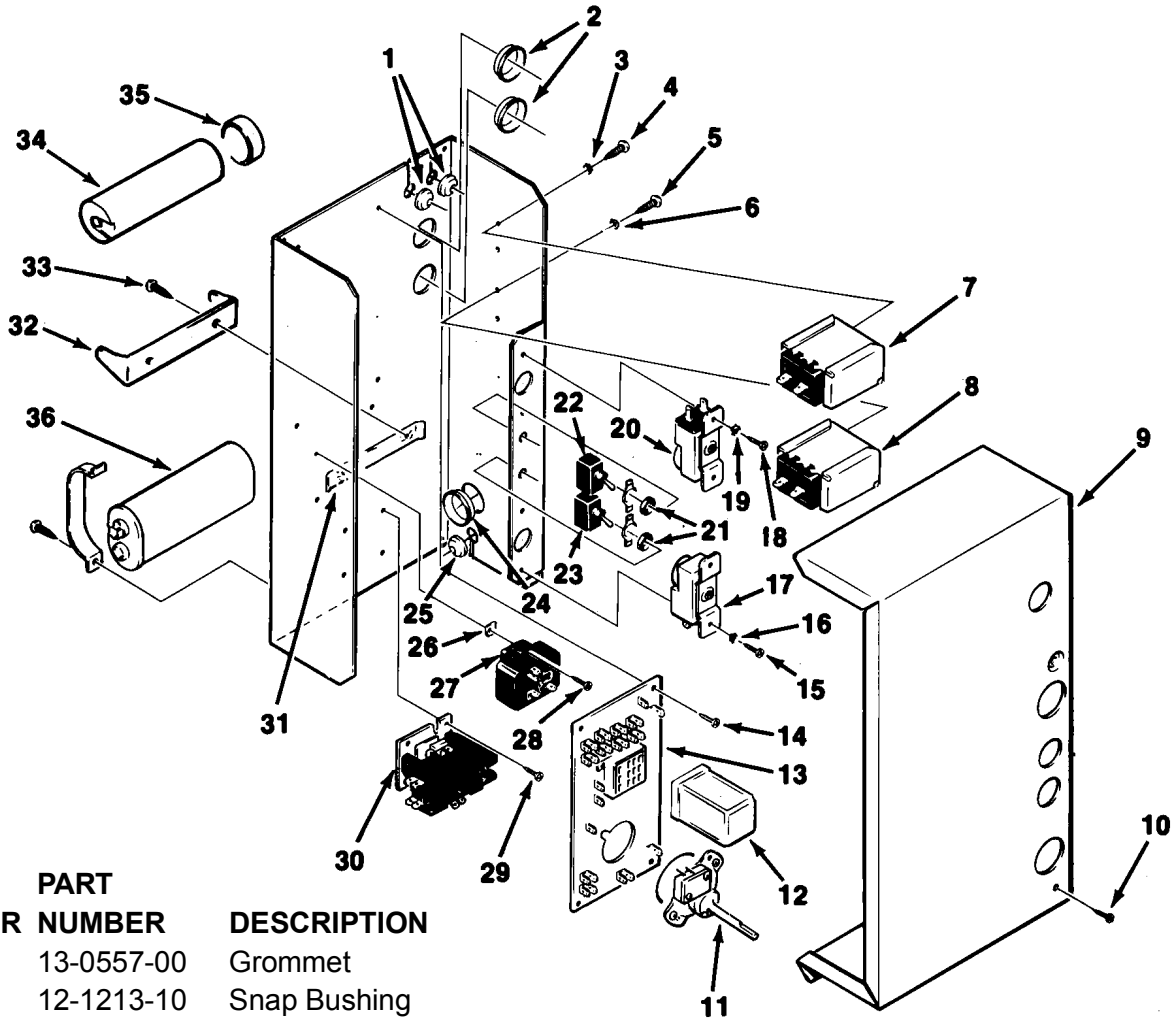

ITEM NUMBER	PART NUMBER	DESCRIPTION
1	13-0557-00	Grommet
2	12-1213-10	Snap Bushing
3	03-1417-18	Lockwasher
4	03-1403-02	Screw
5	03-1403-02	Screw
6	03-1417-18	Lockwasher
7	11-0420-21	Low Press Control Sw
8	11-0429-21	High Press. Safety Sw.
9	A32168-001	Control Box Cover
10	03-1531-01	Screw
11	12-1980-21	Timer & Switch
12	12-1879-02	Relay, 115 V
13	12-1912-01	Circuit Board
14	03-1403-02	Screw
15	03-1403-05	Screw
16	03-1417-03	Lockwasher
17	11-0427-22	Bin Thermostat
18	03-1403-05	Screw
19	03-1417-03	Lockwasher
20	11-0435-21	Cube Size Control
21	03-1417-16	Lockwasher

ITEM NUMBER	PART NUMBER	DESCRIPTION
22	12-2255-01	Switch
23	12-0426-01	Switch
24	12-1213-17	Snap Bushing
25	13-0557-00	Grommet
26	03-1423-01	Speed Nut
27	18-1903-44	Potential Relay C & D series
	18-1903-50	Potential relay, E series
28	03-1403-02	Screw
29	03-1403-15	Screw
30	12-2469-03	Contactor,
31	03-1103-00	Twin Speed Nut
32	18-2200-39	Start Capacitor Bracket
33	03-1403-15	Screw
34	18-1901-42	Start Capacitor C & D series
	18-1901-03	Start Capacitor, E series
35	18-2200-38	Start Capacitor Cap.
36	18-1902-45	Run Capacitor, E series only

CM500RE SERVICE PARTS

REMOTE CONDENSER

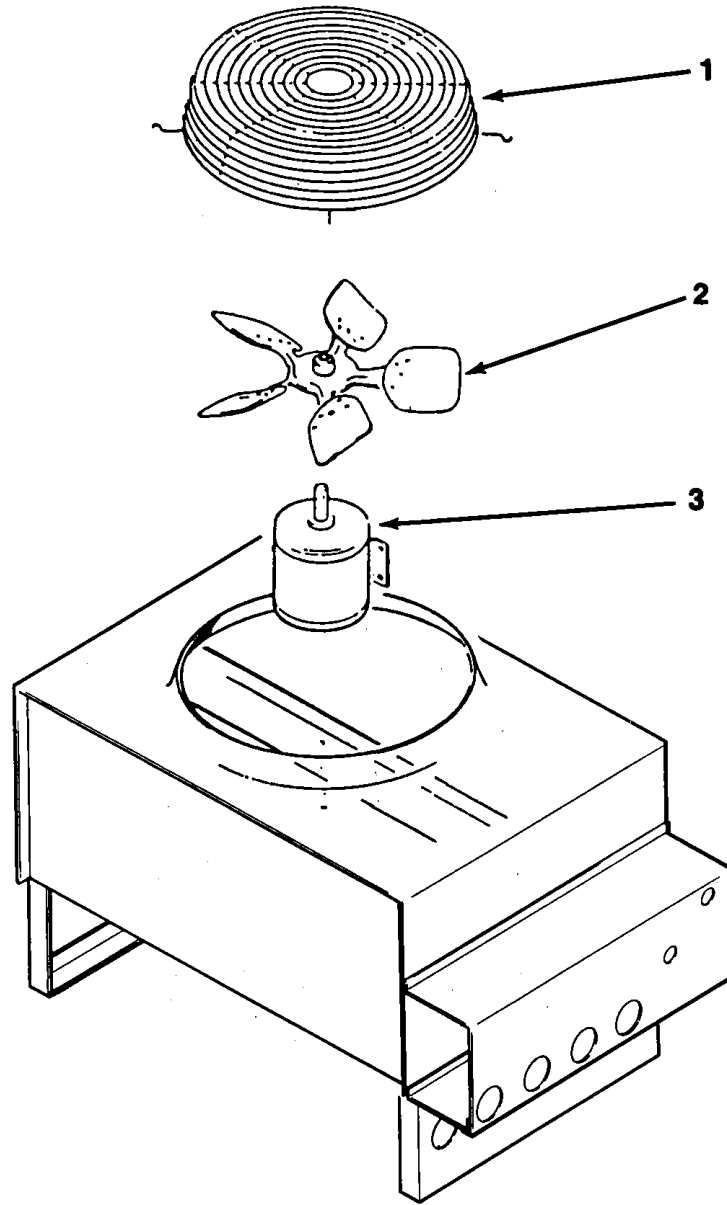

RC551

ITEM NUMBER	PART NUMBER	DESCRIPTION
1	02-2618-01	Fan Guard
2	18-3733-01	Fan Blade
3	18-6305-01	Fan Motor

A31914-001

THIS UNIT SHOWN IN THE
TIMED PORTION OF
THE FREEZING CYCLE

Wiring Diagram CM500R-1D

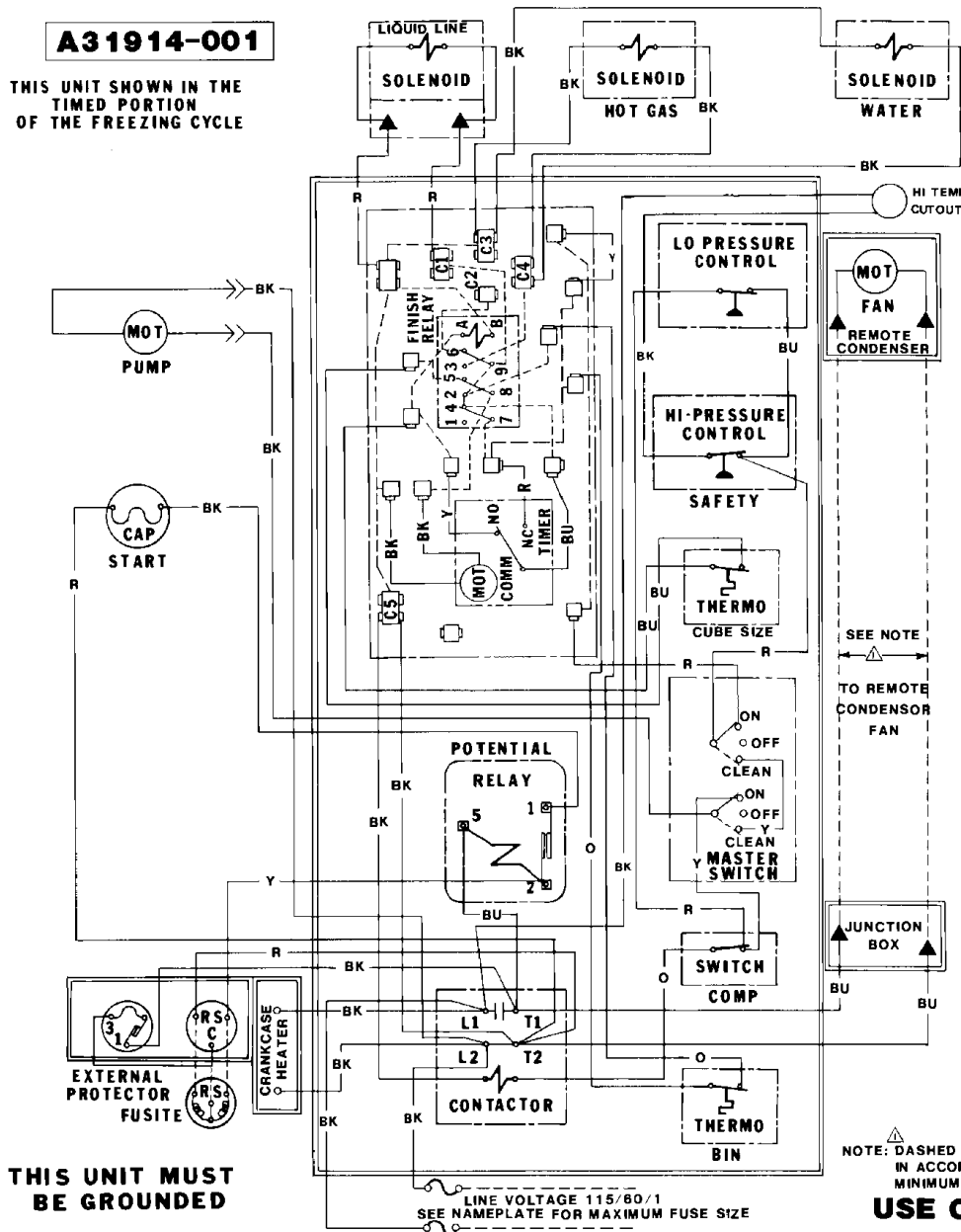

**THIS UNIT MUST
BE GROUNDED**

LINE VOLTAGE 115/60/1
SEE NAMEPLATE FOR MAXIMUM FUSE SIZE

CAUTION:

MORE THAN ONE DISCONNECT MEANS
MAY BE REQUIRED TO DISCONNECT ALL
POWER TO THIS UNIT

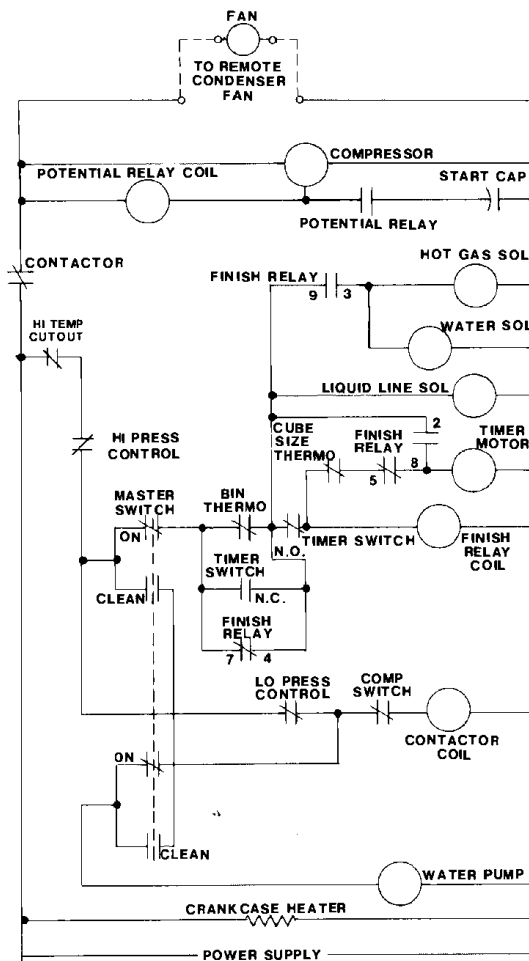

NOTE: DASHED LINES INDICATE FIELD WIRING WHICH MUST BE INSTALLED
IN ACCORDANCE WITH THE NATIONAL ELECTRICAL CODE USING A
MINIMUM OF 14 GA AWG WIRE.

USE COPPER CONDUCTORS ONLY

CM500RE SERVICE PARTS

A32109-001

THIS UNIT SHOWN IN THE
TIMED PORTION
OF THE FREEZING CYCLE

Wiring Diagram CM500R-1D

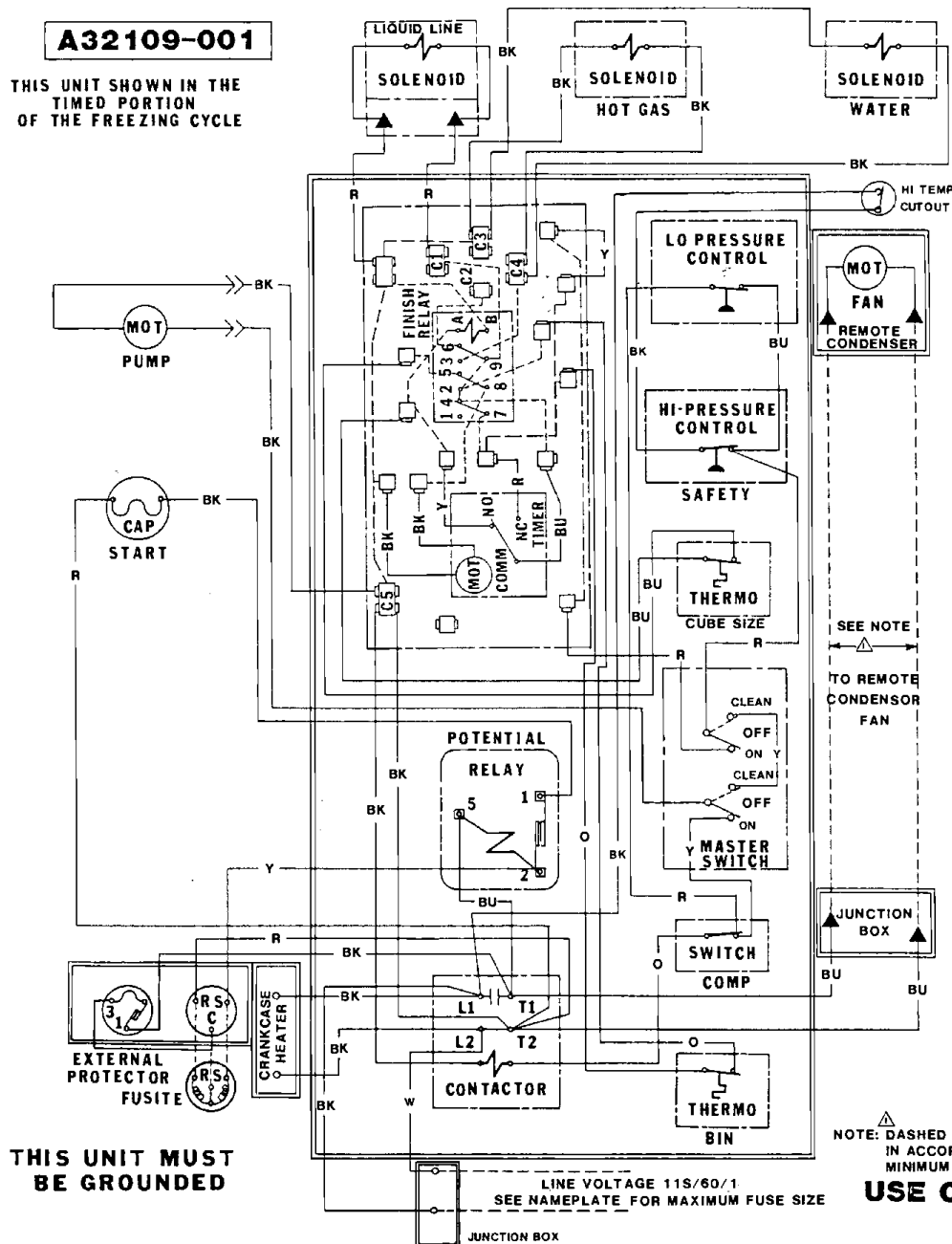

**THIS UNIT MUST
BE GROUND**

LINE VOLTAGE 115/60/1
SEE NAMEPLATE FOR MAXIMUM FUSE SIZE

JUNCTION BOX

CAUTION:

MORE THAN ONE DISCONNECT MEANS
MAY BE REQUIRED TO DISCONNECT ALL
POWER TO THIS UNIT

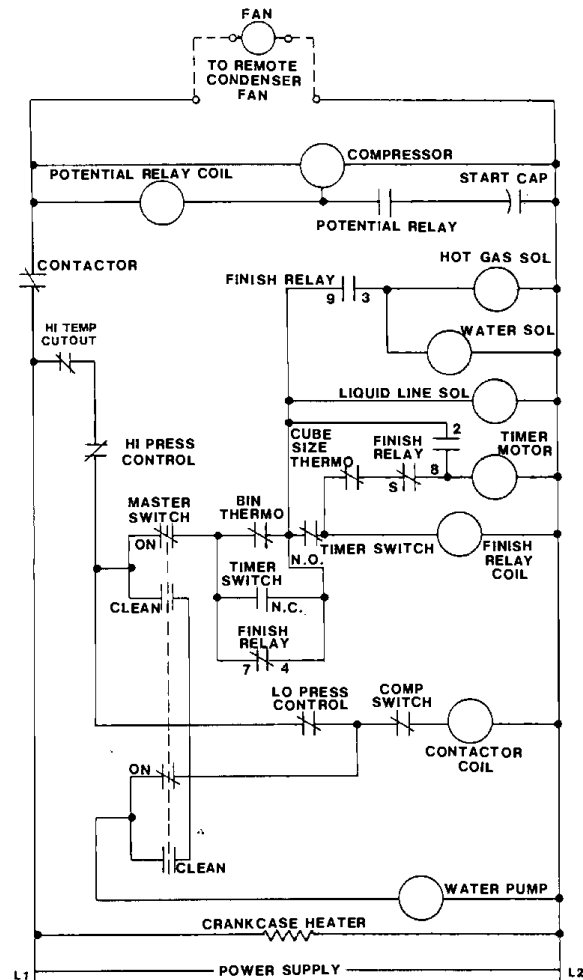

NOTE: DASHED LINES INDICATE FIELD WIRING WHICH MUST BE INSTALLED
IN ACCORDANCE WITH THE NATIONAL ELECTRICAL CODE USING A
MINIMUM OF 14 GA AWG WIRE.

USE COPPER CONDUCTORS ONLY

CM500RE SERVICE PARTS

CM500RE SERVICE PARTS

CM500RE-1E Wiring Diagram

A35538-001

THIS UNIT MUST BE GROUNDED

CAUTION:
MORE THAN ONE DISCONNECT
MEANS MAY BE REQUIRED
TO DISCONNECT ALL POWER
TO THIS UNIT

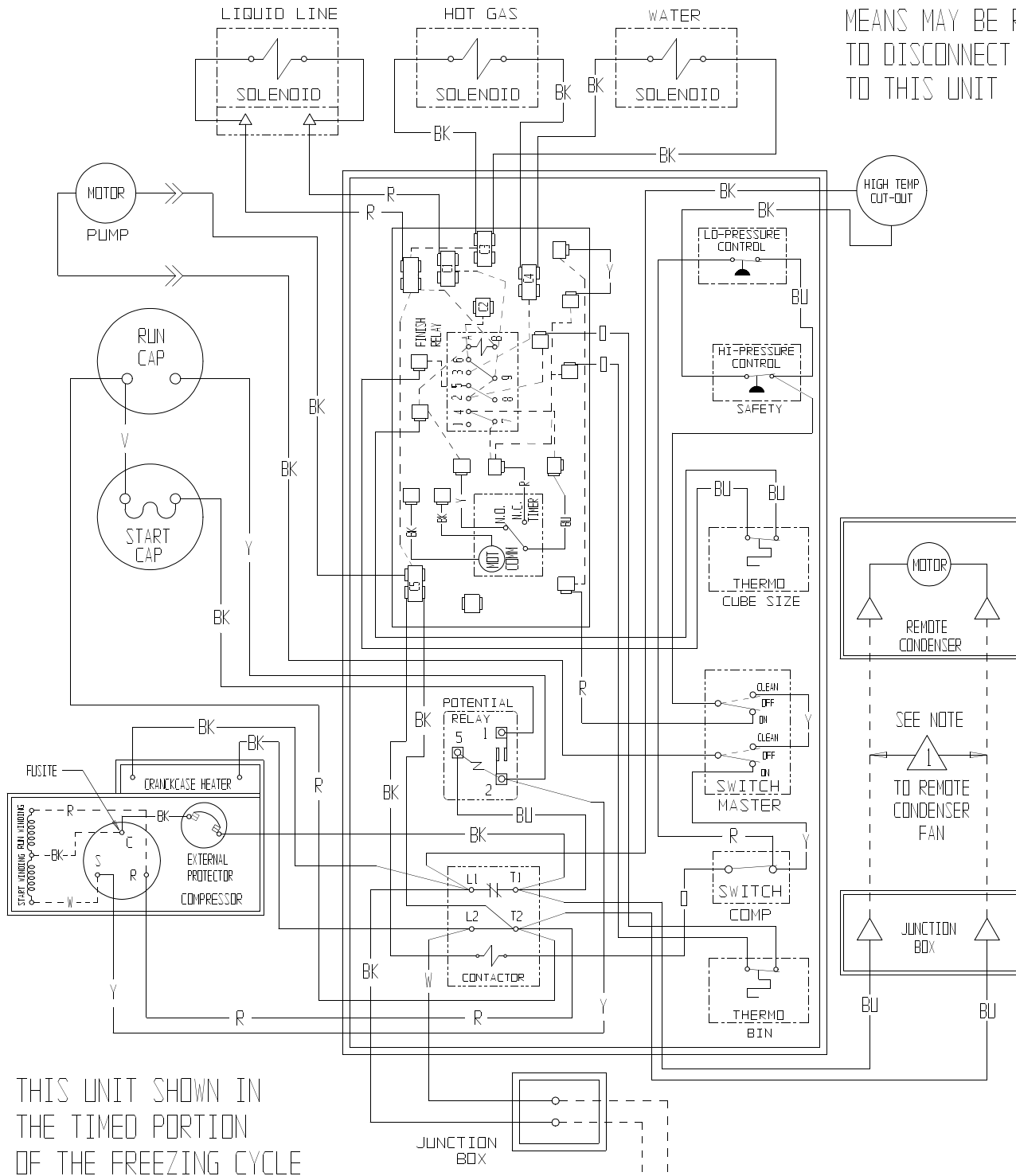

THIS UNIT SHOWN IN
THE TIMED PORTION
OF THE FREEZING CYCLE

LINE VOLTAGE 115/60/1
SEE NAMEPLATE FOR MAXIMUM FUSE SIZE

USE COPPER CONDUCTORS ONLY

 NOTE: DASHED LINES INDICATE FIELD WIRING WHICH MUST BE INSTALLED IN ACCORDANCE WITH THE NATIONAL ELECTRICAL CODE AND ALL STATE AND LOCAL CODES USING A MINIMUM OF 14 GA AWG WIRE.

CM500RE SERVICE PARTS

CM500RE-1E Wiring Diagram

CAUTION:
 MORE THAN ONE DISCONNECT
 MEANS MAY BE REQUIRED
 TO DISCONNECT ALL POWER
 TO THIS UNIT

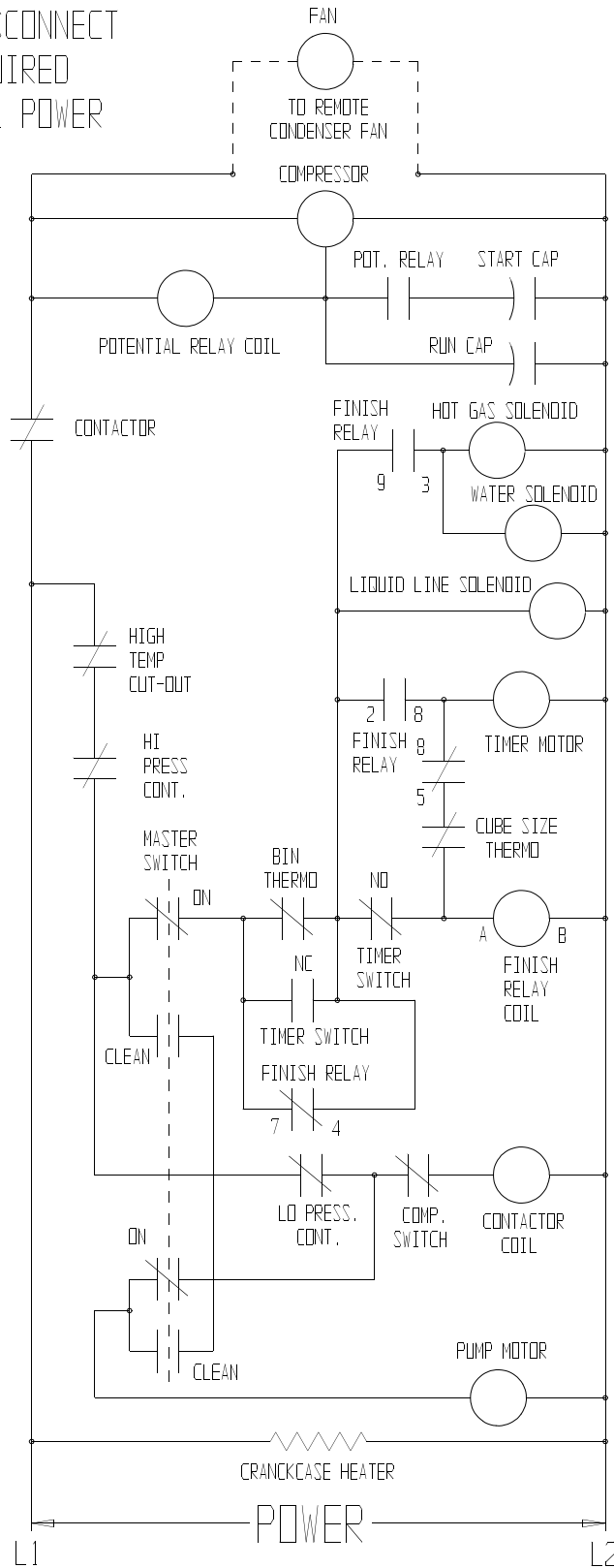

NOTE: DASHED LINES INDICATE FIELD WIRING WHICH MUST BE INSTALLED IN ACCORDANCE WITH THE NATIONAL ELECTRICAL CODE AND ALL STATE AND LOCAL CODES USING A MINIMUM OF 14 GA AWG WIRE.