

CM650 Parts List

Table of Contents

Cabinet Exterior

Cabinet Interior

Air Cooled Refrigeration

Water Cooled Refrigeration

Water System

Control Box

Wiring Diagrams

CM650E SERVICE PARTS

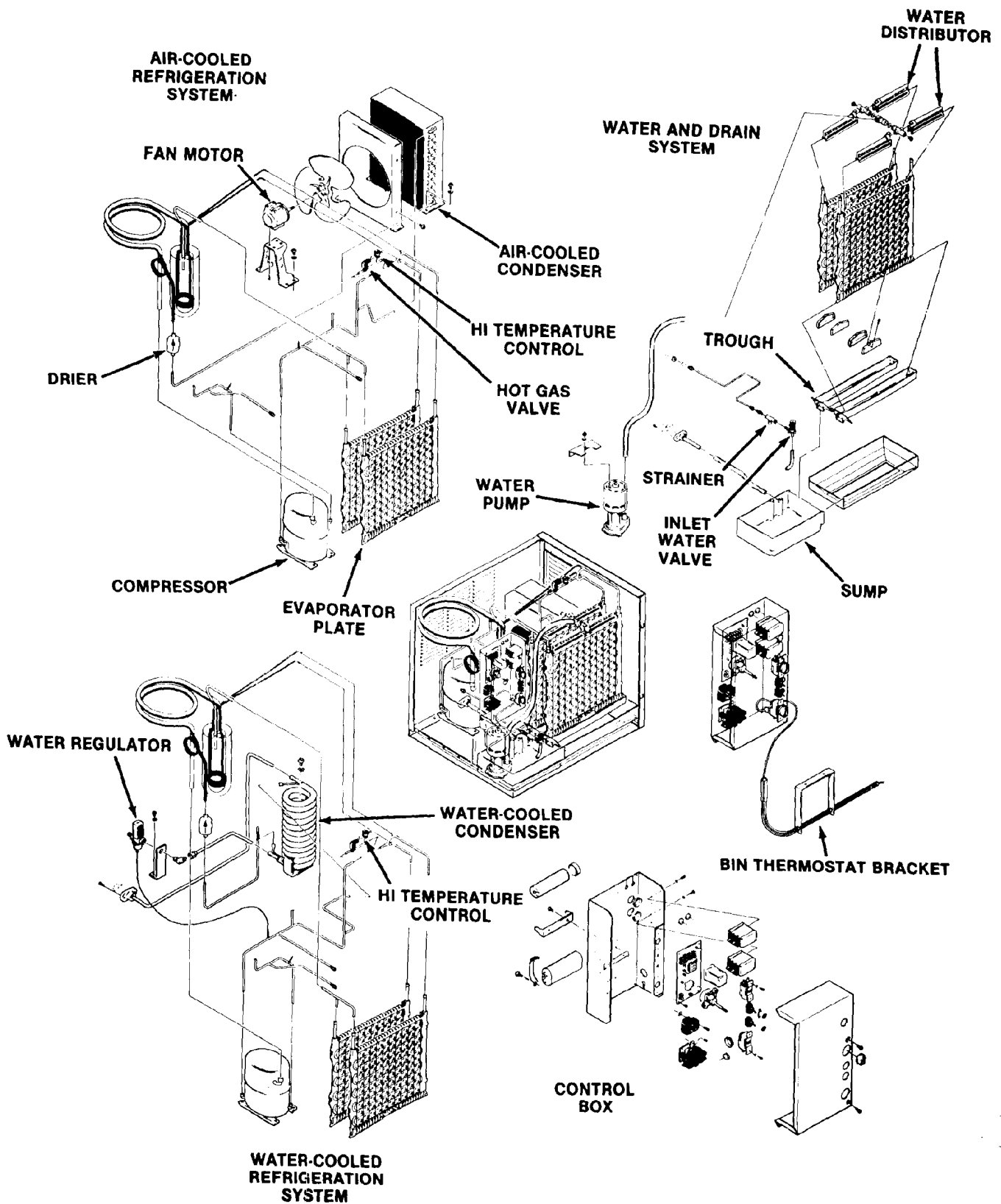

CM650E SERVICE PARTS

CABINET ASSEMBLY

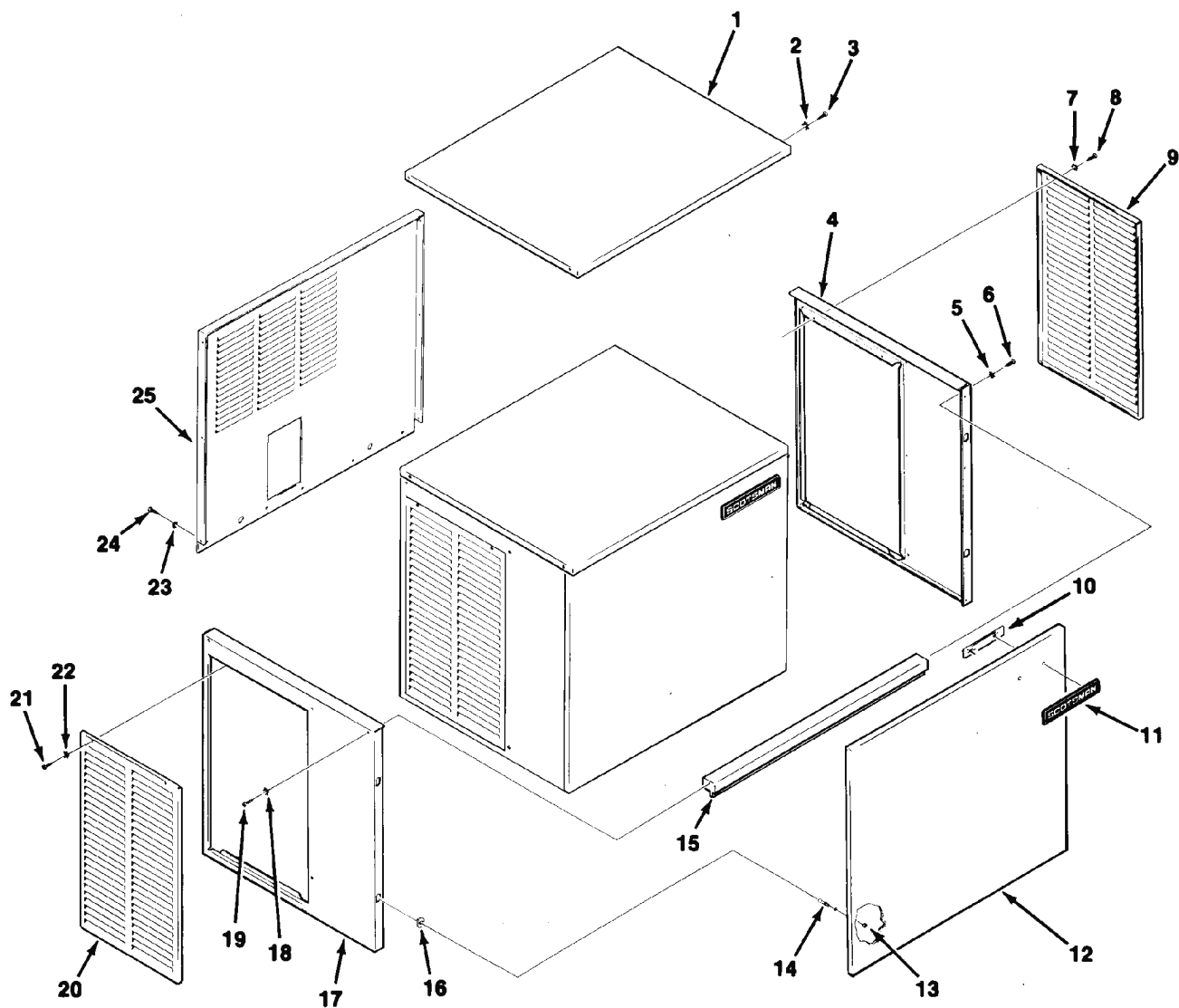

ITEM NUMBER	PART NUMBER	DESCRIPTION	ITEM NUMBER	PART NUMBER	DESCRIPTION
1	A32159-001	Top Panel, Painted	13	03-1406-04	Nut
	A32159-002	Top Panel, S. S.	14	15-0411-00	Strike
2	03-1417-03	Lockwasher	15	A32169-001	Front Support
3	03-1531-01	Screw	16	02-0836-00	Cabinet Catch
4	A32162-001	Right End Panel, Paint	17	A32163-001	Left End Panel, Paint
	A32162-002	Right End Panel, S.S.		A32163-002	Left End Panel, S.S.
5.	03-1417-03	Lockwasher	18	03-1417-03	Lockwasher
6	03-1531-01	Screw	19	03-1531-01	Screw
7	03-1417-03	Lockwasher	20	A32161-001	Service Panel, Paint
8	03-1404-12	Screw		A32161-002	Service Panel, S.S.
9	A32161-001	Service Panel, Painted	21	03-1404-12	Screw
	A32161-002	Service Panel, S.S.	22	03-1412-03	Lockwasher
10	03-0271-00	Speed Nut	23	03-1417-03	Lockwasher
11	15-0711-01	Emblem	24	03-1531-01	Screw
12	A32160-001	Front Panel, Painted	25	A32202-003	Back Panel
	A32160-002	Front Panel, S.S.			

CM650E SERVICE PARTS

CABINET INTERIOR

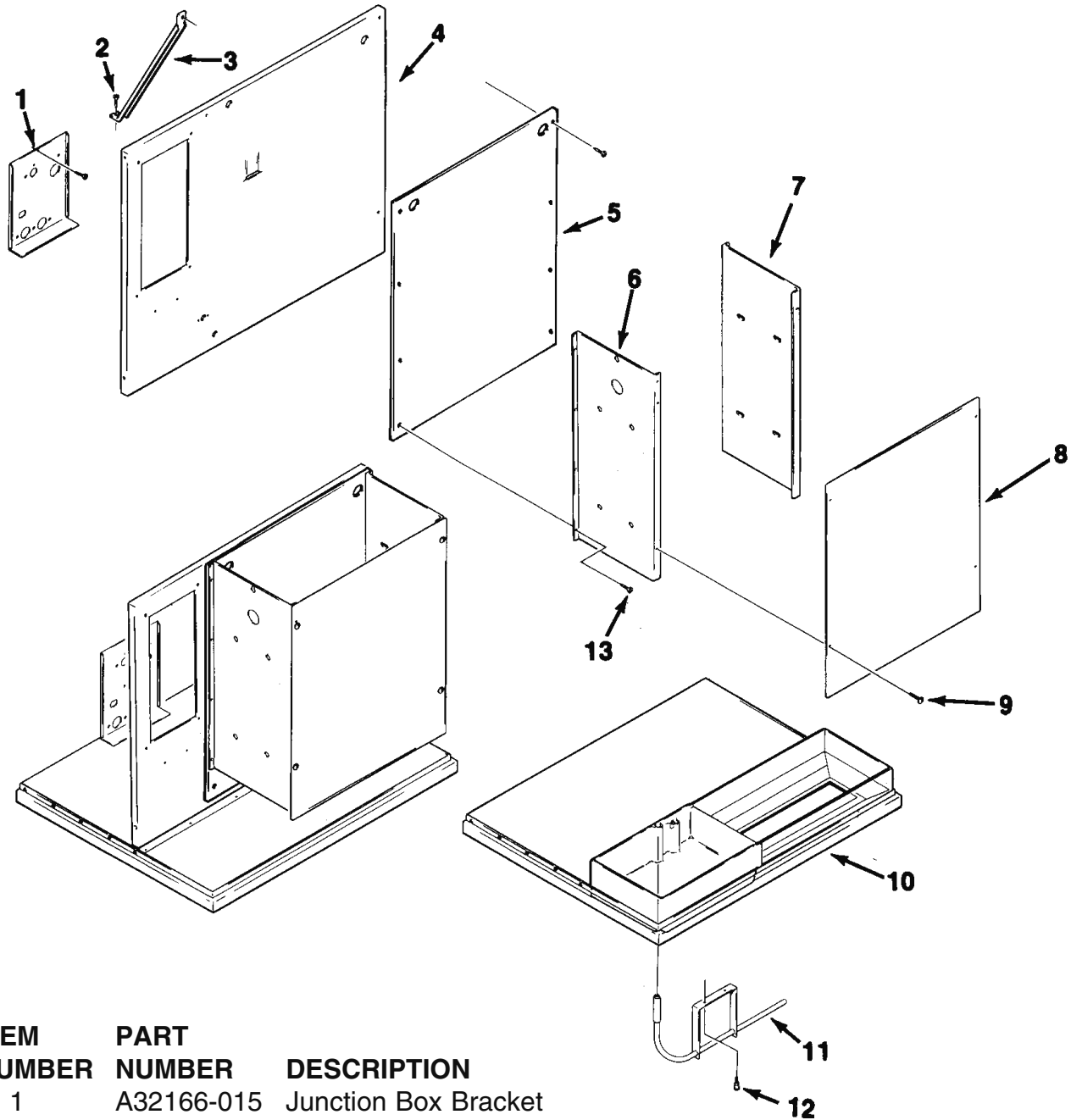

ITEM NUMBER	PART NUMBER	DESCRIPTION
1	A32166-015	Junction Box Bracket
2	03-1645-01	Screw
3	A32210-001	Support Brace
4	A32158-001	Retainer
5	02-2867-01	Splash Panel
6	A32172-001	Evaporator Bracket, Right
7	A32173-001	Evaporator Bracket, Left
8	02-3246-01	Evaporator Plate Cover
9	03-0727-09	Thumbscrew
10	A32153-001	Base
11	A32262-001	Bin Thermostat Bracket
12	03-0727-09	Thumbscrew
13	03-1531-02	Screw

CM650E SERVICE PARTS

AIR COOLED REFRIGERATION

Note: In the original parts list for the CM650E, the part numbers for items 3 and 11 were **WRONG**. Here are the correct part numbers.

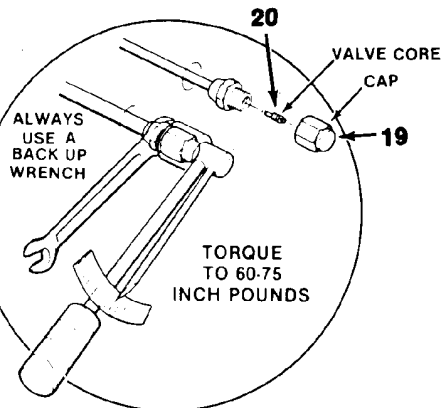
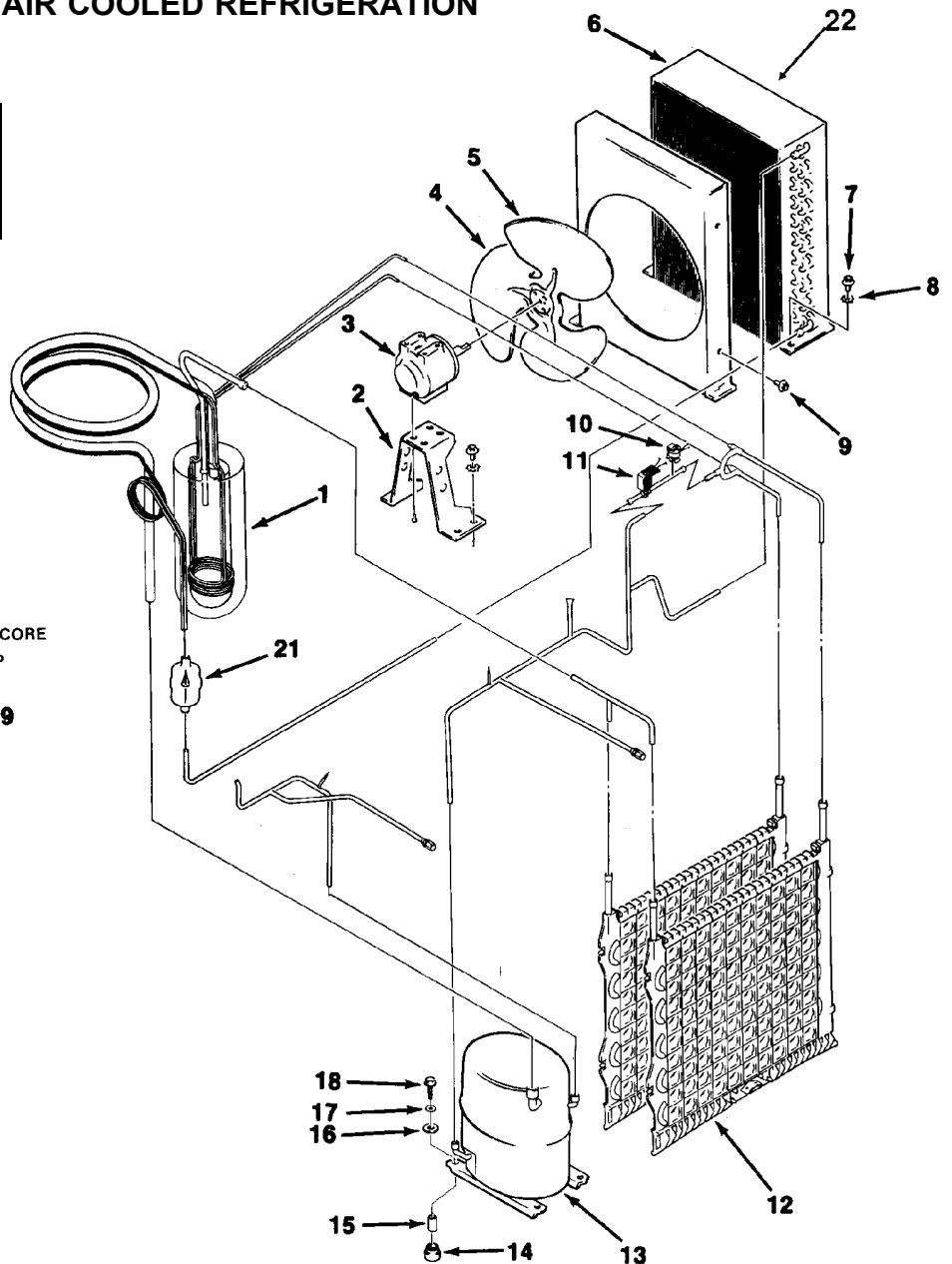

ALWAYS USE A BACK-UP WRENCH TO AVOID DAMAGE TO THE REFRIGERANT TUBING.

ITEM NUMBER	PART NUMBER	DESCRIPTION	ITEM NUMBER	PART NUMBER	DESCRIPTION
1	A32174-020	Heat Exchanger	13	18-8879-21	Compressor (203-230/60/1)
2	18-3739-01	Fan Motor Bracket		18-8879-22	Compressor (208-230/60/3)
3	18-5105-02	Fan Motor			(Both have an internal overload)
4	18-3732-01	Fan Blade	14	18-6800-01	Grommet
5	A32170-001	Fan Shroud	15	18-2300-26	Sleeve
6	18-3709-01	Condenser	16	03-1407-07	Washer
7	03-1645-01	Screw	17	no number	washer
8	03-1410-03	Lockwasher	18	03-1405-20	Screw
	03-1407-05	Washer	19	16-0563-00	Cap
9	03-1531-01	Screw	20	16-0560-00	Core
10	12-2300-03	Hi Temp Cut Out	21	02-3319-01	Drier
11	12-2135-22	Hot Gas Valve	22	A32975-001	Foam Filter
12	A30296-020	Evaporator			

CM650E SERVICE PARTS

WATER COOLED REFRIGERATION

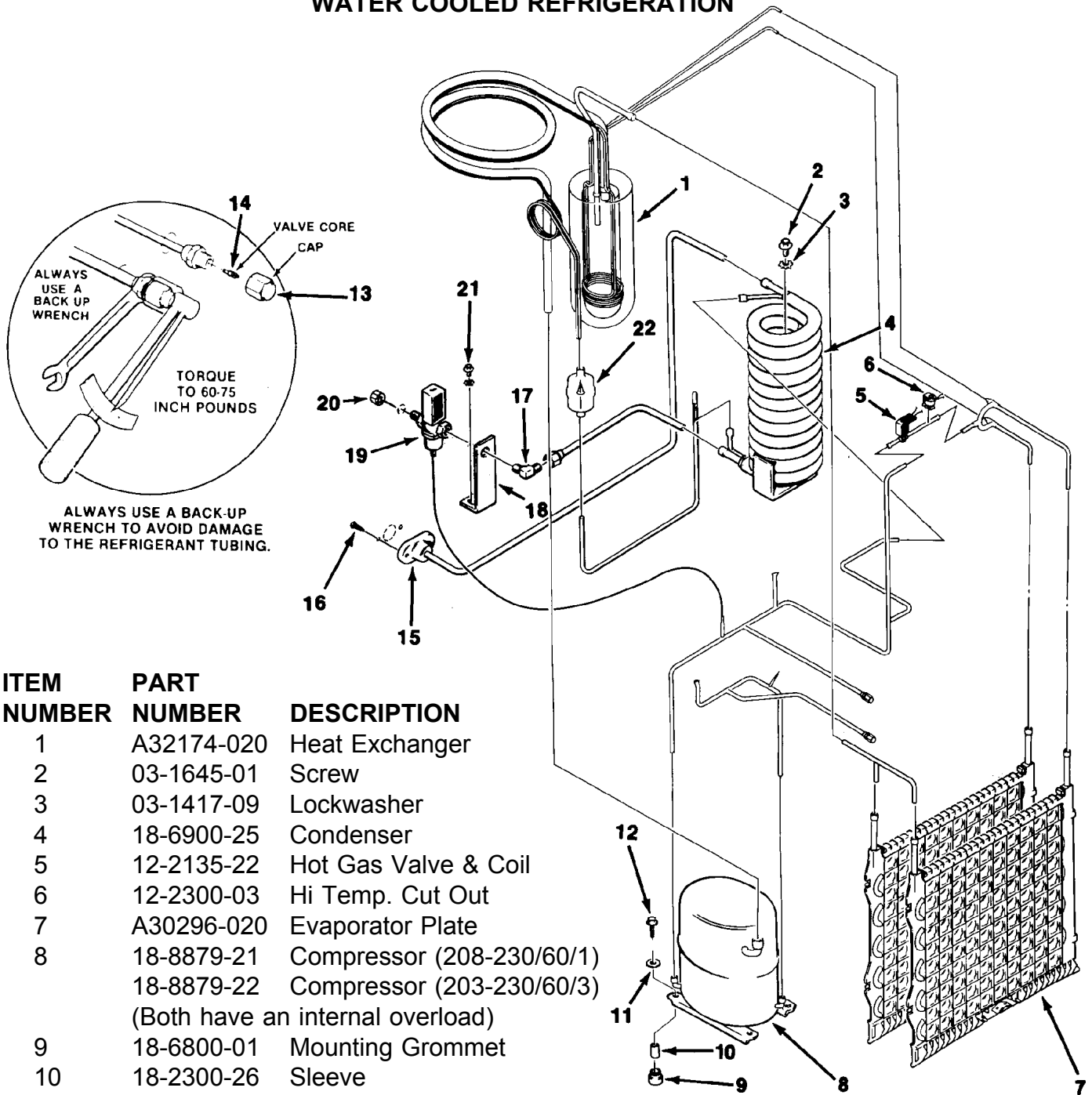

ITEM NUMBER	PART NUMBER	DESCRIPTION
1	A32174-020	Heat Exchanger
2	03-1645-01	Screw
3	03-1417-09	Lockwasher
4	18-6900-25	Condenser
5	12-2135-22	Hot Gas Valve & Coil
6	12-2300-03	Hi Temp. Cut Out
7	A30296-020	Evaporator Plate
8	18-8879-21	Compressor (208-230/60/1)
	18-8879-22	Compressor (203-230/60/3)
		(Both have an internal overload)
9	18-6800-01	Mounting Grommet
10	18-2300-26	Sleeve
11	03-1407-07	Washer
12	03-1405-20	Screw
13	16-0563-00	Valve Cap
14	16-0560-00	Valve Core
15	A33363-001	Drain Fab Assembly
16	03-1403-14	Screw
17	16-0401-02	Brass Elbow
18	no number	Bracket
19	11-0424-01	Water Reg. Valve
20	03-1394-01	Pal Nut
21	03-1403-14	Screw
22	02-3319-02	Filter Drier

CM650E SERVICE PARTS

WATER SYSTEM

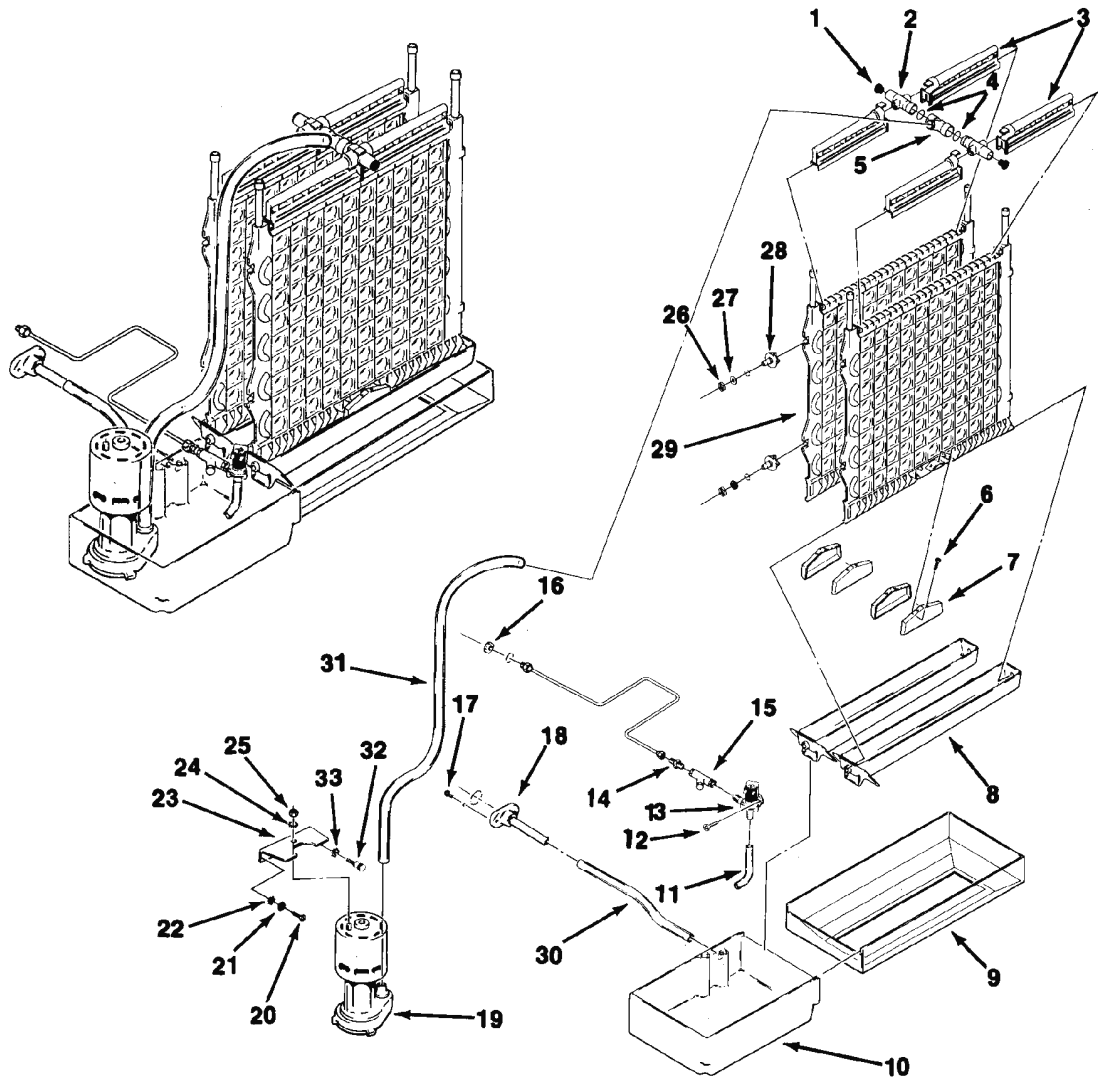

ITEM NUMBER	PART NUMBER	DESCRIPTION	ITEM NUMBER	PART NUMBER	DESCRIPTION
1	13-0840-01	Manifold Plug	18	A32282-003	Drain Ass. (Air Cooled)
2	A29703-001	Manifold Water Tube	19	12-2265-22	Water Pump Assembly
3	02-2527-01	Water Distrib. Tube	20	03-1403-17	Screw
4	13-0617-48	O-Ring (2)	21	03-1407-03	Washer
5	02-2519-01	Plastic Tee	22	03-1408-31	Washer
6	03-1404-10	Screw	23	A30914-002	Pump Mounting Bracket
7	02-2878-01	Sump End Cover	24	03-1417-05	Lockwasher
8	02-2868-01	Drain Trough	25	03-1406-05	Nut
9	no number	Cube Chute	26	03-1394-03	Pal Nut
10	02-2869-01	Sump	27	03-1408-34	Special Washer
11	A30918-001	Sump Inlet Tube	28	02-2642-01	Plate Mount
12	03-1531-01	Screw	29	A30296-020	Evaporator
13	12-2313-03	Solenoid Valve	30	13-0674-07	Drain Hose, 8"
14	16-0791-01	Half Union	31	13-0674-07	Pump Hose, 33"
15	16-0162-00	Stainer	32	03-0727-09	Thumbscrew
16	03-1394-01	Pal Nut	33	03-1417-03	Lockwasher
17	03-1645-01	Screw			

CM650E SERVICE PARTS

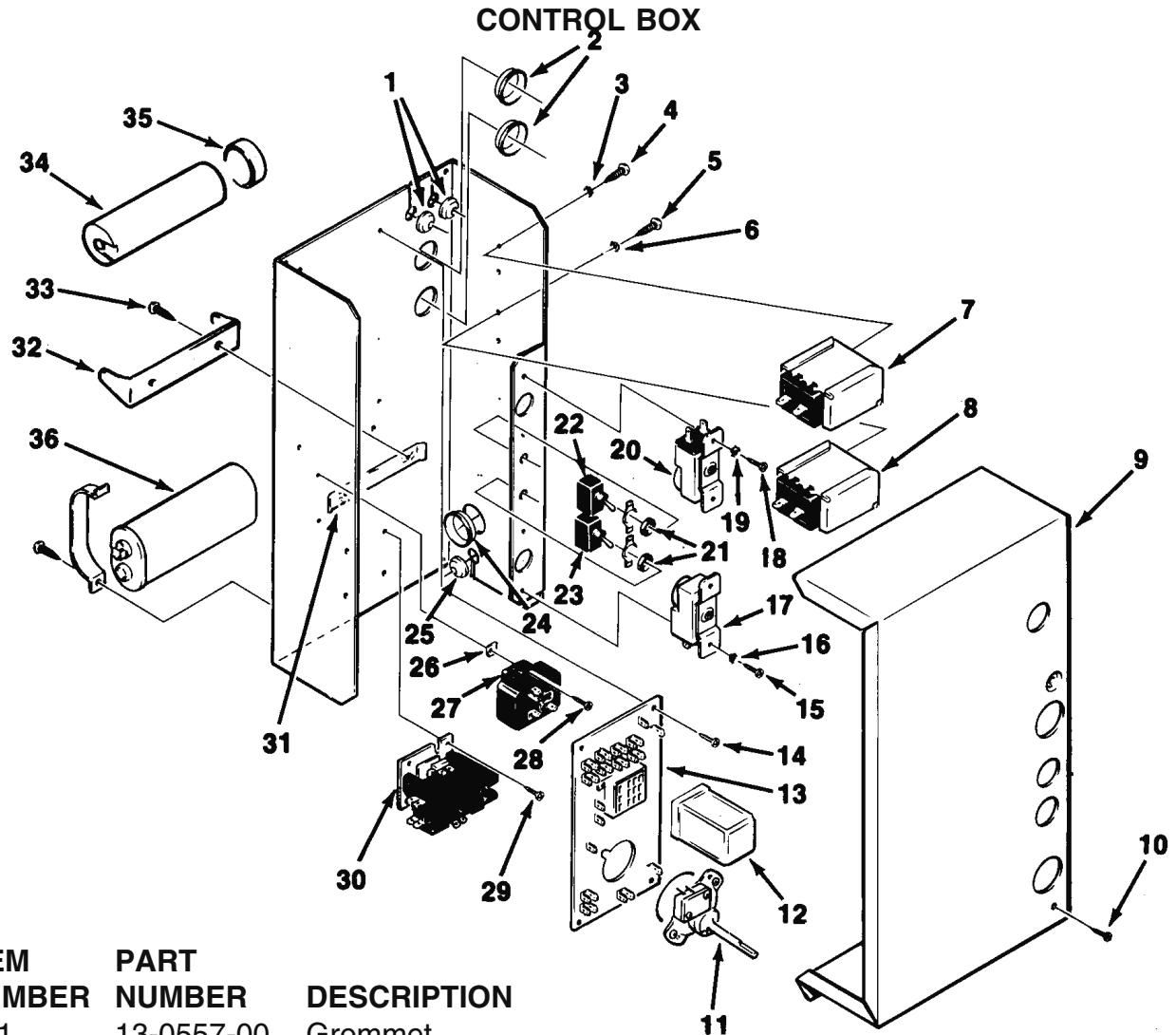

ITEM NUMBER	PART NUMBER	DESCRIPTION
1	13-0557-00	Grommet
2	12-1213-10	Snap Bushing
3	03-1417-18	Lockwasher
4	03-1403-02	Screw
5	03-1403-02	Screw
6	03-1417-18	Lockwasher
7	11-0426-22	Fan Control
8	11-0425-21	High Press. Safety -AC
	11-0410-22	High Press. Safety -WC
9	A32168-001	Control Box Cover
10	03-1531-01	Screw
11	12-2317-22	Timer & Switch
12	12-1879-03	Relay, 230 V
13	12-1912-01	Circuit Board
14	03-1403-02	Screw
15	03-1403-05	Screw
16	03-1417-03	Lockwasher
17	11-0427-22	Bin Thermostat
18	03-1403-05	Screw
19	03-1417-03	Lockwasher
20	11-0428-21	Cube Size Control

ITEM NUMBER	PART NUMBER	DESCRIPTION
21	03-1417-16	Lockwasher
22	12-0426-01	Switch
23	12-0426-01	Switch
24	12-1213-17	Snap Bushing
25	13-0557-00	Grommet
26	03-1423-01	Speed Nut
27	18-1903-46	Potential Relay
28	03-1403-02	Screw
29	03-1403-15	Screw
30	12-2469-02	Contactor, -32 (1 phase)
	12-0739-02	Contactor, -3 (3 phase)
31	no number	Twin Speed Nut
32	18-2200-39	Start Capacitor Bracket
33	03-1403-15	Screw
34	18-1901-48	Start Capacitor
35	18-2200-38	Start Capacitor Cap.
36	18-1902-45	Run Capacitor

CM650E WIRING DIAGRAMS

Schematic Diagram for CM650E-32E (208-230/60/1) Air or Water Cooled.

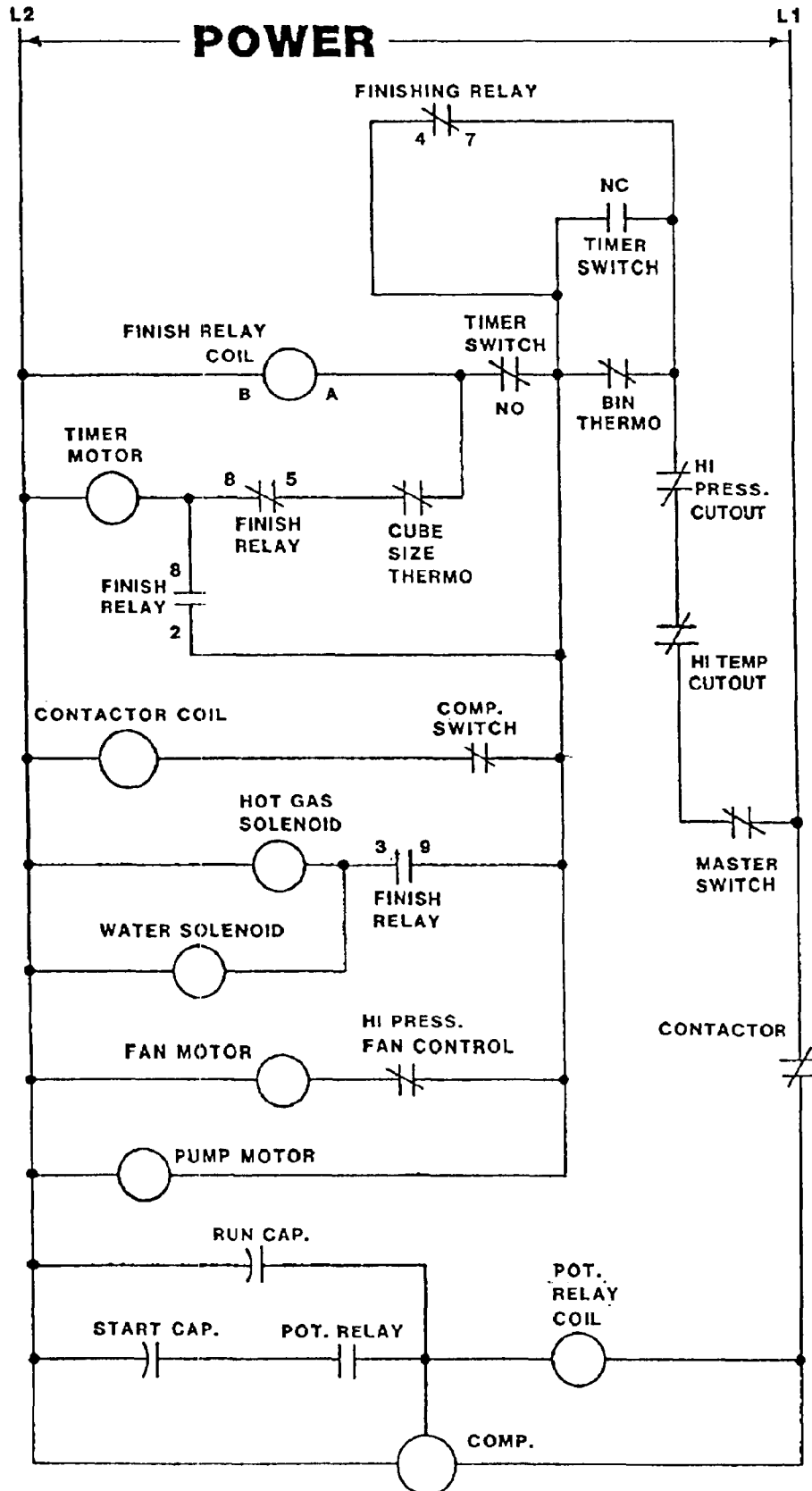

CM650E WIRING DIAGRAMS

Component Layout Diagram for CM650E-3E (208-230/60/3) Air and Water Cooled.

A32192-003

Caution: More Than One Disconnect Means May Be Required To Disconnect All Power From This Unit.

USE COPPER CONDUCTORS ONLY.

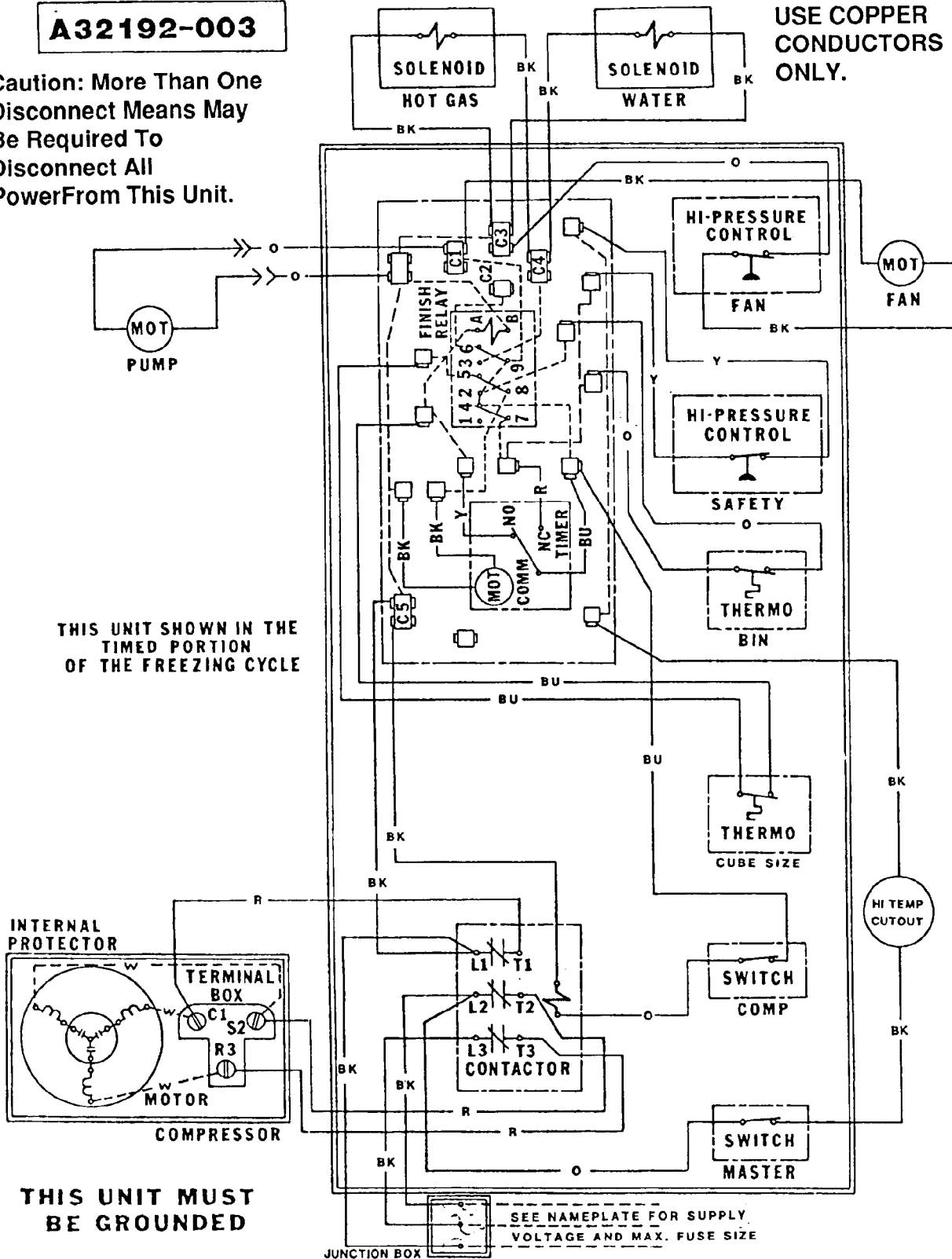

CM650E WIRING DIAGRAMS

Schematic Diagram for CM650E-3E, (208-230/60/3) Air or Water Cooled.

