

## CME256 or CME506 or CME656 or CME806 Service Parts

This parts list contains service part information for 8 basic models, plus 4 different electrical configurations. **The complete model number will be needed to identify the correct part.**

Model Series Changes (code at the end of the model number)

- C series - changes to the front & side panels
- D series - changes to the top panel and to the compressor starting components
- E series - new side panels and 2 TXVs with check valves for the CME506
- F series - new water cooled condensers

Electrical Codes are located at the end of the model number (voltage/hertz/phase):

- -1 is 115/60/1
- -32 is 208-230/60/1
- -3 is 208-230/60/3

Electrical Components Common to All Machines:

- Inlet water valve
- Water sensor
- Discharge line sensor
- Controller
- Ice sensor/bin controls
- Water level sensor

Unique Electrical Components

- Compressor and related starting components
- Contactor (single / three phase)
- Fan motor
- Water pump
- Transformer
- Hot gas valve

Other Unique parts include: side panels, electrical, refrigeration and some water system items.

- -6 is 250/50/1

### TABLE OF CONTENTS

Cabinet	PAGE 2
Interior Structure & Controls	PAGE 3
CME256 Air Cooled Refrigeration	PAGE 4
CME506 A - D Series Air Cooled Refrigeration	PAGE 5
CME506 E - F Series Air Cooled Refrigeration	PAGE 6
CME656 Air Cooled Refrigeration	PAGE 7
CME806 Air Cooled Refrigeration	PAGE 8
Water System Components	PAGE 9
CME256 Water Cooled Refrigeration	PAGE 10
CME506 A - D Series Water Cooled Refrigeration	PAGE 11
CME506 E - F Series Water Cooled Refrigeration	PAGE 12
CME656 Water Cooled Refrigeration	PAGE 13
CME806 Water Cooled Refrigeration	PAGE 14
Compressors and Electrical Components for CME256 and CME506	PAGE 15
Compressors and Electrical Components for CME656 and CME806	PAGE 16
HTB555 Ice Storage Bin	PAGE 17
D thru F Series Single Phase 60 Hz Schematic Diagram	PAGE 18
D thru F Series, 115 volt CME256 and CME506 Wiring Diagram	PAGE 19
D thru F Series CME656 or CME806 Single Phase Wiring Diagram	PAGE 20
D thru F Series CME656 Three Phase Wiring Diagram	PAGE 21
D thru F Series, 230 volt, 60 Hz. CME256 and CME506 Diagram	PAGE 22
D thru F Series CME506 50 Hz Air Cooled Diagram	PAGE 33
D thru F Series CME506 50 Hz Water Cooled Diagram	PAGE 34
D thru F Series CME656 or CME806 50 Hz Air Cooled Diagram	PAGE 35
D thru F Series CME656 or CME806 50 Hz Water Cooled Diagram	PAGE 36
D thru F Series, 50 Hz CME256 Diagram	PAGE 41

# CME256 or CME506 or CME656 or CME806 Service Parts

## Cabinet

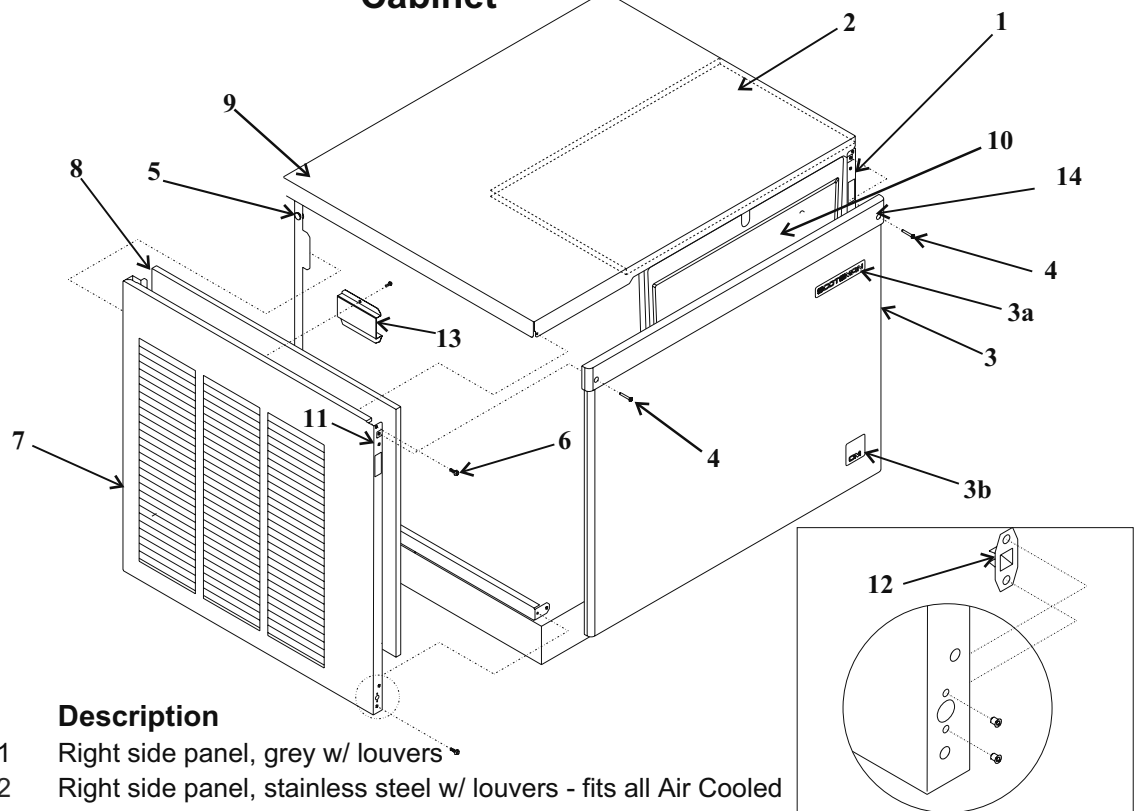

Item Number	Part Number	Description	
1	A35963-021	Right side panel, grey w/ louvers	
	A35963-022	Right side panel, stainless steel w/ louvers - fits all Air Cooled	
	A37071-021	Right side panel, painted w/out louvers (water cooled only)	
	A37071-022	A - D series right side panel, stainless steel without louvers (water cooled only)	
	A38126-021	E - F series right side panel, w/out louvers for water cooled only	
2	02-3659-01	Top insulation	
	02-3797-21	<b>C series Front panel kit, gray plastic</b> , includes trim strip & emblems	
3	03-1733-01	Strike (for C to E series panel, SS or plastic)	
	A37167-001	Front panel kit, SS, replaces gray plastic, includes item 10a (for A models)	
	A37488-021	<b>C to F series Front panel kit, stainless steel</b> , includes trim strip & emblems	
	A35964-002	Front panel kit, stainless steel (for A series)	
	15-0808-03	Emblem for ss panel (Scotsman); 03-0271-00 is the speed nut for emblem	
3a	15-0808-03	Emblem for ss panel (Scotsman); 03-0271-00 is the speed nut for emblem	
3b	15-0792-02	Emblem for C to F series front panel, (CM <sup>3</sup> )	
4	03-1735-01	Screw for trim strip (for C to F series)	
	03-1404-12	Sheet metal screw for plastic front panel (for A series)	
	03-1419-22	Sheet metal screw for ss front panel	
5	02-1875-03	Panel bumper/hole plug	
	03-1531-01	Sheet metal screw	
7	A35962-021	Left side panel, grey enamel with louvers	
	A35962-022	Left side panel, stainless steel with louvers	
	A37070-021	Left side panel, grey enamel without louvers (water cooled only)	
	A37070-022	A - D series left side panel, stainless steel without louvers (water cooled only)	
	A38127-021	E - F series left side panel, w/out louvers for water cooled only	
8	02-3485-01	Air filter, air cooled only	
	9	A35965-001	Top panel, grey enamel, order item 2 also
		A35965-002	Top panel, stainless steel, order item 2 also
		02-3822-21	Top panel, plastic, fits all, original to D series
10a	02-3663-01	Evaporator cover, use began Feb. 1997. Fits A and B series	
	02-3796-01	Insulation for above cover	
	02-3663-20	Evap cover w/ ins for C - F series	
11	03-1423-06	Speed nut for panel screws	
	12	03-1733-02	Catch
		13	A37326-001
	14	02-3794-01	Trim strip.
			03-1731-02 is the push nut for trim strip

**CME256 or CME506 or CME656 or CME806 Service Parts**

**Interior Structure & Controls**

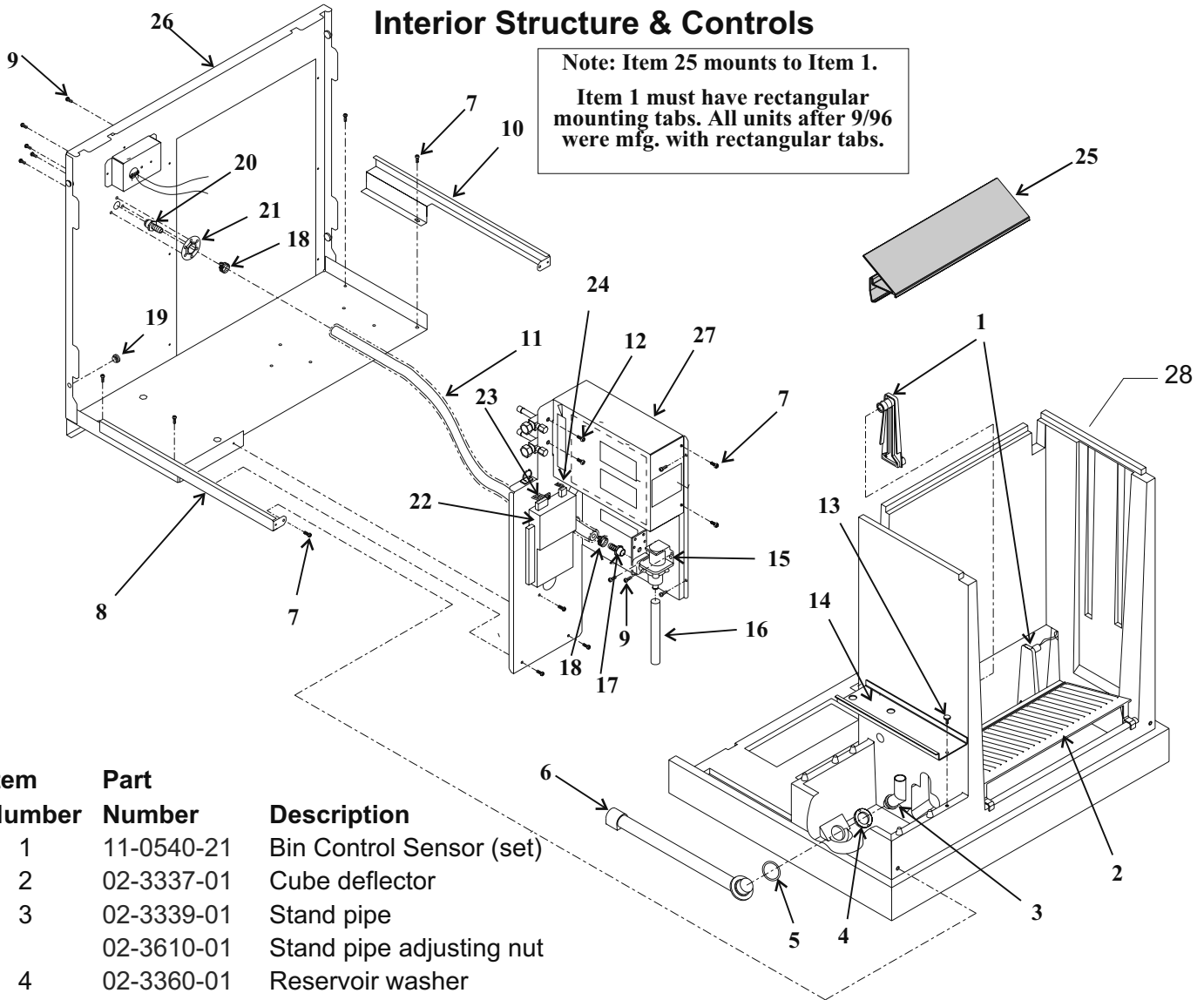

Item Number	Part Number	Description
1	11-0540-21	Bin Control Sensor (set)
2	02-3337-01	Cube deflector
3	02-3339-01	Stand pipe
	02-3610-01	Stand pipe adjusting nut
4	02-3360-01	Reservoir washer
5	13-0617-56	O-ring
6	02-3338-01	Drain tube & fittings
7	03-1404-18	Screw
8	A36298-001	Left side channel
9	03-1531-01	Screw
10	A36297-001	Right side channel
11	13-0906-01	Plastic inlet water hose,
21" req. order 2 units - not used after Sept. 1996		
12	03-1645-01	Screw
13	03-1691-01	Nylon screw
14	02-3340-01	Reservoir cover
15	12-2548-01	Inlet water valve
16	13-0674-02	Tubing, 9" req., order 1 unit
17	02-3443-01	Water fitting for hose
	16-1020-01	Water fitting for copper
18	02-0179-05	Clamp
19	13-0903-01	Bumper for side panels
	20	16-0997-01 Inlet water fitting for hose
		16-1019-01 Inlet water fitting for copper
	21	16-0701-07 Mounting flange
	22	12-2838-23 AutoIQ controller
	23	12-2644-21 Low voltage harness A - C series
		12-2782-21 Low volt harness, D + series 60 Hz
		12-2782-23 Low volt harness, D + series 50 Hz
	24	12-2618-01 Hi volt harness, w fan control A series
		12-2476-01 Hi volt harness for w/o fan control A-C
		12-2678-01 Hi volt harness for 50 Hz models A-C
		12-2784-21 Hi volt harness for D + series 60 Hz.
		12-2786-21 Hi volt harness for D + series 50 Hz.
	25	02-3657-01 Cascading shield, used on CME806, 656 and 506 after 2/97
	26	A36460-001 Back panel assy (ac)
		A36460-003 Back panel assy (wc)
	27	A35959-001 Hi voltage box cover
	28	A36457-001 Foamed base

**CME256 Air Cooled Refrigeration**

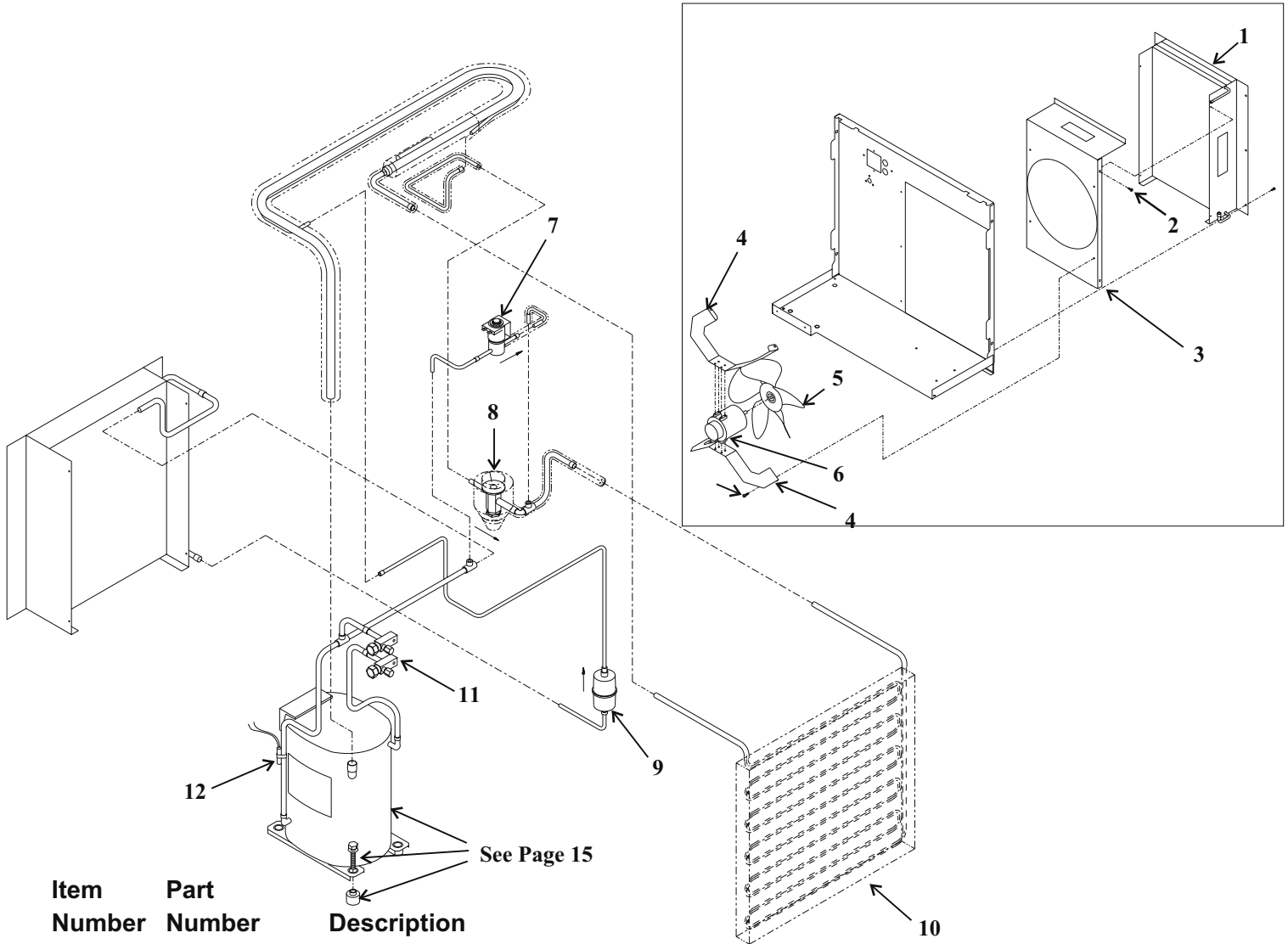

**Item Number**    **Part Number**    **Description**

1	18-8745-01	Condenser		
2	03-1531-01	Screw		
3	A36031-001	Shroud		
4	A36668-001	Motor bracket		
5	18-8503-01	Fan blade		
6	<b>18-5505-01</b>	<b>Fan motor for 115 volt, 60 Hz</b>		
	<b>18-5505-12</b>	<b>Fan motor for 230 volt, 50 Hz</b>		
	<b>18-5505-11</b>	<b>Fan motor for 230 volt, 60 Hz</b>		
7	12-2471-01	Hot gas valve w/coil		
	12-2719-23	Hot gas valve coil only		
8	16-1009-22	TXV		
	02-2920-01	Insulation for TXV		
9	02-3319-01	Dryer		
10	A36734-020	Evaporator		
11	16-0832-21	Access valve	12	02-3410-21
11a	16-0832-03	Port cap		03-1711-01
11b	16-0832-02	Stem cap		16-1063-02
				Hot gas valve strainer (not shown)

For models with a fan control switch:  
The part number of the fan control pressure switch is: 11-0508-21

CME256 or **CME506** or CME656 or CME806 Service Parts

**CME506 A - D** Series Air Cooled Refrigeration

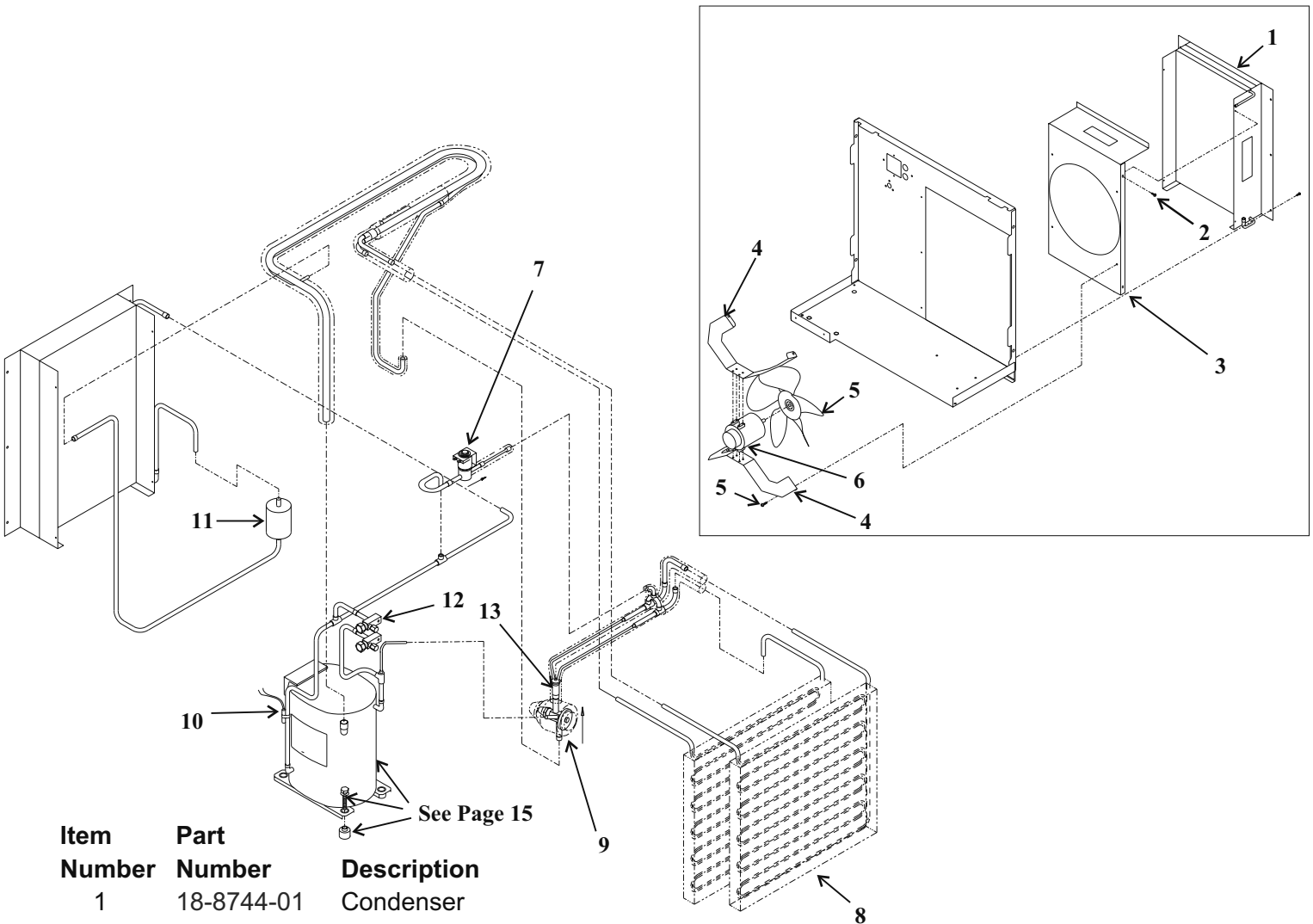

For models with a fan control switch:  
The part number of the fan control pressure switch is: 11-0508-21

Item Number	Part Number	Description	
1	18-8744-01	Condenser	
2	03-1531-01	Screw	
3	A35967-001	Shroud	
4	A36668-001	Motor bracket	
5	18-8503-01	Fan blade	
6	<b>18-5505-01</b>	<b>Fan motor for 115 volt, 60 Hz.</b>	
	<b>18-5505-12</b>	<b>Fan motor for 230 volt, 50 Hz.</b>	
	<b>18-5505-11</b>	<b>Fan motor for 230 volt, 60 Hz</b>	
7	12-2471-22	Hot gas valve w/coil	
	12-2719-23	Hot gas valve coil only	
8	A36734-020	Evaporator	
9	16-1017-21	TXV (was 16-0867-21, they are interchangeable)	
	02-2920-01	Insulation for TXV	
10	02-3410-21	Temp. sensor, includes water temp. & clip	
11	02-3319-02	Dryer	
12	16-0832-21	Access valve	
12a	16-0832-03	Port cap	
12b	16-0832-02	Stem cap	
	13	16-0843-03	Distributor assembly
	14	16-1063-01	Hot gas valve strainer (not shown)

**CME506 E - F Series Air Cooled Refrigeration**

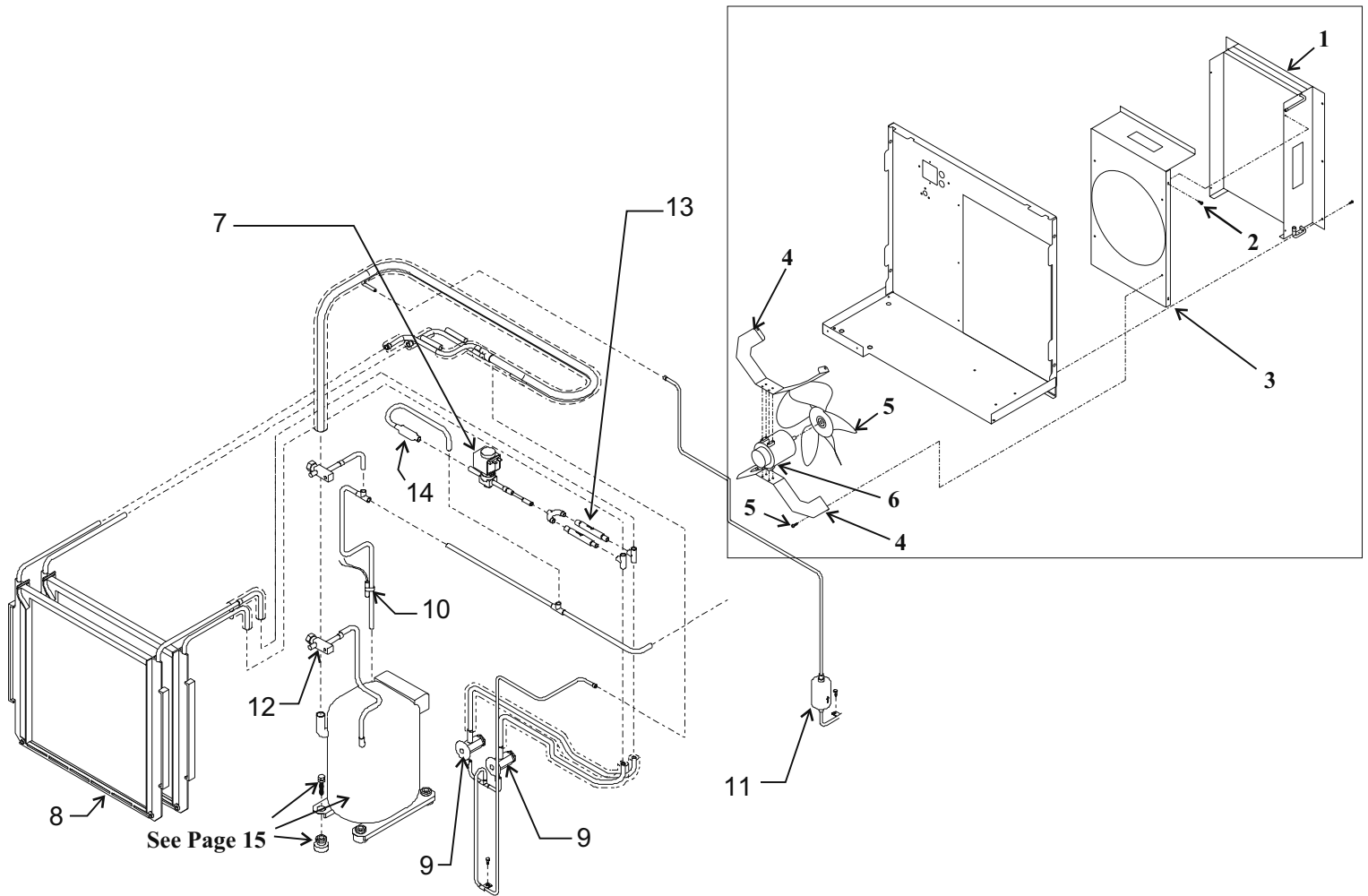

Item Number	Part Number	Description
1	18-8866-01	Condenser - E Series & up
2	03-1531-01	Screw
3	A35967-001	Shroud
4	A36668-001	Motor bracket
5	18-8503-01	Fan blade
6	<b>18-5505-01</b>	Fan motor for 115 volt, 60 Hz.
	<b>18-5505-12</b>	Fan motor for 230 volt, 50 Hz.
	<b>18-5505-11</b>	Fan motor for 230 volt, 60 Hz
7	12-2471-22	Hot gas valve w/coil
	12-2719-23	Hot gas valve coil only
8	A36734-020	Evaporator
9	16-1009-22	TXV - only for E series & up
	02-3792-01	Insulation for TXV
10	02-3410-21	Temp. sensor, includes water temp. sensor. & clip

Item Number	Part Number	Description
11	02-3319-01	Dryer
12	16-0832-21	Access valve
12a	16-0832-03	Port cap
12b	16-0832-02	Stem cap
13	16-1071-01	Check valve
14	16-1063-01	Hot gas valve strainer



**CME806 Air Cooled Refrigeration**

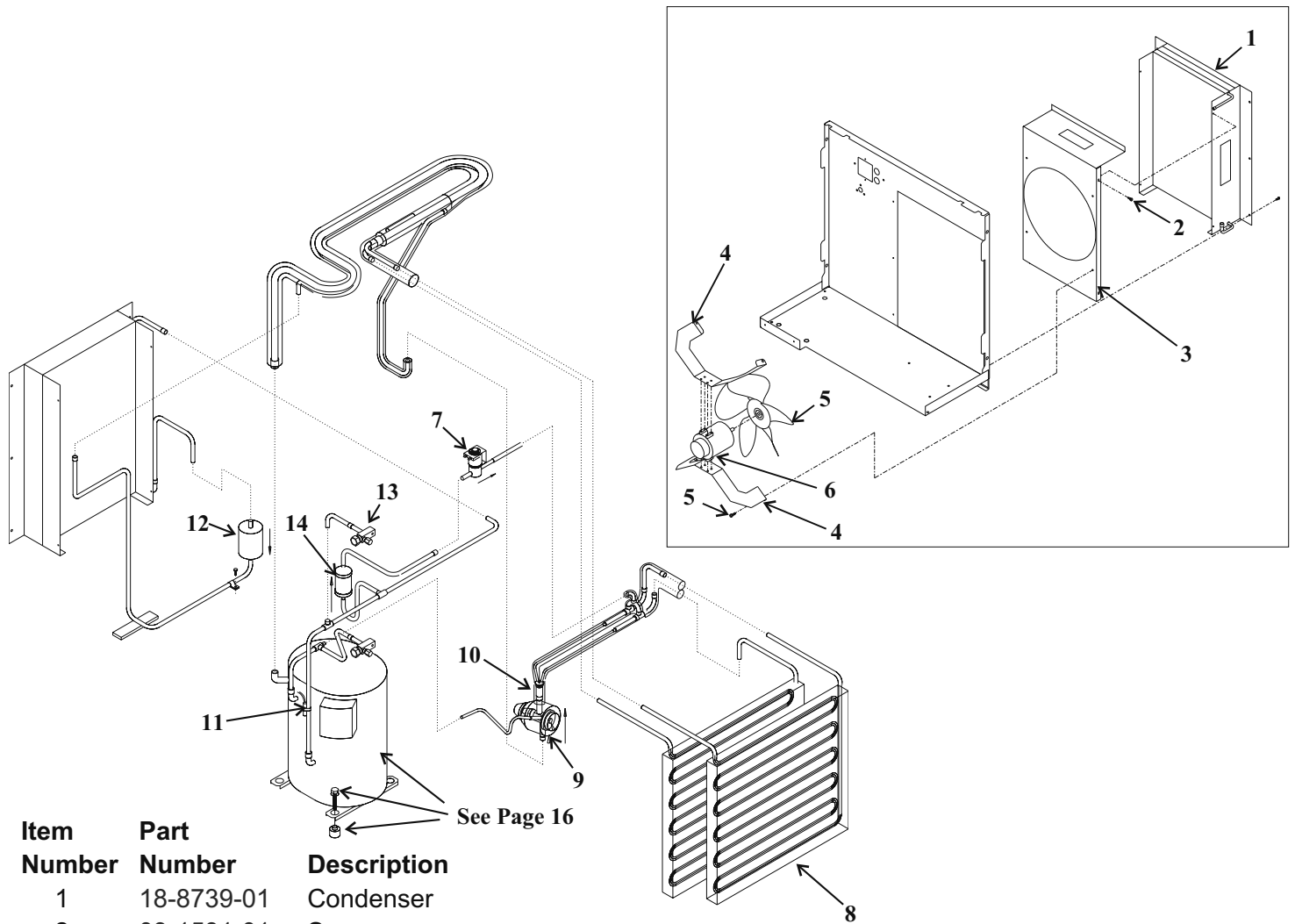

Item Number	Part Number	Description
1	18-8739-01	Condenser
2	03-1531-01	Screw
3	A35967-001	Shroud
4	A36668-001	Motor bracket
5	18-8503-01	Fan blade
6	<b>18-8829-01</b>	<b>Fan motor for 60 Hz.</b>
	<b>18-8829-02</b>	<b>Fan motor for 50 Hz.</b>
7	12-2471-24	Hot gas valve complete w/coil
	12-2719-23	Hot gas valve coil only
	12-2733-30	Hot gas valve repair kit (no body, no coil)
8	A36734-020	Evaporator
9	16-1065-21	TXV
	02-3396-01	Insulation for TXV
10	16-0843-02	Distributor and tubes
11	02-3410-21	Temperature sensor, includes water temp sensor & clip
	03-1711-01	Clip
12	02-3319-02	Dryer
13	16-0832-21	Access valve
13a	16-0832-03	Port cap
13b	16-0832-02	Stem cap
14	16-1063-01	Hot gas valve strainer



CME256 or CME506 or CME656 or CME806 Service Parts

Water System Components

Single Evaporator Models

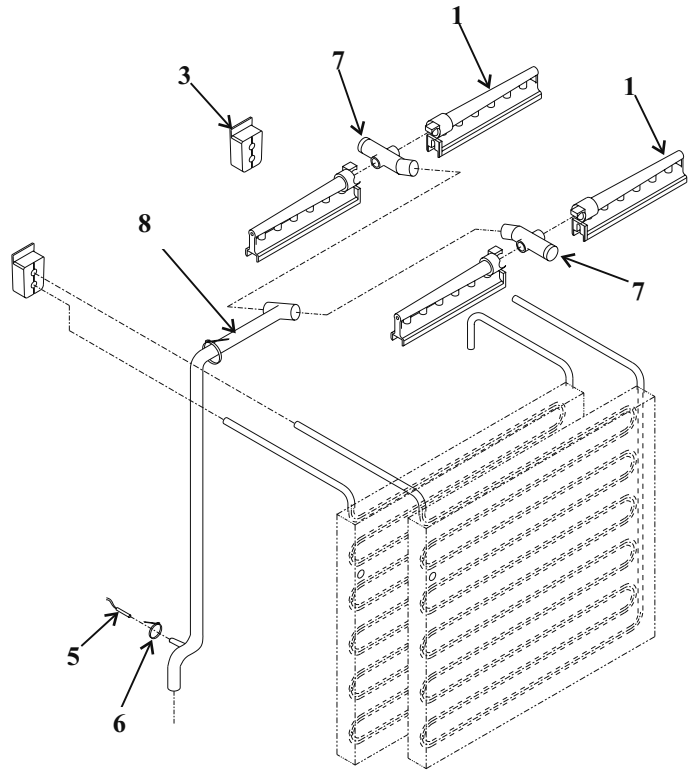
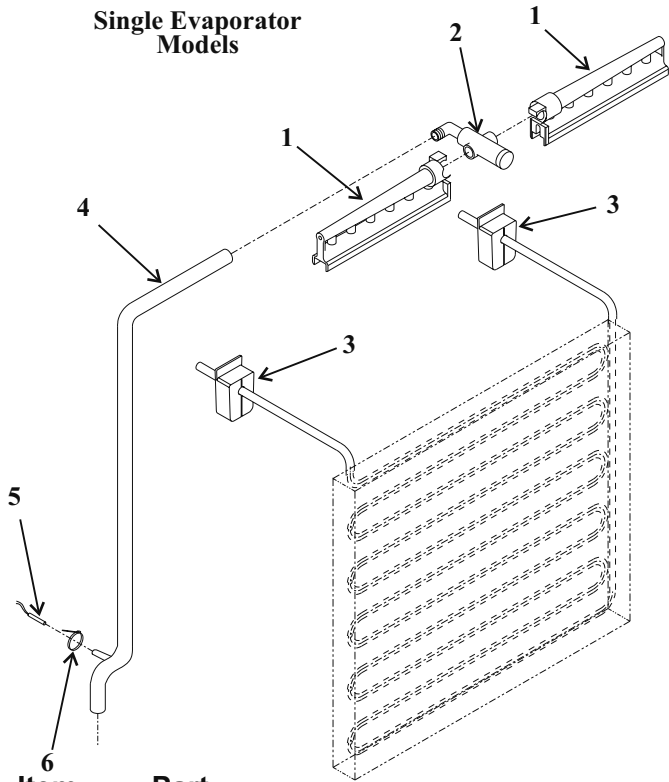

Two Evaporator Models

Item Number	Part Number	Description
1	02-2527-01	Water distributor
2	A30926-001	Distributor manifold
3	13-0898-02	Tubing grommet
4	02-3361-01	Water discharge tube for <b>single</b> evaporator models
5	02-3410-21	Water temperature sensor includes disch. temp. sensor
6	no number	Cable tie
7	02-3405-01	Inlet Tee
8	02-3336-01	Water distributor tube for <b>double</b> evaporator models
9	02-3383-01	Float stem, <b>1 evaporator model*</b>
	02-3383-02	Float stem, <b>2 evaporator model*</b>
10	11-0539-21	Float (water level) sensor
11	02-3388-04	Front pump bracket for 12-2586 type pump
12	02-3388-05	Rear pump bracket for 12-2586 type pump
13	12-2506-01	Harness
14	02-3341-01	Float
15	12-2586-21	<b>CME256-1 (115 volt) pump</b>
	12-2586-27	<b>CME506-1 (115 volt) pump</b>
	12-2586-26	<b>CME256-6 or -32 (208-230 volt),</b>
	12-2586-23	<b>CME506-6 or 32 (208-230 volt),</b>
		<b>CME656 or CME806 (208-230 volt) pump. 50 or 60 Hz.</b>

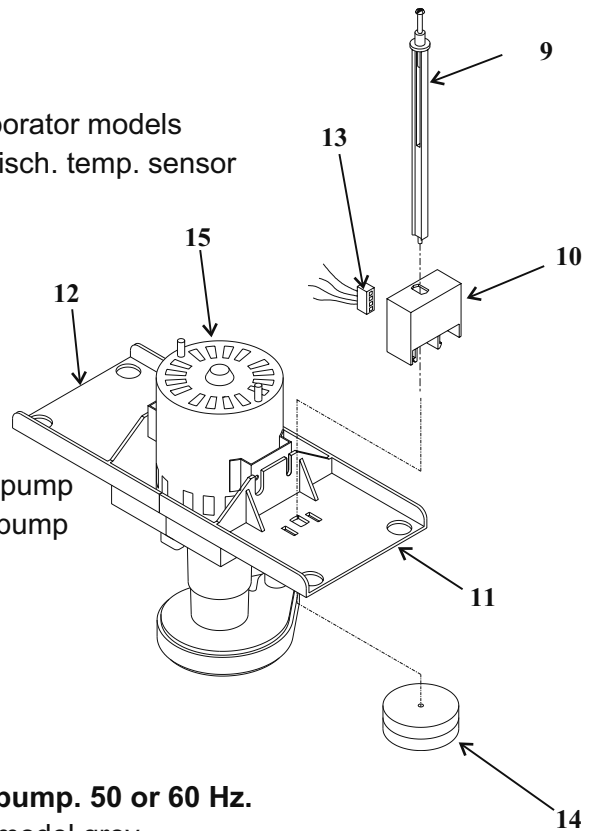

\* Not adjustable after 2/97. Then 1 evap model white, 2 evap. model grey.

**CME256 Water Cooled Refrigeration**

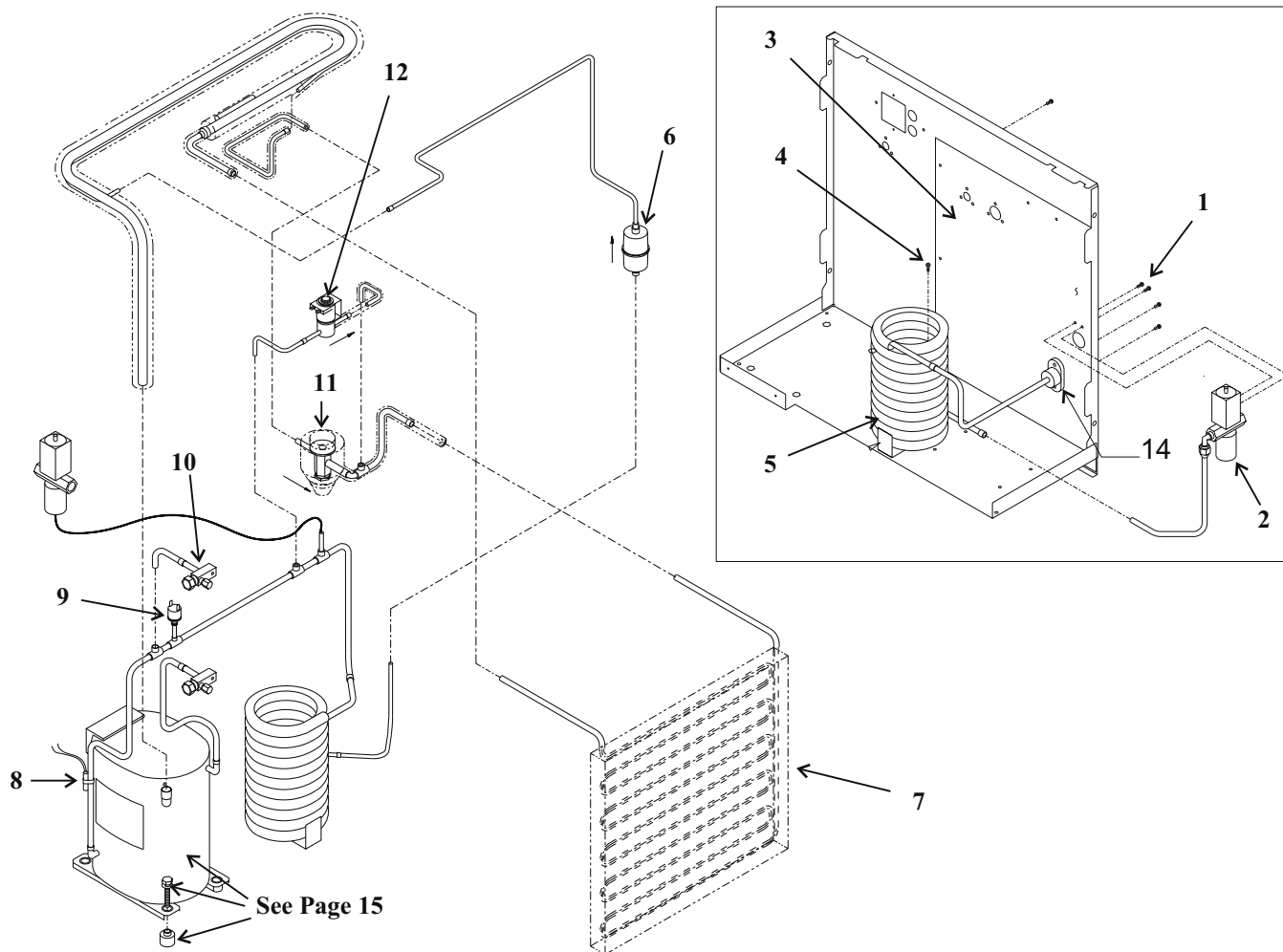

Item Number	Part Number	Description	Item Number	Part Number	Description
1	03-1403-15	Screw	12	12-2471-01	Hot gas valve w/coil
2	11-0478-01	Water regulating valve	12	12-2719-23	Hot gas valve coil only
3	A36440-001	Back cover	13	16-1063-02	Hot gas valve strainer (not shown)
4	03-1645-01	Screw	14	A31828-001	Fitting
5	18-3306-25	Condenser, A thru E series			
	18-8871-21	Condenser, F series			
6	02-3319-01	Dryer			
7	A36734-020	Evaporator			
8	02-3410-21	Hi temperature sensor, includes water temp sensor & clip			
	03-1711-01	Clip for sensor			
9	11-0501-21	Hi pressure cut out			
10	16-0832-21	Access valve			
10a	16-0832-03	Port cap			
10b	16-0832-02	Stem cap			
11	16-1009-22	TXV 1/4 ton			
	02-2920-01	Insulation for TXV			



**CME506 E - F Series Water Cooled Refrigeration**

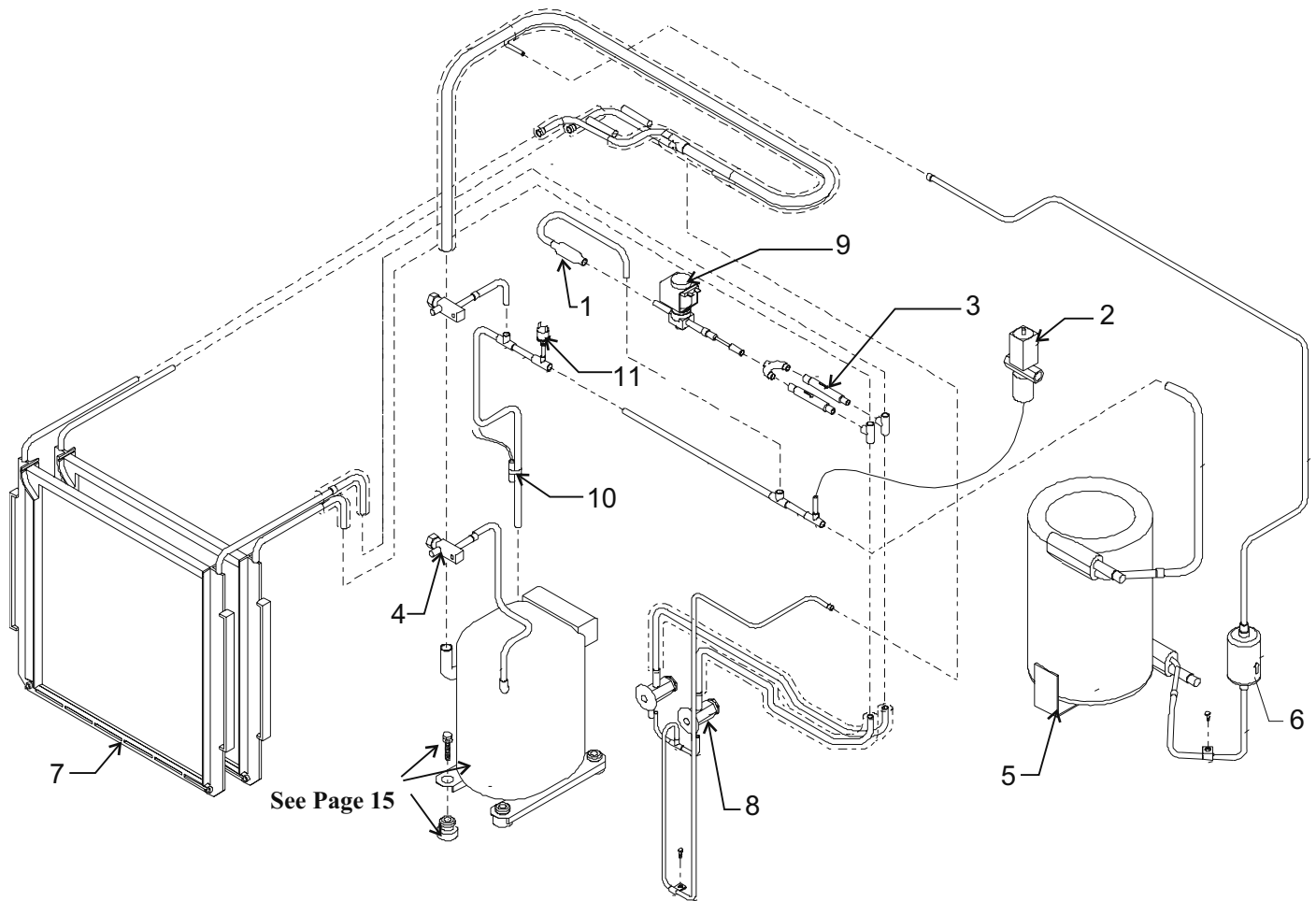

See Page 15

Item Number	Part Number	Description
1	16-1063-01	Hot gas valve strainer
2	11-0478-21	Water regulating valve
3	16-1071-01	Check valve
4	16-0832-21	Access valve
	16-0832-03	Port cap
5	18-3306-25	Condenser, E series
	18-8871-21	Condenser, F series
	03-1645-01	Screw to mount condenser (not shown)
6	02-3319-02	Dryer
7	A36734-020	Evaporator
8	16-1009-22	TXV for E Series & up
	02-2920-01	Insulation for TXV
9	12-2471-22	Hot gas valve w/coil
	12-2719-23	Hot gas valve coil only
10	02-3410-21	Hi temperature sensor, includes water temperature sensor
	03-1711-01	Clip for sensor
11	11-0501-21	Hi pressure cut out
12	A31828-001	Fitting

**CME656 Water Cooled Refrigeration**

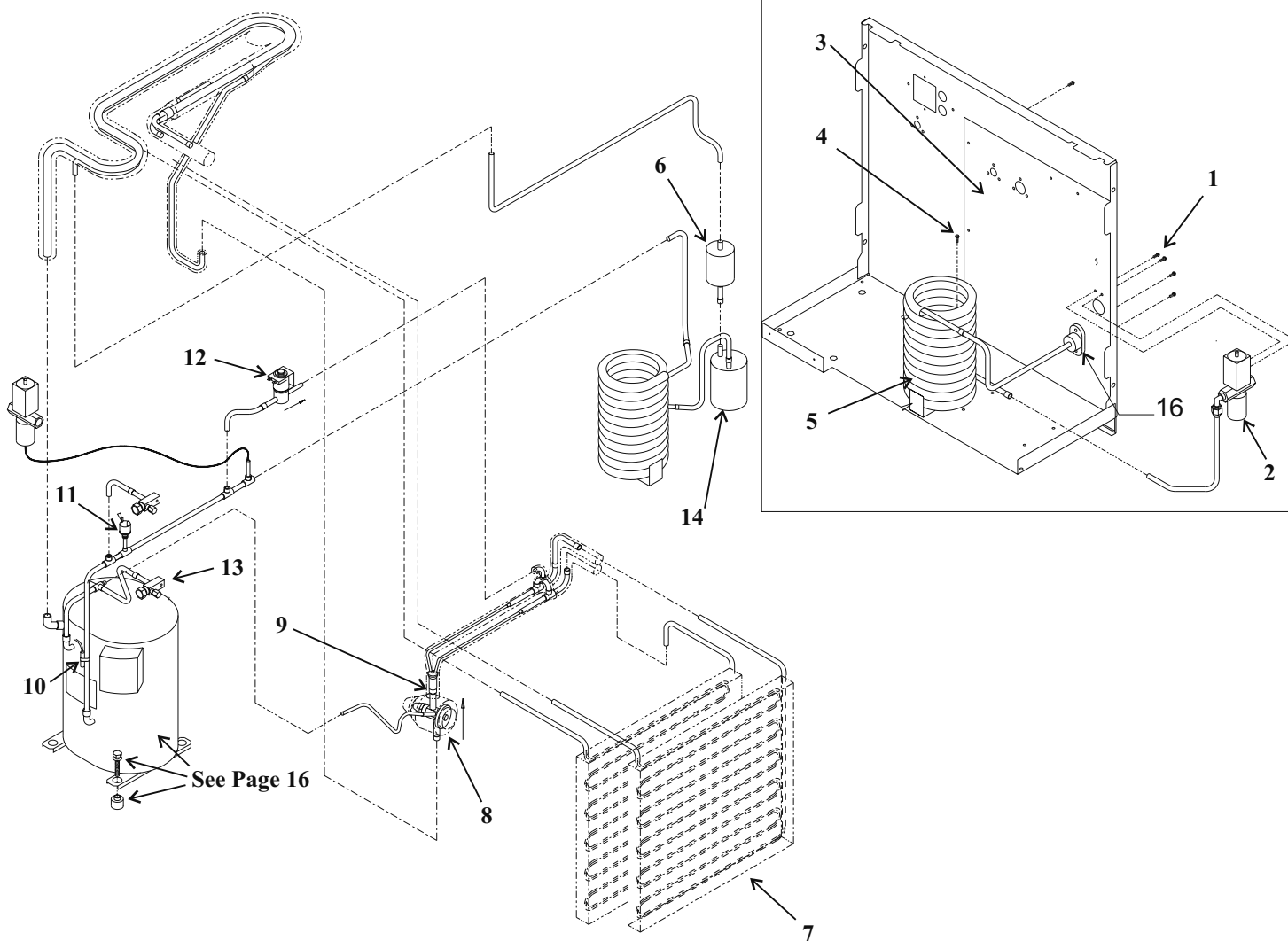

Item Number	Part Number	Description	Item Number	Part Number	Description
1	03-1403-15	Screw	11	11-0501-21	Hi pressure cut out
2	11-0478-01	Water regulating valve	12	12-2471-22	Hot gas valve w/coil
3	A36440-001	Back cover		12-2719-23	Hot gas valve coil only
4	03-1645-01	Screw	13	16-0832-21	Access valve
5	18-6900-25	Condenser, A - E series	13a	16-0832-03	Port cap
	18-8874-21	Condenser, F series	14	16-0874-01	Receiver
6	02-3319-02	Dryer	15	16-1063-01	Hot gas valve strainer, not shown
7	A36734-020	Evaporator	16	A31828-001	Fitting
8	16-1065-21	TXV 1/2 ton (was 16-0867-22 or 16-1018-21 all interchangeable)			
-	02-2920-01	Insulation for TXV			
9	16-0843-02	Distributor and tubes			
10	02-3410-21	Hi temperature sensor, includes water temperature sensor			
	03-1711-01	Clip for sensor mounting			

**CME806 Water Cooled Refrigeration**

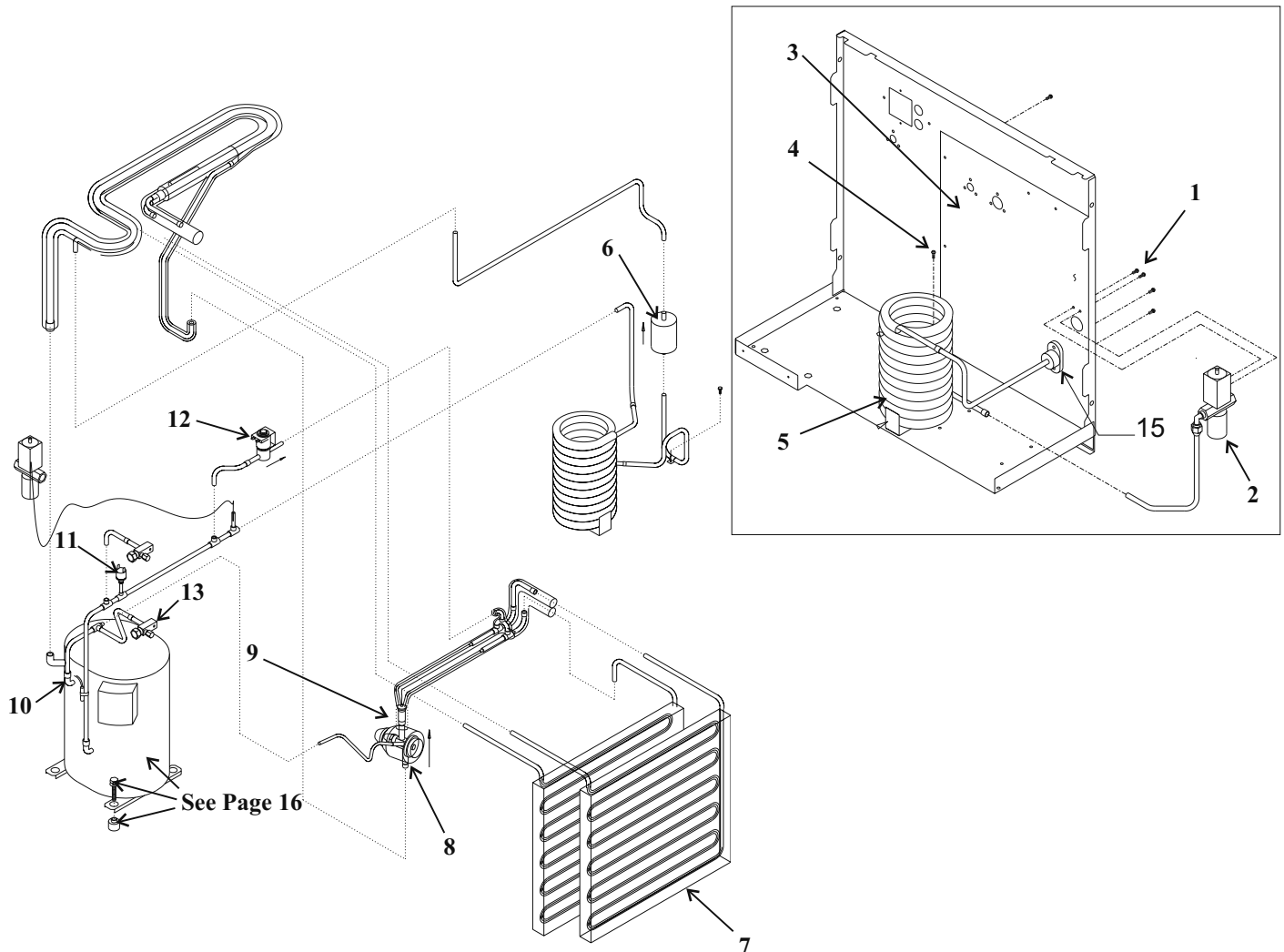

Item Number	Part Number	Description	Item Number	Part Number	Description
1	03-1403-15	Screw	12	12-2471-24	Hot gas valve complete w/coil
2	11-0478-01	Water regulating valve		12-2719-23	Hot gas valve coil only
3	A36440-001	Back cover		12-2733-30	Hot gas valve repair kit, no coil, no body
4	03-1645-01	Screw	13	16-0832-21	Access valve
5	18-6900-21	Condenser, A - E series	13a	16-0832-03	Port cap
	18-8874-21	Condenser, F series	14	16-1063-01	Hot gas valve strainer, not shown
6	02-3319-02	Dryer	15	A31828-001	Fitting
7	A36734-020	Evaporator			
8	16-1065-21	TXV 1/2 ton			
8a	02-3396-01	Insulation for TXV			
9	16-0843-02	Distributor and tubes			
10	02-3410-21	Hi temperature sensor, includes water temperature sensor			
	03-1711-01	Clip for sensor mounting			
11	11-0501-21	Hi pressure cut out			

**CME256 or CME506 or CME656 or CME806 Service Parts**

**Compressors and Electrical Components for CME256 and CME506**

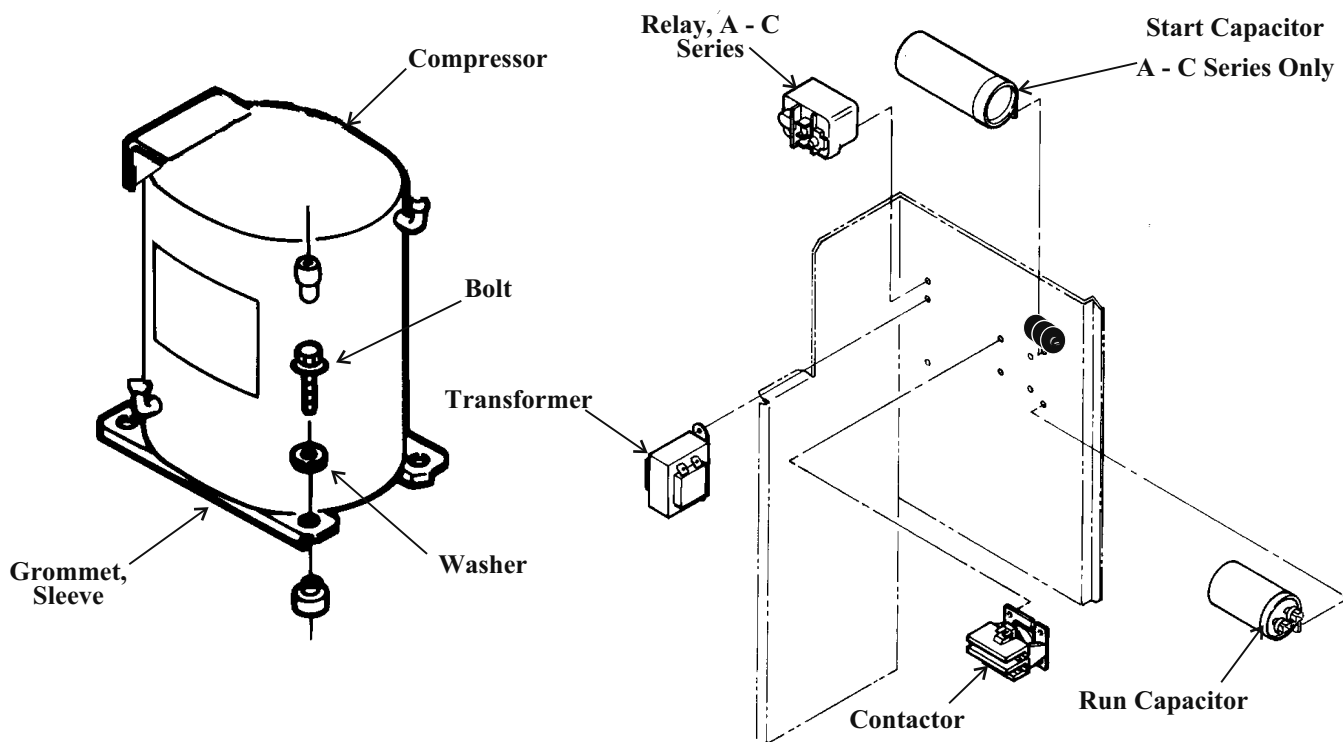

Model	CME256			CME506		
	115/60	208-230/60	230/50	115/60	208-230/60	230/50
Voltage/Hz	115/60	208-230/60	230/50	115/60	208-230/60	230/50
Phase	Single	Single	Single	Single	Single	Single
Compressor	18-8720-21*	18-8838-23*	18-8838-22	18-8721-21*	18-8839-23*	18-8721-22
<b>PTCR - D thru F series only</b>	18-8835-01	18-8835-01	18-8835-01	18-8835-01	18-8835-01	18-8835-01
Start Relay**	18-1903-44	not used	not used	18-1903-50	not used	18-1903-29
Start Capacitor**	18-1901-49	not used	18-2200-35	18-1901-03	not used	18-1901-43
Run Capacitor	18-1902-52	18-1902-17	not used	18-1902-45	18-1902-45	18-1902-30
Overload	18-5700-50	18-8838-50	18-5700-55	18-8711-50	18-8839-50	18-8721-50
Mounting Bolt	03-1405-20	03-1405-20	03-1405-20	03-1405-20	03-1405-20	03-1405-20
Sleeve	18-2200-27	18-2200-27	18-2200-27	18-2200-27	18-2200-27	18-2200-27
Washer	03-1407-07	03-1407-07	03-1407-07	03-1407-07	03-1407-07	03-1407-07
Grommet	18-2200-28	18-2200-28	18-2200-28	18-2200-28	18-2200-28	18-2200-28
Contactora	12-2469-01	12-2469-01	12-2469-01	12-2469-01	12-2469-01	12-2469-01
Transformer	A37231-001	A37217-001	12-2639-02	A37231-001	A37217-001	A37217-001

\* Includes starting components. All compressors include a drier. \*\* D thru F series uses PTCR

-6B, C, D, E, F series	Transformer	Hi Voltage Harness	Fuse	Fuse Block	Relay	Relay Bracket
CME256 or CME506	12-2639-02	12-2678-21	12-2686-01	12-2687-01	12-2679-01	12-2680-01

## CME256 or CME506 or CME656 or CME806 Service Parts

### Compressors and Electrical Components for CME656 and CME806

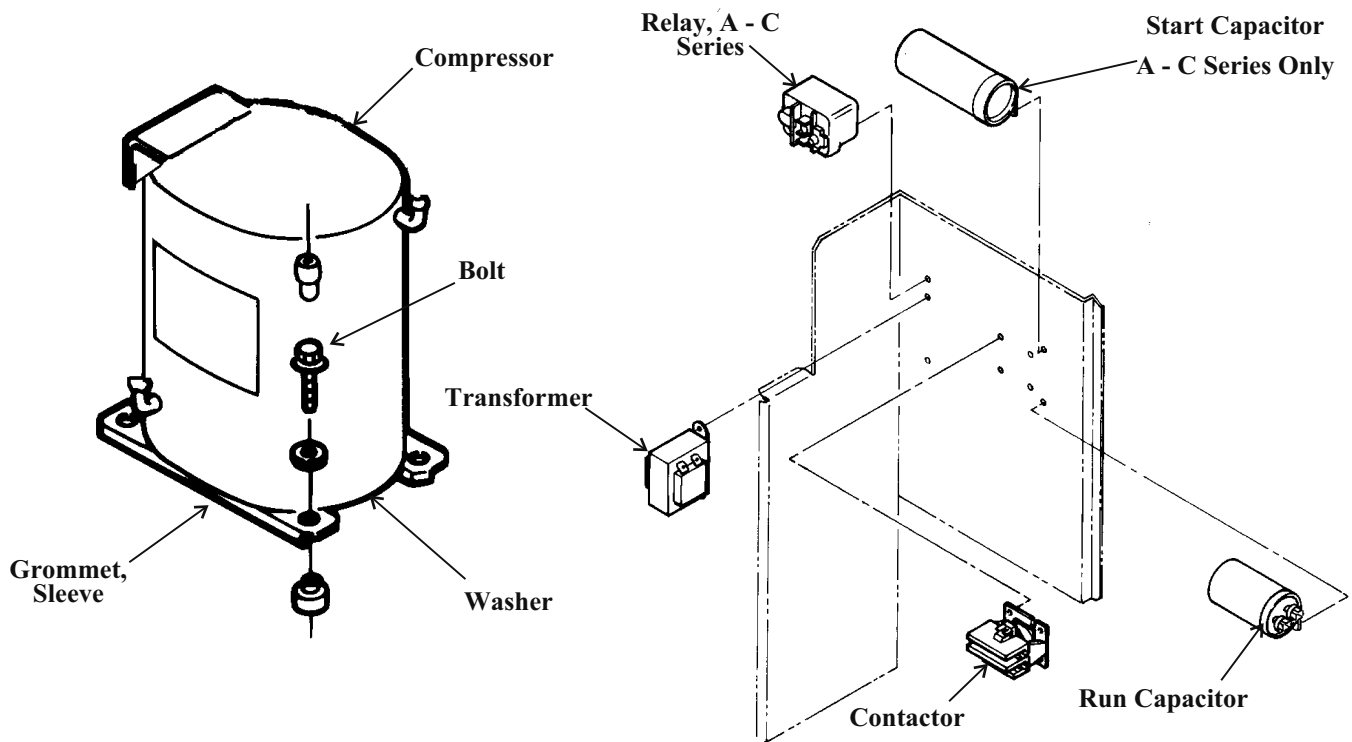

Model	CME656			CME806		
	208-230/60	208-230/60	230/50	208-230/60	208-230/60	230/50
Voltage/Hz	208-230/60	208-230/60	230/50	208-230/60	208-230/60	230/50
Phase	Single	Three	Single	Single	Three	Single
Compressor	18-8813-23*	18-8813-25	18-8813-27	18-8749-22*	18-8749-24	18-8749-27
PTCR - <b>D thru F series only</b>	18-8835-01	not used	18-8835-01	18-8835-01	not used	18-8835-01
Start Relay**	18-1903-33	not used	18-1903-29	18-1903-46	not used	18-1903-33
Start Capacitor**	18-1901-15	not used	18-1901-52	18-1901-48	not used	18-1901-48
Run Capacitor	18-1902-53	not used	18-1902-53	18-1902-55	not used	18-1902-55
Overload	internal	internal	internal	internal	internal	internal
Mounting Bolt	03-1405-20	03-1405-20	03-1405-20	03-1405-20	03-1405-20	03-1405-20
Sleeve	18-2200-27	18-2200-27	18-2200-27	18-2200-27	18-2200-27	18-2200-27
Washer	03-1407-07	03-1407-07	03-1407-07	03-1407-07	03-1407-07	03-1407-07
Grommet	18-2200-28	18-2200-28	18-2200-28	18-2200-28	18-2200-28	18-2200-28
Contactor	12-2469-01	12-2533-01	12-2469-01	12-2469-01	12-2533-01	12-2469-01
Transformer	A37217-001	A37217-001	A37217-001	A37217-001	A37217-001	A37217-001

\* Includes starting components. All compressors include a drier. \*\* **D thru F series uses PTCR**

-6B, C, D, E, F series	Transformer	Hi Voltage Harness	Fuse	Fuse Block	Relay	Relay Bracket
CME656 or CME806	12-2639-02	12-2678-21	12-2686-01	12-2687-01	12-2679-01	12-2680-01



CME256 or CME506 or CME656 or CME806 Service Parts

HTB555 Ice Storage Bin

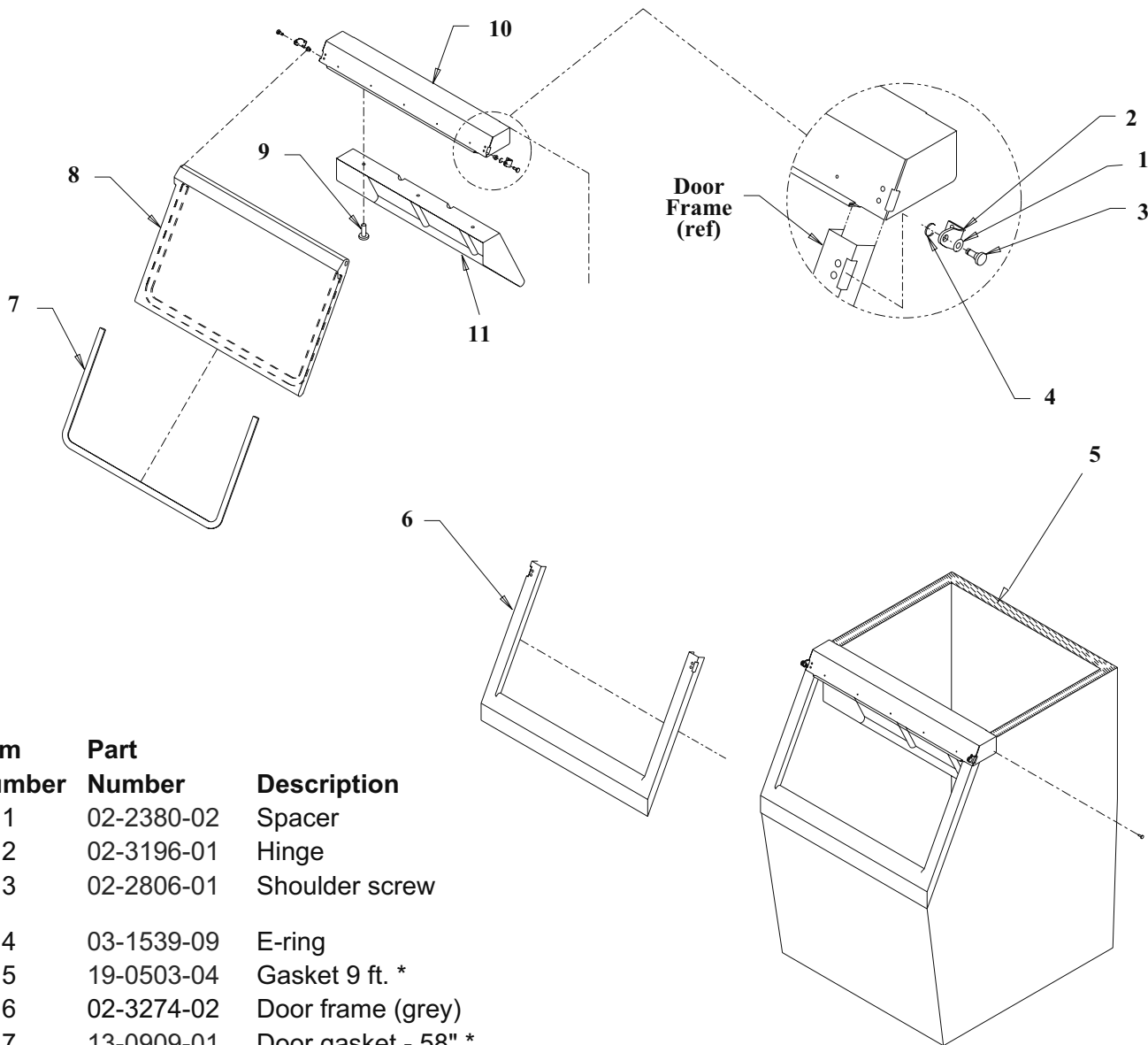

Item Number	Part Number	Description
1	02-2380-02	Spacer
2	02-3196-01	Hinge
3	02-2806-01	Shoulder screw
4	03-1539-09	E-ring
5	19-0503-04	Gasket 9 ft. *
6	02-3274-02	Door frame (grey)
7	13-0909-01	Door gasket - 58" *
8	A36481-022	Door, grey, includes #7.
9	03-0727-11	Thumb screw
10	A35637-001	Canopy
11	A35640-001	Baffle
12	02-2809-02	Drain top
13	13-0617-09	O-ring
14	02-3108-01	Drain bottom

Not shown

03-1404-07	Screw for drain bottom
05-0586-01	Drain elbow
02-0540-00	Scoop
KLP2E	Enamel leg kit

\* Order gasket by the foot.

Optional: A35477-001 Scoop holder, not shown

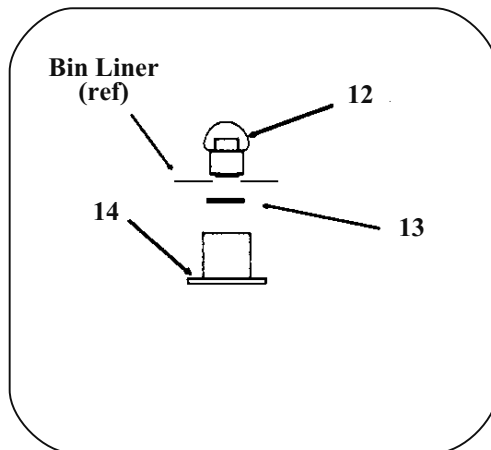

CME256 or CME506 or CME656 or CME806 Service Parts

D thru F Series Single Phase 60 Hz Schematic Diagram

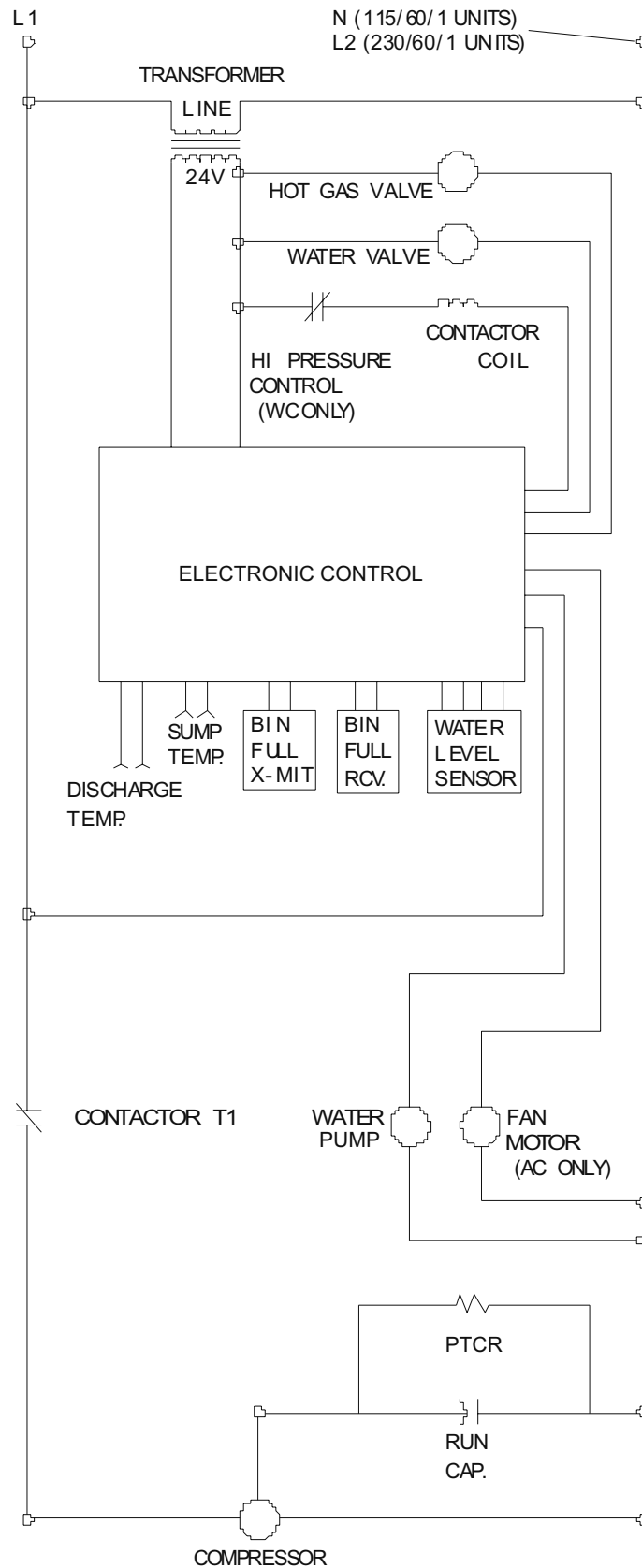

**CME256 or CME506 or CME656 or CME806 Service Parts**

**D thru F Series, 115 volt CME256 and CME506 Wiring Diagram**

17-2747-01

**USE COPPER CONDUCTORS ONLY**

**⚠ DASHED LINES INDICATE FIELD WIRING WHICH MUST BE INSTALLED IN ACCORDANCE WITH THE NATIONAL ELECTRICAL CODE AND ALL STATE AND LOCAL CODES.**

**CAUTION: PTCR WILL BE HOT. COMPRESSOR MAY NOT START IF PTCR IS NOT ALLOWED TO COOL.**

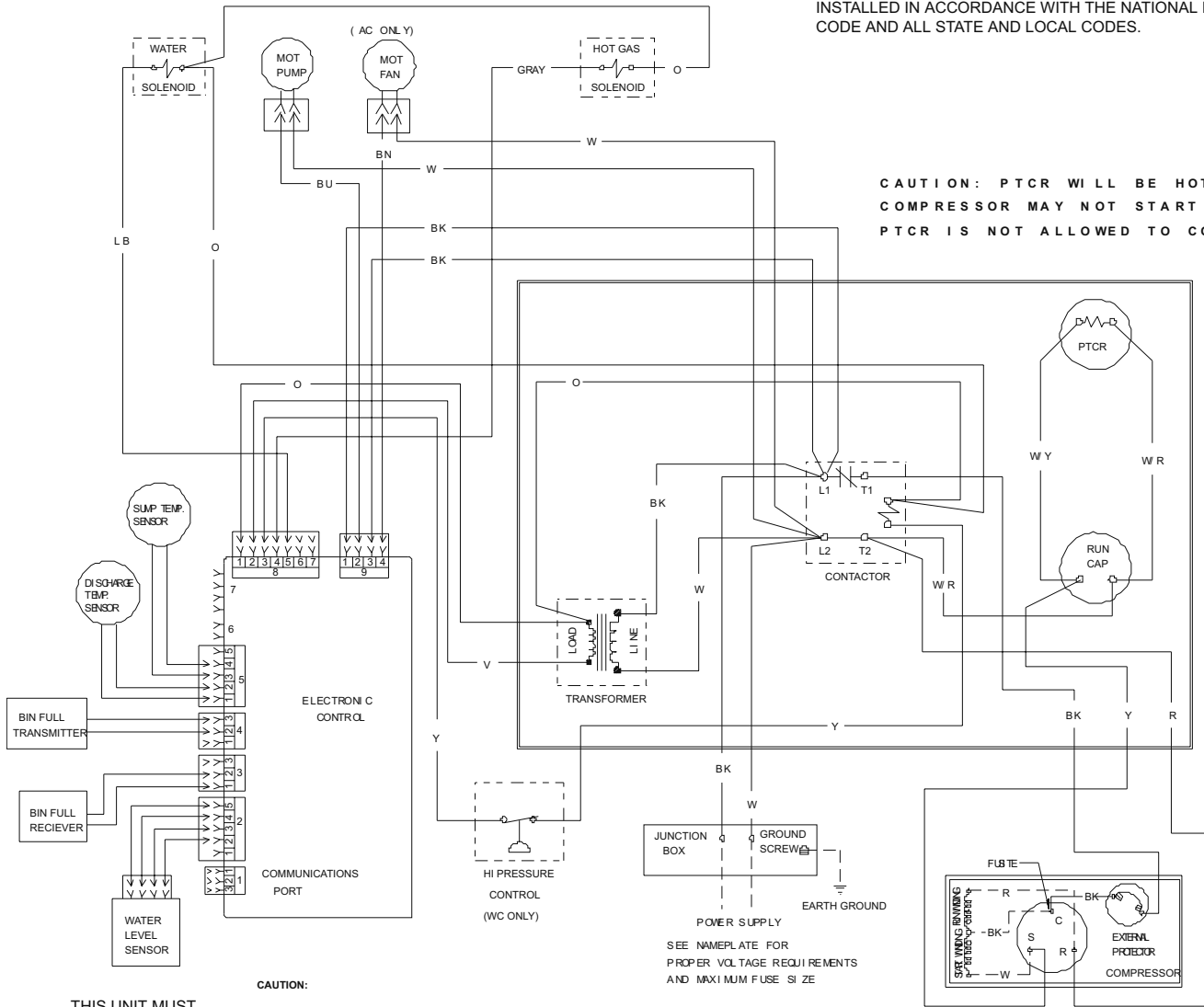

**THIS UNIT MUST BE GROUNDED.**

**CAUTION: MORE THAN ONE DISCONNECT MEANS MAY BE REQUIRED TO DISCONNECT ALL POWER TO THIS UNIT.**

SEE NAMEPLATE FOR PROPER VOLTAGE REQUIREMENTS AND MAXIMUM FUSE SIZE

# CME256 or CME506 or CME656 or CME806 Service Parts

## D thru F Series CME656 or CME806 Single Phase Wiring Diagram

17-2751-01

**USE COPPER CONDUCTORS ONLY**

**1** DASHED LINES INDICATE FIELD WIRING WHICH MUST BE INSTALLED IN ACCORDANCE WITH THE NATIONAL ELECTRICAL CODE AND ALL STATE AND LOCAL CODES.

**CAUTION: PTCR WILL BE HOT. COMPRESSOR MAY NOT START IF PTCR IS NOT ALLOWED TO COOL.**

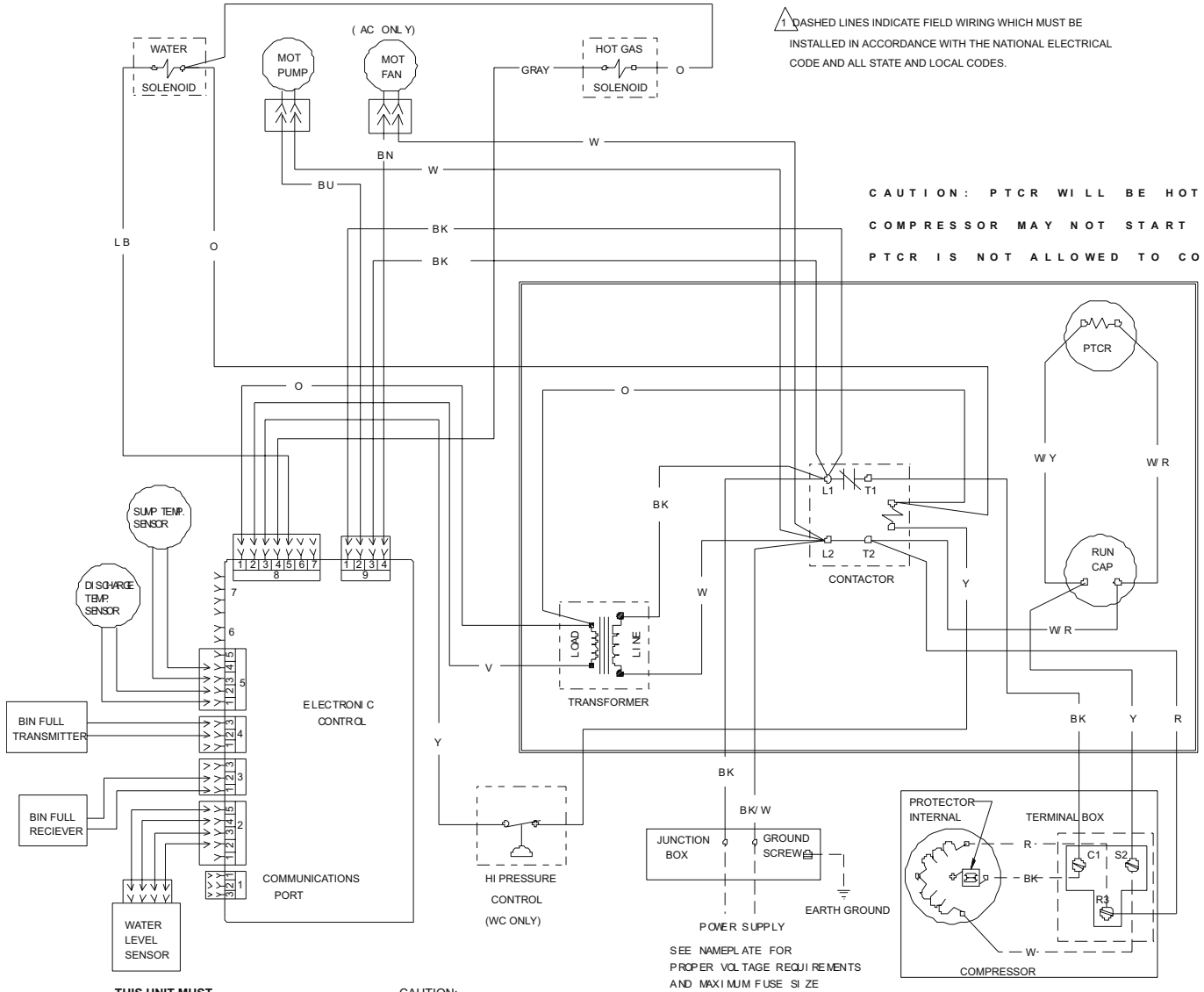

**THIS UNIT MUST BE GROUNDED.**

**CAUTION:**  
 MORE THAN ONE DISCONNECT MEANS MAY BE REQUIRED TO DISCONNECT ALL POWER TO THIS UNIT.

SEE NAMEPLATE FOR PROPER VOLTAGE REQUIREMENTS AND MAXIMUM FUSE SIZE

# CME256 or CME506 or CME656 or CME806 Service Parts

## D thru F Series CME656 Three Phase Wiring Diagram

17-2757-01

**USE COPPER CONDUCTORS ONLY**

**1** DASHED LINES INDICATE FIELD WIRING WHICH MUST BE INSTALLED IN ACCORDANCE WITH THE NATIONAL ELECTRICAL CODE AND ALL STATE AND LOCAL CODES.

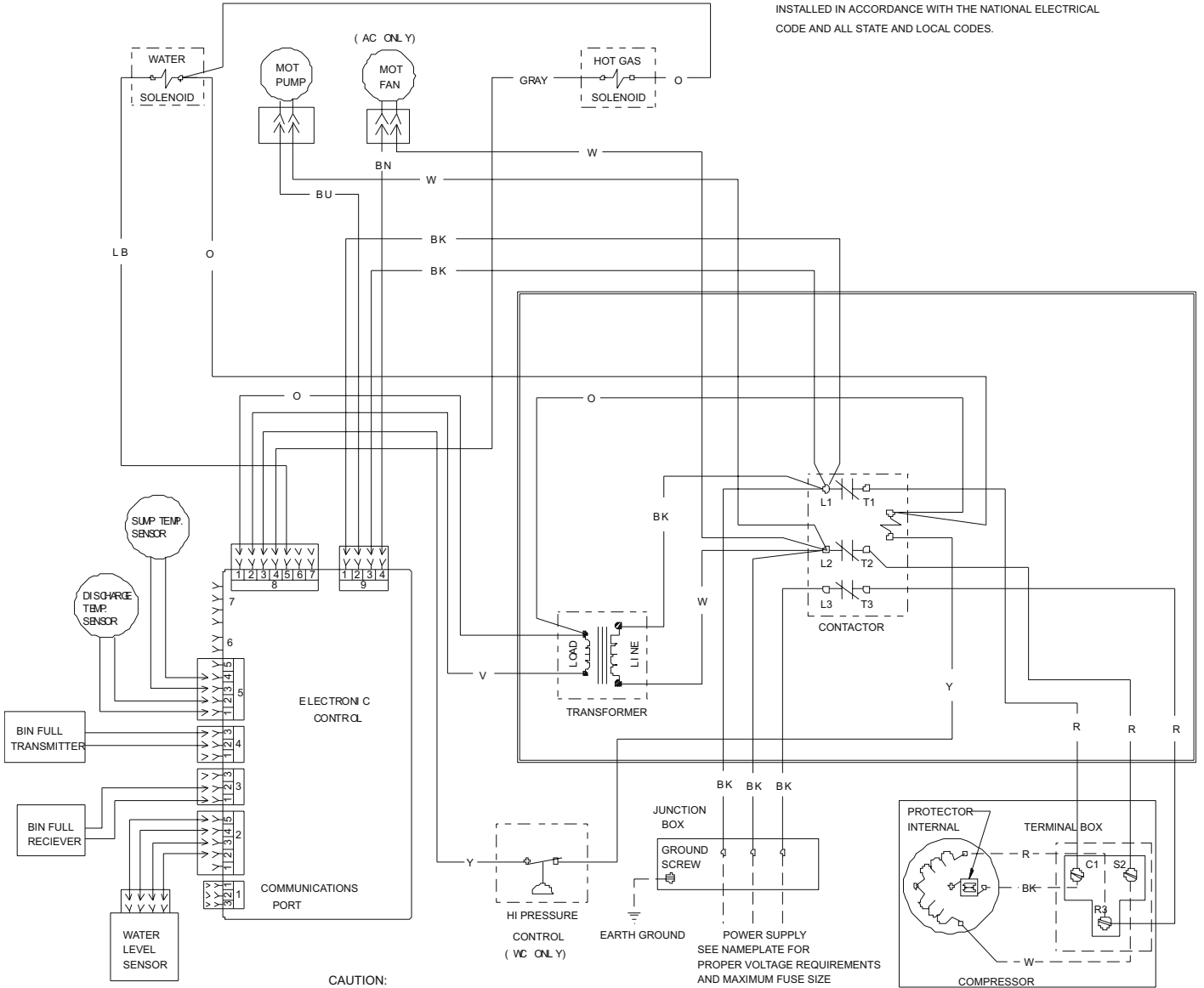

**THIS UNIT MUST BE GROUNDED.**

**CAUTION:**  
 MORE THAN ONE DISCONNECT MEANS MAY BE REQUIRED TO DISCONNECT ALL POWER TO THIS UNIT.

D thru F Series, 230 volt, 60 Hz. CME256 and CME506 Diagram

△ WIRING LINES INDICATE FIELD WIRING WHICH MUST BE INSTALLED IN ACCORDANCE WITH THE NATIONAL ELECTRICAL CODE AND ALL STATE AND LOCAL CODES.

USE COPPER CONDUCTORS ONLY

17-2863-01

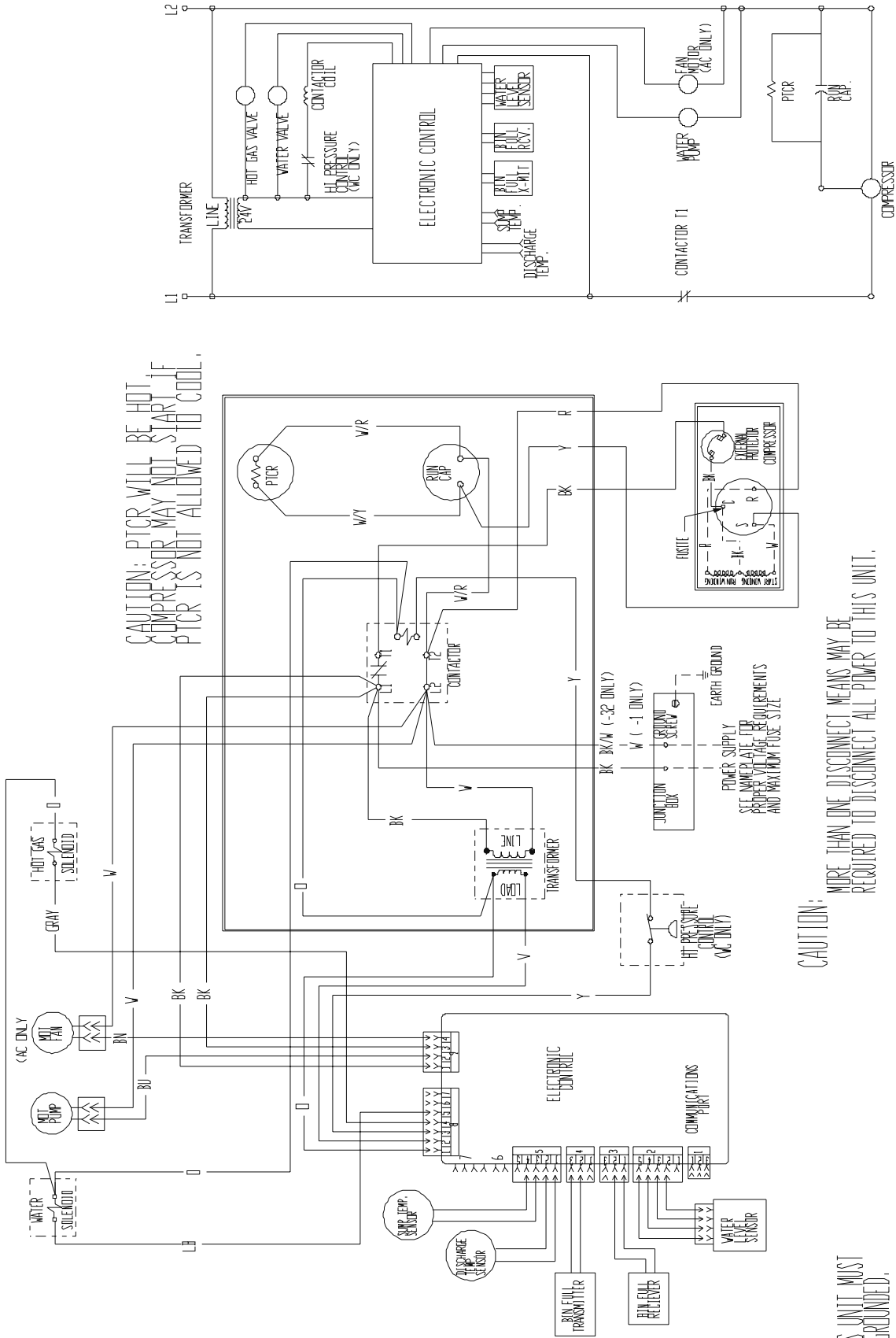

CAUTION: PTCR WILL BE HOT. COMPRESSOR MAY NOT START IF PTCR IS NOT ALLOWED TO COOL.

CAUTION: MORE THAN ONE DISCONNECT MEANS MAY BE REQUIRED TO DISCONNECT ALL POWER TO THIS UNIT.

THIS UNIT MUST BE GROUNDED.

**CME256 or CME506 or CME656 or CME806 Service Parts**

**A - C Series Single Phase Air Cooled Schematic Diagram**

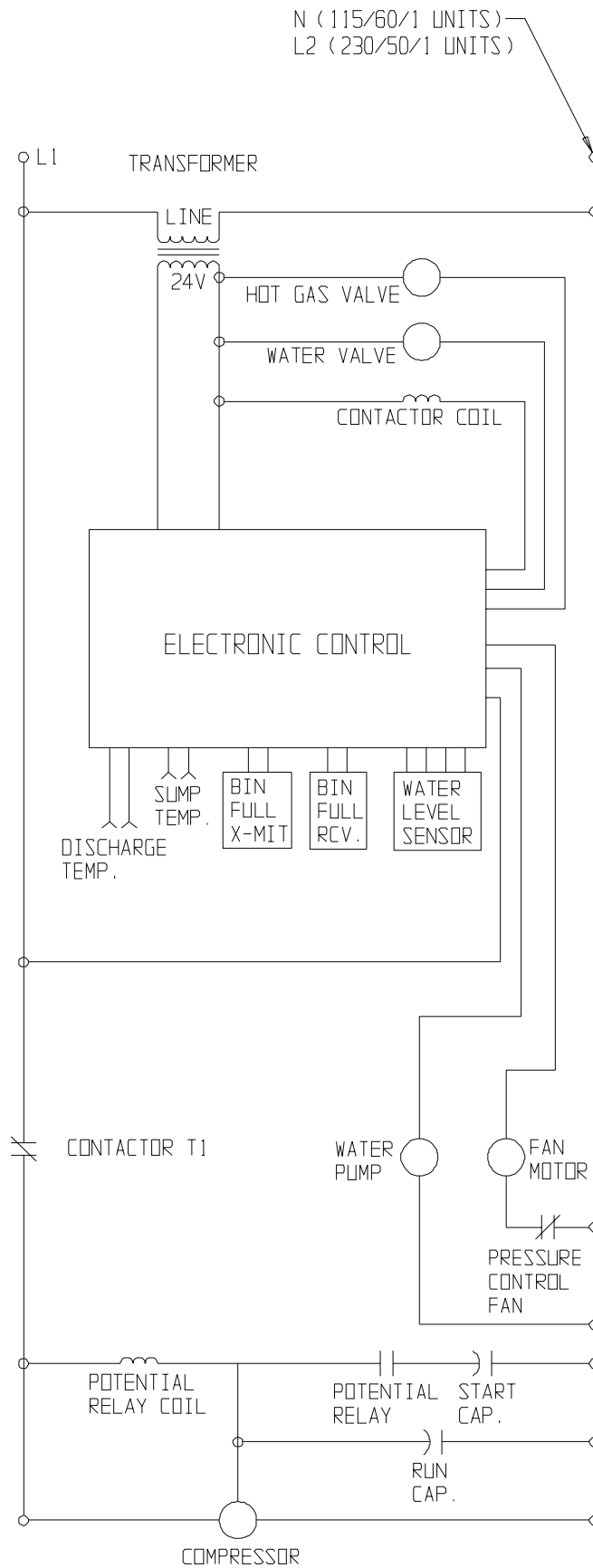

# CME256 or CME506 or CME656 or CME806 Service Parts

## A - C Series CME256 and CME506 Air Cooled Wiring Diagram

A36991-001

USE COPPER CONDUCTORS ONLY

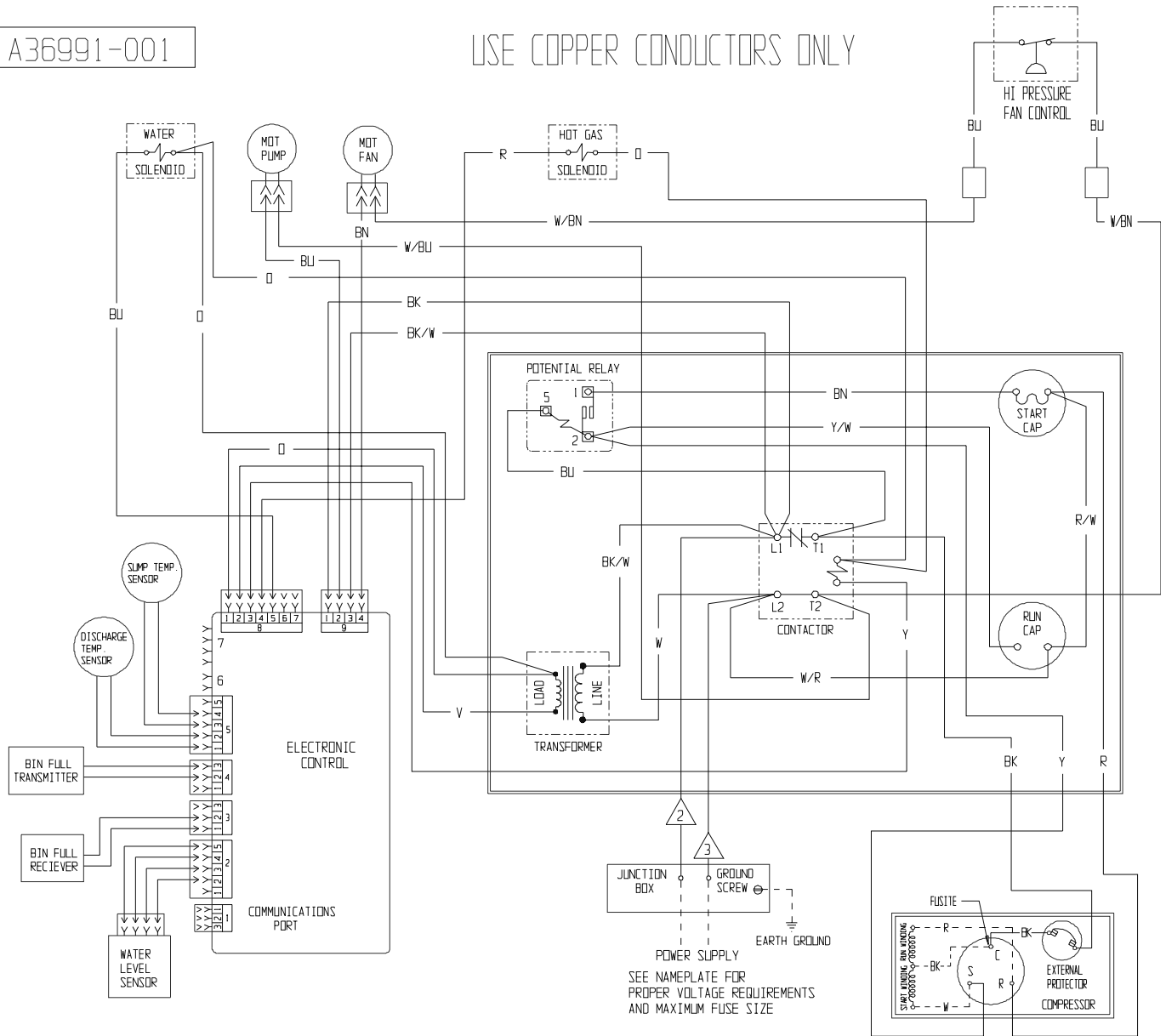

THIS UNIT MUST BE GROUNDED.

### CAUTION:

MORE THAN ONE DISCONNECT MEANS MAY BE REQUIRED TO DISCONNECT ALL POWER TO THIS UNIT.

- ⚠ DASHED LINES INDICATE FIELD WIRING WHICH MUST BE INSTALLED IN ACCORDANCE WITH THE NATIONAL ELECTRICAL CODE AND ALL STATE AND LOCAL CODES.
- ⚠ WIRE COLOR FOR 115/60/1 UNITS: BLACK  
WIRE COLOR FOR 230/50/1 UNITS : BROWN
- ⚠ WIRE COLOR FOR 115/60/1 UNITS: WHITE  
WIRE COLOR FOR 230/50/1 UNITS : BROWN



### A - C Series Water Cooled Single Phase Schematic Diagram

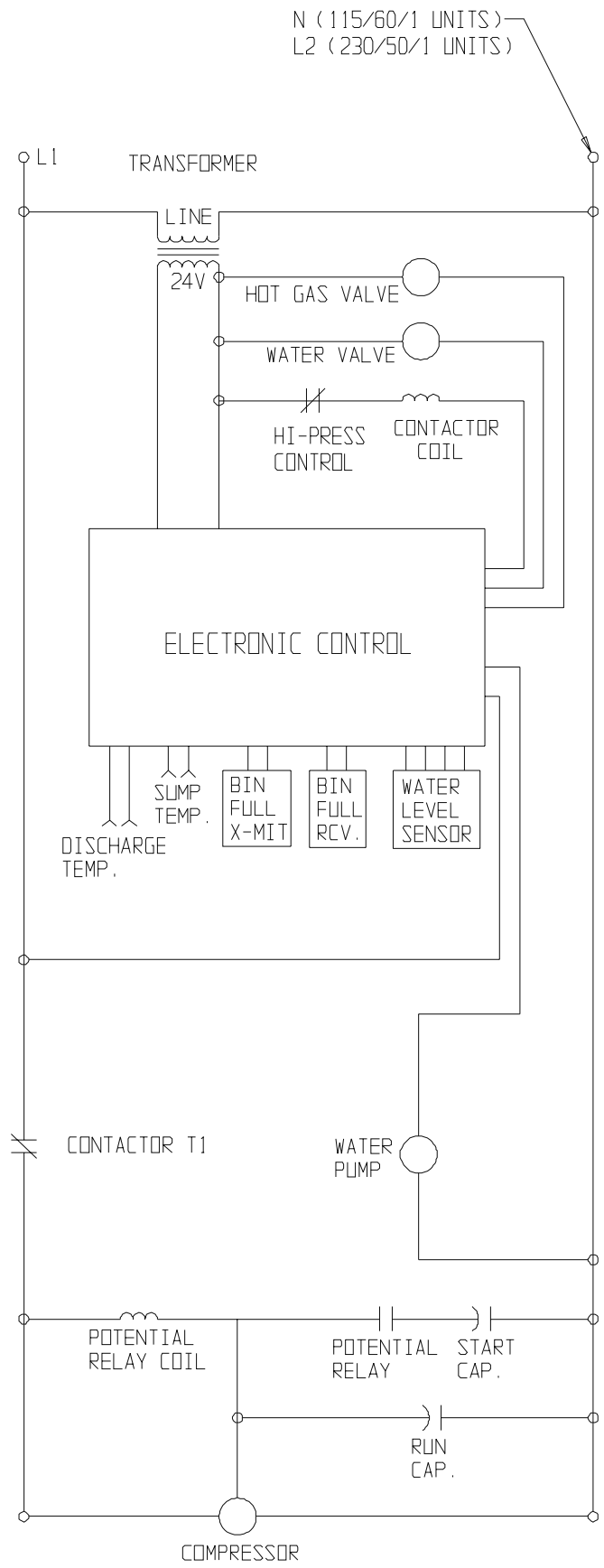

CME256 or CME506 or CME656 or CME806 Service Parts

A - C Series CME256 and CME506 Water Cooled Wiring Diagram

A36670-001

USE COPPER CONDUCTORS ONLY

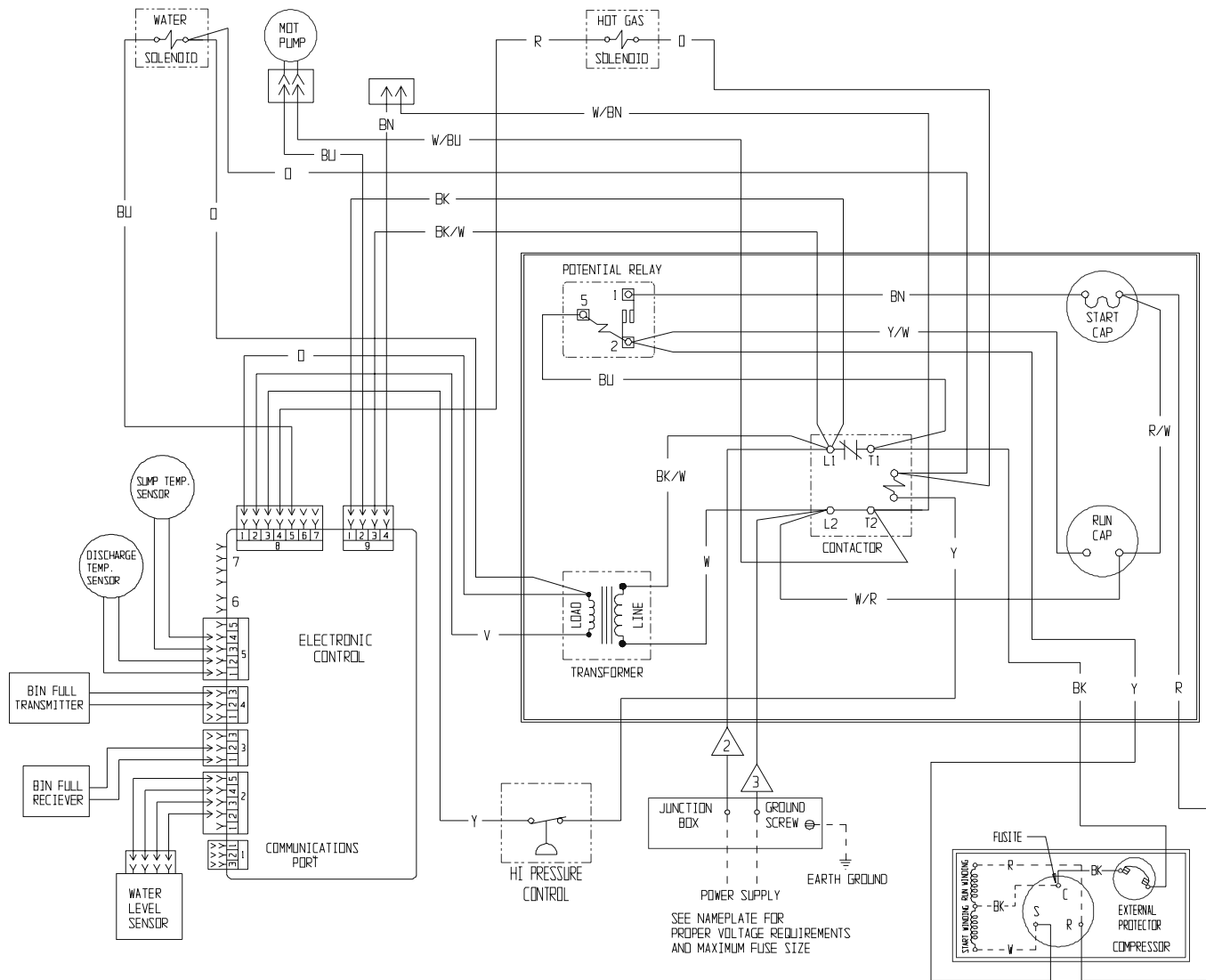

THIS UNIT MUST  
BE GROUND.

CAUTION:  
MORE THAN ONE DISCONNECT MEANS MAY BE  
REQUIRED TO DISCONNECT ALL POWER TO THIS UNIT.

**CME256 or CME506 or CME656 or CME806 Service Parts**

**A - C Series CME656 or CME806 Air Cooled Single Phase Wiring Diagram**

A36659-001

USE COPPER CONDUCTORS ONLY

⚠ DASHED LINES INDICATE FIELD WIRING WHICH MUST BE INSTALLED IN ACCORDANCE WITH THE NATIONAL ELECTRICAL CODE AND ALL STATE AND LOCAL CODES.

⚠ WIRE COLOR FOR 208-230/60/1 UNITS: BLACK  
WIRE COLOR FOR 230/50/1 UNITS : BROWN

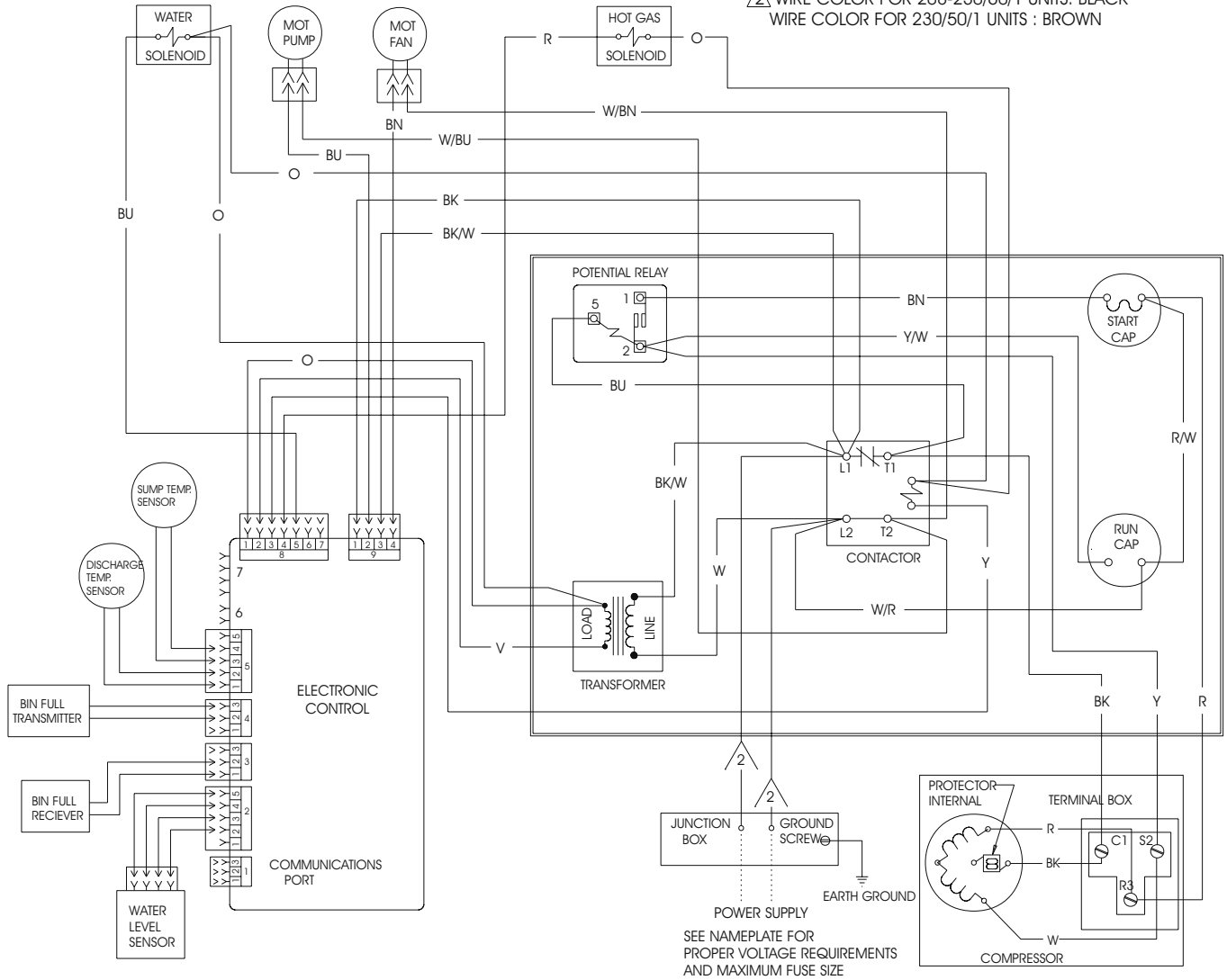

THIS UNIT MUST  
BE GROUNDED.

CAUTION:  
MORE THAN ONE DISCONNECT MEANS MAY BE  
REQUIRED TO DISCONNECT ALL POWER TO THIS UNIT.

CME256 or CME506 or CME656 or CME806 Service Parts

A - C Series CME656 Water Cooled Single Phase Wiring Diagram

A36662-001

USE COPPER CONDUCTORS ONLY

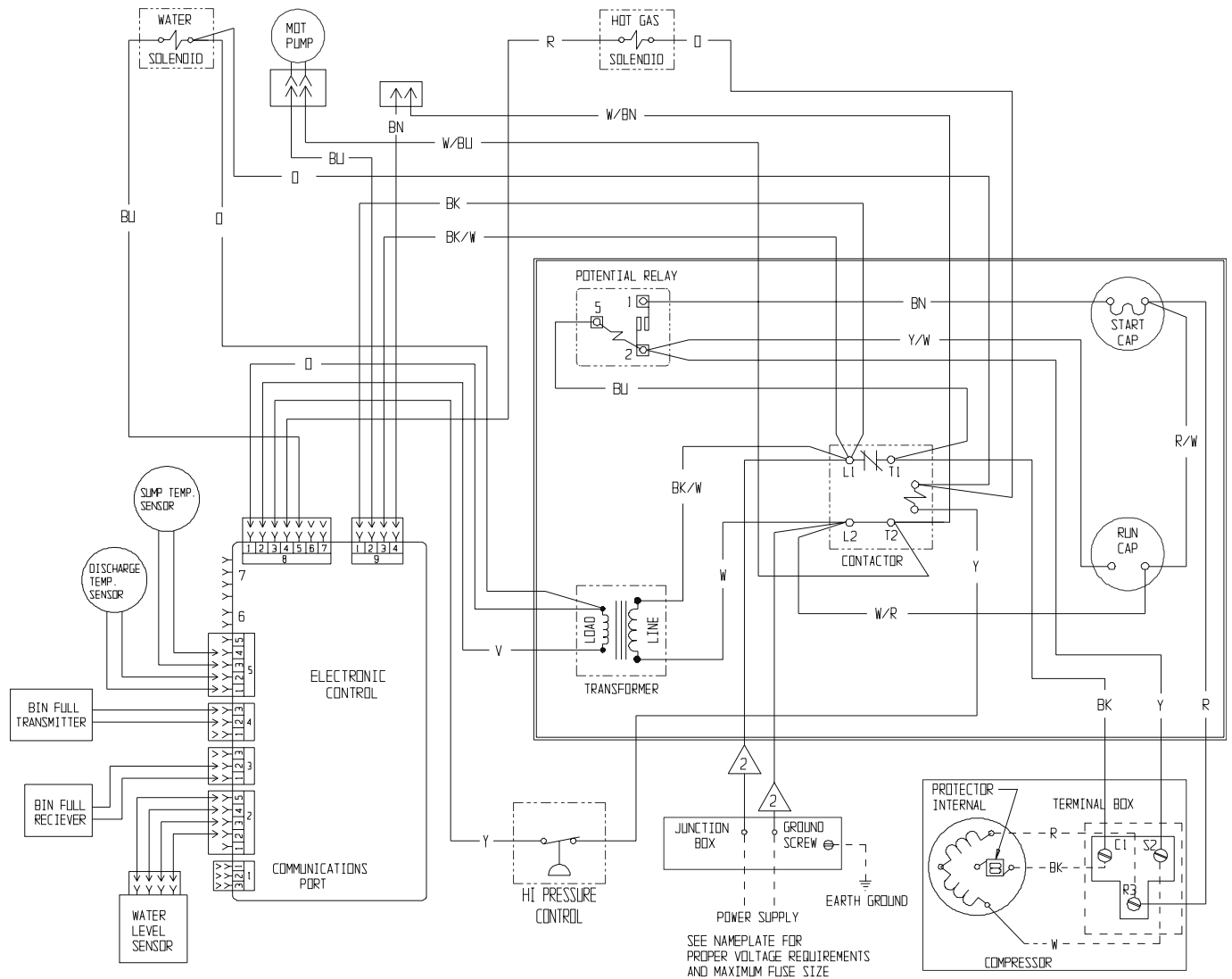

CAUTION:

MORE THAN ONE DISCONNECT MEANS MAY BE REQUIRED TO DISCONNECT ALL POWER TO THIS UNIT.

THIS UNIT MUST BE GROUNDED.

A - F Series Three Phase Air Cooled Schematic Diagram

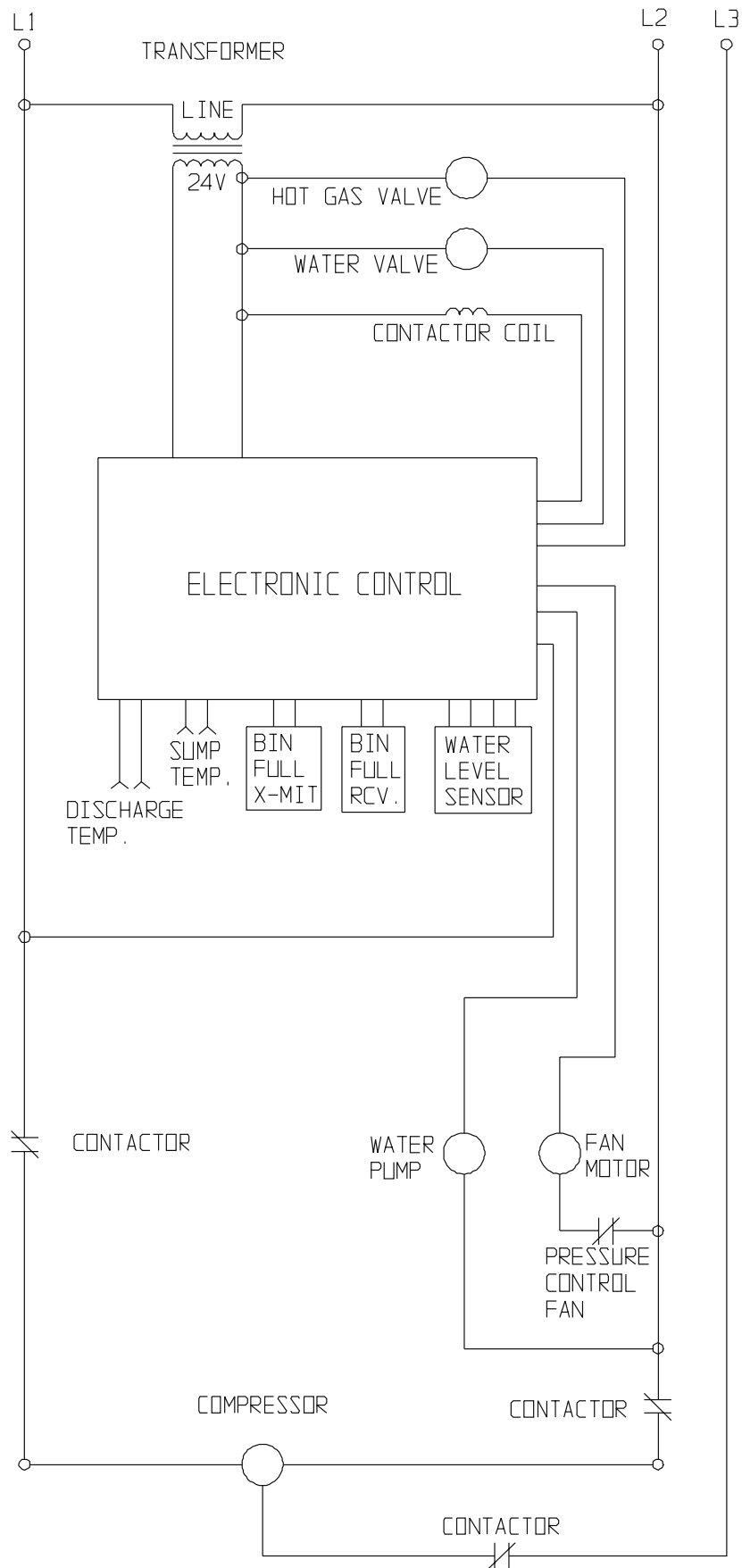

CME256 or CME506 or CME656 or CME806 Service Parts

A - C Series CME656 Air Cooled Three Phase Wiring Diagram

A36992-003

USE COPPER CONDUCTORS ONLY

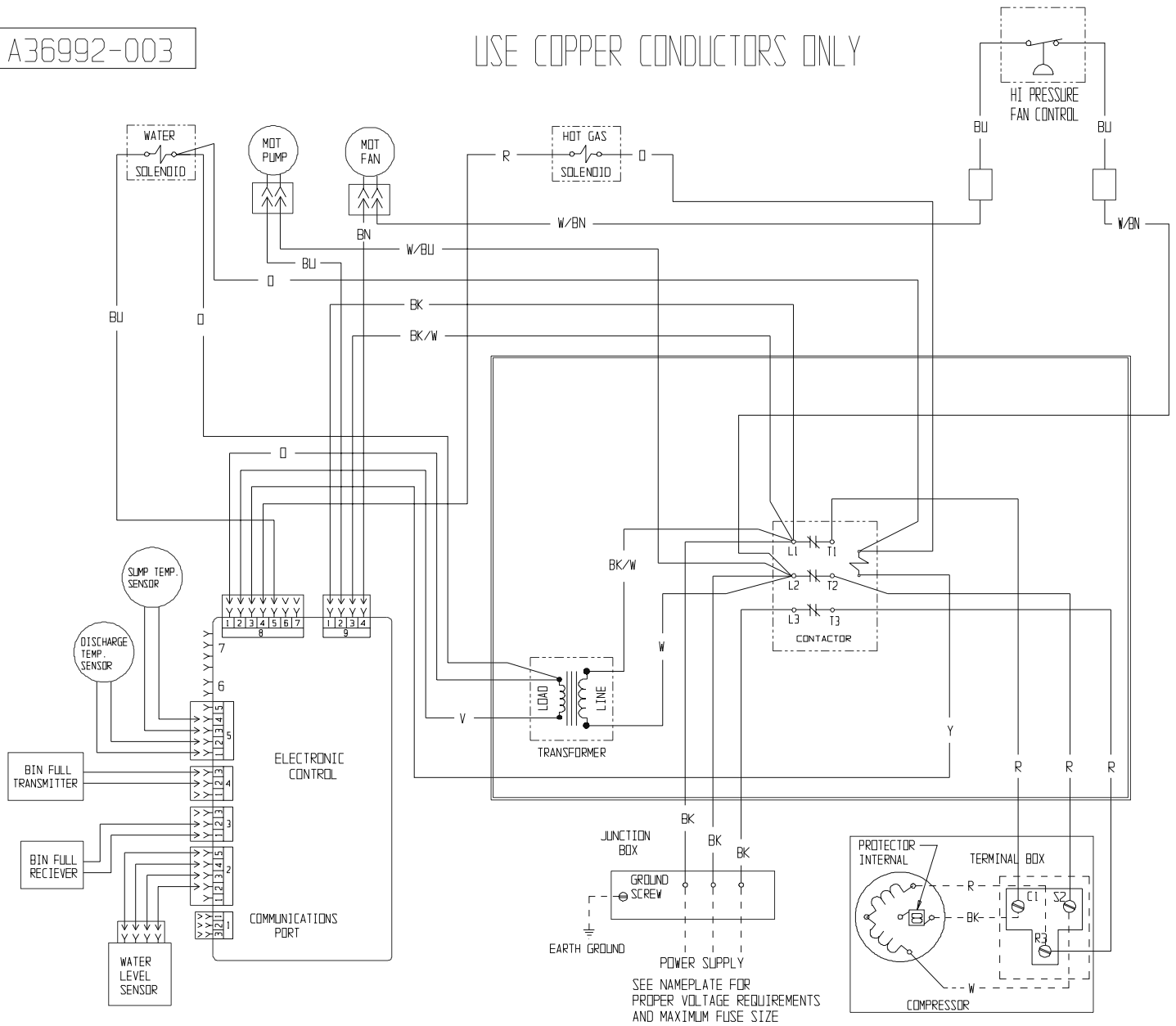

CAUTION:  
MORE THAN ONE DISCONNECT MEANS MAY BE  
REQUIRED TO DISCONNECT ALL POWER TO THIS UNIT.

THIS UNIT MUST  
BE GROUNDED.

- ① DASHED LINES INDICATE FIELD WIRING WHICH MUST BE INSTALLED IN ACCORDANCE WITH THE NATIONAL ELECTRICAL CODE AND ALL STATE AND LOCAL CODES.
- ② WIRE COLOR FOR 208-230/60/1 UNITS: BLACK  
WIRE COLOR FOR 230/50/1 UNITS : BROWN

A - F Series CME656 Three Phase Water Cooled Schematic Diagram

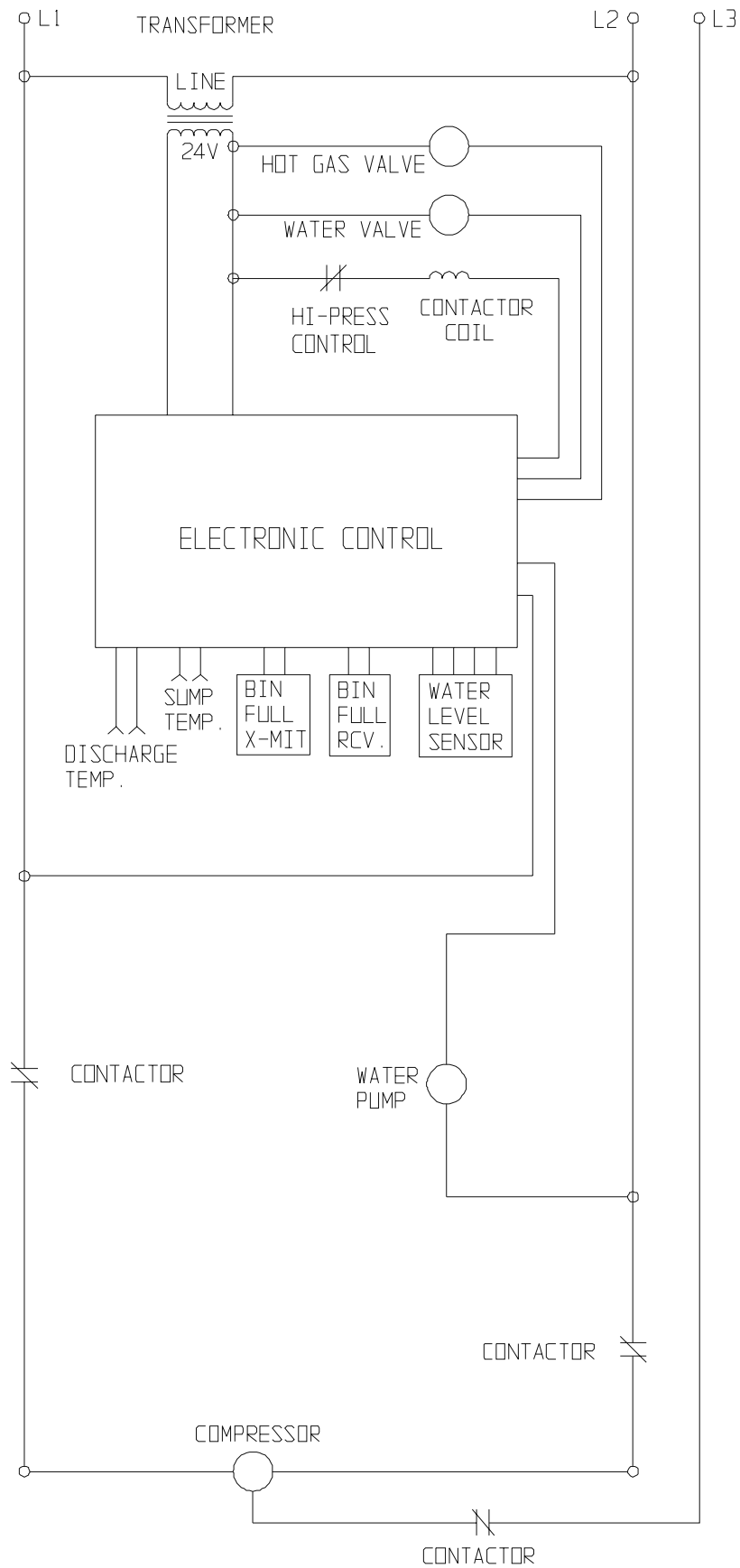

CME256 or CME506 or CME656 or CME806 Service Parts

A - C Series CME656 Three Phase Water Cooled Wiring Diagram

A36662-003

USE COPPER CONDUCTORS ONLY

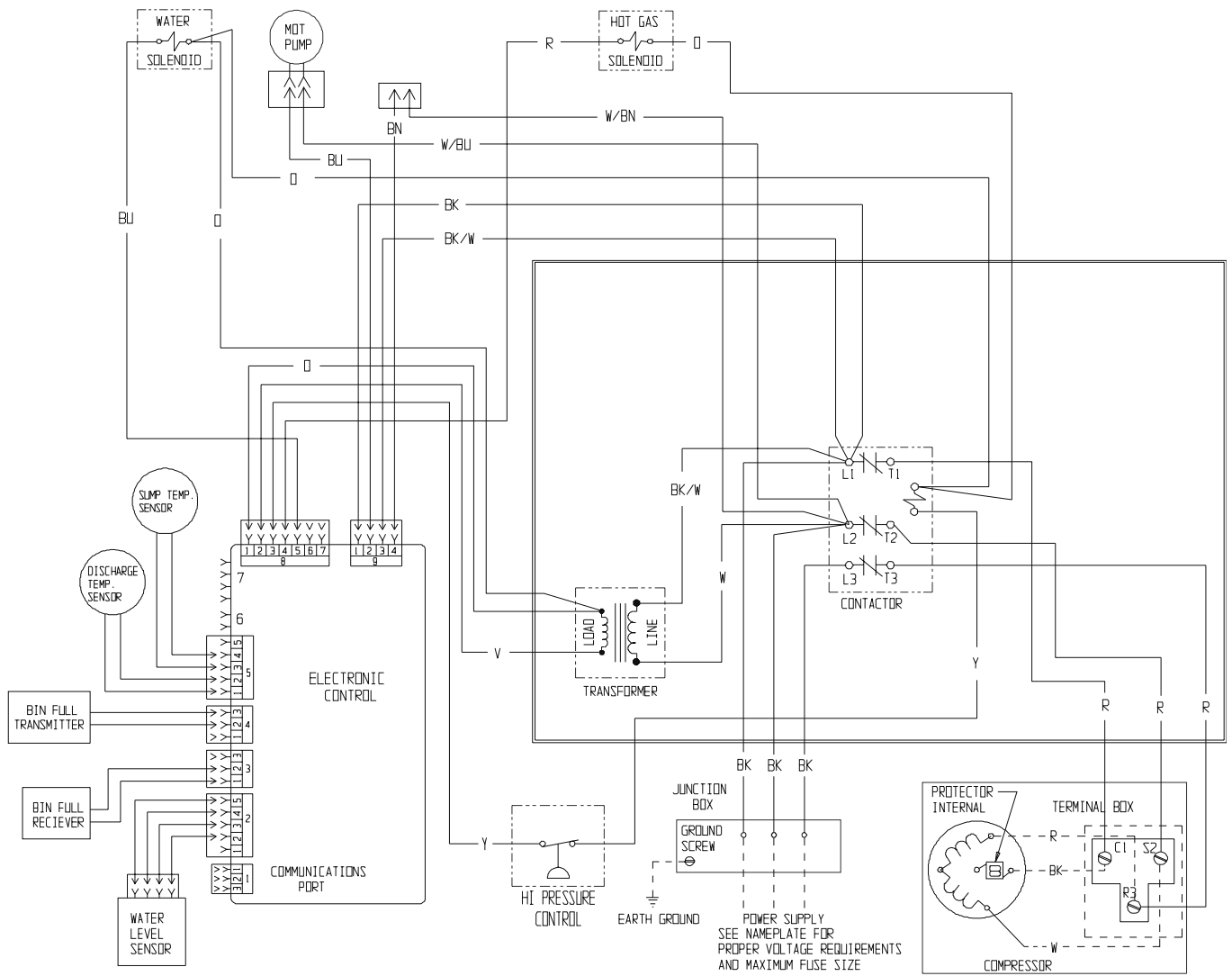

CAUTION:  
 MORE THAN ONE DISCONNECT MEANS MAY BE  
 REQUIRED TO DISCONNECT ALL POWER TO THIS UNIT.

THIS UNIT MUST  
 BE GROUNDED.



CME256 or CME506 or CME656 or CME806 Service Parts

D thru F Series CME506 50 Hz Air Cooled Diagram

USE COPPER CONDUCTORS ONLY

▲ DASHED LINES INDICATE FIELD WIRING WHICH MUST BE INSTALLED IN ACCORDANCE WITH THE NATIONAL ELECTRICAL CODE AND ALL STATE AND LOCAL CODES.

CAUTION: PTCR WILL BE HOT. COMPRESSOR MAY NOT START IF PTCR IS NOT ALLOWED TO COOL.

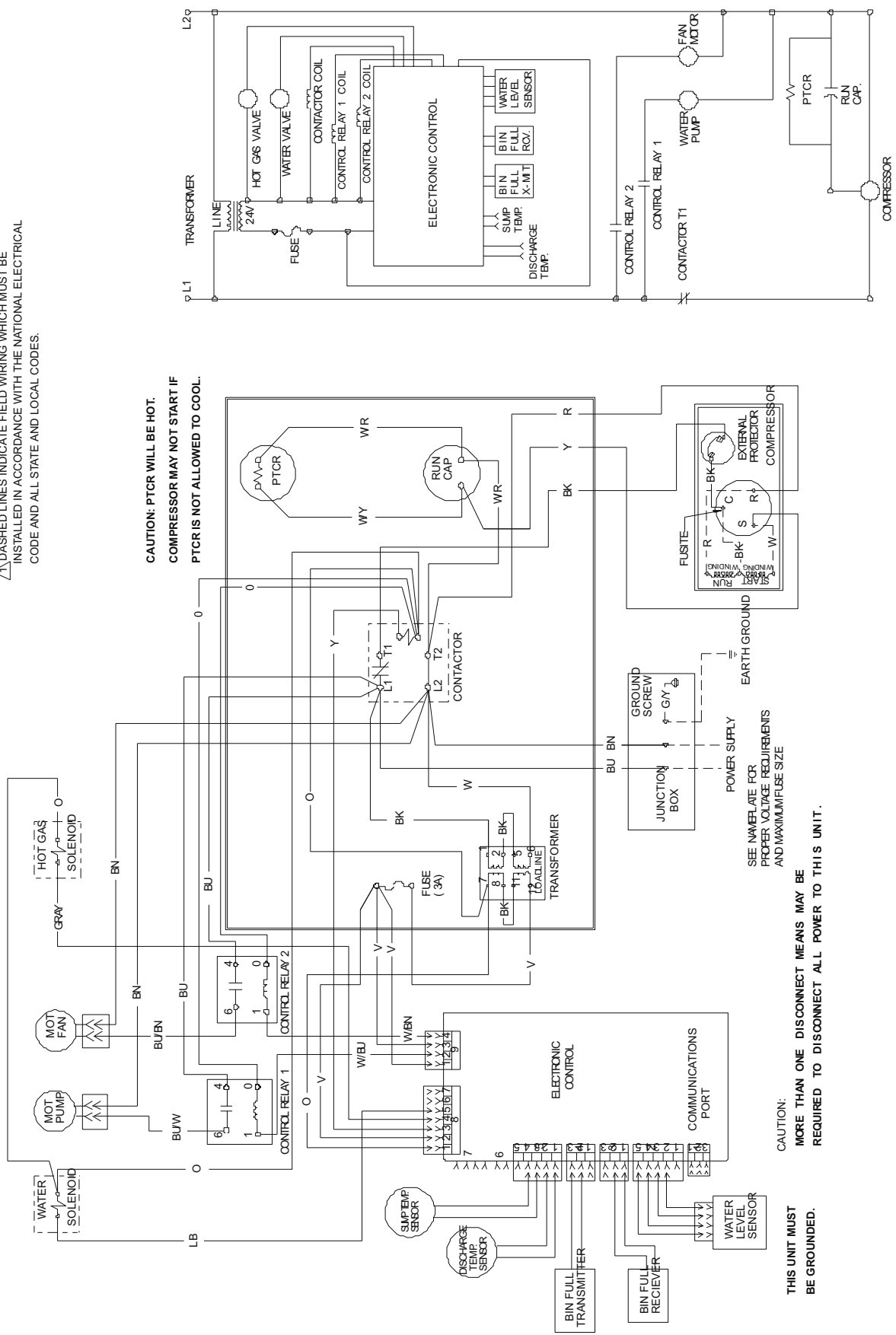

THIS UNIT MUST BE GROUNDED.  
 CAUTION: MORE THAN ONE DISCONNECT MEANS MAY BE REQUIRED TO DISCONNECT ALL POWER TO THIS UNIT.  
 SEE NAMEPLATE FOR PROPER VOLTAGE REQUIREMENTS AND MAXIMUM FUSE SIZE

CME256 or CME506 or CME656 or CME806 Service Parts

D thru F Series CME506 50 Hz Water Cooled Diagram

▲ DASHED LINES INDICATE FIELD WIRING WHICH MUST BE INSTALLED IN ACCORDANCE WITH THE NATIONAL ELECTRICAL CODE AND ALL STATE AND LOCAL CODES.

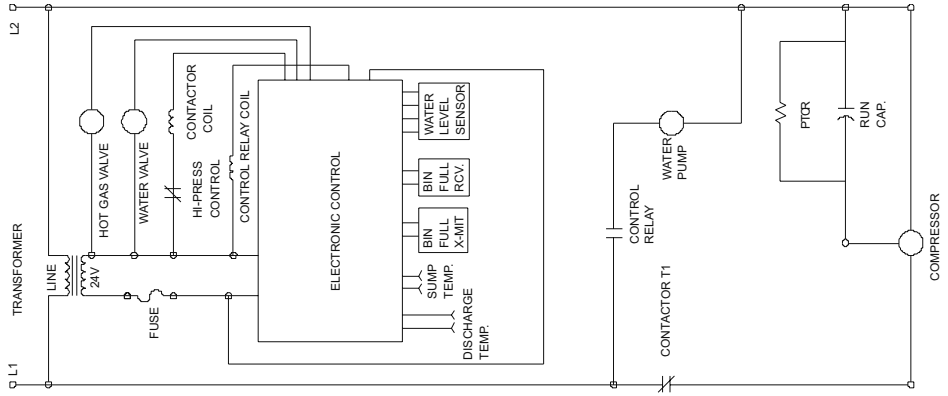

USE COPPER CONDUCTORS ONLY

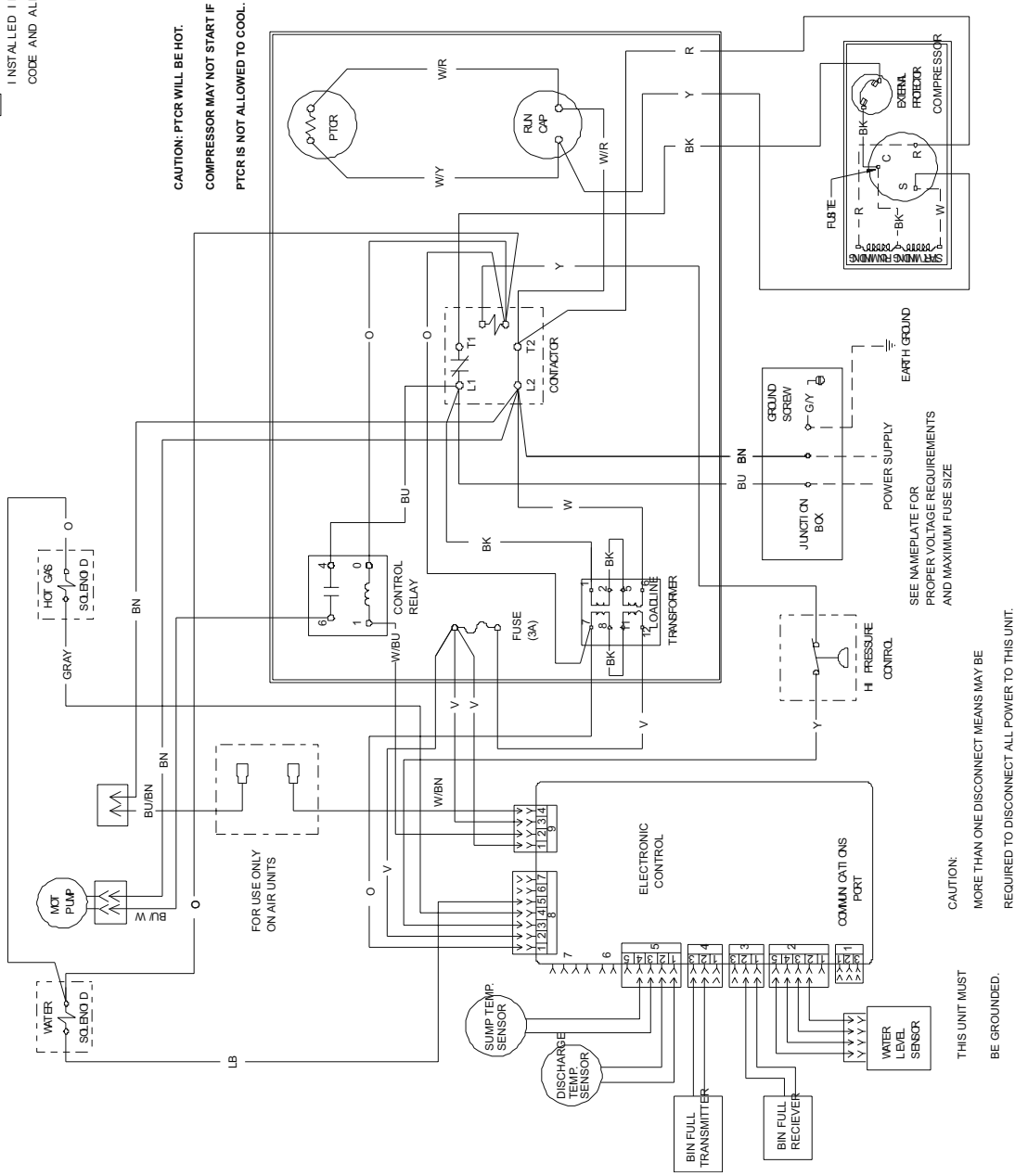

CAUTION: PTCR WILL BE HOT.  
COMPRESSOR MAY NOT START IF  
PTCR IS NOT ALLOWED TO COOL.

SEE NAMEPLATE FOR  
PROPER VOLTAGE REQUIREMENTS  
AND MAXIMUM FUSE SIZE

CAUTION:  
MORE THAN ONE DISCONNECT MEANS MAY BE  
REQUIRED TO DISCONNECT ALL POWER TO THIS UNIT.

THIS UNIT MUST  
BE GROUNDED.

17-2750-01

CME256 or CME506 or CME656 or CME806 Service Parts

D thru F Series CME656 or CME806 50 Hz Air Cooled Diagram

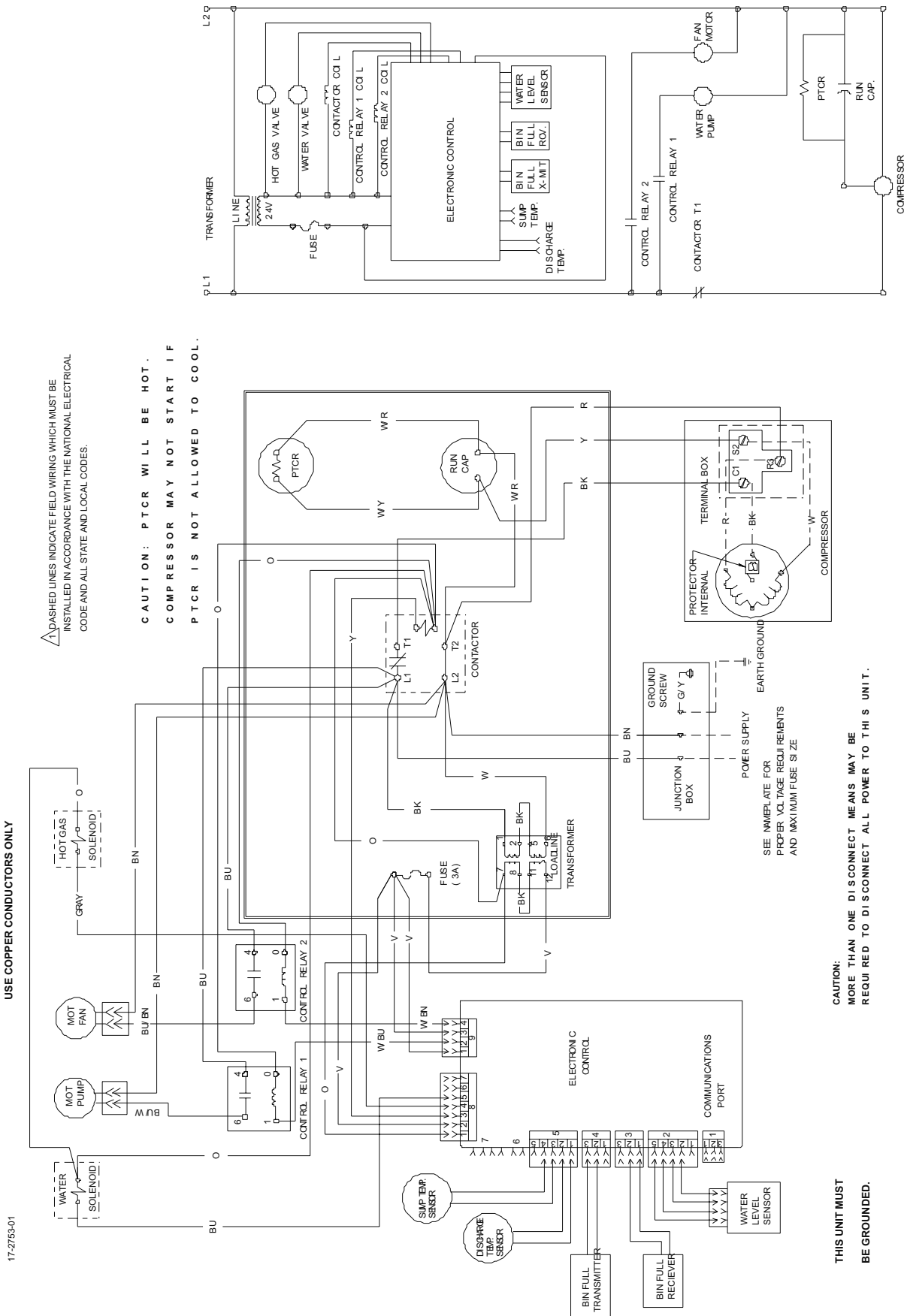

CME256 or CME506 or CME656 or CME806 Service Parts

D thru F Series CME656 or CME806 50 Hz Water Cooled Diagram

17-2754-01

USE COPPER CONDUCTORS ONLY

▲ DASHED LINES INDICATE FIELD WIRING WHICH MUST BE INSTALLED IN ACCORDANCE WITH THE NATIONAL ELECTRICAL CODE AND ALL STATE AND LOCAL CODES.

CAUTION: PTCR WILL BE HOT.  
COMPRESSOR MAY NOT START IF PTCR IS NOT ALLOWED TO COOL.

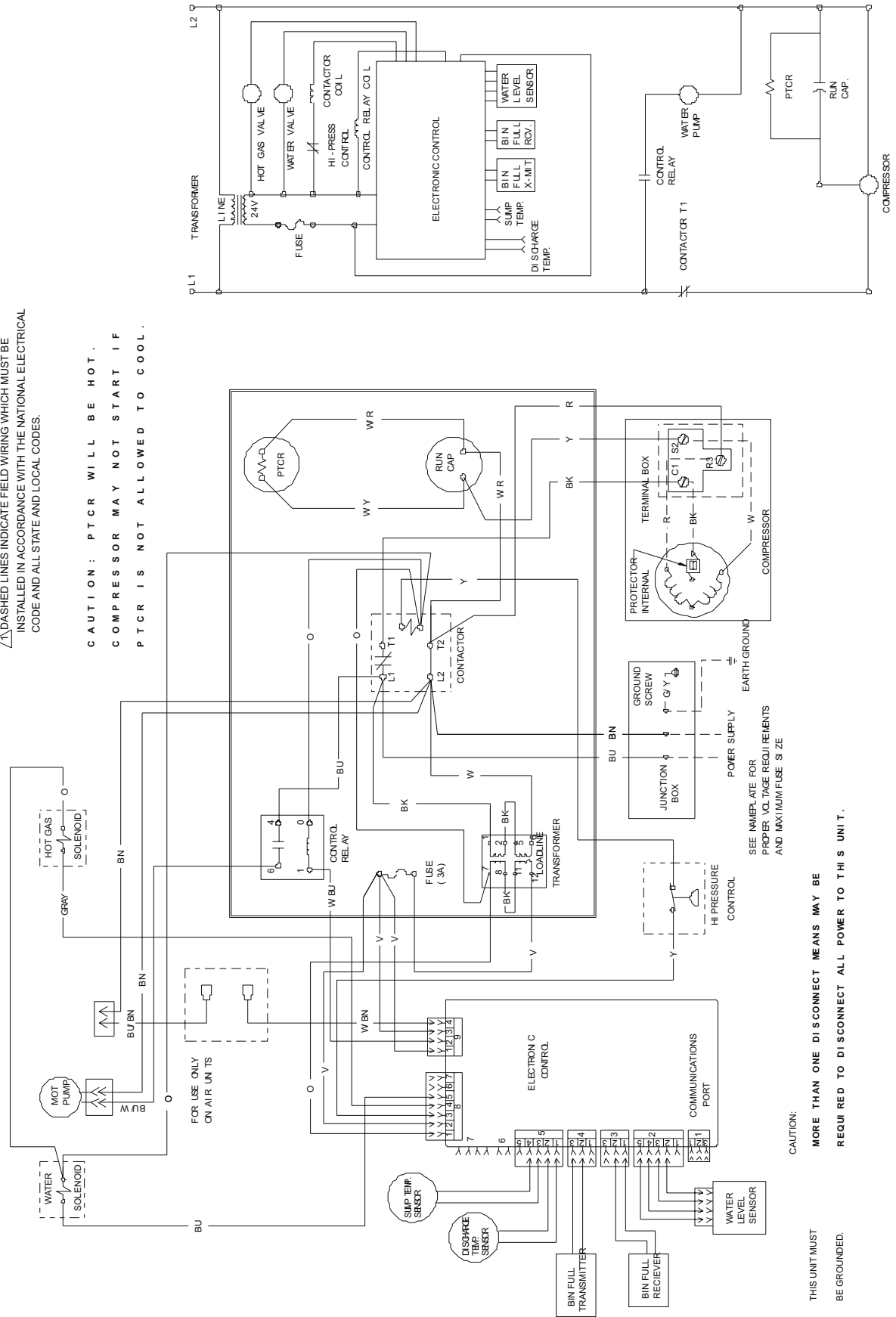

CAUTION: MORE THAN ONE DISCONNECT MEANS MAY BE REQUIRED TO DISCONNECT ALL POWER TO THIS UNIT.

THIS UNIT MUST BE GROUNDED.

CME256 or CME506 or CME656 or CME806 Service Parts

B or C Series 50 Hz Water Cooled CME506 Diagram

▲ DASHED LINES INDICATE FIELD WIRING WHICH MUST BE INSTALLED IN ACCORDANCE WITH THE NATIONAL ELECTRICAL CODE AND ALL STATE AND LOCAL CODES.

USE COPPER CONDUCTORS ONLY

17-2484-01

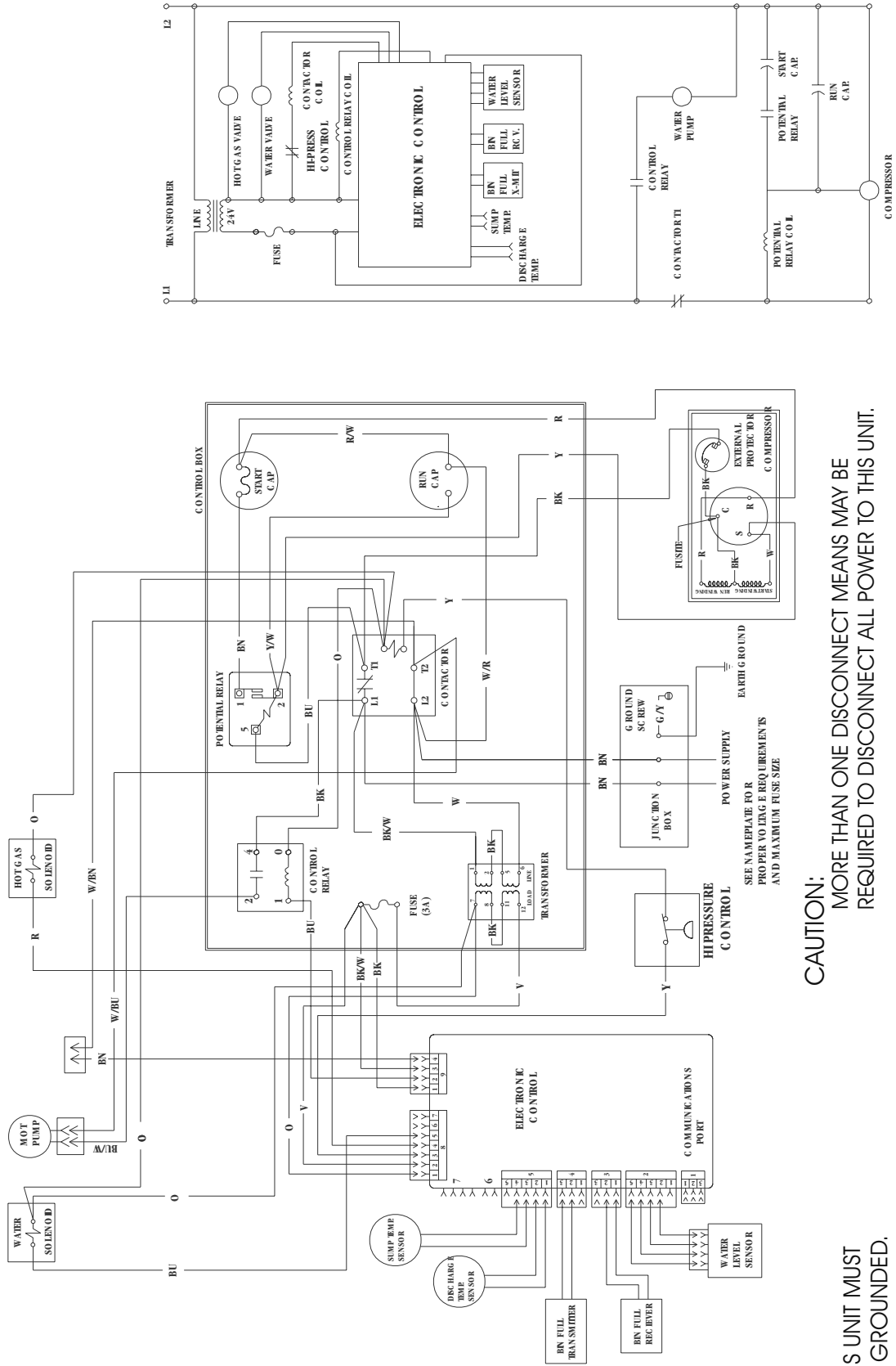

**CAUTION:**  
 MORE THAN ONE DISCONNECT MEANS MAY BE  
 REQUIRED TO DISCONNECT ALL POWER TO THIS UNIT.

THIS UNIT MUST  
 BE GROUND.

B or C Series, 50 Hz Air Cooled CME656 and CME806 Diagram

17-2485-01

USE COPPER CONDUCTORS ONLY

DASHED LINES INDICATE FIELD WIRING WHICH MUST BE INSTALLED IN ACCORDANCE WITH THE NATIONAL ELECTRICAL CODE AND ALL STATE AND LOCAL CODES.

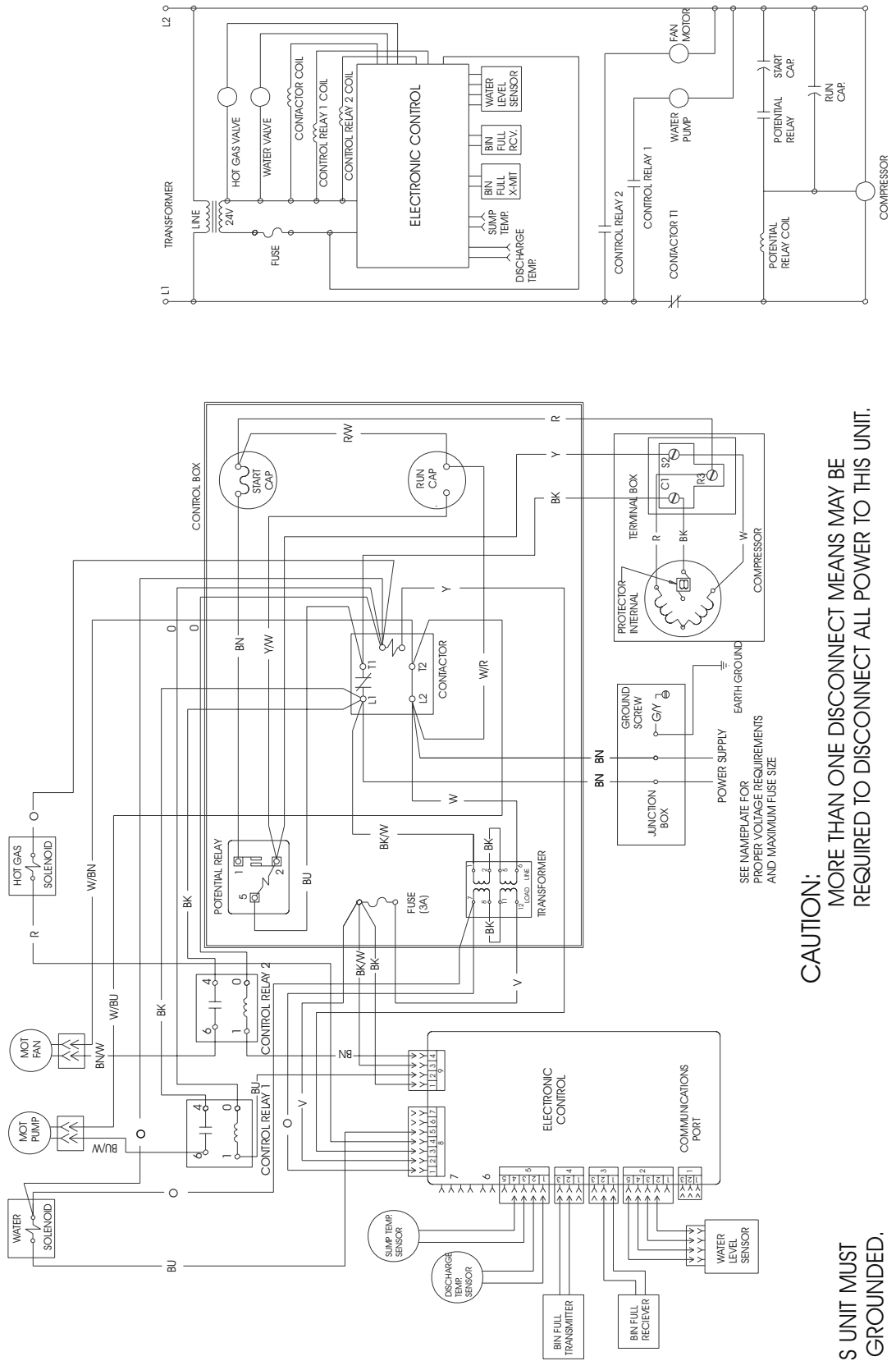

**CAUTION:**  
MORE THAN ONE DISCONNECT MEANS MAY BE REQUIRED TO DISCONNECT ALL POWER TO THIS UNIT.

THIS UNIT MUST BE GROUNDED.

B or C Series, 50 Hz Water Cooled CME656 and CME806 Diagram

▲ DASHED LINES INDICATE FIELD WIRING WHICH MUST BE INSTALLED IN ACCORDANCE WITH THE NATIONAL ELECTRICAL CODE AND ALL STATE AND LOCAL CODES.

USE COPPER CONDUCTORS ONLY

17-2593-01

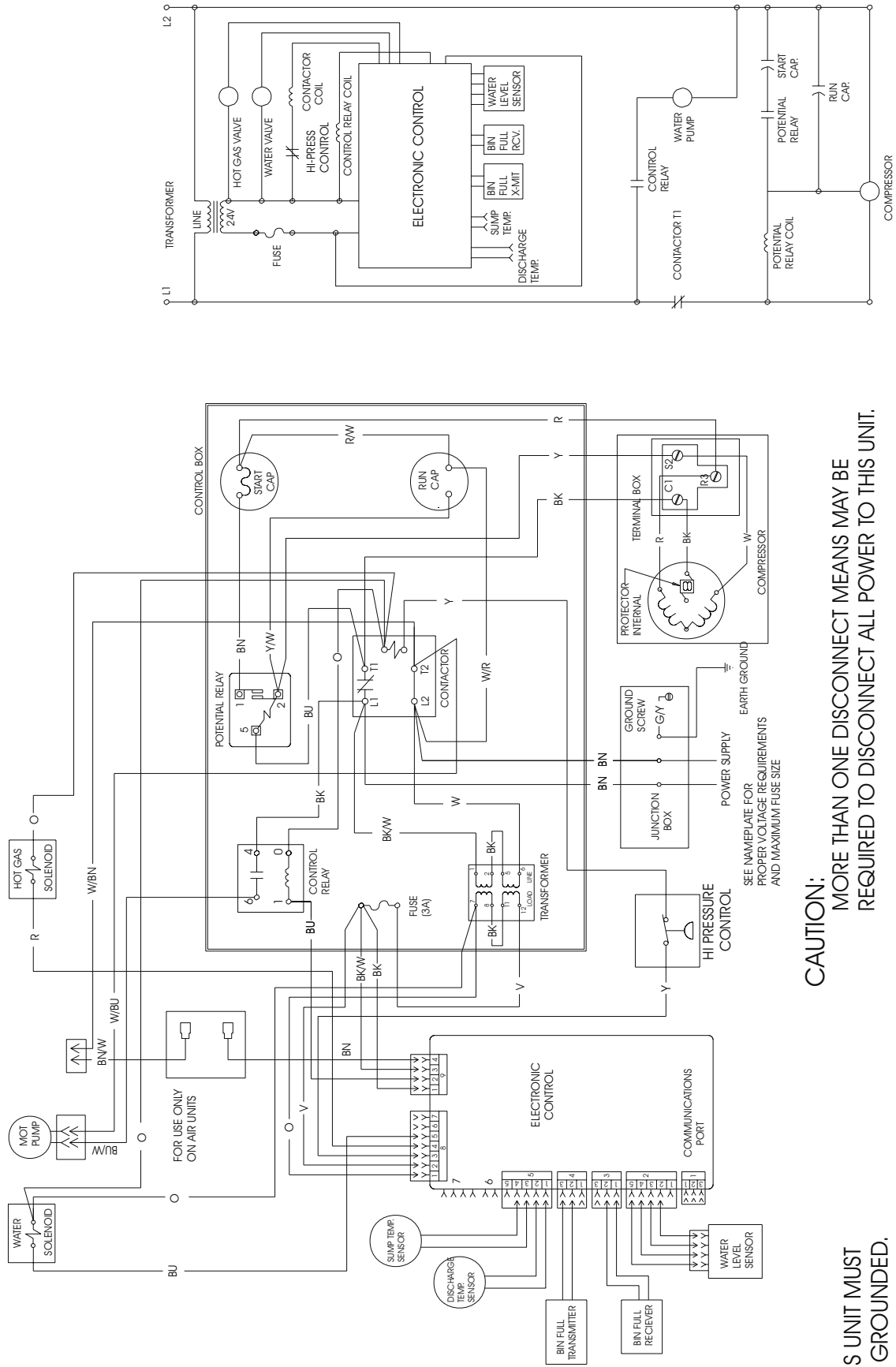

**CAUTION:**  
MORE THAN ONE DISCONNECT MEANS MAY BE REQUIRED TO DISCONNECT ALL POWER TO THIS UNIT.

THIS UNIT MUST BE GROUNDED.

B or C Series, 50 Hz Air Cooled CME506 Diagram

17-2592-01

USE COPPER CONDUCTORS ONLY

⚠ DASHED LINES INDICATE FIELD WIRING WHICH MUST BE INSTALLED IN ACCORDANCE WITH THE NATIONAL ELECTRICAL CODE AND ALL STATE AND LOCAL CODES.

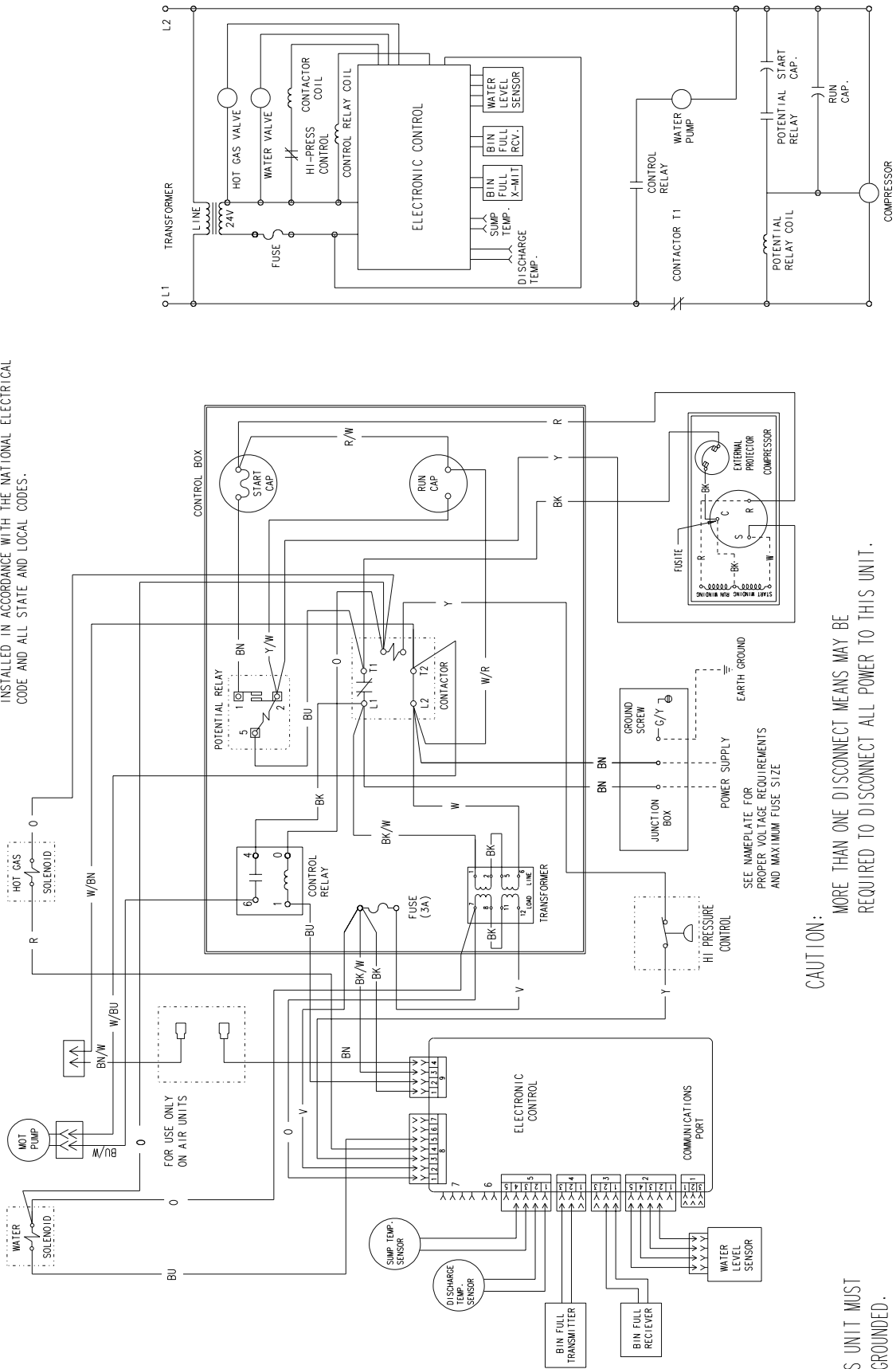

THIS UNIT MUST BE GROUNDED.

CAUTION: MORE THAN ONE DISCONNECT MEANS MAY BE REQUIRED TO DISCONNECT ALL POWER TO THIS UNIT.

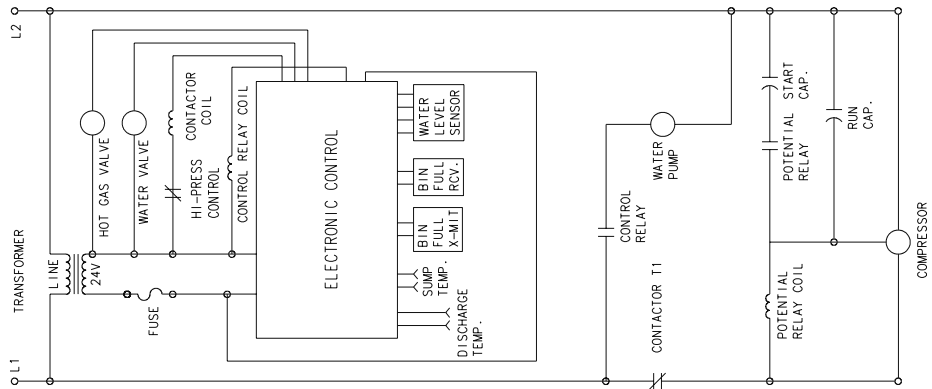



D thru F Series, 50 Hz CME256 Diagram

△ DASHED LINES INDICATE FIELD WIRING WHICH MUST BE INSTALLED IN ACCORDANCE WITH THE NATIONAL ELECTRICAL CODE AND ALL STATE AND LOCAL CODES.

USE COPPER CONDUCTORS ONLY

17-2816-01

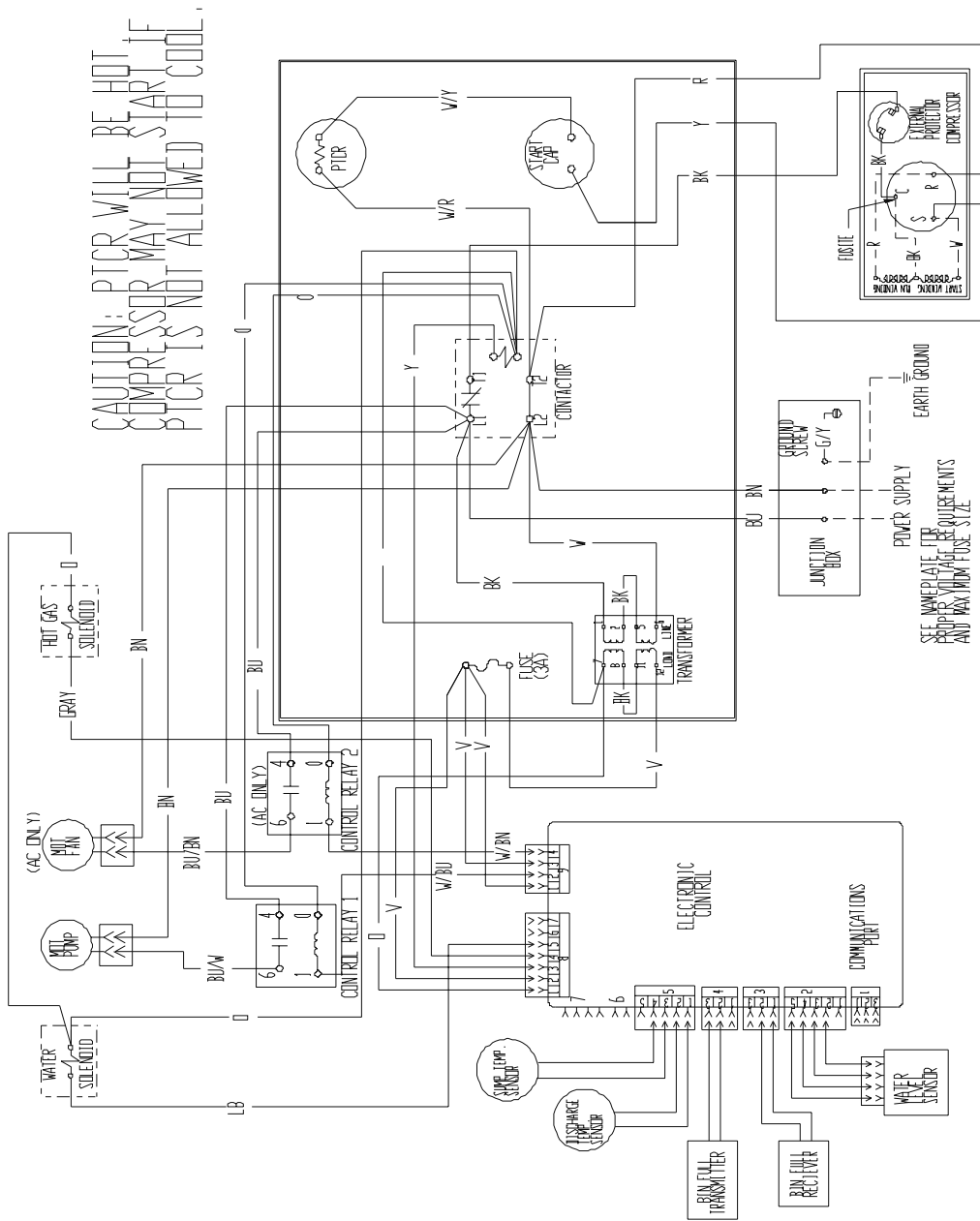

CAUTION: PTCR WILL BE HOT IF COMPRESSOR MAY NOT START IF PTCR IS NOT ALLOWED TO COOL.

CAUTION: MORE THAN ONE DISCONNECT MEANS MAY BE REQUIRED TO DISCONNECT ALL POWER TO THIS UNIT.

THIS UNIT MUST BE GROUND.

