

# MF400 SERVICE PARTS

This is the parts list for all MF400 model units.

There are two very different models, the first was the MF400 "A" series, as in MF400AE-1**A**. This unit was produced from 1978 until early 1989. In the spring of 1989, the MF400 "B" (MF400AE-1**B**) series production began. The **complete** model number must be checked, especially when ordering evaporator and ice spout parts.

## Table Of Contents

Major Assemblies .....	Page 2-3
Cabinet .....	Page 4
Compressor .....	Page 5
Spout .....	Page 6
Evaporator "B" Model .....	Page 7
Evaporator "A" Model .....	Page 8
Gearmotor .....	Page 9
Control Box .....	Page 10
Wiring Diagrams .....	Page 11-14

# MF400 SERVICE PARTS

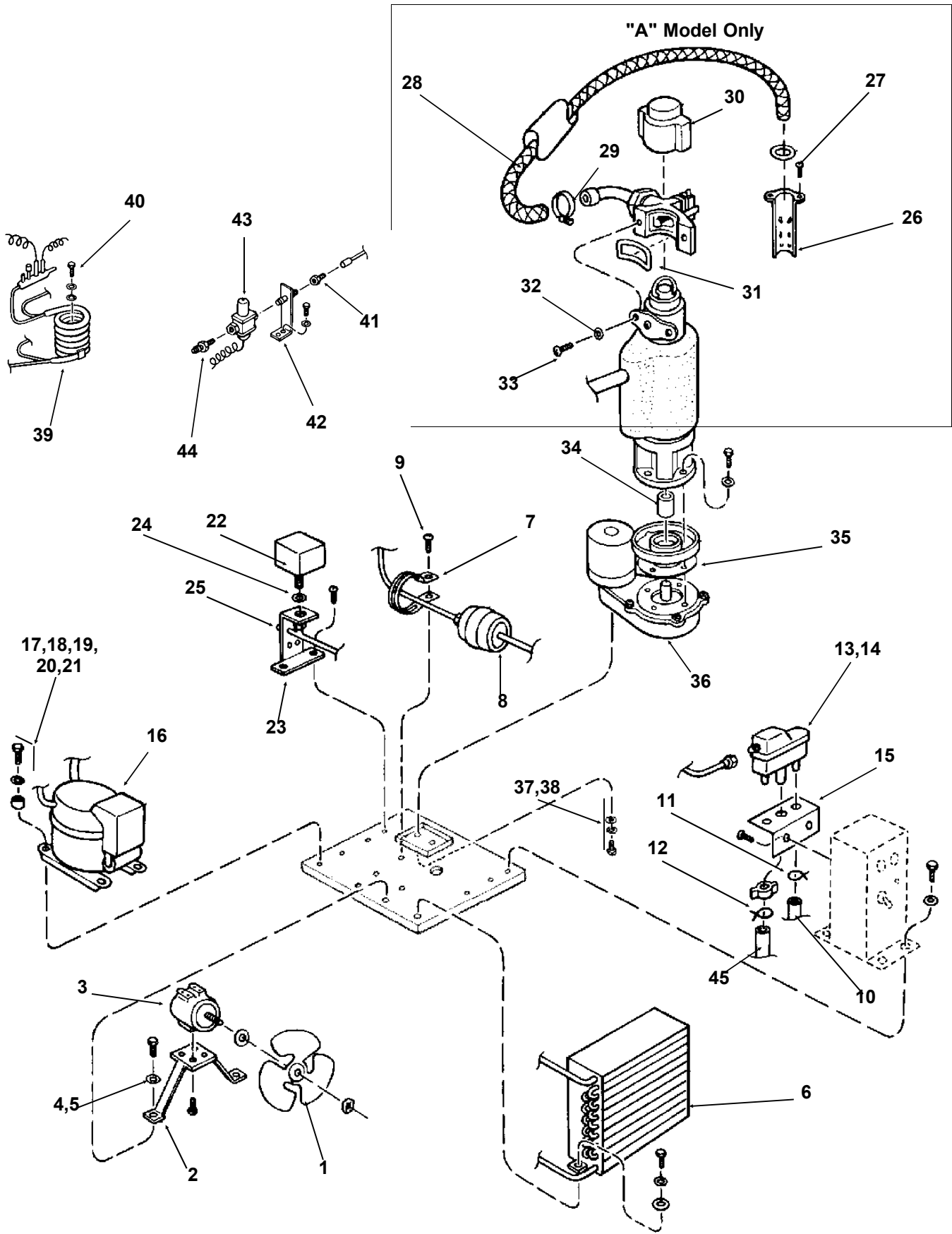

## MF400 SERVICE PARTS MAJOR ASSEMBLIES

ITEM NUMBER	PART NUMBER	DESCRIPTION
1.	18-3309-01	Fan Blade
2.	18-0422-00	Fan Motor Bracket
3.	12-1576-01	Fan Motor
4.	03-1417-09	Lockwasher
5.	03-0571-00	Hex Head Screw
6.	18-3717-01	Air Cooled Condenser
7.	A09386-000	Drier Brace
8.	02-2426-01	Drier
9.	03-1360-01	Mounting Screw
10.	13-0079-03	Reservoir Overflow Tube, order per ft.
11.	02-0535-01	Hose Clamp
12.	03-0694-00	Hose Clamp
13.	02-2217-01	Reservoir, Includes Valve
14.	02-2217-02	Valve Only, For Reservoir
15.	A20959-000	Mounting Bracket
16.	18-4500-01	Compressor
17.	18-2200-28	Grommet
18.	18-2200-27	Mounting Sleeve
19.	03-1417-12	Lockwasher
20.	03-1408-29	Special Washer
21.	03-1405-40	Mounting Screw
22.	11-0296-00	Low Water Pressure Control
23.	A27993-001	Utility Bracket
24.	13-0617-26	O-ring
25.	03-1394-00	Pal Nut
26.	A30487-001	Bin Thermo Bracket
27.	13-0806-01	Sealing Pad
28.	A26537-004	Ice Tube
29.	02-0179-02	Hose Clamp
30.	13-0815-01	Freezer Cap
31.	13-0679-00	Spout Gasket
32.	03-1417-07	Washer
33.	03-1544-03	Soc-hd Cap Screw
34.	A29915-002	Coupling
35.	13-0628-00	Gasket
36.	A31977-001	Complete Gearmotor
37.	03-1417-09	Lockwasher
38.	03-1405-03	Hex Hd Cap Screw
39.	18-3303-02	Water Cooled Condenser
40.	03-0571-00	Hex Hd Screw
41.	16-0677-01	Half Union
42.	A15924-000	Pipe Bracket/nipple Assmbly
43.	11-0198-02	Water Regulating Valve
44.	16-0355-00	Coupling
45.	13-0674-09	Reservoir tube, order per ft.

# MF400 SERVICE PARTS

## Cabinet

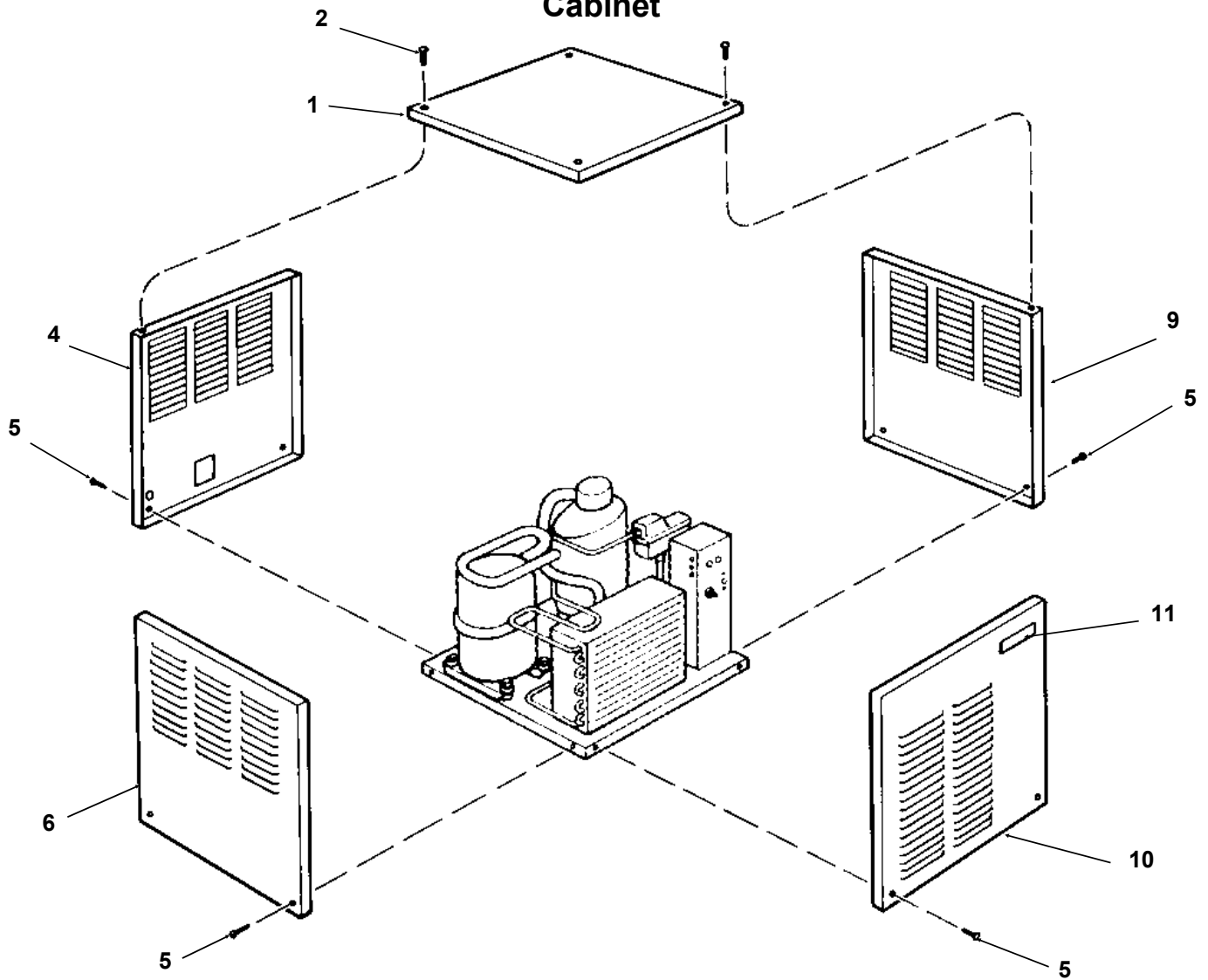

ITEM NUMBER	PART NUMBER	DESCRIPTION
1	A26625-003	Top panel, painted
	A26625-002	Top panel, stainless
2	03-1419-09	Flat head screw
3	03-1423-06	Speed nut
4	A28048-001	Back panel
	A28048-002	Back panel, stainless
5	03-1404-09	Panel Screw
6	A26623-003	Left side panel
7	A26623-003	Left side panel, stainless
8	03-1507-00	Speed nut
9	A26624-003	Right side panel
	A26624-002	Right side panel
10	A27111-003	Front panel, painted
	A27111-002	Front panel, stainless
11	15-0718-01	Emblem

# MF400 SERVICE PARTS

## Compressor

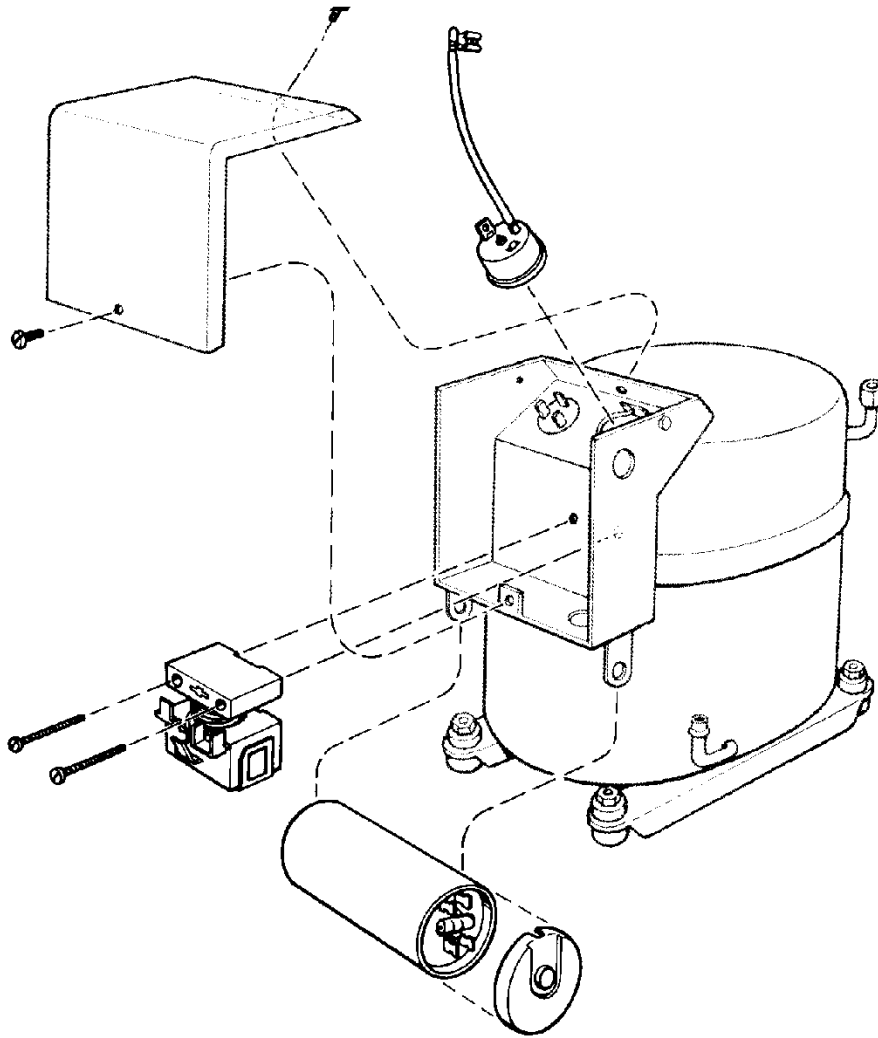

### COMPRESSOR

ITEM NUMBER	PART NUMBER	DESCRIPTION
1.	18-4500-01	Compressor
2.	18-1901-33	Start capacitor
3.	18-2200-25	Overload
4.	18-2200-26	Relay

# MF400 SERVICE PARTS

## "B" Model Spout

ITEM NUMBER	PART NUMBER	DESCRIPTION
1	05-0582-01	Ice Tube Assy (only for metal spout)
2	A34519-001	Bin Thermo Bracket
3	03-1587-02	Wing nut
4	no number	Spout*
5	A34704-001	Cap Assy (fits metal spout only)
6	13-0877-01	Grommet (use with plastic spouts only)
7	03-1403-46	Screws
8	12-1018-01	Microswitch
9	A34515-001	Speed nut
10	03-1403-09	Screw
11	A34700-001	Plate
12	A34516-001	Switch plate
13	A34522-001	Grommet (use with plastic spouts only)
14	02-3207-01	Upper spacer
15	02-3207-02	Lower spacer
16	02-3200-01	Spout insul. half
	02-3200-02	Spout insul. half

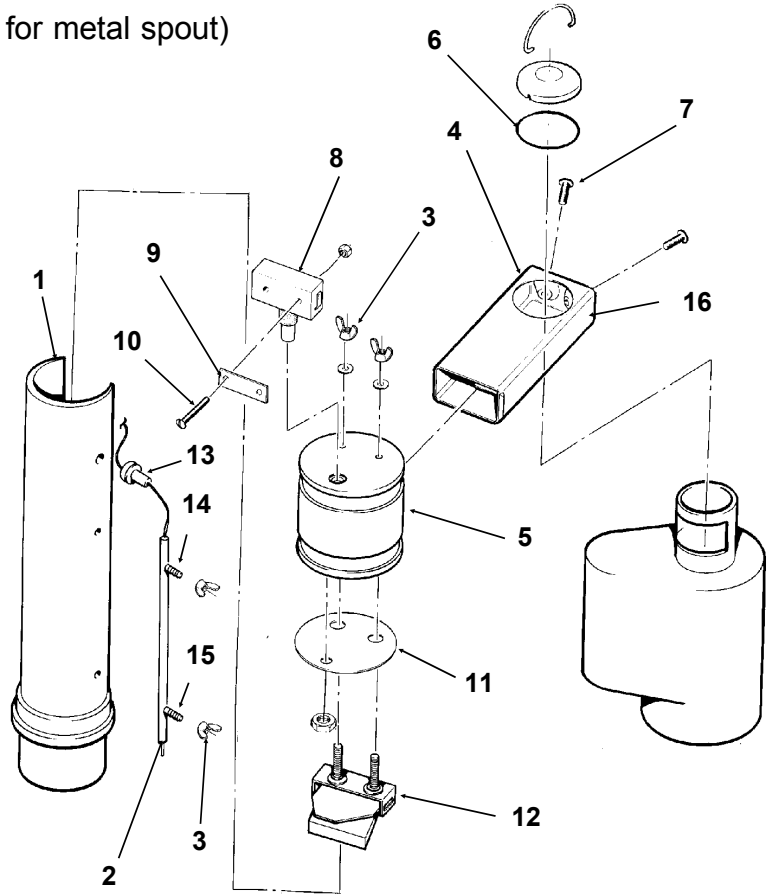

\*Kit to change early model units with plastic spout to current metal spout: A35350-001  
Change to metal spout began with May, 1991 production.

## "A" MODEL SPOUT

ITEM NUMBER	PART NUMBER	DESCRIPTION
1.	A26542-001	Ice Discharge elbow
2.	13-0617-41	O-ring
3.	12-1664-00	Switch
4.	03-1418-38	Screw
5.	03-1417-01	Lockwasher
6.	03-1406-01	Nut
7.	02-2377-01	Thermal Barrier
8.	03-1418-01	Screw
9.	A27511-001	Switch actuator
10.	A25305-001	Shoulder screw
11.	A24934-001	Spout Casting

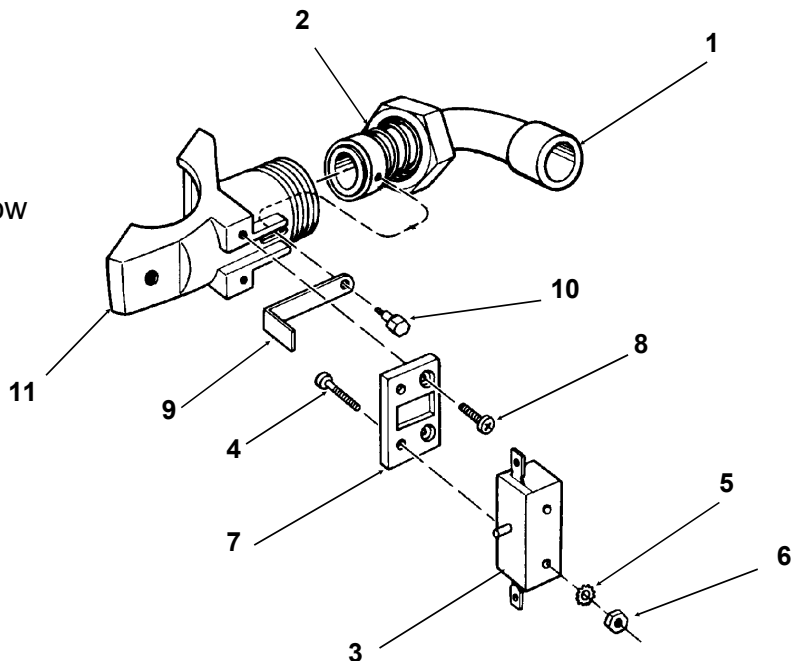

# MF400 SERVICE PARTS

## Evaporator for "B" series

ITEM NUMBER	PART NUMBER	DESCRIPTION
1	03-1558-03	Retainer Ring
2	A08162-000	Cap Hook
3	A07701-000	Cap
4	03-0758-00	Screw
5	A07699-000	Washer
6	02-1412-00	Top Bearing Set
7	13-0617-16	O-Ring
8	A14678-020	Breaker with Bearing Includes 6,7,8
9	A29669-001	Auger
10	02-1300-01	Water Seal
11	02-0417-00	Lower Bearing
12	A29915-002	Spline Coupling
13	03-1505-00	Gasket
14	03-1410-04	Washer (3)
15	03-1420-01	Cap Screw (3)
16	08-0595-01	Adapter
17	13-0709-01	Water shed
18	A34500-020	Evaporator**
19	03-1417-07	Washer
20	03-1403-46	Screw

\* Tapered bearing set, assembly is critical, refer to service manual for instructions.

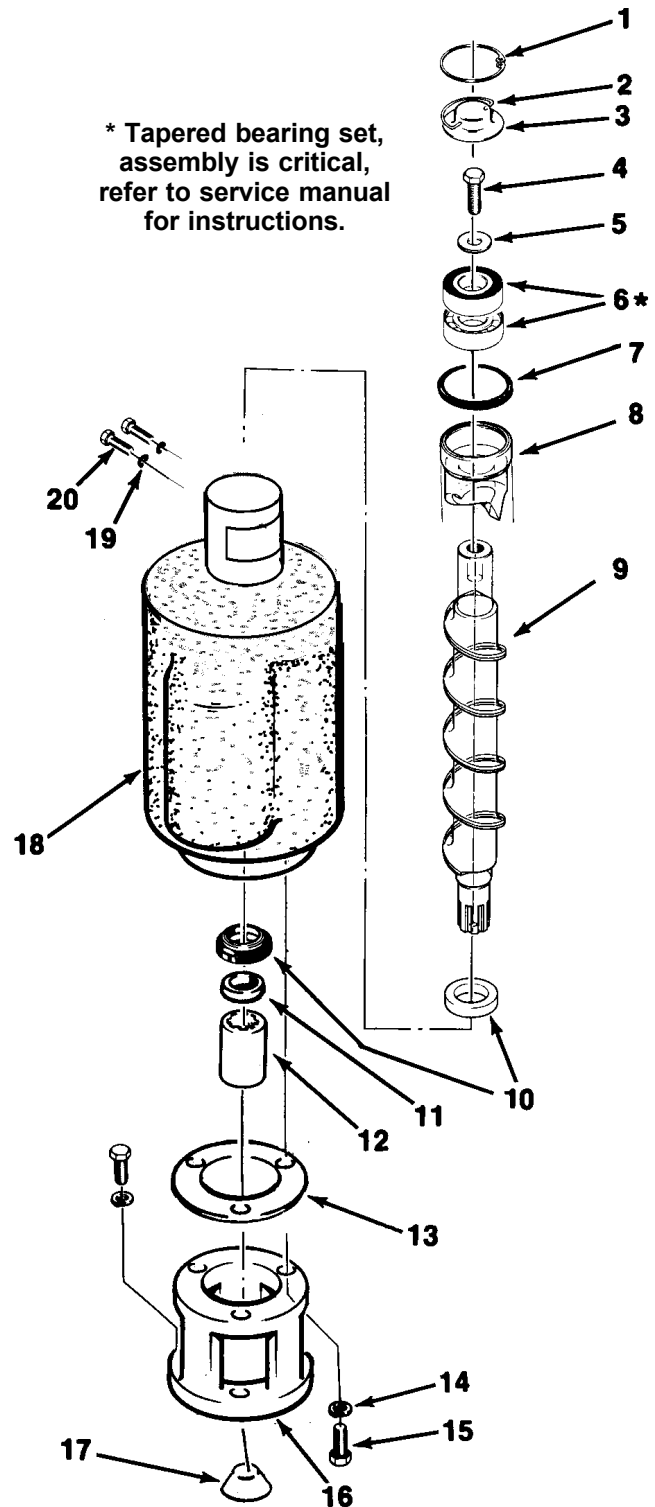

\*\* Not available as an assembly, but includes parts to change to metal spout design.

# MF400 SERVICE PARTS

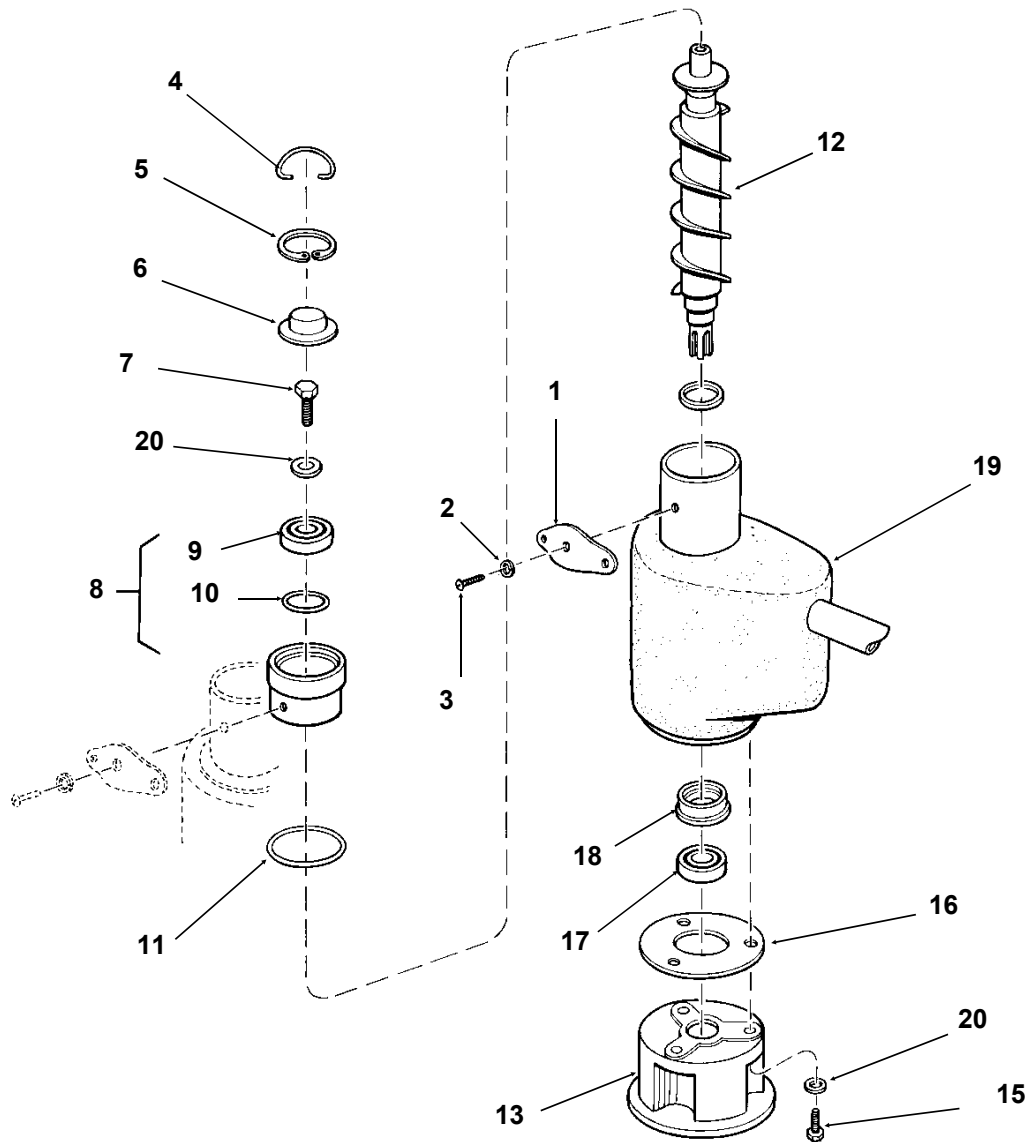

## "A " MODEL EVAPORATOR

ITEM NUMBER	PART NUMBER	DESCRIPTION	ITEM NUMBER	PART NUMBER	DESCRIPTION
1	A18430-002	Spout Plate	11.	13-0617-29	O-ring
2.	03-1409-14	Washer	12.	A29622-001	Auger
3.	03-1506-01	Sealing Screw	13.	08-0595-01	Adaptor
4.	A08162-000	Cap Hook	14.	03-1401-04	Lockwasher
5.	03-1558-03	Retaining Ring	15.	03-1420-01	Hex cap screw
6.	A07701-000	Cap	16.	03-1505-00	Gasket
7.	03-0758-00	Cap Screw	17.	02-0417-00	Bottom Bearing
8.	A26707-001	Bearing Retainer With Bearing	18.	02-1300-01	Water seal, two part set
9.	02-0695-00	Top Bearing	19.	A29344-020	Evaporator only*
10	13-0617-16	O-ring	20.	A07699-000.	Washer

\* Evaporator is not available as an assembled part. All parts must be ordered individually.



# MF400 SERVICE PARTS

## GEARMOTOR

ITEM NUMBER	PART NUMBER	DESCRIPTION
1.	12-2059-01	Switch
2.	A27895-001	Housing
3.	A27494-001	Centrifugal Sw. Kit
4.	03-1403-77	Screw
5.	A30579-001	Shaft and Actuator
6.	03-1408-36	Washer
7.	02-1503-00	Grease seal
	13-0841-01	Water shed, not illus
8.	03-1408-21	Washer
9.	03-1408-04	Washer
10.	02-2445-01	Output shaft
11.	03-1515-03	Retaining ring
12.	03-1602-01	Woodruff Key
13.	02-2444-01	Output gear
14.	02-1505-00	O-ring
15.	03-0774-11	Roll pin
16.	A28166-001	Gear Case
17.	03-1408-39	Washer
18.	03-1408-40	Washer shim
19.	02-2439-01	Second gear and third pinion
20.	03-1408-41	Washer
21.	03-1408-38	Washer
22.	02-2438-01	First gear and second pinion
23.	A28165-021	Gear box cover
24.	02-3969-20	Grease seal
25.	02-1501-00	Bearing
26.	03-1408-08	Washer
27.	A37707-021	Motor kit
28.	no number, part of item 27	
29.	A28168-001	Fan
30.	A38501-001	Motor Housing with bearing
31.	A25835-001	Oil
32.	A31977-021	Complete Gear Motc As sembly

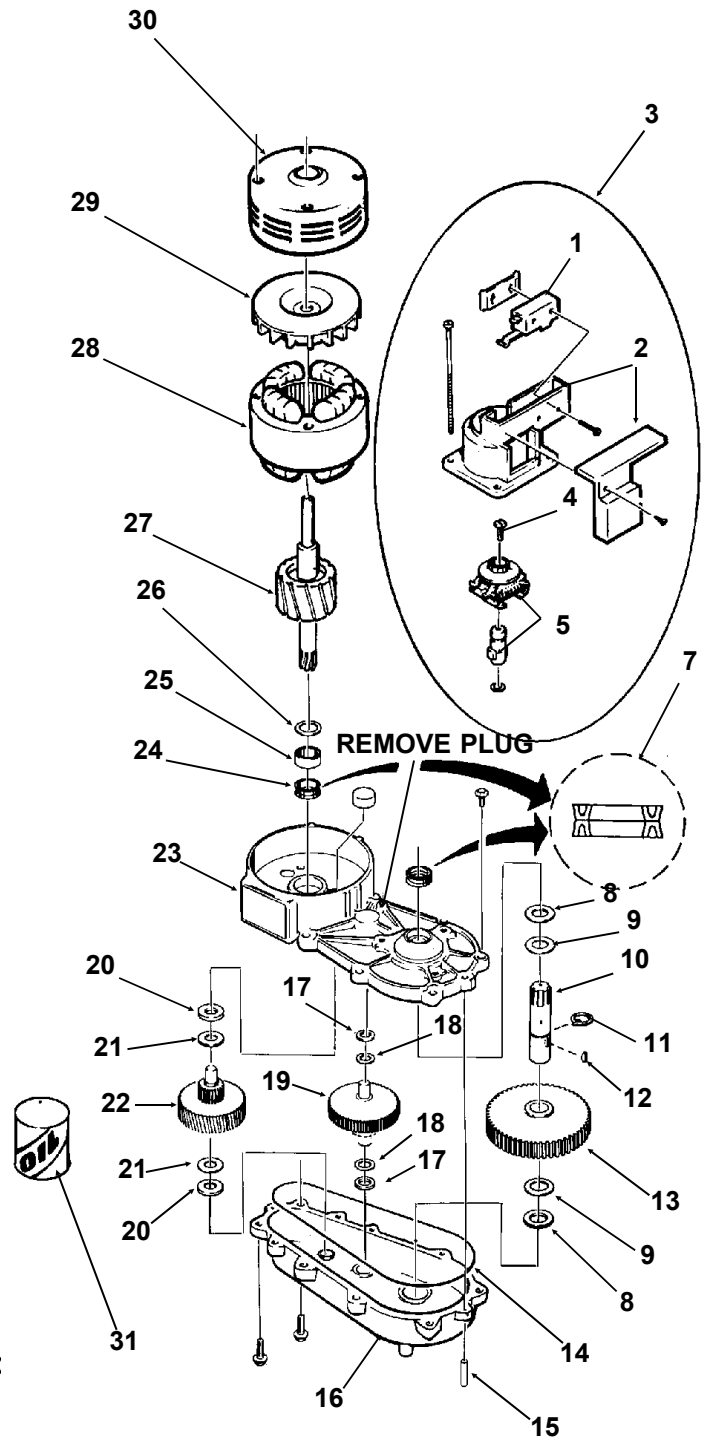

# MF400 SERVICE PARTS

## Control Box

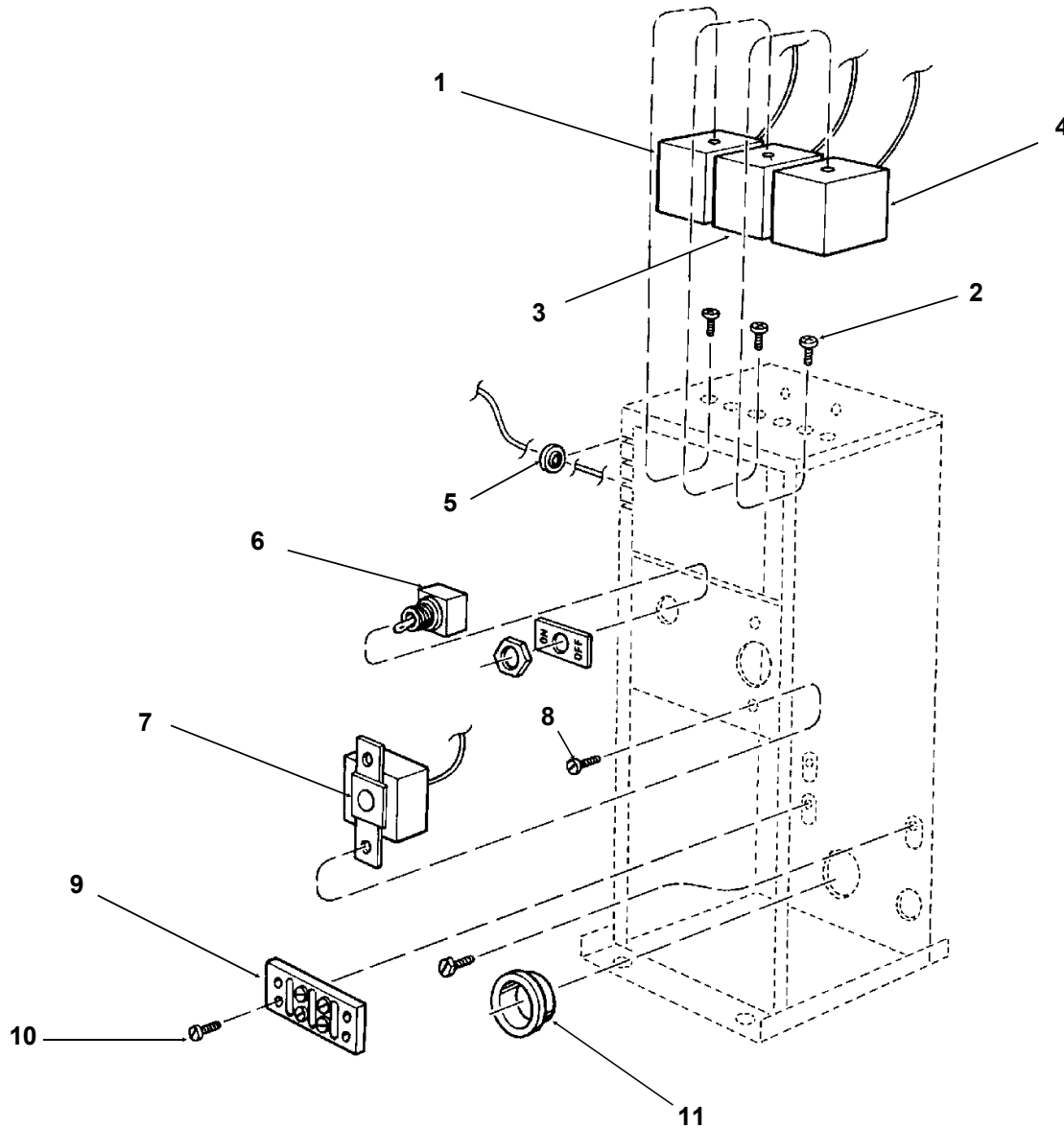

### CONTROL BOX

ITEM NUMBER	PART NUMBER	DESCRIPTION
1.	11-0420-01	Low pressure control
2.	03-1403-02	Mounting Screw
3.	11-0388-02	High pressure control, (w.c.)
4.	11-0402-01	Auger Delay Control
5.	13-0557-00	Grommet
6.	12-0426-01	Toggle switch
7.	11-0354-00	Bin Thermostat
8.	03-1403-17	Mounting screw
9.	12-0813-04	Terminal board
10.	03-1403-21	Mounting screw
11.	12-1213-12	Snap Bushing

# MF400 WIRING DIAGRAM Air Cooled

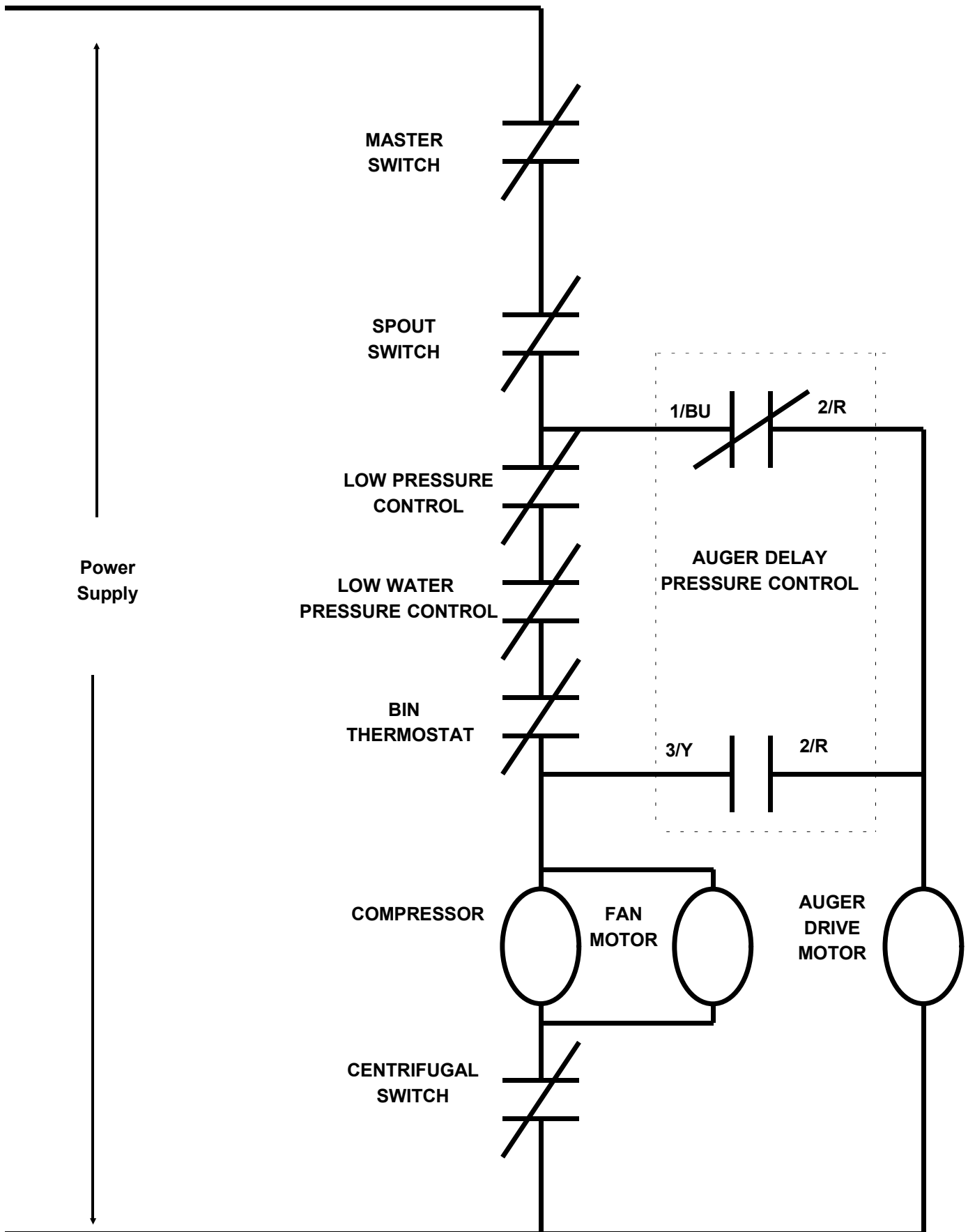

# MF400 WIRING DIAGRAM Air Cooled

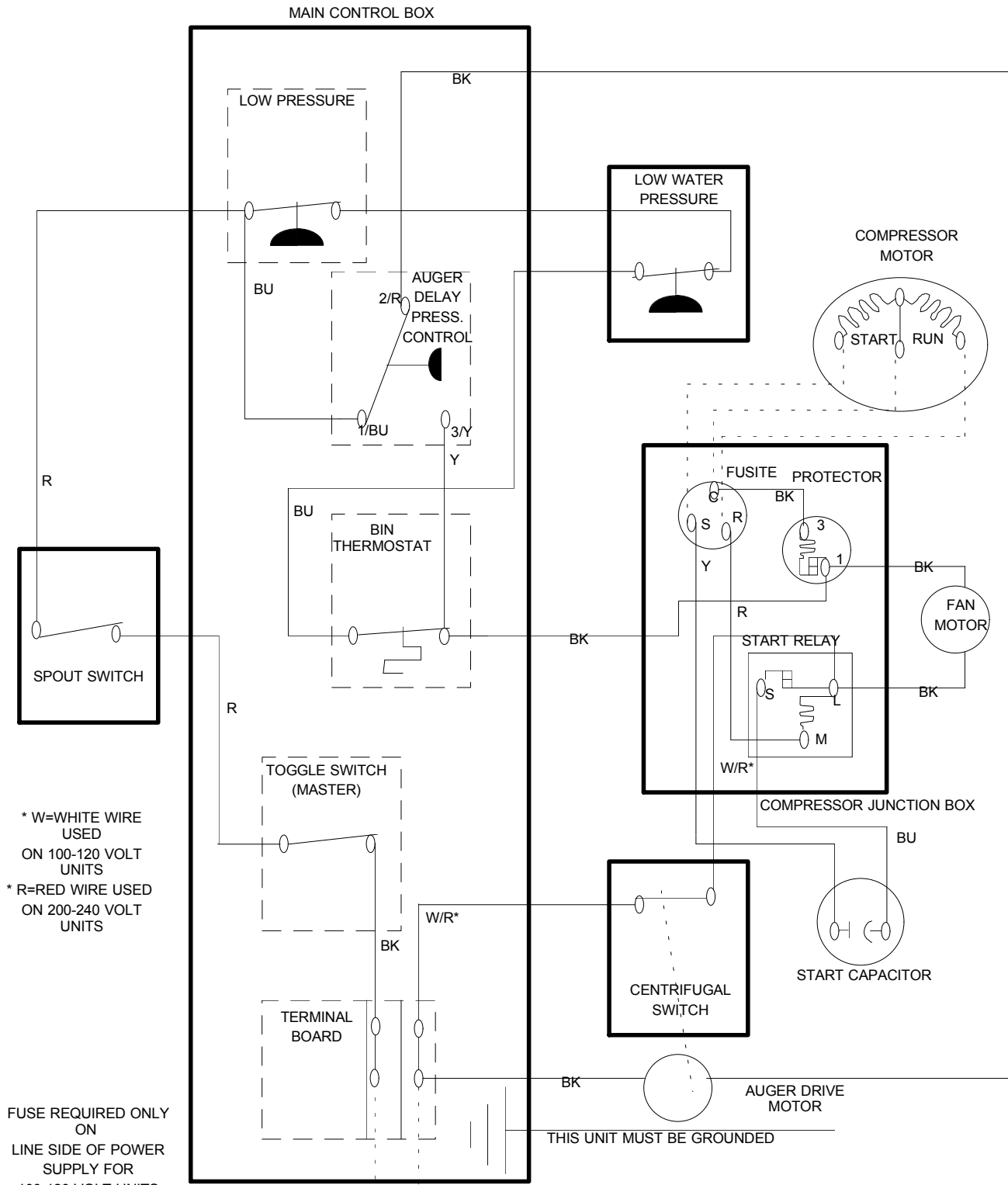

\* W=WHITE WIRE USED ON 100-120 VOLT UNITS  
 \* R=RED WIRE USED ON 200-240 VOLT UNITS

FUSE REQUIRED ONLY ON LINE SIDE OF POWER SUPPLY FOR 100-120 VOLT UNITS

POWER SUPPLY SEE NAMEPLATE FOR PROPER VOLTAGE REQUIREMENTS AND MAXIMUM FUSE SIZE

FUSES REQUIRED ON BOTH SIDES OF POWER SUPPLY FOR 200-240 VOLT UNITS

ALL CONTROL SHOWN IN THE NORMAL ICE MAKING MODE

# MF400 WIRING DIAGRAM Water Cooled

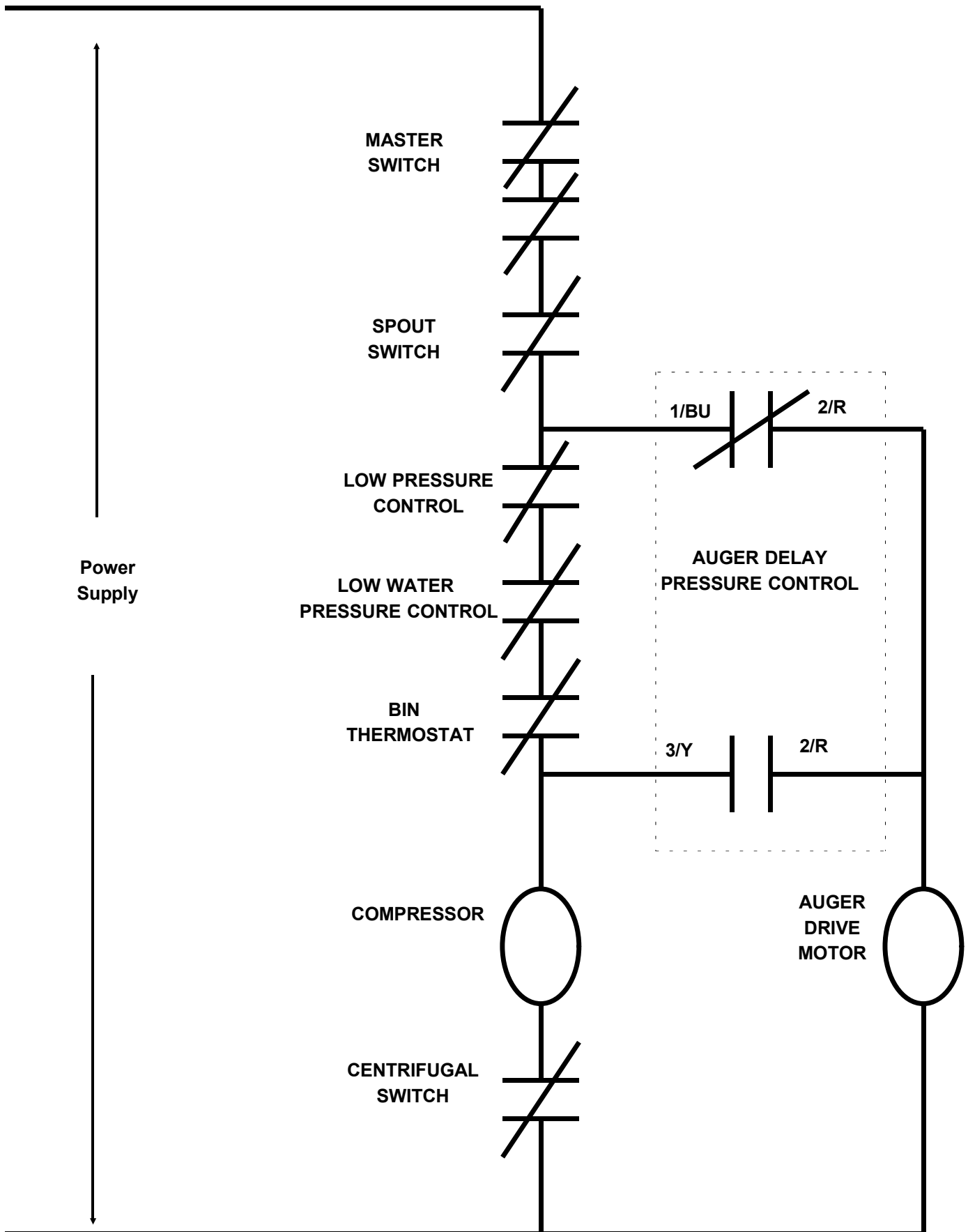

# MF400 WIRING DIAGRAM Water Cooled

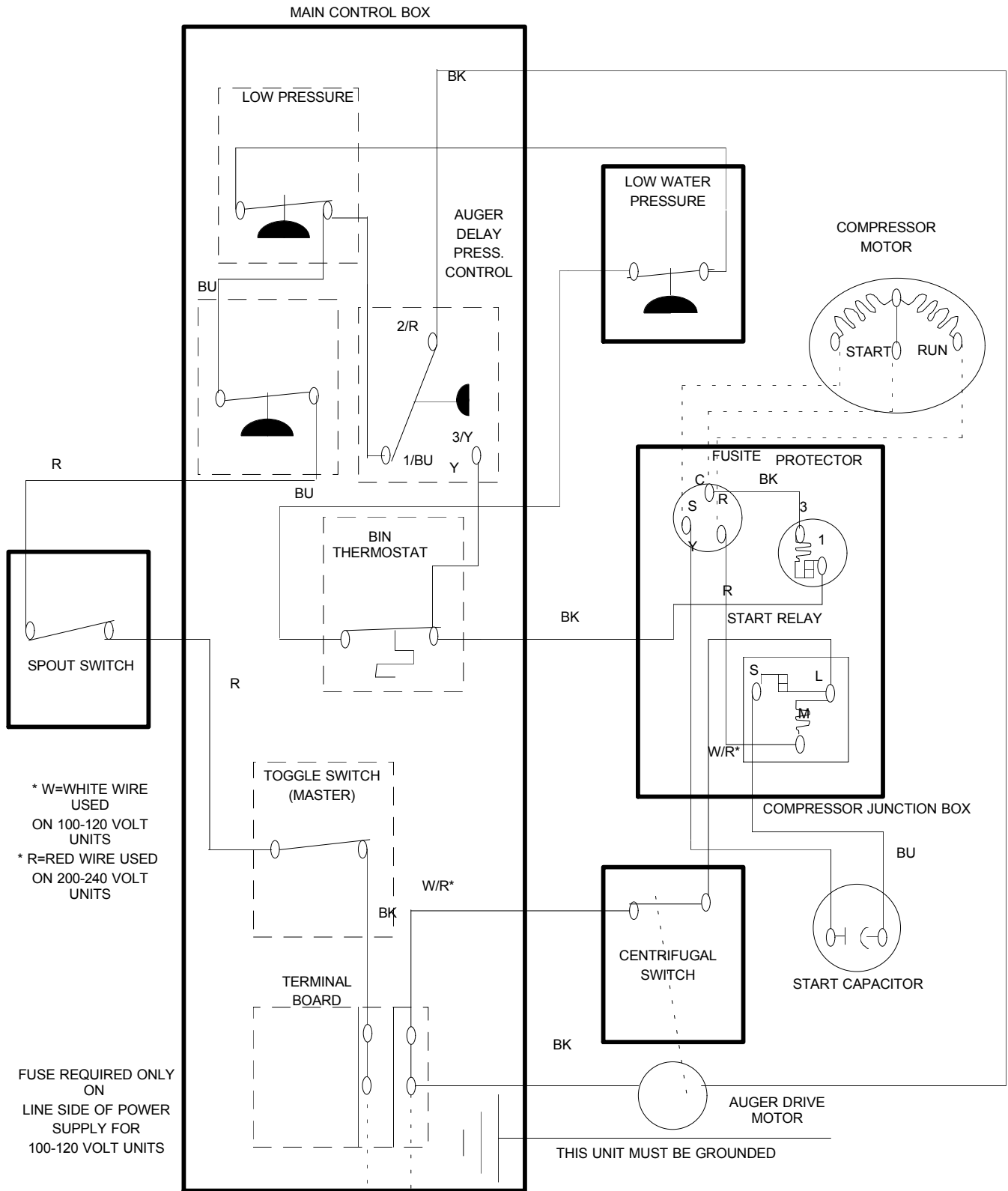

\* W=WHITE WIRE USED ON 100-120 VOLT UNITS  
 \* R=RED WIRE USED ON 200-240 VOLT UNITS

FUSE REQUIRED ONLY ON LINE SIDE OF POWER SUPPLY FOR 100-120 VOLT UNITS

POWER SUPPLY SEE NAMEPLATE FOR PROPER VOLTAGE REQUIREMENTS AND MAXIMUM FUSE SIZE

FUSES REQUIRED ON BOTH SIDES OF POWER SUPPLY FOR 200-240 VOLT UNITS

ALL CONTROL SHOWN IN THE NORMAL ICE MAKING MODE

THIS UNIT MUST BE GROUNDED