

NME954 & FME1204 SERVICE PARTS

This parts list contains the service parts and wiring diagrams for this model. Check the model number in question to be sure that it is applicable to this parts list.

Note that these machines have been manufactured in both 50 and 60 cycle. 60 Hz model numbers end in -3 or -32. 50 Hz model numbers end in -6.

Another change was to the water cooled condensers. Model numbers ending in A have a different water cooled condenser than the current model.

TABLE OF CONTENTS

Cabinet	2
Air Cooled Refrigeration	3
Water Cooled Refrigeration	4
Water System	5
Gearmotor	6
NME Evaporator	7
FME Evaporator	8
Control Box	9
Wiring Diagrams	10

NME954 & FME1204 SERVICE PARTS

Cabinet Assembly

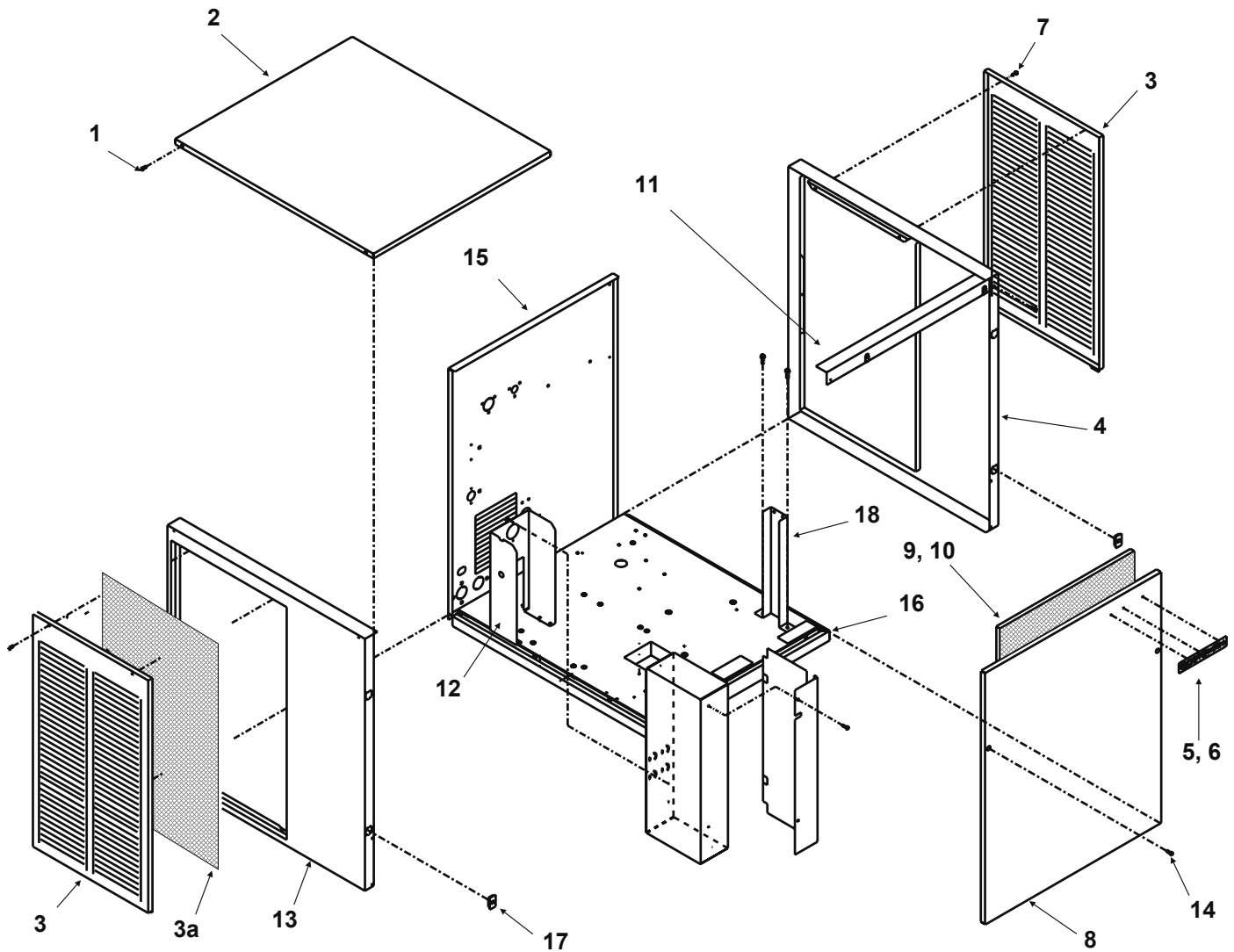

ITEM NUMBER	PART NUMBER	DESCRIPTION	ITEM NUMBER	PART NUMBER	DESCRIPTION
1	03-1531-01	Screw	9	02-2976-01	Filter Assembly for louvered front panel
2	A33256-002	Top Panel, S.S.	10	03-1660-01	Filter clip
3	A34038-002	Service Panel, non-louvered	11	A34348-001	Ft. brace
	A33946-002	Service panel, louvered	12	A34039-001	Control Box Support
3a	A32975-001	Air filter media, for louvered service panel. Same on other side	13	A32435-002	Left Side Panel, S.S.
4	A33292-002	Right Side Panel, S.S.	14	03-1419-22	Screw
5	03-0271-00	Speed Clip	15	Water Cooled only:	
6	15-0808-03	Emblem, grey		A35924-002	Rear panel, stainless
7	03-1404-12	Screw	16.	A35890-001	Base
8	A33255-002	Front Panel, louvered	17	02-0836-00	Catch
	A39048-001	Front panel, non-louvered		15-0411-00	Strike (on front panel)
			18	A36078-001	Reservoir bracket

NME954 & FME1204 SERVICE PARTS

Air Cooled Refrigeration

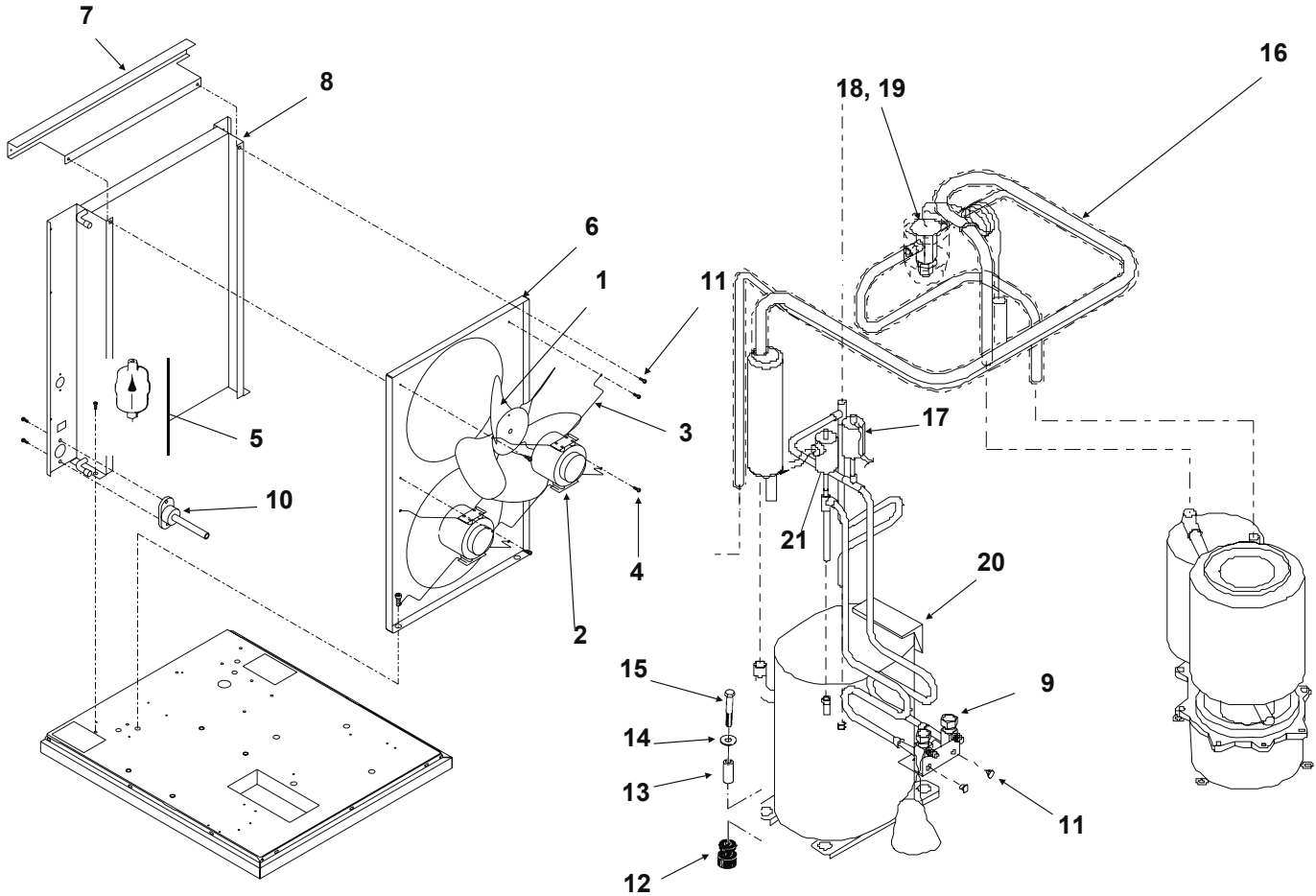

ITEM NUMBER	PART NUMBER	DESCRIPTION	ITEM NUMBER	PART NUMBER	DESCRIPTION
1	18-3815-01	Fan Blade	14	03-1407-07	Washer
2	12-1576-02	Fan Motor	15	03-1405-20	Cap Screw
3	02-2378-01	Fan Bracket	16	A36496-001	Suction Line
4	03-1404-12	Screw	17	11-0501-22	Hi Pressure Cut Out
5	02-3319-02	Dryer	18	A32961-020	Insulation Kit (3 piece)
6	A33231-001	Fan Shroud	19	11-0488-21	Thermo Expansion Valve
7	A35582-002	Fan shroud cover, stainless	20	18-8768-22	Compressor 208-230/60/1 Overload for above is internal
8	18-8717-01	Condenser		18-8768-24	Compressor 200-230/60/3 Overload for above is internal
9	16-0832-20	Access valve		18-8772-26	Compressor 220-240/50/1
9a	16-0832-02	Stem cap		18-8772-21	Overload for above
9b	16-0832-03	Core cap			
10	A34045-001	Drain casting	21	11-0502-21	Low pressure cut out switch
11	03-1645-01	Screw			
12	18-2200-28	Grommet			
13	18-2300-27	Sleeve			

NME954 & FME1204 SERVICE PARTS

Water Cooled Refrigeration

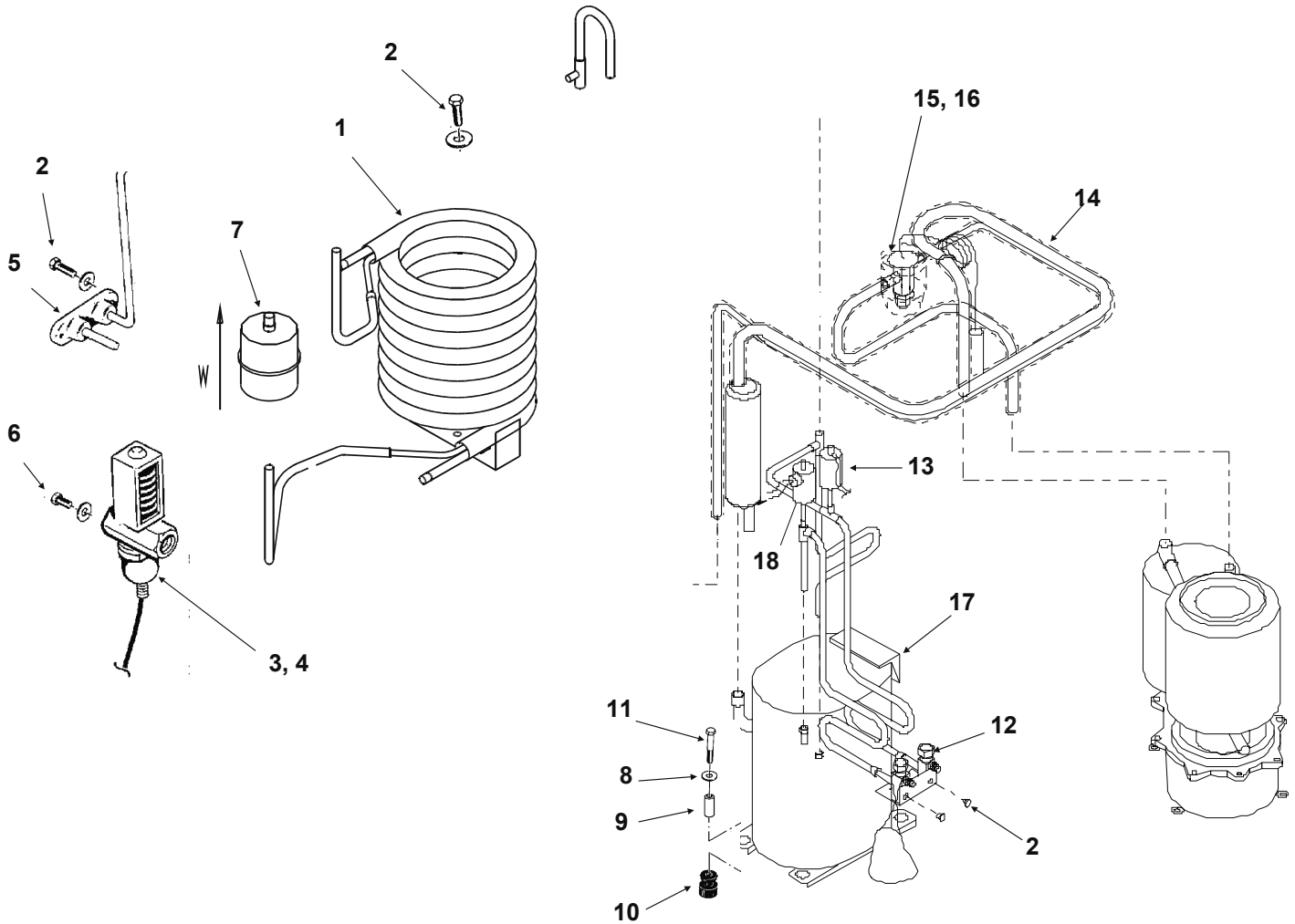

ITEM NUMBER	PART NUMBER	DESCRIPTION			
1	18-8718-25	Condenser for A series			
	18-8873-21	Condenser for B series			
2	03-1645-01	Screw	12	16-0832-20	Access Valve Complete
3	11-0478-.01	Water Reg. Valve	12a	16-0832-02	Stem cap
4	16-0401-02	Elbow (not shown)	12b	16-0832-03	Core cap
5	A34044-001	Drain Assembly	13	11-0501-22	Hi Pressure Cut Out
6	03-1403-14	Screw	14	A36496-001	Suction Line
7	02-3319-02	Dryer	15	A32961-020	Insulation Kit (3 piece)
8	03-1407-07	Washer	16	11-0488-21	Thermo Expansion Valve
9	18-2200-27	Sleeve	17	18-8768-22	Compressor 208-230/60/1
10	18-2200-28	Grommet			Overload for above is internal
11	03-1405-20	Screw			18-8768-24 Compressor 200-230/60/3
					Overload for above is internal
					18-8772-26 Compressor 220-240/50/1
					18-8772-21 Overload for above
			18	11-0502-21	Low pressure cut out switch

NME954 & FME1204 SERVICE PARTS

Water System

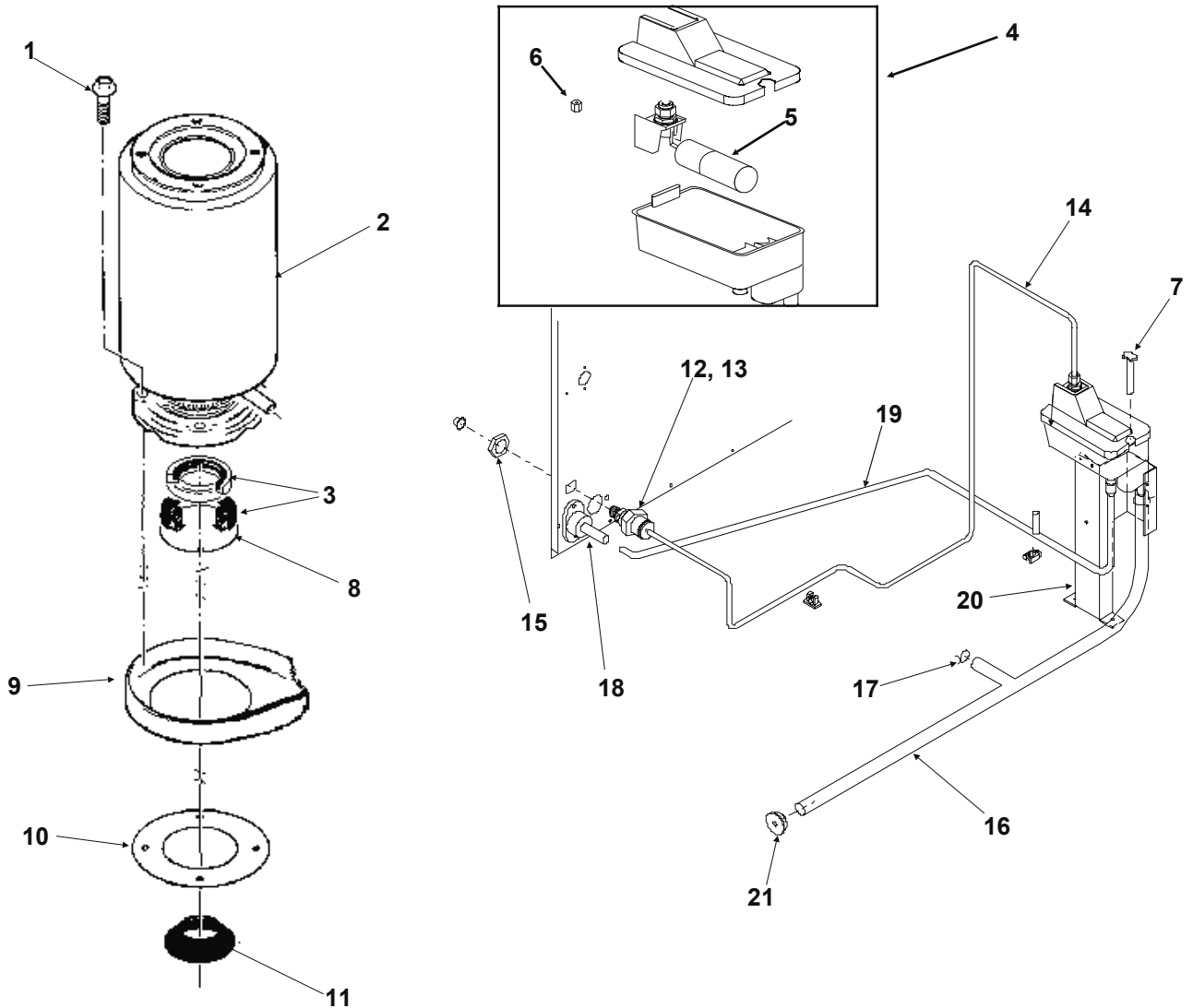

ITEM NUMBER	PART NUMBER	DESCRIPTION
1	03-1420-03	Cap Screw
2	A32890-020	Evaporator
3	02-0929-23	Water Seal
4	02-3266-20	Reservoir & valve
5	02-3266-21	Float valve
6	02-3266-03	Plunger/seat
7	12-2760-21	Water Level Sensor
8	A32777-001	Retaining Ring for Seal
9	02-3837-01	Drip Pan
10	13-0704-00	Gasket
11	13-0868-01	Water Shed
12	16-1039-01	Male connector
13	16-0835-01	Water fitting
14	13-0895-01	Inlet tubing, 4 ft req.

ITEM NUMBER	PART NUMBER	DESCRIPTION
15	03-1394-01	Pal nut
16	A36154-001	Evap. water inlet tube
17	02-1338-00	Hose clamp
18	02-3692-02	Drain fitting
19	02-3826-01	Res. overflow hose
20	A36078-002	Reservoir bracket
21	13-0840-01	Rubber cap

NME954 & FME1204 SERVICE PARTS

Gearmotor

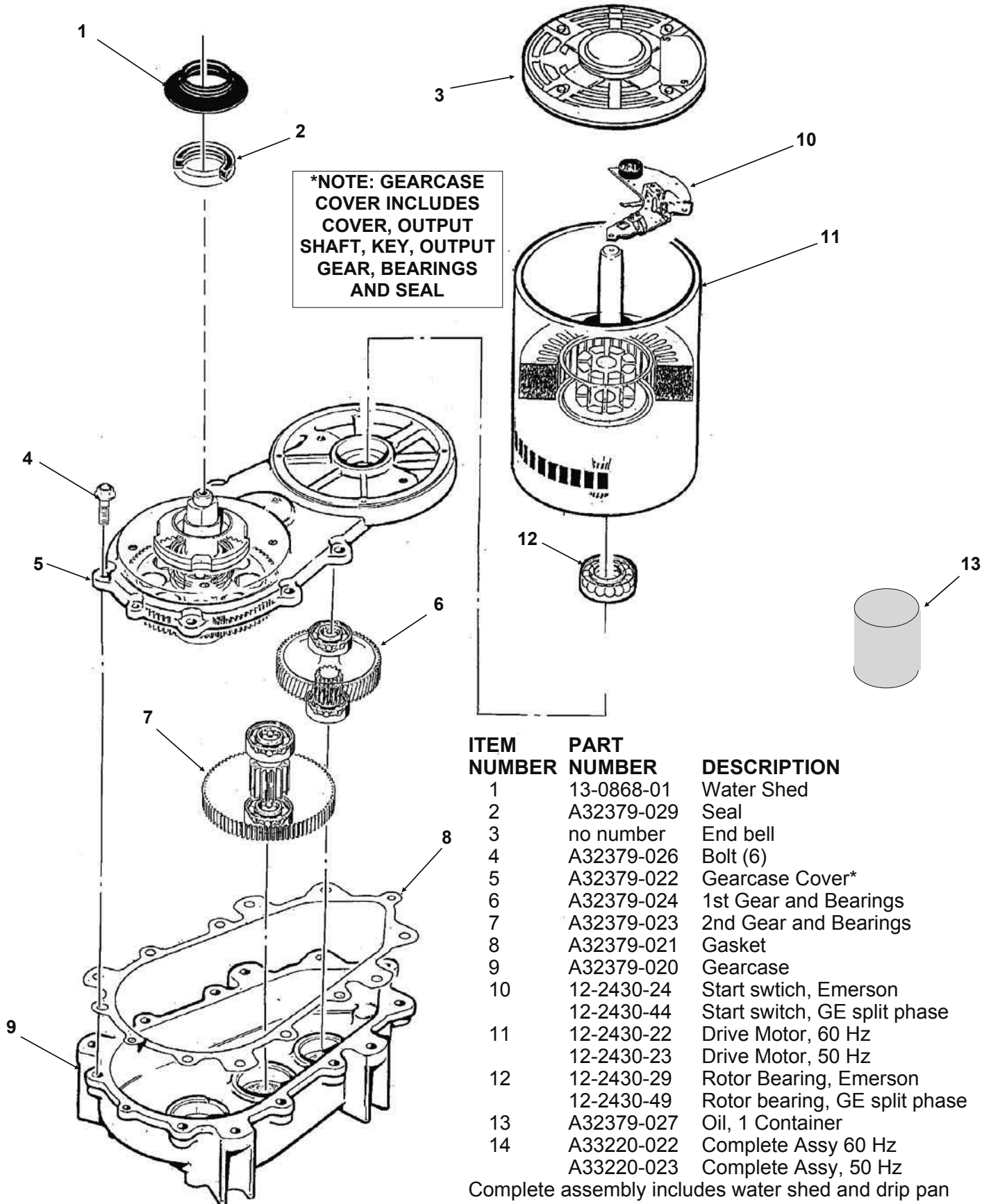

***NOTE: GEARCASE COVER INCLUDES COVER, OUTPUT SHAFT, KEY, OUTPUT GEAR, BEARINGS AND SEAL**

ITEM NUMBER	PART NUMBER	DESCRIPTION
1	13-0868-01	Water Shed
2	A32379-029	Seal
3	no number	End bell
4	A32379-026	Bolt (6)
5	A32379-022	Gearcase Cover*
6	A32379-024	1st Gear and Bearings
7	A32379-023	2nd Gear and Bearings
8	A32379-021	Gasket
9	A32379-020	Gearcase
10	12-2430-24	Start switch, Emerson
	12-2430-44	Start switch, GE split phase
11	12-2430-22	Drive Motor, 60 Hz
	12-2430-23	Drive Motor, 50 Hz
12	12-2430-29	Rotor Bearing, Emerson
	12-2430-49	Rotor bearing, GE split phase
13	A32379-027	Oil, 1 Container
14	A33220-022	Complete Assy 60 Hz
	A33220-023	Complete Assy, 50 Hz

Complete assembly includes water shed and drip pan gasket.

15 A33220-030 Gear and case kit, no motor

NME954 & FME1204 SERVICE PARTS

NME Evaporator

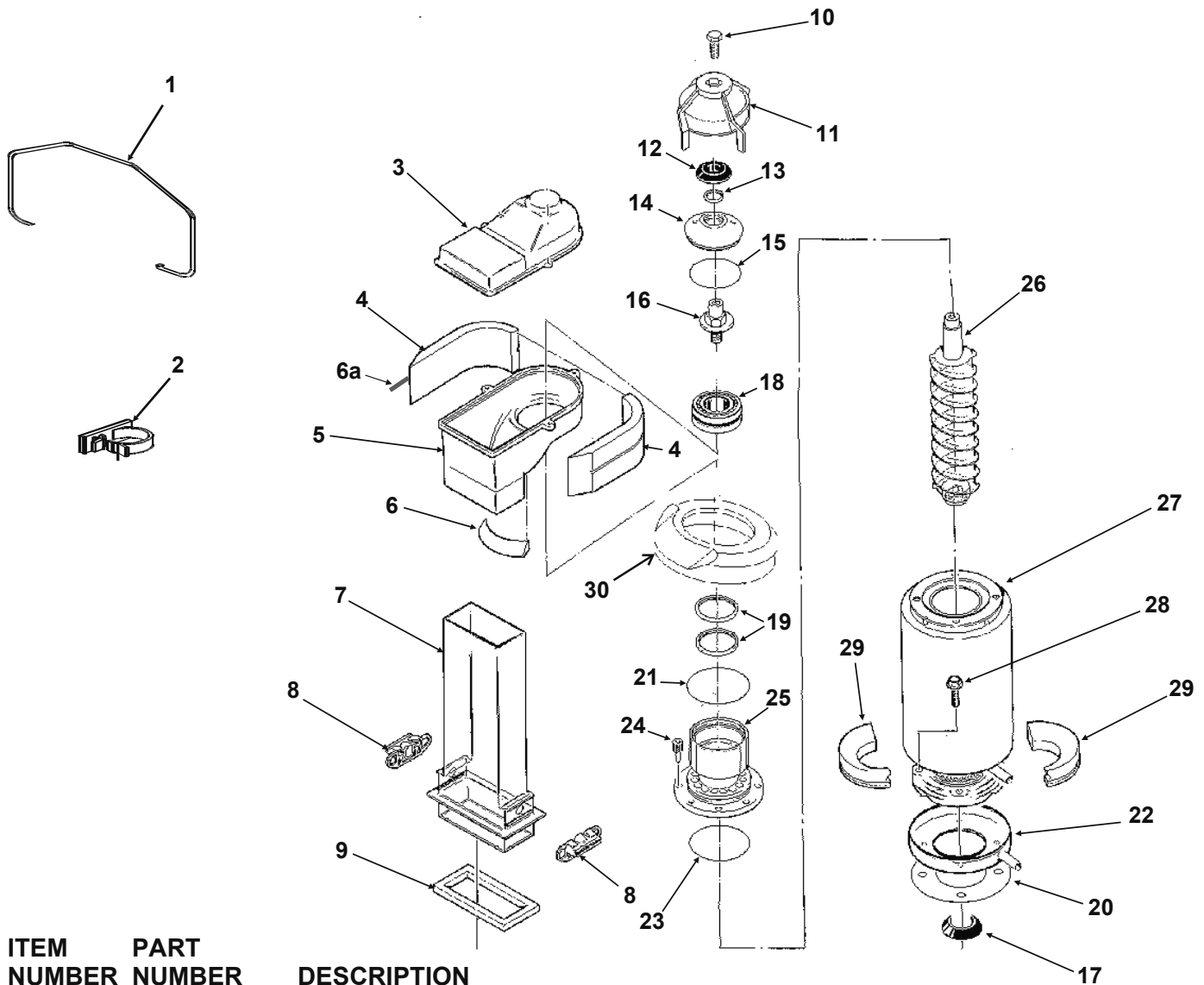

ITEM NUMBER	PART NUMBER	DESCRIPTION
1.	A34969-001	Bail clip
2.	02-3268-01	Drain tube holder
3.	02-2930-04	Ice Chute Cover
4.	A32963-001*	Insulation Top (half)
5.	02-3841-01*	Ice Chute Body, includes insulation, repl item 4
6.	A33102-001*	Insulation Collar Inside
6a	A35419-020*	Strap kit
7.	02-2929-04	Ice Chute Lower
8.	A37708-021	Bin Controls Kit. (set of 2)
9.	A32930-001	Chute Gasket
10.	03-1405-52	Hex Cap Screw
11.	02-3001-01	Ice Sweep
12.	13-0871-01	Water Shed
13.	02-2978-01	Lip Seal
14.	02-3128-20	Breaker Cover
15.	13-0617-52	O-Ring
16.	08-0660-01	Auger Stud & washer
17.	13-0868-01	Water Shed
18.	A34559-020	Bearing
19.	02-2977-01	Lip Seal
20.	13-0704-00	Drip Pan Gasket
21.	13-0617-54	O-Ring
22.	02-3837-01	Drip Pan
23.	13-0617-45	O-Ring
24.	03-1544-08	Soc. Head Screw
25.	A32900-020	Breaker (includes 18 & 19)
26.	A38071-022	Auger
27.	A32890-020	Evaporator
28.	03-1420-03	Cap Screw
29.	A32962-001	Insulation Bot. (half)
30.	13-0929-02	Insulation donut*

* Insulation changed Oct. 2000. Item 4, 6 and 6a no longer used. Item 5 changed. Item 30 added.

NME954 & FME1204 SERVICE PARTS

FME Evaporator

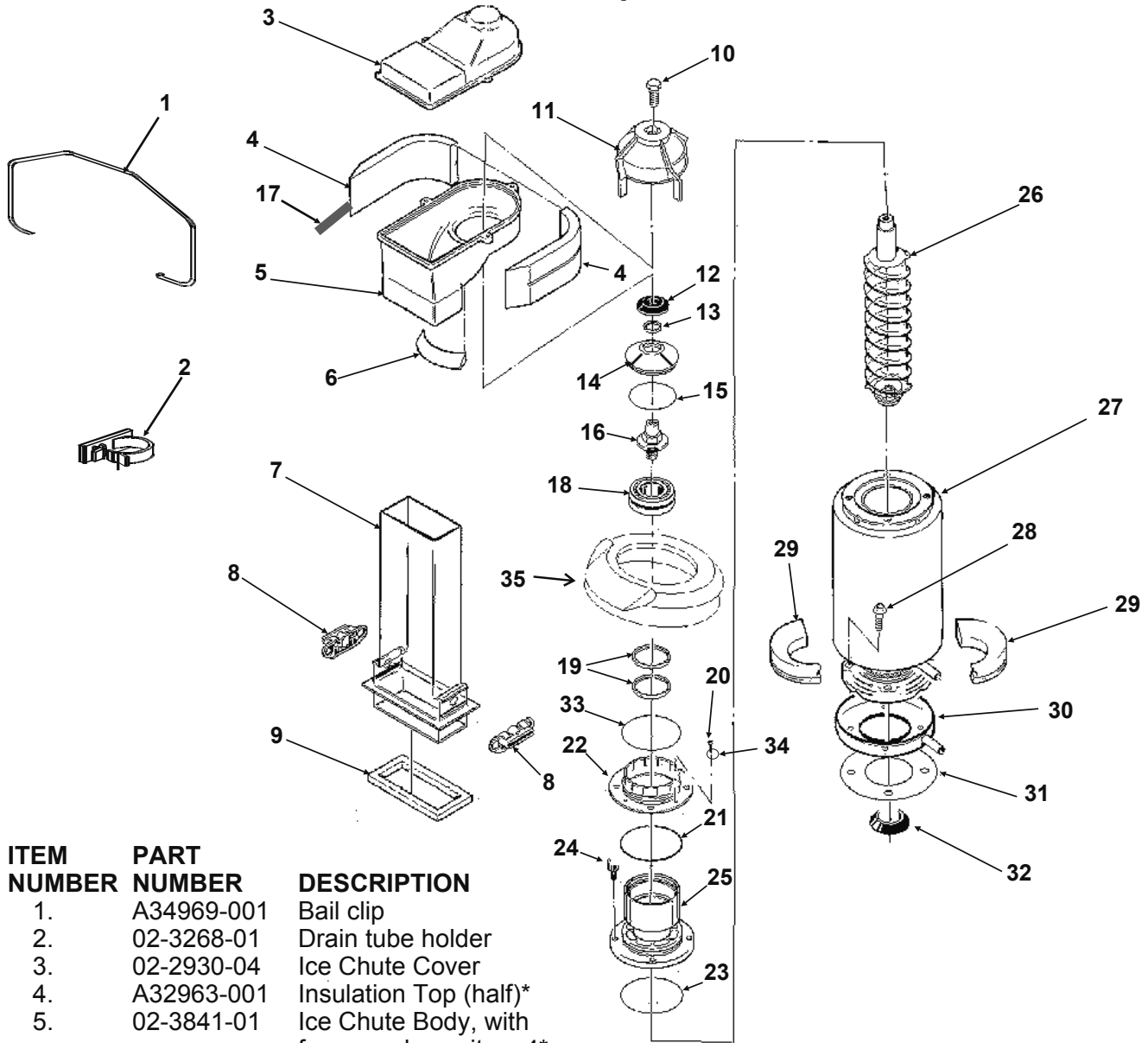

ITEM NUMBER	PART NUMBER	DESCRIPTION
1.	A34969-001	Bail clip
2.	02-3268-01	Drain tube holder
3.	02-2930-04	Ice Chute Cover
4.	A32963-001	Insulation Top (half)*
5.	02-3841-01	Ice Chute Body, with foam, replaces item 4*
6.	A33102-001	Insulation Collar Inside*
7.	02-2929-04	Ice Chute Lower
8.	A37708-021	Bin Controls Assy. (set of 2)
9.	A32930-001	Chute Gasket
10.	03-1405-52	Hex Cap Screw
11.	02-3001-01	Ice Sweep
12.	13-0871-01	Water Shed
13.	02-2978-01	Lip Seal
14.	02-3128-01	Breaker Cover
15.	13-0617-54	O-Ring
16.	08-0660-20	Auger Stud, thrust Washer
17.	A35419-020	Strap kit*
18.	A34559-020	Bearing
19.	02-2977-01	Lip Seal
20.	03-1405-27	Screw
21.	13-0617-52	O-Ring
22.	02-2916-01	Slotted Collar
23.	13-0617-45	O-Ring
24.	03-1544-08	Soc. Head Screw
25.	A34505-020	Breaker (Divider) (includes 18 & 19)
26.	A38071-022	Auger
27.	A32890-020	Evaporator
28.	03-1420-03	Cap Screw
29.	A32962-001	Insulation Bot. (half)
30.	02-3837-01	Drip Pan
31.	13-0704-00	Drip Pan Gasket
32.	13-0868-01	Water Shed
33.	13-0617-49	O-Ring
34.	03-1408-36	Washer
35.	13-0929-01	Insulation donut*

* Insulation changed Oct 2000. Items 4, 6 and 17 no longer used. Item 5 changed. Item 35 added.

NME954 & FME1204 SERVICE PARTS

Control Box

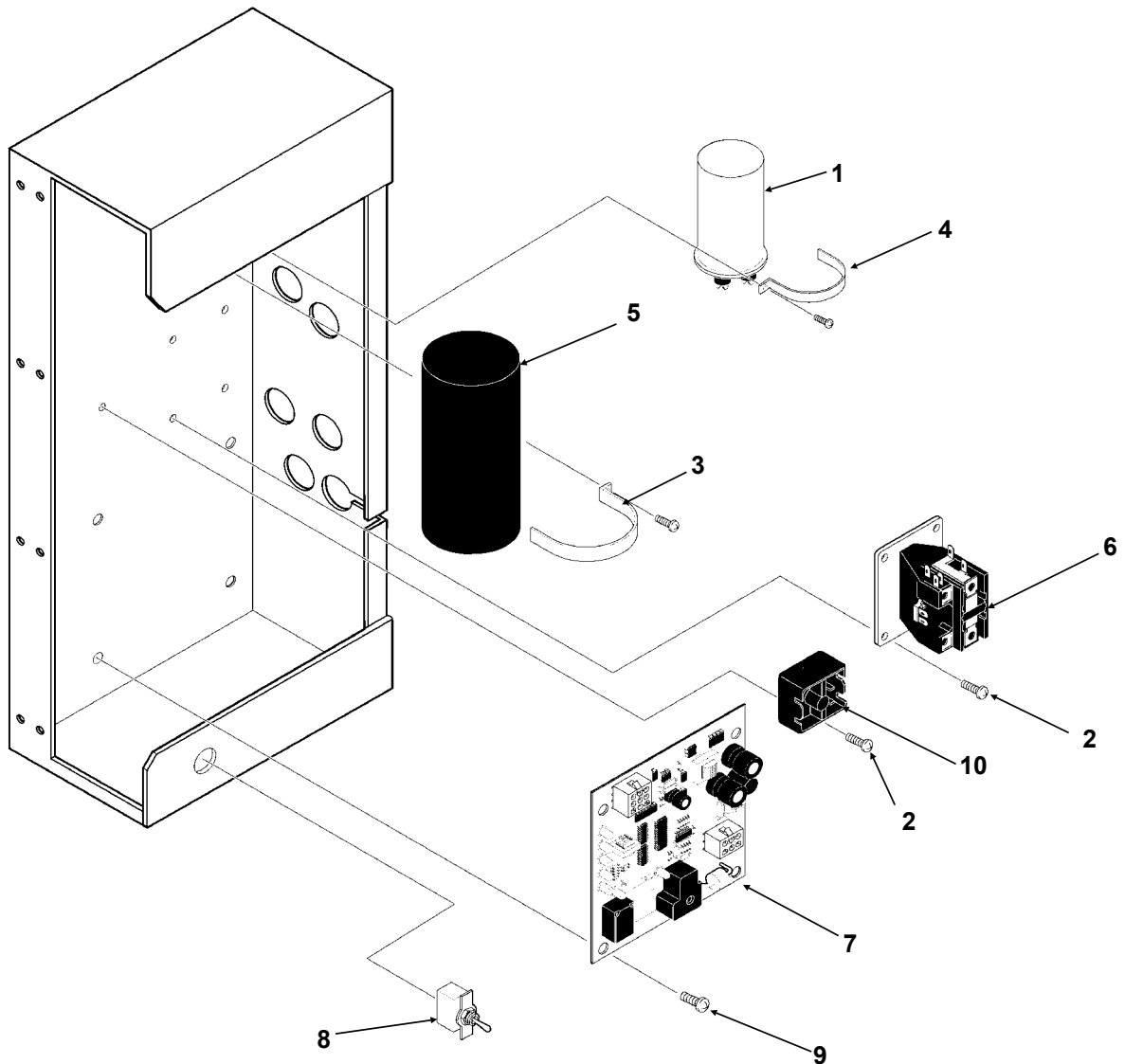

ITEM NUMBER	PART NUMBER	DESCRIPTION
1	18-1901-54	Start Capacitor, 60 Hz
	18-1901-53	Start Capacitor, 50 Hz
2.	03-1638-03	Screw
3.	A35971-002	Run Cap Bracket
4.	A35971-001	Start cap bracket
5.	18-1902-45	Run capacitor, 60 Hz
	18-1902-53	Run capacitor, 50 Hz
6.	12-2469-02	Single Phase Contactor
	12-2533-02	Three phase contactor

ITEM NUMBER	PART NUMBER	DESCRIPTION
7	12-2835-21	Circuit Board
8.	12-0426-02	Mode Switch
NME-6 or FME-6 only: (50 Hz)		
	12-2637-01	Mode Switch
9.	12-2350-01	Standoff
10	18-1903-33	Potential Relay, 60 Hz
	18-1903-54	Potential relay, 50 Hz

Note: Hz means Cycles, 50 Hz is 50 cycle, the model number ends in a -6 for 50 Hz models.

NOT ILLUSTRATED		
11.	A37861-001	Control Box Cover

NME954 & FME1204 SERVICE PARTS

AIR AND WATER COOLED, 208-230/60/1

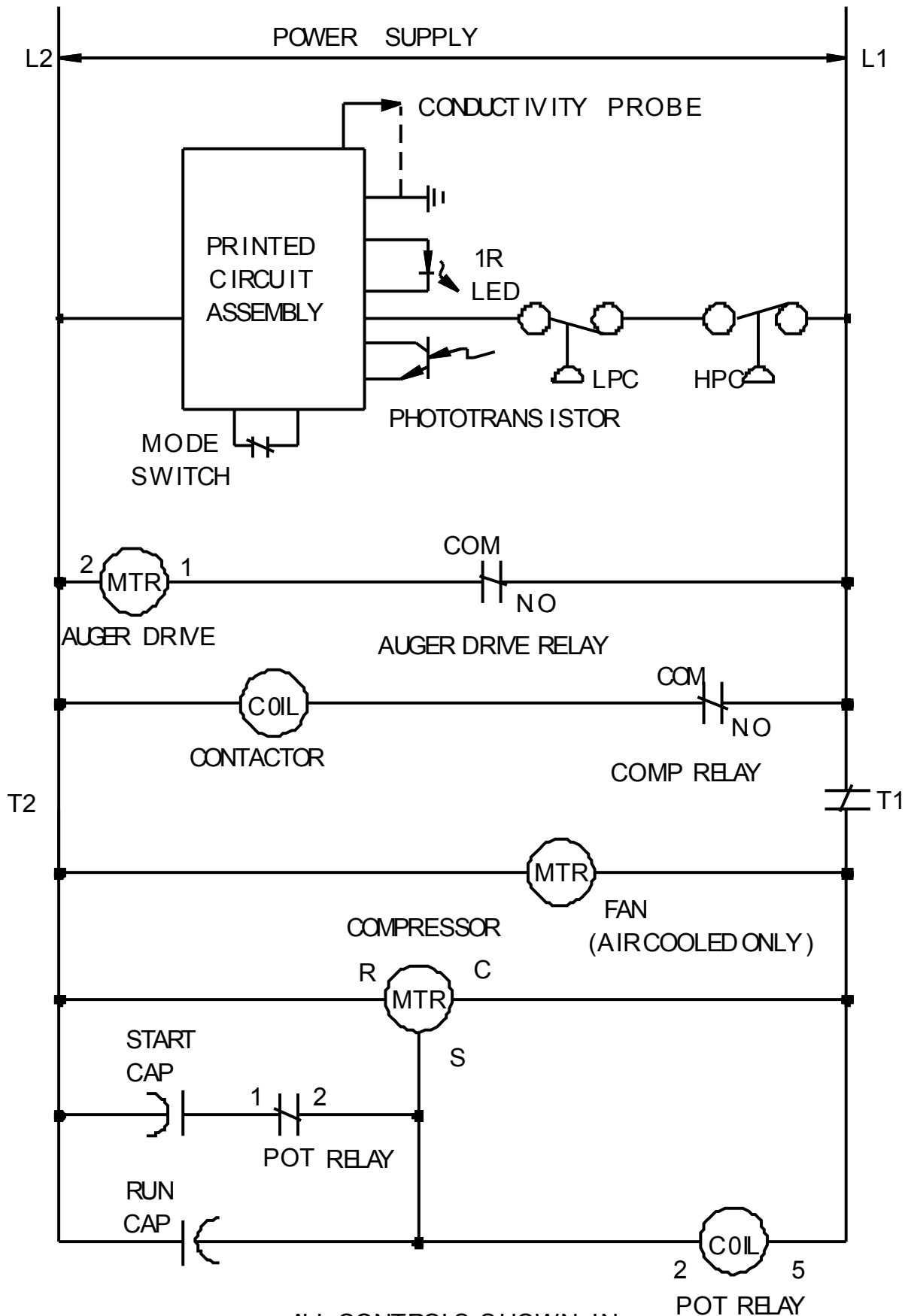

ALL CONTROLS SHOWN IN
ICE MAKING MODE

January 2000

Page 10

NME954 & FME1204 SERVICE PARTS

AIR AND WATER COOLED, 208-230/60/1

7-2678-01

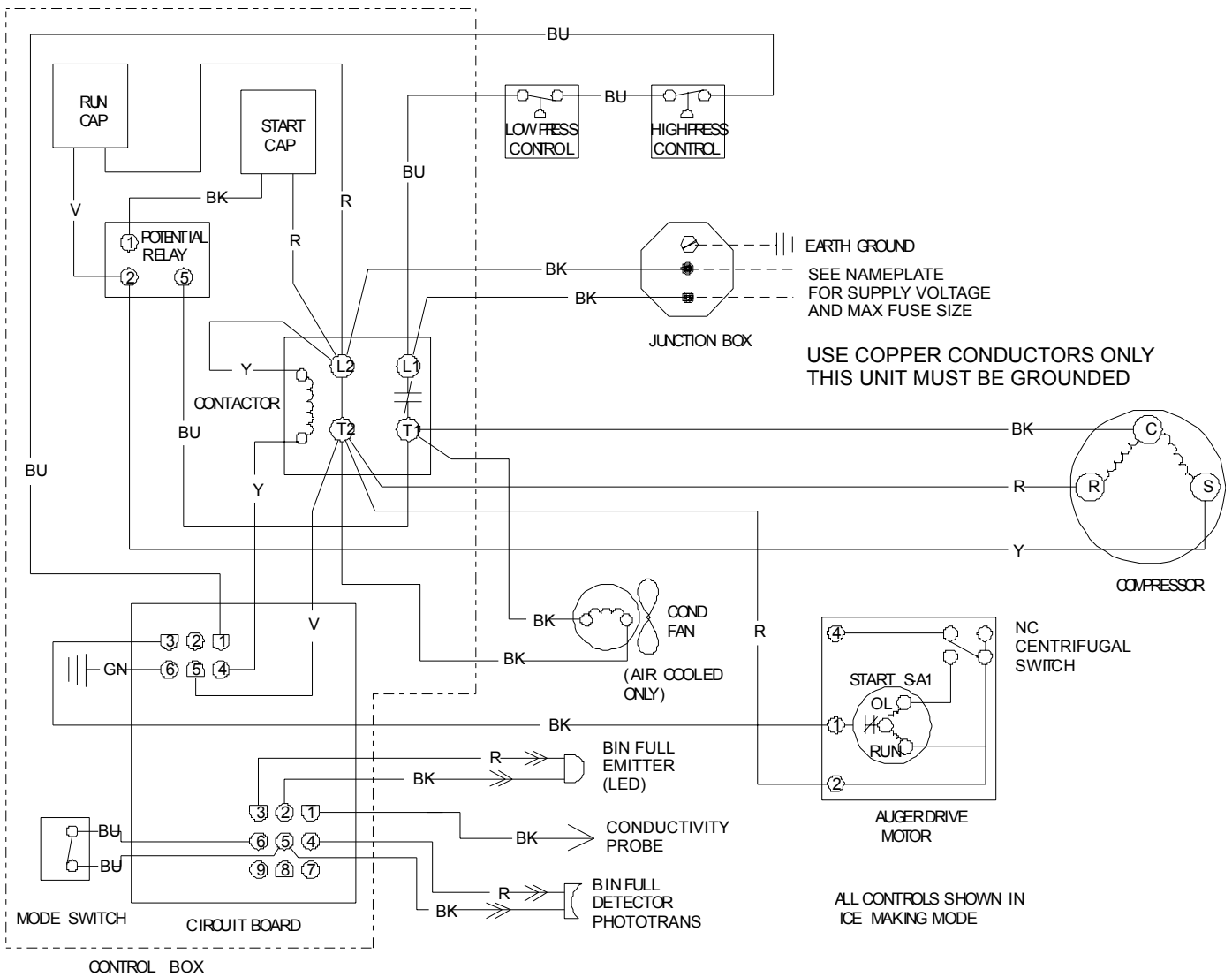

NME954 & FME1204 SERVICE PARTS

AIR AND WATER COOLED, 208-230/60/3

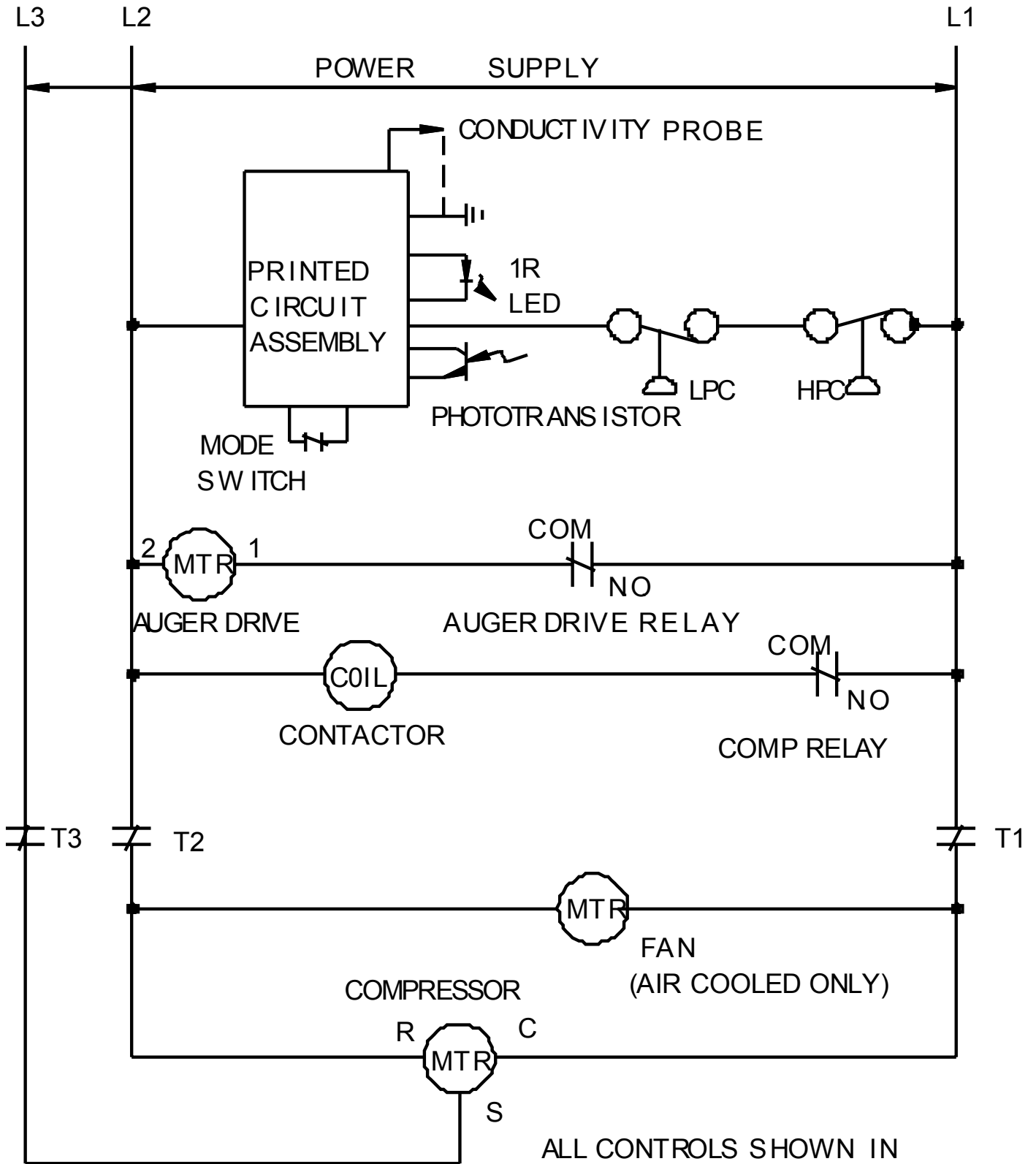

ALL CONTROLS SHOWN IN
ICE MAKING MODE

NME954 & FME1204 SERVICE PARTS

AIR AND WATER COOLED, 208-230/60/3

7-2680-01

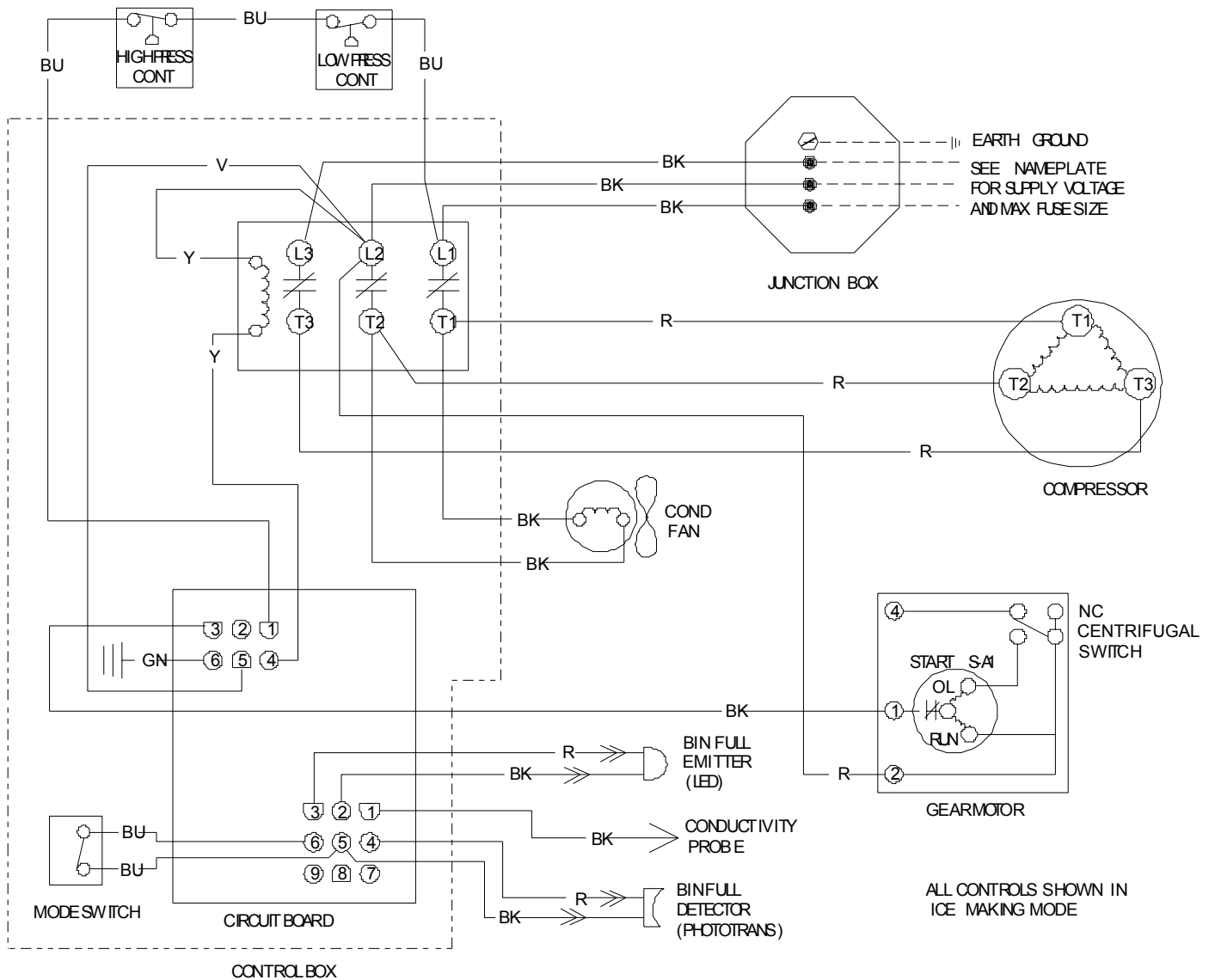

NME954 & FME1204 SERVICE PARTS

NME954 or FME1204 -6

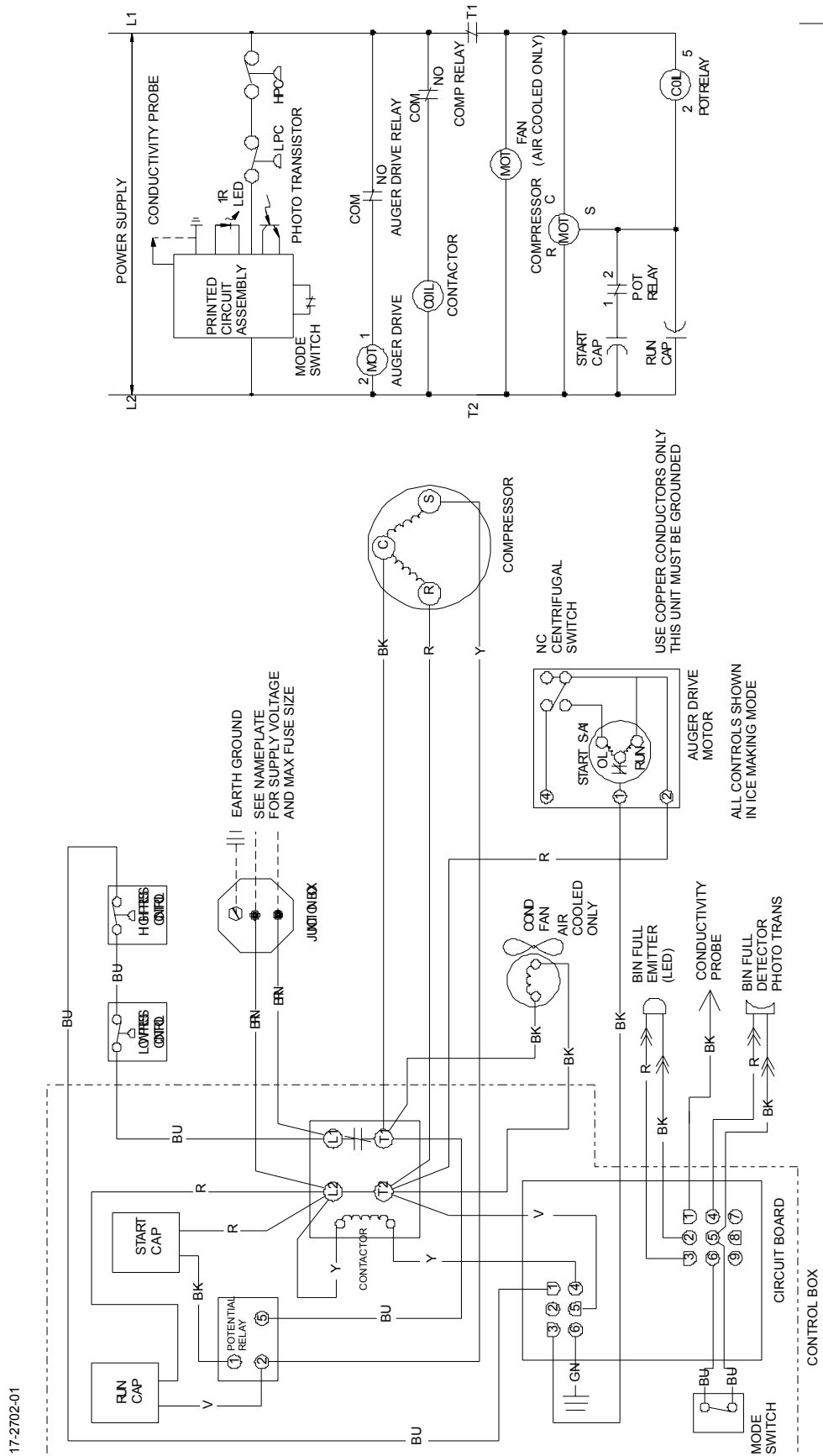

17-2702-01