

CME506R, 656R, 806R: AutoIQ Cubers

Introduction:

This product manual contains the information needed for the setup, installation, initial start up, sanitation and maintenance of this ice machine. Keep it for future reference.

There are 3 models covered in this manual:

- CME506R, a 115 volt, dual evaporator machine
- CME656R and CME806R, 230 volt, dual evaporator machines

Be certain that the information applies to the model in question. If no model is listed, the information applies to all models, including A and D series.

This manual is organized in the same way as the expected use of the machine, it begins with specifications, goes thru unpacking and setup, shows where everything is; continues with initial start up, then describes how it works. After that is the sanitation section, followed by service diagnosis and repair.

Table Of Contents

Specifications:	page 2	Additional Maintenance	page 23
Pre-Installation	page 3	Additional Maintenance: Water Distributors	page 24
Location:	page 4	Additional Maintenance: Inlet Water Valve Screen	page 25
Stacking:	page 5	Additional Maintenance: Bin Controls, Condenser	page 26
Remote Condenser Location	page 6	Service Diagnosis: Controller Diagnostic Light Analysis	page 27
For The Installer: Remote Condenser	page 7	Service Diagnosis	page 28
Coupling Instructions	page 8	Service Diagnosis: Components	page 29
Electrical:	page 9	Service Diagnosis	page 30
Electrical Connections: KCMR230 Fan Relay Kit (CME656R & CME806R only)	page 10	PTCR Diagnosis	page 31
Plumbing:	page 11	Operational Characteristics: CME506R	page 32
After Utility Connections:	page 12	Operational Characteristics: CME656R	page 33
Component Location and Function:	page 13	Operational Characteristics: CME806R	page 34
AutoIQ Controller:	page 14	Removal and Replacement	page 35
Initial Start Up:	page 15	Removal and Replacement	page 36
Adjustments:	page 16	Removal and Replacement: AutoIQ Controller	page 37
Adjustments:	page 17	Removal and Replacement: Water Level Sensor	page 38
How To Operate The AutoIQ Controller	page 18	Removal and Replacement:	page 39
How The Electronic Cuber Works	page 19	Access Valves:	page 40
Technicians Only: Freeze Cycle Operational Sequence	page 20	Before Calling for Service	page 41
Technicians Only: Harvest Cycle Operational Sequence	page 21		
Sanitation and Cleaning	page 22		

CME506R, 656R, 806R: AutoIQ Cubers

Specifications:

These ice machines are designed to be installed indoors, in a controlled environment. They can operate satisfactorily under a wide variety of conditions. However, Do NOT operate the machine where it has not been designed for. Do NOT operate the machine in temperatures it has not been designed for. Do NOT operate the machine above or below the voltage limits for the particular model. Do NOT operate the machine with too little or too much water pressure.

All models will fit a standard, 30" wide Scotsman Ice Storage Bin. Some examples are:

- BH550
- HTB555
- HTB350
- HTB500
- HTB250

CME506R Operational Limits

	Minimum	Maximum
Air Temperature	50°F.	100°F.
Water Temperature	40°F.	100°F.
Water Pressure	20 psi	80 psi
Voltage (60 Hz)	103	126
Voltage (50 Hz)	207	253

In addition, there may be other bins that can be used, check Scotsman's sales literature for application information.

Note: All of these models fill the bin very full, and only shut off when ice has filled the bin to the base of the ice machine.

Scotsman reserves the right to make design changes and/or improvements at any time. Specifications and designs are subject to change without notice.

Scotsman assumes no liability or responsibility of any kind for products manufactured by Scotsman that have been altered in any way, including the use of any parts and/or other components not specifically approved by Scotsman.

CME656R and CME806R Operational Limits

	Minimum	Maximum
Air Temperature*	50°F.	100°F.
Water Temperature	40°F.	100°F.
Water Pressure	20 psi	80 psi
Voltage (60 Hz)	198	253
Voltage (50 Hz)	207	253

BASIC INFORMATION

Model Number	Dimensions W x D x H (w/o bin)	Basic Electrical (volts/Hz/phase)	For Single Pass Condenser, use	For Dual Pass Condenser, use	Minimum Circuit Ampacity	Maximum Fuse Size
CME506RS-1E	30" x 24" x 27	115/60/1	ERC101-1A	n/a	20	20
CME506RS-6E	same	230/50/1	ERC151-32A	ERC302-32A		
CME656RS-32E	same	208-230/60/1	ERC201-32A	ERC402-32A	16.9	20
CME656RS-6E	same	230/50/1	ERC201-32A	ERC402-32A		
CME656RS-3E	same	208-230/60/3	ERC201-32A	ERC402-32A	5.9	15
CME806RS-32E	same	208-230/60/1	ERC201-32A	ERC402-32A	20.0	30
CME806RS-6E	same	230/50/1	ERC201-32A	ERC402-32A	20.0	30

* The remote condenser is designed to work in temperatures from -20°F. to 120°F.

Refrigerant charge for CME506R is 224 ounces; CME656R or CME806R use 232 ounces when connected to ERC201, and 280 ounces when connected to ERC402. All R-404A.

Use precharged tubing kits, RTE25 (25') or RTE40 (40').

A stacking kit to place two like cubers together is: **KSCME6-30**.

Pre-Installation

Other Applications:

The Electronic Cubers may be placed on certain Ice Dispensers, including Scotsman models: HD356, RS220 and IS220.

Check with other dispenser manufacturers for recommendations regarding application.

Check the nameplate for electrical requirements. The nameplate is located on the back of the ice machine. While the model and serial number are on the nameplate, a serial number plate is located at the front of the machine, below the metal control box.

Water:

There is no such thing as pure water. All water contains some impurities. There are two ways water carries the impurities: suspended and dissolved. Suspended solids can be filtered out. Dissolved solids must be diluted or treated. Water filters are recommended to remove suspended solids. Some filters have treatment in them for suspended solids. Check with a water treatment service for a recommendation.

Cube Ice machines use more water than what ends up in the bin as ice. While most water is used during ice making, a portion is designed to “rinse” out the water system to keep hard water scale from clogging up the machine. That water rinse, combined with water filters, prolongs the times between needed water system cleaning.

Note: All Scotsman CM³ models, like those described in this manual, feature Scotsman's AutoIQ™ control system and ReliaClean™ water system cleaning process.

Service Technicians: All models covered here come set from the factory with at a “Standard” water rinse. Standard water rinse is designed to be comparable with typical water conditions. The machine may be adjusted to a different water rinse after start up. If the prior ice machine worked acceptably well with the local water conditions, leave the machine at the factory setting. If severe water conditions are present, and water filters do not solve the problem acceptably, adjust the machine to use more water. If water conditions are excellent, adjust the machine to use less water. See the Adjustments section.

Note: Water use adjustments are customer convenience adjustments; they are NOT factory defects and are NOT covered by warranty.

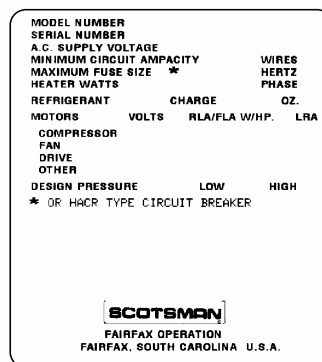

Nameplate

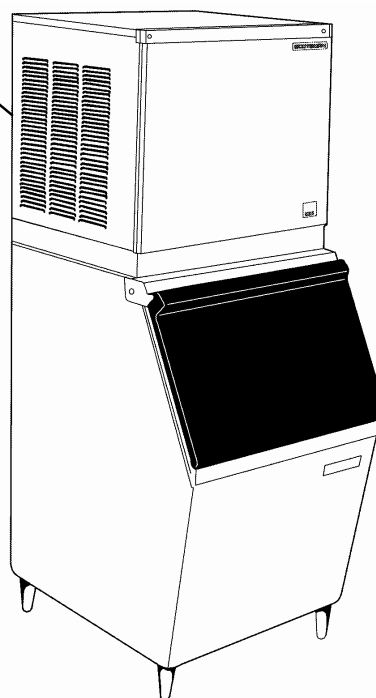

CME506R, 656R, 806R: AutoIQ Cubers

Location:

A 6 inch minimum clearance on the back, left and right sides is required for the proper operation and service of this machine.

Locate the condenser as near as possible to the interior location of the ice maker.

Select the best available location, one that protects the condenser from extremes of dust, grease and sun.

Meet all applicable building codes.

Unpacking and Assembly:

Begin with unpacking the ice storage bin. Remove the carton, and using part of the carton as a cushion, tip the bin on its back to remove the skid and attach the legs or casters. Note: Stacked applications may not use casters.

Return the bin to an upright position. Check the bin top gasket for gaps and tears, fill any in with food grade sealant prior to placing the ice machine on the bin.

If the ice machine has not been unpacked, do so now. Remove the carton from the skid. Lift the ice machine off the skid directly onto the bin.

Secure the ice machine to the bin with the hardware provided (two metal straps and 4 bolts).

After all packing materials have been removed from the ice machine, lift or hoist the machine onto the bin. Align the sides and back of the machine with the sides and back of the bin. Secure the ice machine to the bin with the two metal straps and 4 bolts provided.

Cabinet Panel Removal:

Note: The top panel holds the upper edges of the side panels in place.

1. Front Panel, “A” series: Remove the front panel by removing the four screws connecting the front panel to the left and right sides.

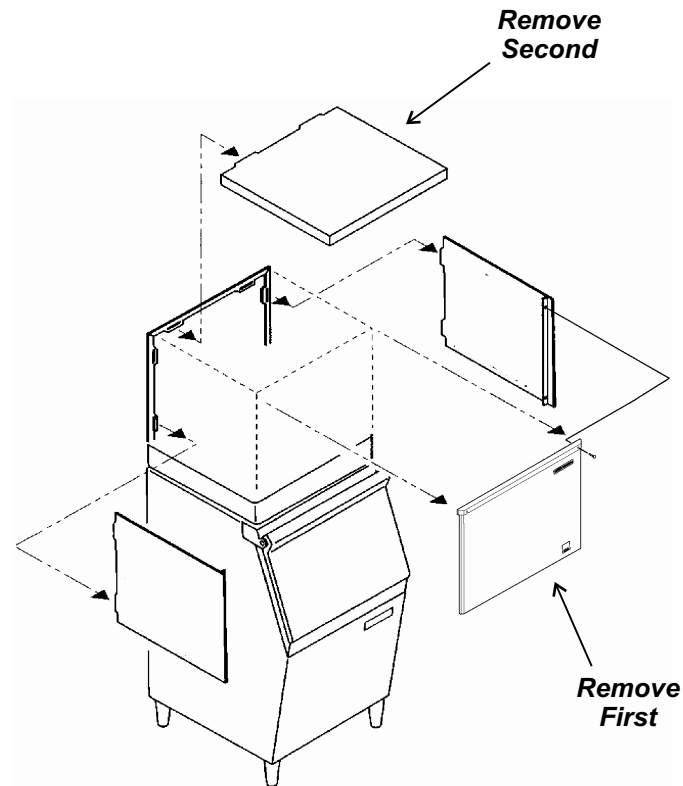

Panel Removal

Front Panel “C and D” Series: Remove top two screws and pull the bottom of the panel away from the machine to unsnap it from the machine.

2. Lift up at the front edge and pull the top panel forward until it releases from the tabs connecting it to the back panel.

3. Remove two screws at the front of each side panel, and pull them forward until they release from the tabs connecting them to the back panel.

CME506R, 656R, 806R: AutoIQ Cubers

Stacking:

Models CME256, CME506, CME656 and CME806 may be stacked together in any combination. Use kit number KSCME6-30.

1. Remove the front, left side and top panels from the bottom machine. Discard the top panel.

2. Remove the front and left side panels from the top machine.

3. Place the upper machine onto the lower machine. Check that the tabs on the top of the freezing compartment in the lower machine engage the slot in the base of the upper machine (around the cube port).

4. Fasten the upper cabinet to the lower cabinet with the hardware (two metal straps and four bolts) provided with the machine.

5. Knock out 1 hole in the upper left (viewed from the front) corner of the lower unit's back panel. Knock out the hole in the lower left (viewed from the front) corner of the upper unit's back panel.

6. Position the strain reliefs over the wrapped portion of the stacking kit wire harness.

Route the Stacking Kit Wire Harness from the back to the top and bottom machines thru the holes made in step 5. **The harness is marked which end goes to which machine.** Push the strain reliefs into place from the back of the machines.

Follow local electrical codes for 24 volt wire.

In the lower unit, route the wire behind the suction line and thru the snap bushing just below the AutoIQ Controller. Tape any excess wire to the insulated suction line.

In the upper unit, route the harness thru the snap bushing just below the Controller.

Plug one end into each Controller connection number 7.

7. Place insulation pad from the kit over the reservoir drain tubing in the upper machine. Make certain that the insulation is in contact with the tubing.

8. Return all panels to their normal places.

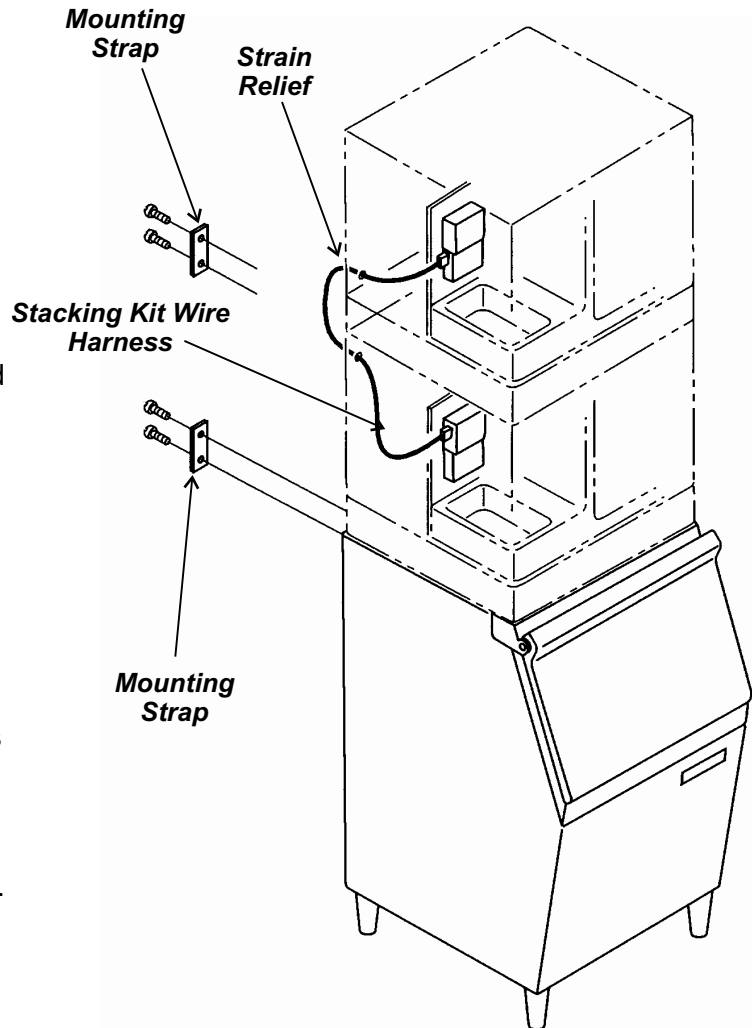

Stacking Two Ice Machines Together

CME506R, 656R, 806R: AutoIQ Cubers

Remote Condenser Location

Use the following for planning the placement of the condenser relative to the ice machine

Location Limits - condenser location must not exceed ANY of the following limits:

- Maximum rise from the ice machine to the condenser is **35 physical feet**
- Maximum drop from the ice machine to the condenser is **15 physical feet**
- Physical line set maximum length is **100 feet**.
- Calculated line set length maximum is **150**.

Calculation Formula:

- Drop = $dd \times 6.6$ (dd = distance in feet)
- Rise = $rd \times 1.7$ (rd = distance in feet)
- Horizontal Run = $hd \times 1$ (hd = distance in feet)
- Calculation: Drop(s) + Rise(s) + Horizontal Run = $dd+rd+hd$ = Calculated Line Length

Configurations that do NOT meet these requirements must receive prior written authorization from Scotsman.

Do NOT:

- Route a line set that rises, then falls, then rises.
- Route a line set that falls, then rises, then falls.

Calculation Example 1:

The condenser is to be located 5 feet below the ice machine and then 20 feet away horizontally.

$5 \text{ feet} \times 6.6 = 33$. $33 + 20 = 53$. *This location would be acceptable*

Calculation Example 2:

The condenser is to be located 35 feet above and then 100 feet away horizontally.

$35 \times 1.7 = 59.5$. $59.5 + 100 = 159.5$. *159.5 is greater than the 150 maximum and is NOT acceptable.*

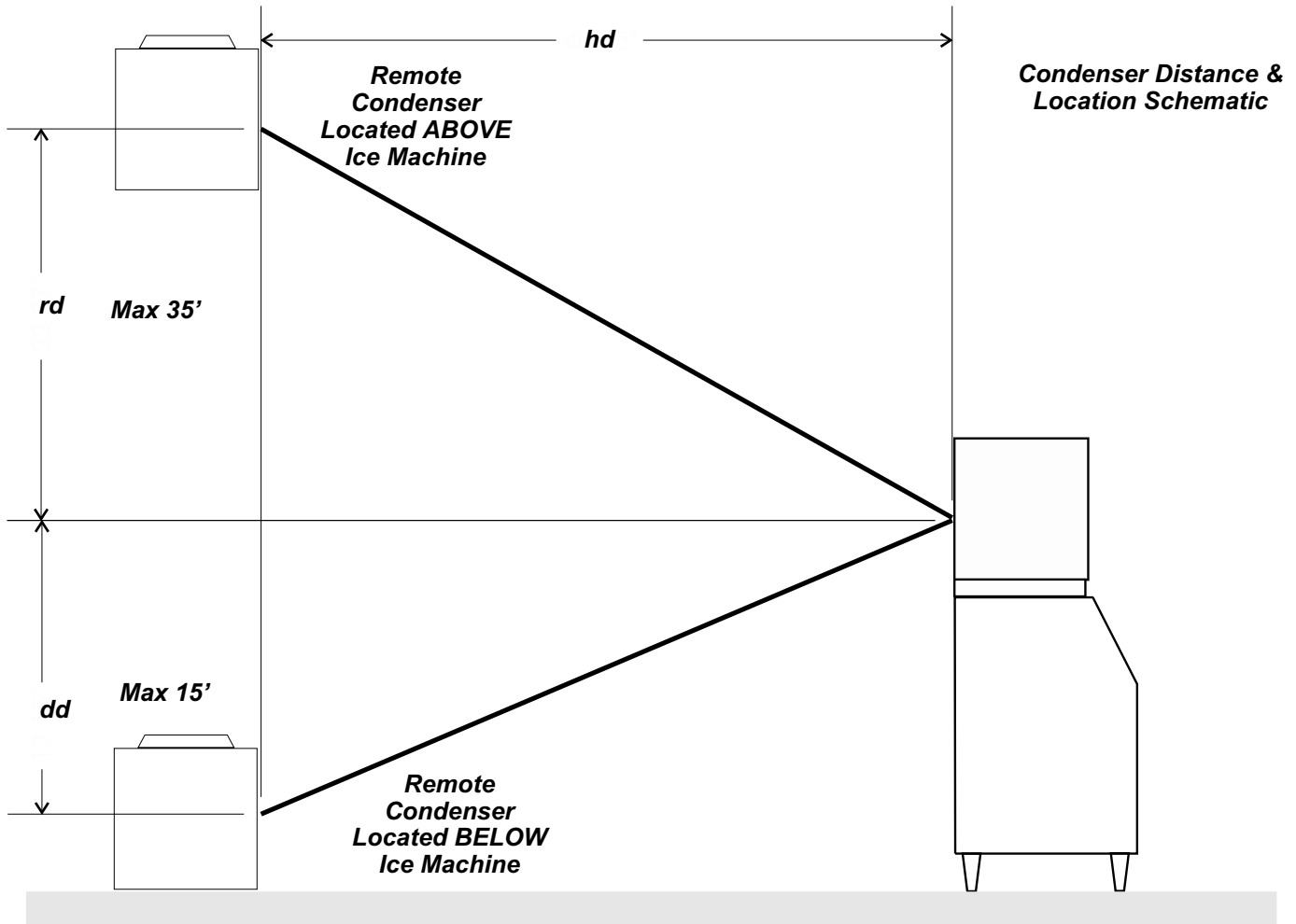

For The Installer: Remote Condenser

Locate the condenser as near as possible to the interior location of the ice machine.

If the excess tubing is to be coiled, spiral it horizontally to avoid excess trapping in the lines.

Note: The location of the condenser is relative to the ice machine is LIMITED by the specification on the prior page.

5. Have the roofing contractor seal the holes in the roof per local codes.

Meet all applicable building codes.

Roof Attachment

Install and attach the remote condenser to the roof of the building, using the methods and practices of construction that conform to the local building codes, including having a roofing contractor secure the condenser to the roof.

Precharged Line Routing

Do not connect the precharged tubing until all routing and forming of the tubing is complete. See the Coupling Instructions for final connections.

1. Each set of pre-charged tubing lines contains a $\frac{3}{8}$ " diameter liquid line, and a $\frac{1}{2}$ " diameter discharge line. Both ends of each line have quick connect couplings, the end without access valves goes to the ice maker.

Note: The openings in the building ceiling or wall, listed in the next step, are the minimum sizes recommended for passing the refrigerant lines through.

2. Have the roofing contractor cut a minimum hole for the refrigerant lines of $1\frac{3}{4}$ ". Check local codes, a separate hole may be required for the electrical power supply to the condenser.

Caution: Do NOT kink the refrigerant tubing while routing it.

3. Route the refrigerant tubes thru the roof opening. Follow straight line routing whenever possible. Excess tubing may EITHER be coiled up INSIDE the building OR cut out prior to connection to the ice maker and condenser.

If the excess tubing is cut out, after re-brazing the tubing must be evacuated prior to connection to the ice maker or condenser.

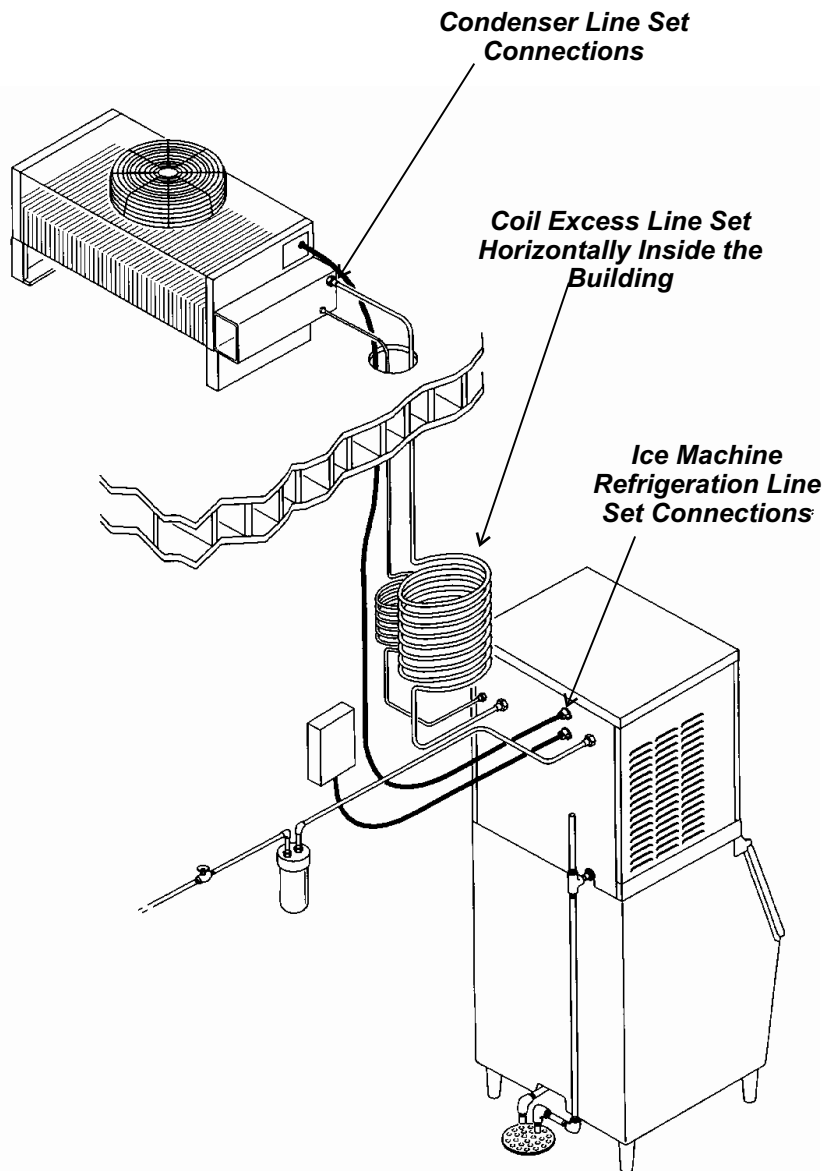

CME506R, 656R, 806R: AutoIQ Cubers

Coupling Instructions

The couplings on the ends of the pre-charged line sets are self-sealing when installed properly. Follow these instructions carefully.

These steps must be performed by an EPA Certified Type II or higher technician.

Initial Connections

1. Remove the protector caps and plugs. Wipe the seats and threaded surfaces with a clean cloth to remove any possible foreign matter.
2. Lubricate the inside of the couplings, especially the O-rings, with refrigerant oil.

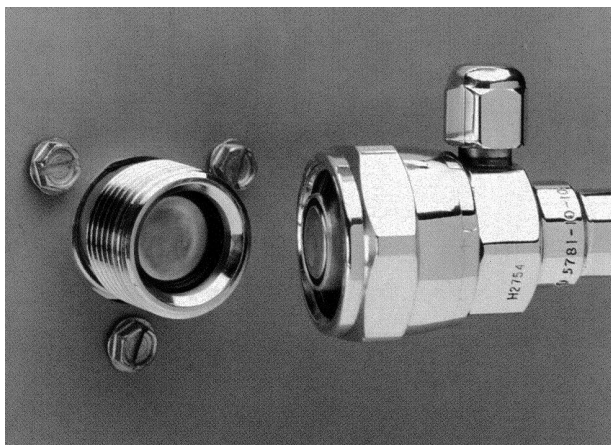

Clean and Lubricate Couplings

3. Position the fittings on the correct connections on the condenser and ice machine.
 - The $\frac{1}{2}$ " discharge line (schrader valve end) goes to the remote condenser fitting marked "discharge line".
 - The $\frac{3}{8}$ " liquid line (schrader valve end) goes to the remote condenser fitting marked "liquid line".
 - The $\frac{1}{2}$ " discharge line goes to the ice maker fitting marked "discharge line".
 - The $\frac{3}{8}$ " liquid line goes to the ice maker fitting marked "liquid line".

Final Connections:

- 4a. Begin by tightening the couplings together by hand until it is certain that the threads are properly engaged.
- 4b. Then using two wrenches tighten the coupling until it bottoms out or a definite increase in resistance is felt.

It is important that ONLY the nut on the pre-charged tube be turned, or the diaphragms will be torn out by the piercing knives and they will be loose in the refrigeration system.

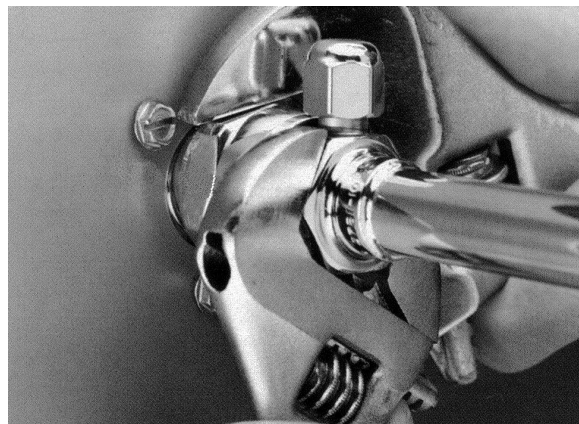

Tighten Swivel Nut

Note: As the couplings are tightened, the diaphragms in the quick connect couplings will begin to be pierced. As that happens, there will be some resistance to tightening the swivel nut.

- 4c. Continue tightening the swivel nut until it bottoms out or a very definite increase in resistance is felt (no threads should be showing).



Rotate Swivel Nut $\frac{1}{4}$ Turn More

5. Use a marker or pen to mark a line on the coupling nut and unit panel. Then tighten the coupling nut an additional one-quarter turn. The line will show the amount that the nut turns. Do NOT over tighten.
6. After all connections have been made, and after the king valve has been opened (do not open yet), check the couplings for leaks.

CME506R, 656R, 806R: AutoIQ Cubers

Electrical:

All models must be installed with the correct wire size and type per the National Electric Code. Locate the nameplate on the back of the cabinet and find the numbers for Voltage, Phase, Minimum Circuit Ampacity and Maximum Fuse Size. Either fuses or HACR type circuit breakers may be used.

The ice maker is designed to operate on its own electrical circuit and must be individually fused. Voltage variation must not exceed the limits listed on page 2.

The remote condenser is designed to be powered from the ice machine. A separate knockout hole has been provided in the ice maker electrical junction box.

Electrical connections are made in the junction box in the back of the cabinet.

1. Remove the junction box cover.

2. Knock out both holes for a field supplied strain relief.

3. Install wires and strain reliefs per code. Note: Condenser fan motor wires are tagged.

4. Connect to wires and secure ground wire to ground screw inside junction box.

All external wiring should conform to the national, state and local electrical code requirements. Usually an electrical permit will and the services of a licensed electrician will be required.

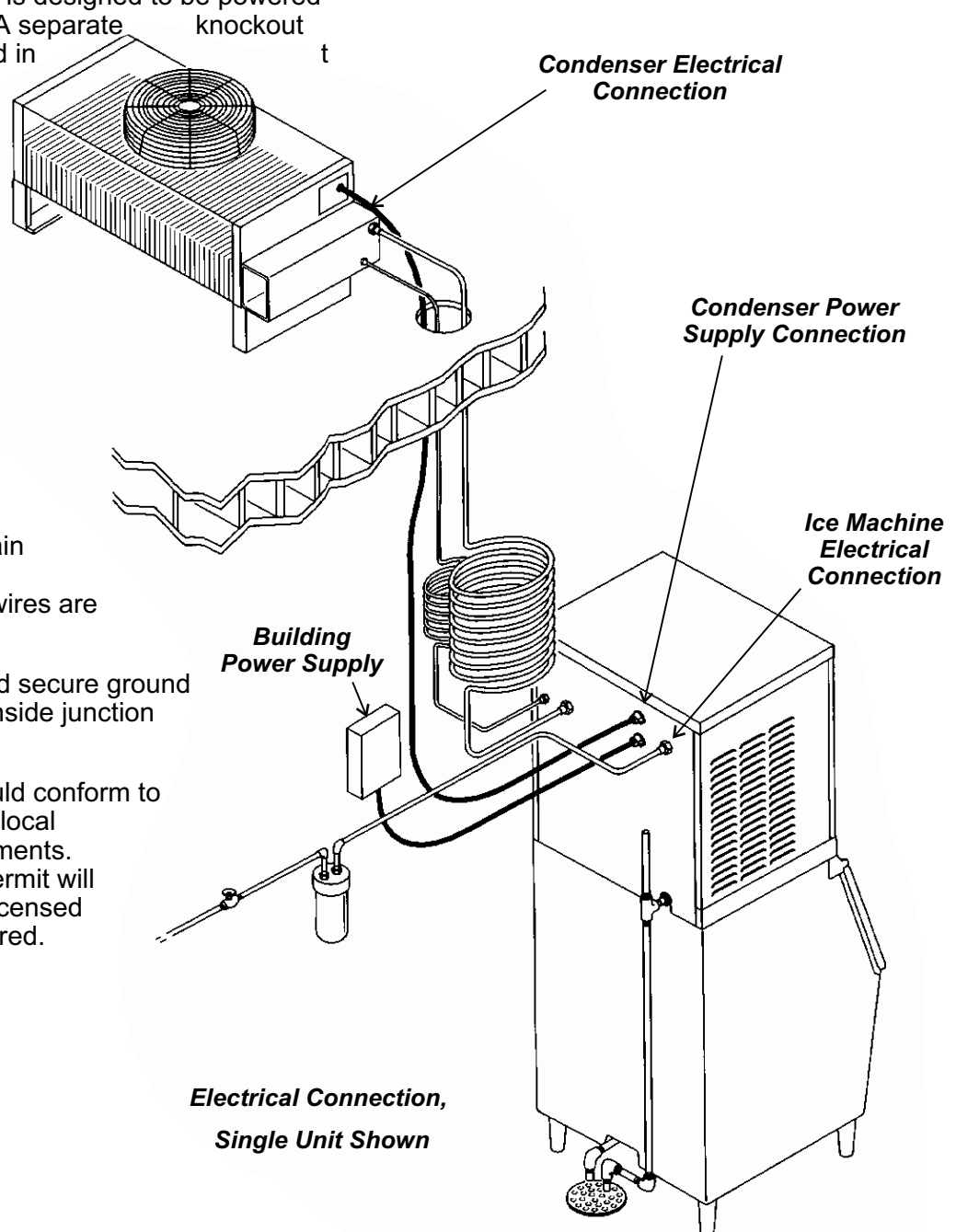

CME506R, 656R, 806R: AutoIQ Cubers

Electrical Connections: KCMR230 Fan Relay Kit (CME656R & CME806R only)

When 2 ice machines are connected to 1 remote condenser coil, and the fan motor is powered from the ice machines, a relay kit is required to connect power to the fan motor.

1. Attach the relay box of the KCMR230 to a location that is convenient for installation and future service.
2. Attach a solid earth ground wire to the ground screw.
3. Route the connecting wires from the first ice machine's fan wires to the relay kit terminal strip posts marked: No. 1 Ice Machine.
4. Route the connecting wires from the second machine's fan wires to the relay kit terminal strip posts marked: No. 2 Ice Machine.
5. Attach wires at the fan relay kit terminal strip marked: To Remote Fan, and route them to the remote condenser electrical connection.
6. Make the proper electrical connection at the junction box.

Conform to all applicable codes.

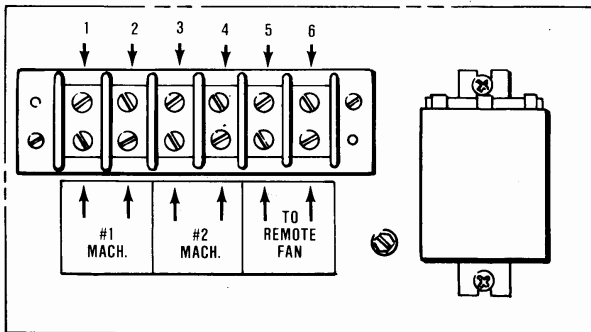

KCMR230 RELAY BOX

Phasing: To be certain that a reliable installation of the KCMR230 kit has been accomplished, a check of the electrical phasing is required.

The goal is to have each set of points in the relay "break" the one power "leg" - so there is no voltage potential when switching.

Note: 3 phase machines must have the same "leg" or line connected to L3 on BOTH ice machines contactors, and if there is a "wild leg" it must be connected to L3 on BOTH ice machines.

A. Before initial start up. Compare the illustration of the KCMR230 terminal strip to the connections at the KCMR230:

- Terminals 1 and 3 must be connected to a common leg (such as L1).
- Terminals 2 and 4 must be connected to a common leg (such as L2).

B. After initial start up, test with a volt meter (compressors must be ON).

1. Switch on ice maker #1, then ice maker #2.
2. Test with a volt meter between terminals #2 and #4, then between terminals #1 and #3.

List the voltages and compare to the table:

If there is full voltage where there should be NO or little voltage:

Test Terminals	Voltage Should Be	Tested Voltage Was:
1-2	Full	
1-3	No voltage	
2-3	Full	
2-4	No voltage	
3-4	Full	
1-4	Full	

Switch off ice maker number 2, and then switch off ice maker number 1.

After the units have pumped down, disconnect the electrical power. Do all wiring with the electrical power disconnected to BOTH ice makers at the source.

Reverse the connections at the KCMR230 terminal strip marked ice maker #1 (put the wire that was on terminal 1 on 2 and the wire that was on terminal 2 on 1).

Reconnect electrical power.

CME506R, 656R, 806R: AutoIQ Cubers

Plumbing:

All models require an adequate potable water supply and a gravity drain. The recommendations for tubing are: Water supply to be $\frac{3}{8}$ " OD. Drain to be $\frac{3}{4}$ " OD.

Supply:

All models have 1 water supply connection, a $\frac{3}{8}$ " male flare at the back of the cabinet.

Drain:

All models have 1 gravity drain connection, a $\frac{3}{4}$ " FPT fitting at the back of the cabinet.

It must be vented at the back of the cabinet.

The ice storage bin will have a drain out the back or base, depending upon the model. Note: Scotsman HTB555 (shown in this manual) may be drained either out the back or the base.

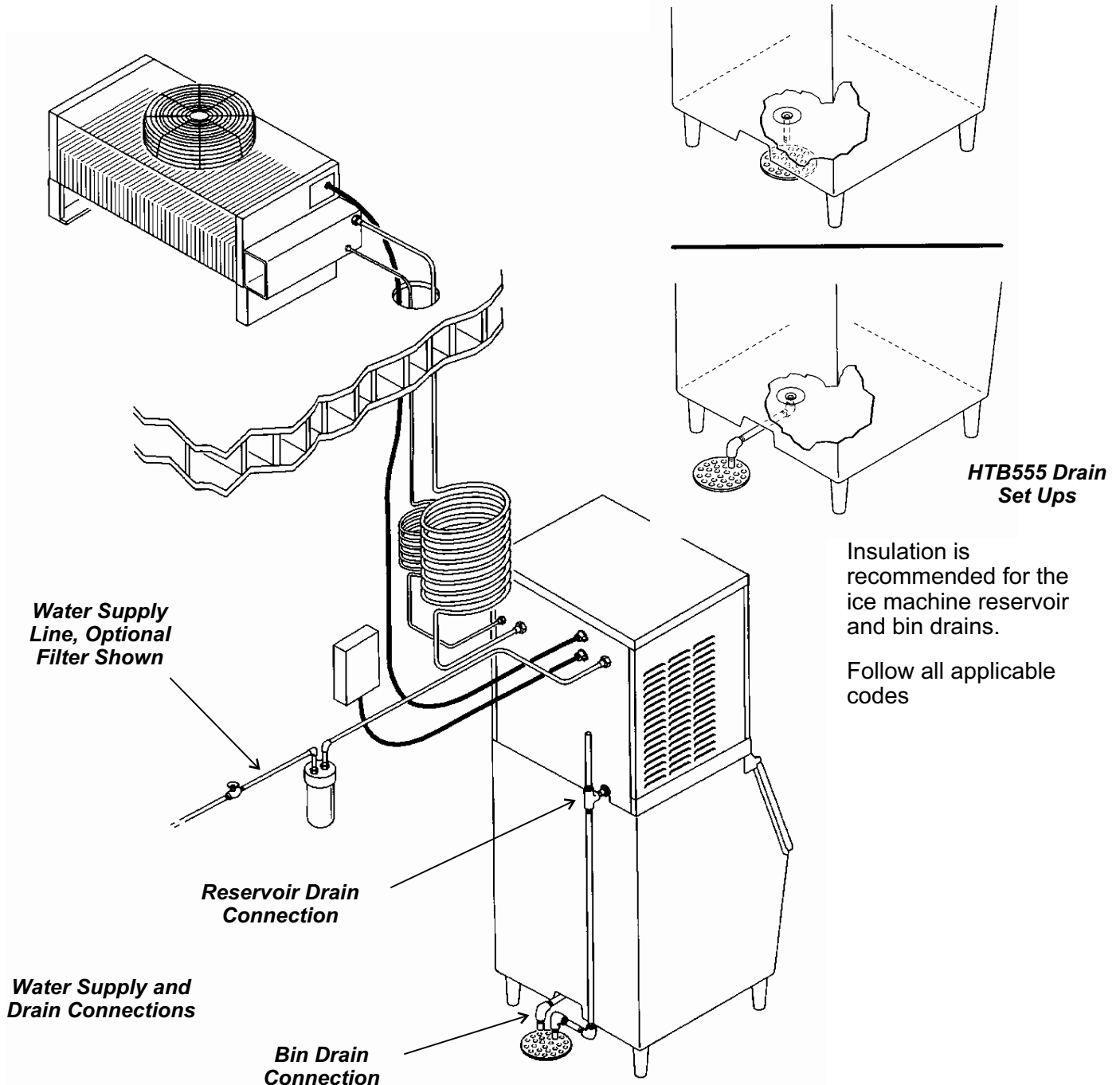

CME506R, 656R, 806R: AutoIQ Cubers

After Utility Connections:

1. Level the cabinet, use the leg levelers on the end of the legs to adjust the cabinet height.
2. Wash out the bin. If desired, the interior of the bin could be sanitized.
3. Locate the ice scoop (if supplied) and have it available for use when needed.
4. Switch on the electrical power. Do not start the machine for 4 hours.

Final Check List:

1. Is the unit located indoors in a controlled environment?
2. Is the unit located where it can receive adequate cooling air?
3. Has the correct electrical power been supplied to the machine?
4. Have all the water supply connections been made?
5. Have all the drain connections been made?
6. Has the unit been leveled? Level the unit at the water reservoir.
7. Have all unpacking materials been removed?
8. Is the water pressure adequate?
9. Have the drain connections been checked for leaks?
10. Has the bin interior been wiped clean or sanitized?
11. Have any water filter cartridges been replaced?
12. Check all refrigerant lines and conduit lines, for vibration or rubbing and possible failure. Adjust as needed.
13. After 4 hours of electrical power, proceed to Initial Start Up.

CME506R, 656R, 806R: AutoIQ Cubers

Component Location and Function:

Reservoir: Contains the water charge used for every batch of ice.

Water Inlet Valve: Opens to allow water into the reservoir.

Water Level Sensor: Controls size of ice cube by measuring how much water is used in a cycle. It consists of a float, stem and electric eye. As the machine is pumping water during ice making, the stem will be seen moving slightly. This is normal. As the machine makes ice the visible portion of the stem will slide down thru the slot in the sensor body.

AutoIQ Controller: Controls the complete operation of the ice machine. Turns it on and off; switches it between cycles; shows information via indicator lights; and shuts the machine down if there is a problem.

Evaporators/Freezing Compartment: Ice making area. Ice forms on the evaporators, and is released when warmed up during the harvest cycle. The freezing compartment is fully insulated for maximum efficiency.

Cube Deflector: The slots in the inclined deflector allows the water falling from the evaporators back into the reservoir, but when ice falls during harvest, the ice slides off the deflector into the bin.

Refrigeration Service Access Valves: Only to be used by a certified technician. Allows access to the refrigeration system for diagnostic information.

Water Pump: Forces the water from the reservoir to the top of the evaporator(s). The motor is kept separate from the water to minimize contact with the water.

Compressor: The refrigerant vapor pump, it forces the refrigerant to flow thru the refrigeration system tubing.

Hot Gas Valve: Closed during freeze, it opens during harvest to divert hot discharge refrigerant gas into the inlet of the evaporators.

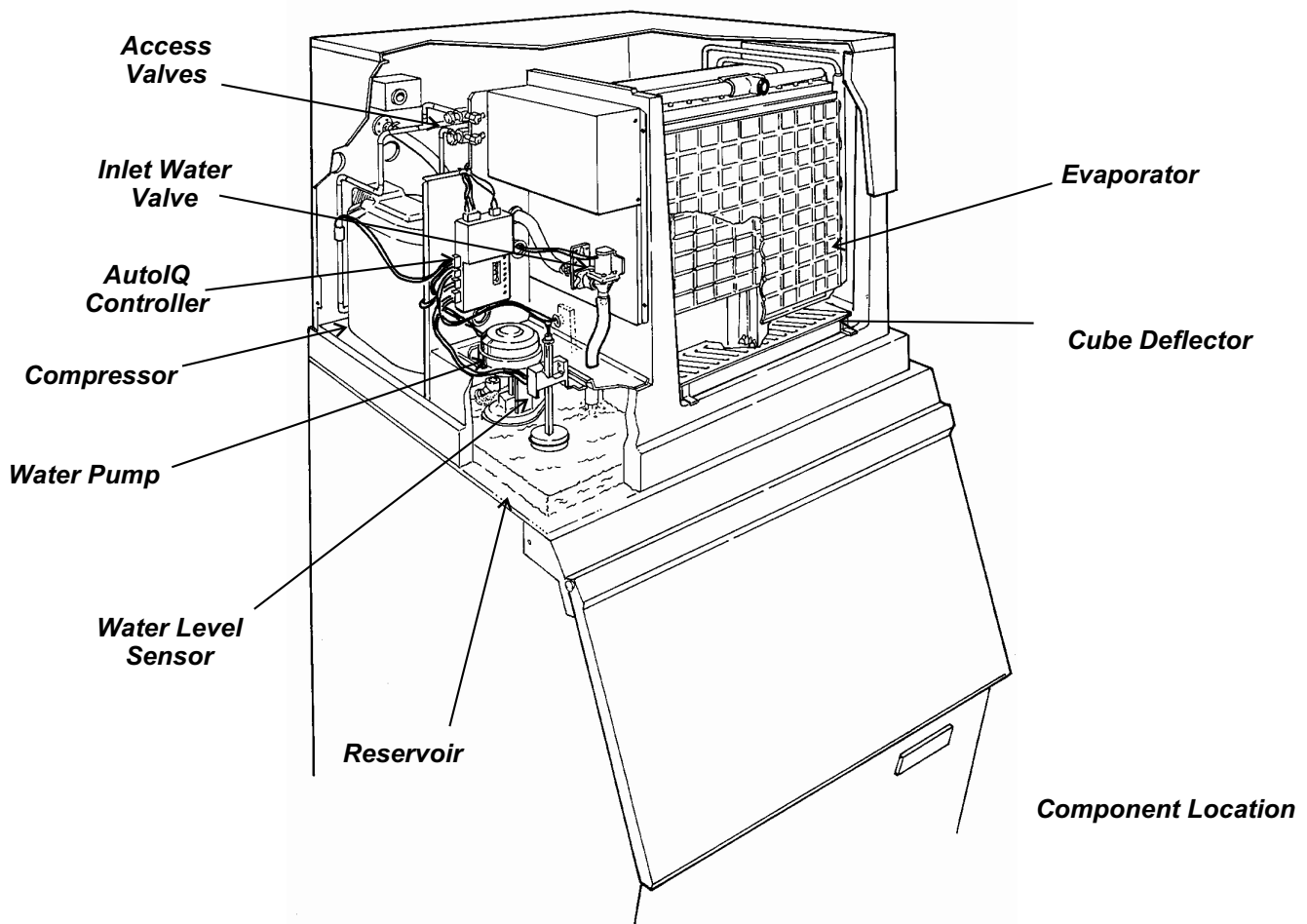

CME506R, 656R, 806R: AutoIQ Cubers

AutoIQ Controller:

Indicator Lights:

- **Bin Full:** On when bin is full, goes on and off as ice falls during a harvest cycle.
- **Freeze:** On when the unit is in the Freeze cycle, blinks when a freeze cycle is pending.
- **Harvest:** On when the unit is in the Harvest cycle.
- **Clean:** On when the unit is in the Clean cycle.
- **Off:** On when the unit has been switched off, blinks when the machine is preparing to shut off.
- **Water Error:** On when the controller has identified a problem with the water system.
- **Refrigeration Error:** On when the controller has identified a problem with the refrigeration system.

Cycle Definitions:

- **Freeze:** The refrigeration system is operating to remove heat from the evaporators. The compressor, remote fan motor and water pump are ON.
- **Harvest:** The refrigeration and water systems are operating to harvest the ice cubes. While the compressor and fan motors are on for the full cycle, the water pump will be off at the beginning and the inlet water valve will switch off before the end.
- **Clean:** Water valve opens to fill the reservoir. The Water pump starts. The Clean indicator light is switched ON. A manually initiated rinse cycle flushes the system.

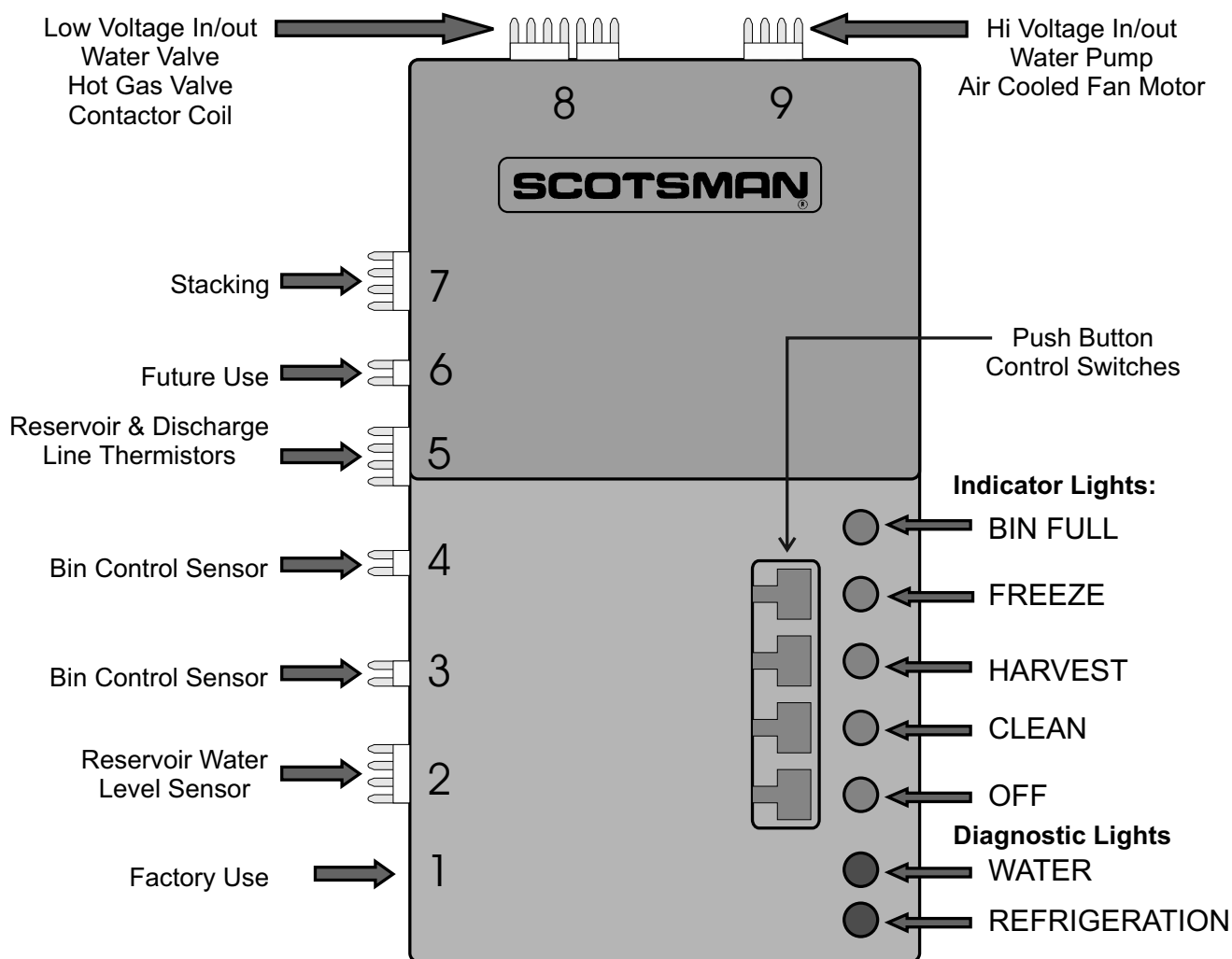

Initial Start Up:

1. Remove the front, top and side panels.
2. Locate and open the receiver “king” valve.
3. Locate the AutoIQ Controller.
4. Switch on the electrical power. Note that the LED or indicator lights all flashed on briefly.
5. Open the water supply valve.
6. Push and release the Freeze cycle push button (the Freeze indicator light will blink until the compressor starts). The next several operations are automatic.

Initial Start (30 seconds)

- The Freeze light will begin to blink.
- The Hot Gas Solenoid valve will be open.
- The inlet water valve will open to fill the reservoir. The inlet water valve will shut off when the reservoir is full.
- The water pump starts to pump water.
- The water solenoid opens again to refill the reservoir.
- After 30 seconds the liquid line valve is energized, allowing the compressor & remote fan motor to start.
- 5 seconds later the hot gas valve closes.

Freeze Cycle:

- The Freeze indicator light will come on. The machine will stay in a Freeze cycle for many minutes. Slush may appear in the reservoir, it is temporary and normal.
- Under certain conditions, the pump may stop for a few seconds and then the inlet water valve may open to refill the reservoir.
- The freeze cycle will continue until the water level in the reservoir drops to its factory set point, then the Harvest Cycle will begin.

Harvest Cycle:

- The Harvest indicator light will be ON,
- The hot gas valve will open.
- The water pump will switch off. The pump will restart part way thru the harvest cycle.
- The Inlet water valve will open. The machine will fill the reservoir and overflow it for a specified number of seconds then shut off. The harvest cycle may still be in progress.
- The Bin Full indicator light will go on and off as ice falls from the evaporators.

7. Machines are shipped from the factory with the purge level set to accommodate average water conditions. To achieve optimal machine performance, set the purge level to the minimum setting.

Note: While the amount of water purge is adjustable, only those installations with a water supply known to be excellent (very low TDS) should adjust to the minimum setting. See page 16 for purge adjustment procedures.

8. The machine’s correct cube size should result in ice that falls from the evaporator in vertical strips of 8 - 10 cubes, the top two cubes may fall individually.

9. After a few minutes the machine will return to a freeze cycle.

10. Fill out the Customer Evaluation and Warranty Registration. Send it to Scotsman.

11. Return all panels to their normal positions.

12. Inform the user of the location and telephone number of the local service company. Also inform the user of the required maintenance of the machine.

Operational Notes:

1. The machine will only shut off on Bin Full at the end of the Harvest Cycle after the bin fills. That last harvest cycle will be for Maximum Harvest Time.
2. After switching off on Bin Full, if ice is removed from the bin, the machine will not restart until it has been off for 5 minutes. If the Freeze button is pushed, the machine will restart immediately.
3. If the bin controls sense a bin full signal before any water is used (float stem up), the machine will shut off on bin full.

CME506R, 656R, 806R: AutoIQ Cubers

Adjustments:

If there was a problem during Initial Start Up:

If an error light came on, check the following.

1. Water error.

A water error could have been determined by the AutoIQ Controller if the inlet water valve does not fill the reservoir or if the water pump does not start and lower the water level in the reservoir. If either condition is found, the water error light will be switched on and the machine will Shut Down.

2. Refrigeration error.

A refrigeration error could have been determined by the AutoIQ Controller if the water temperature did **not** drop during the freeze cycle. The Controller will next check the compressor discharge temperature. If the discharge temperature is too low, the refrigerant error light will be switched on, and the machine will Shut Down.

Note: The machine can be reset and restarted by pushing and releasing the Off push button switch, and then pushing and releasing the freeze push button switch.

How to Adjust Cube Size (Reference Only)

The adjustment is done by moving the long screw located in the floating stem at the front of the machine.

Note: Units manufactured beginning 3/97 do not have a cube size adjustment screw. Their cube size is fixed.

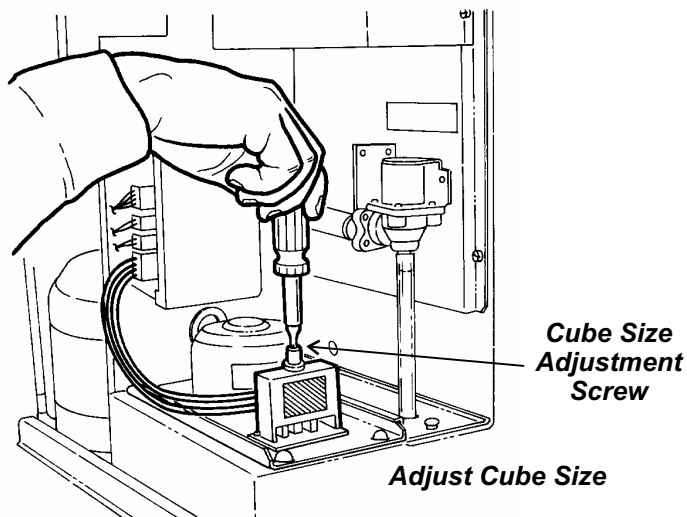

1. Remove the front panel.

2. Hold the stem with one hand, and

To increase the cube size, turn the screw out (counter clockwise)

To decrease the cube size, turn the screw in (clockwise)

Turn the screw 2 turns at a time.

3. Check cube size after the next freeze cycle, repeat step 2 if needed.



Side View, Cube should be 1/2" thick at the center.

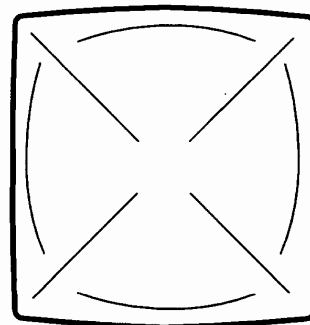

Front View, cube is 1.5" x 1.4"

Adjustments:

Thermostatic Expansion Valve:

The TXV is not adjustable, do not attempt to adjust it.

How to Adjust the Amount of Water Purge

Adjustment is done by use of the control buttons on the AutoIQ Controller. Examine the next section to become familiar with the AutoIQ Controller before beginning.

1. If the machine is on, push and hold the OFF button for more than 3 seconds, then release it. This switches the machine Off.
2. Push and hold the OFF button for more than 3 seconds (just until all LEDs flash on) then release it. Do not hold it in it too long.
3. Examine the green LEDs. They should have all flashed once, then certain ones will have turned on to indicate which purge level the machine is set at. There are 5 levels of purge available:

- 1. **Maximum Purge** is when All 5 lights are ON. Use for extreme water conditions. Note: This setting may extend the Harvest cycle and reduce capacity.
- 2. **Heavy Purge** is when these 4 lights are ON: Freeze, Harvest, Clean, Off. Use for moderate to severe water conditions. This setting may extend the Harvest cycle and reduce capacity.
- 3. **Standard Purge** (factory setting) is when these 3 lights are ON: Harvest, Clean, Off. Use for typical water conditions.
- 4. **Moderate Purge** is when these 2 lights are ON: Clean, Off. This is for good water conditions.
- 5. **Minimum Purge** is when this light is ON: Off. For excellent water conditions.

Adjust by pushing and releasing the Freeze button. Pushing and releasing the Freeze button increases the purge one level up to the maximum, then it goes to the minimum.

4. The machine will automatically restart after 60 seconds of no switch inputs, or restart the machine by pushing in and holding the Off button for more than 3 seconds, then releasing it. The unit will then be Off. From there the machine may be placed in a freeze cycle by pushing and releasing the Freeze button.

CME506R, 656R, 806R: AutoIQ Cubers

How To Operate The AutoIQ Controller

The AutoIQ Controller is a microprocessor based device that receives input from several sources and switches various components on and off.

Its manual control is thru the use of the Push Button Control Switches

1. **Freeze Button.** Pushing and releasing this button starts or restarts the machine. The AutoIQ Controller remembers what cycle it was last in and returns to that cycle.

2. **Harvest Button:** Pushing and releasing this button will cause the machine to go directly to a Harvest Cycle. Can be done from Freeze or Off. The machine will switch Off at the end of the Harvest cycle.

3. **Clean Button:** Pushing and releasing this button will cause the machine to only power the water pump for circulation of ice machine cleaner. After the ice machine cleaner has circulated for about 10 minutes a second push of this button will switch on the rinsing system to flush out the dissolved scale and ice machine cleaner.

4. **Off Button:** Pushing and releasing this button will switch the machine OFF at the end of the next cycle. If the button is pushed and HELD for more than 3 seconds, the unit will switch off immediately.

To Reset: First push and release the Off button, then push and release the Freeze button.

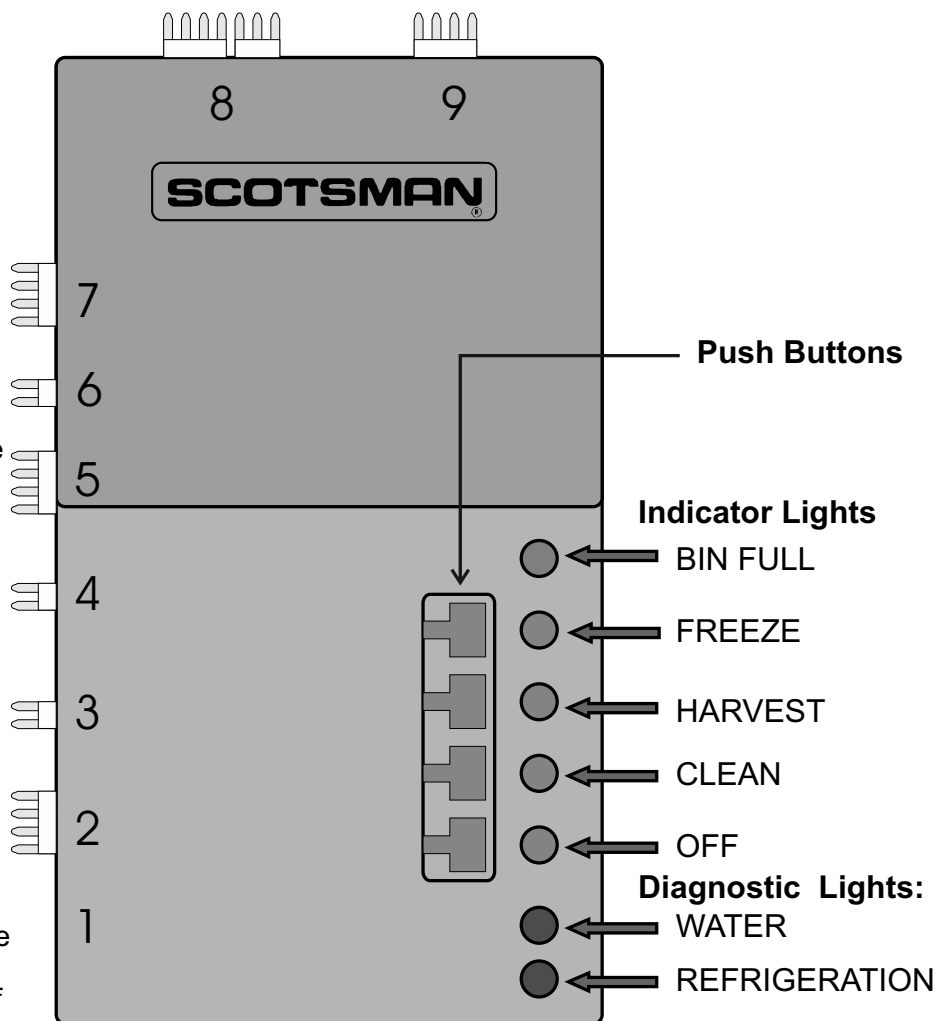

How The Electronic Cuber Works

This section is intended for the technician. It is not necessary for the normal operation and maintenance of the machine.

The AutoIQ Controller operates the ice machine by monitoring several input measures and switching various loads on and off.

Water System:

Water flows into the ice machine during the harvest cycle from thru the inlet water valve. The water valve will NOT be open the complete length of the harvest cycle. The water pump operates whenever the machine is on, and it forces water to the top of the evaporators. The un-frozen water falls thru the cube deflector and back into the reservoir. As water is turned into ice, the water level in the reservoir falls, and at the point where the cubes are fully formed, the water level sensor indicates to the AutoIQ Controller that it is time to begin the Harvest cycle.

During the Harvest cycle, water again enters the water reservoir, and overfills it to rinse the reservoir of accumulated minerals. It does NOT overflow for a fixed amount of time, but for a time determined by the AutoIQ Controller.

The water pump will be off for a short period of time at the beginning of Harvest.

Refrigeration System:

The refrigeration system is similar to that of most commercial cube ice machines. Heat is removed from the water and discharged out the condenser during the freeze cycle. As liquid refrigerant passes thru the Thermostatic Expansion Valve, it enters the bottom of the evaporators, and will form on the bottom first. When cubes need to be released (Harvest) the Hot Gas Bypass Valve is opened and Hot discharge gas flows directly from the compressor to the evaporator inlets. This warms up the evaporators and the surface of the ice frozen to the evaporator surface melts. Ice then falls into the bin.

Controller Inputs:

1. **Reservoir water temperature.** This is measured by a thermistor located in the water pump outlet.
2. **Discharge line temperature.** This is measured by a thermistor located on the compressor discharge line.
3. **Water level.** This is measured by an infrared sensor and float. The float rises and falls with the water level, and switches the sensor on and off as it moves.
4. **Bin fill level.** This is measured by a set of electric eyes in the cube outlet port. If ice fills the bin, it will block the "eyes".
5. **Time.** The controller measures and compares how long it takes for various events to happen. It stores that data for future reference.

Controller Outputs:

A. 24 volt:

- 1. LEDs
- 2. Inlet water valve
- 3. Hot Gas Valve
- 4. Contactor Coil
- 5. Liquid Line Valve Coil

B. High Voltage

- 1. Water Pump

CME506R, 656R, 806R: AutoIQ Cubers

Technicians Only: Freeze Cycle Operational Sequence

Assuming the machine has been operational, the Freeze cycle begins with the end of the Harvest Cycle:

- Water level overflowing
- Water Inlet Valve is OFF
- Water Pump is ON
- Liquid Line Valve is OPEN
- Pump Down Control is CLOSED
- Compressor is ON
- Hot Gas Valve is ON (plus 5 seconds after start of Freeze on D series)

AutoIQ Controller Operation, Beginning freeze:

1. Switches on Freeze indicator light and shuts off the hot gas valve.
2. Measures and stores the discharge temperature.
3. If the discharge temperature exceeds the design maximum, shuts the machine down on a Refrigeration Error.
4. Checks for a "bin full" signal throughout the cycle.
5. Measures the reservoir water temperature. If the machine is operating correctly, the reservoir water temperature will fall at a standard rate. The AutoIQ Controller will be checking to see if the water temperature fall matches that rate.

If not, it re-checks the discharge line temperature. If too low, it Shuts Down on a Refrigeration Error. If the discharge temperature is acceptable, the water system is checked by shutting off the water pump and determining if the water level goes up enough. If it does not, the inlet water valve will open again to fill it. If, after restarting, the water level does not drop, it is assumed that there is a water pump problem and the machine Shuts Down on a Water Error.

If the water level does "measure up" the water pump is restarted and the AutoIQ Controller then measures how long it takes to lower the water level. If the water level does not fall, the machine Shuts Down on a Water Error.

6. Once per freeze cycle the machine may shut off the water pump. It **only** does this when the water temperature reaches a preset minimum. The pump will only be off for a few seconds. After the pump restarts, the inlet water valve will open to refill the reservoir.

7. As the machine makes ice, the water level in the reservoir will ultimately fall to the Harvest Level. Note: If the freeze cycle exceeds the preset Maximum, the AutoIQ Controller will Shut Down on a Refrigeration Error.

8. The end of Freeze cycle will see the machine in this state:

- Water level = below harvest position
- Water inlet valve will be off
- Water pump will be ON
- Compressor will be ON
- Hot gas valve will be off

At this point Harvest begins and the AutoIQ Controller switches the Harvest indicator light ON.

Note: If there is a power interruption, the machine will restart and go thru a Harvest cycle.

Technicians Only: Harvest Cycle Operational Sequence

Harvest

The water valve opens and fills the reservoir to the Full level.

The water pump shuts off. It will restart in less than a minute.

Note: Machines built after August 1996:

- If the machine remains in the harvest cycle for longer than between 6 -9 minutes (depending upon the regular harvest cycle's length) the water pump will be switched off until the next freeze cycle.
- When the bin is full and the unit is in a harvest cycle, the pump will be switched off.

The AutoIQ Controller checks how long it takes to fill the reservoir, and if it was too much time, the machine Shuts Down on Water Error.

Note: The machine will automatically attempt to restart after shutting down because of a lack of water. The time between restarts is about 30 minutes.

The inlet water valve will stay on and open for a predetermined fraction of the time it took to fill the reservoir. This overflows and rinses the reservoir water.

During the Harvest Cycle, ice will be falling from the evaporators and between the bin control's electric eyes. The AutoIQ Controller monitors the ice falling and stays in the Harvest Cycle until ice quits going thru the electric eyes.

The maximum harvest time is 10 minutes. Harvest time is varied by the AutoIQ Controller based the time it took the last batch of ice to fall.

The first Harvest after a restart will take about 5 minutes to establish a base line, then the time it took to release that ice is used to determine the next harvest cycle's length.

If no cubes fall (or are sensed) by the end of the Maximum Harvest Time, the machine senses a Refrigeration Error. If the next cycle also produces a Refrigeration Error, the machine will shut down.

Note: Machines built up to August 1996: The last Harvest cycle before shutting off on Bin Full will be 10 minutes. **All CME806 and all other machines built after August 1996 have a last harvest cycle that is 4-6 minutes long.**

Note: The machine will not restart for 4 minutes after switching off on Bin Full, unless the Freeze button is pressed.

Stacked Units:

If the bottom unit is in harvest and receives a signal from the top unit that it is also in Harvest, the bottom unit will stay in harvest for its Maximum Harvest Time.

Diagnostic Lights and Manual Resets

The controller will shut the machine off if a malfunction is sensed. Controllers up to 17-1 will shut the machine off after the first malfunction. Controllers marked 17-1 and up will restart the machine 2 times, with a 50 minute interval between restarts.

If a malfunction is still present after the second restart, the machine will then shut off and must be manually reset. During the restart interval, the machine will be off and a diagnostic code indicated.

An exception to this is lack of water. When switched off because of lack of water, the machine will always try to re-fill the reservoir every 20 minutes.

Another exception is a harvest error. As before, there must be two consecutive harvest errors to trigger a machine shut-down. With this change, the controller will still shut down and restart the machine after two consecutive harvest errors. However, if the errors repeat two more consecutive times, the controller will shut down and restart the machine again. If the machine registers two more consecutive harvest errors, the machine will again shut down and must be manually reset.

Production of units with Controllers 17-1 began approximately March 1997.

CME506R, 656R, 806R: AutoIQ Cubers

Sanitation and Cleaning

It is the User's responsibility to keep the ice machine and ice storage bin in a sanitary condition. Without human intervention, sanitation will not be maintained. Ice machines also require occasional cleaning of their water systems with a specifically designed chemical. This chemical dissolves mineral build up that forms during the ice making process.

Sanitize the ice storage bin as frequently as local health codes require, and every time the ice machine is cleaned and sanitized.

The ice machine's water system should be cleaned and sanitized a minimum of twice per year.

In Place Cleaning of the Ice Machine Water System:

1. Remove all ice from the bin. Either save it in a sanitary container or discard it. If the cleaning was planned, the ice machine could be switched off the night before to minimize waste.
2. Remove the front panel.
3. Push and release the Harvest button (this releases any ice that may be on the evaporators and warms them up).
4. Wait for the machine to finish the Harvest cycle (the machine will stop).
5. Remove the cube deflector, the evaporator cover, the cascading shield (if used) and the bin control sensors. Place the cascading shield and the cube deflector in a separate container. Place the bin controls in the reservoir.
6. Push and release the Clean button. The Clean indicator light will be blinking, and the pump will restart.
7. Pour 12 ounces of Scotsman Ice Machine Cleaner into the reservoir water. Return the evaporator cover to its normal position.

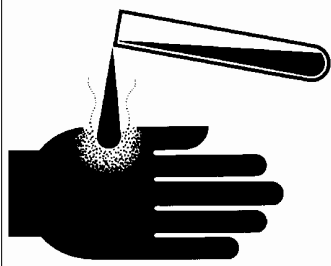
CAUTION	Scotsman Ice Machine Cleaner contains acids. Acids may cause burns.
	If concentrated cleaner comes in contact with skin, flush with water. If swallowed, do NOT induce vomiting. Give large amounts of water or Milk. Call Physician immediately. Keep out of the reach of children.

8. Mix a solution of 8 ounces of Scotsman ice machine cleaner and 1 gallon of warm (95-115°F.) water. Use the solution to scrub the cascading shield and cube deflector in the separate container.
9. After the ice machine cleaner has circulated for 10 minutes, push and release the Clean button.

This starts the rinsing process. The Clean indicator light will be ON. Note: The rinse process flushes any residual cleaner out of the ice machine's water system.

10. Continue the rinsing process for 20 minutes, then push the off button to switch the machine off.
11. Go to the next step to sanitize the machine or go to step 19 to finish the cleaning process.
12. Mix 2 gallons of Sanitizer solution. Follow local codes for Sanitizer.

Note: A possible sanitizing solution may be made by mixing 1 ounce of liquid household bleach with 2 gallons of warm (95-115°F.) potable water.

13. Push and release the Clean button again.
14. Pour 16 ounces of Sanitizer solution into the reservoir water.

Pour Cleaner in Reservoir



15. After the solution has circulated for 10 minutes push and release the Clean button. This starts the rinse process. Sanitize the ice storage bin while waiting. <P10.5>
16. Continue the rinsing process for 20 minutes, then push the off button to switch the machine off.
17. Remove the evaporator cover and spray or wash all interior surfaces of the freezing compartment including the evaporator cover with sanitizer solution.
18. Thoroughly immerse the cascading shield and cube deflector in the sanitizing solution.
19. Return the bin controls, cascading shield and cube deflector to their original positions.
20. Return the evaporator cover to its original position. Push and release the Freeze button.
21. Return the front panel to its normal position and secure it to the machine with the original screws.

Additional Maintenance

To drain reservoir completely:

1. Remove front panel.
2. Push and hold the Off button.
3. Remove screw holding reservoir cover, pull inlet tube out of reservoir cover, lift cover out of machine.
4. Unplug water pump connection, remove ground screw.
5. Remove float from float stem.
6. Unplug water level sensor.
7. Lift pump and sensor out of the machine.
8. Pull up on standpipe to release water.

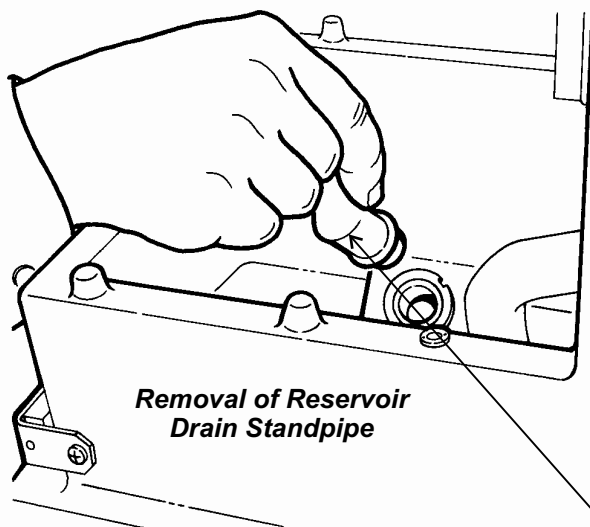

9. Reverse steps 2-8 to reassemble.

Note: Be certain that the float is fully re-seated on the stem and the water pump bracket is positioned properly on the base.

Also be certain that the standpipe is properly seated.

10. Push and release Freeze button.
11. Replace front panel.

To Sanitize the Ice Storage Bin

1. Remove all ice.
2. Remove baffle.
3. Switch ice machine OFF or wait for it to be in a cleaning cycle.
4. Mix a 1 gallon solution of warm (95-115°F.) water and sanitizer. Follow local codes for sanitizer.
5. Wash or spray the entire interior of the ice storage bin with the sanitizer solution. This includes the bottom of the ice machine and the inside of the door, the door gaskets (if any) and door frame.
6. Pour excess sanitizer into the bin to flush the drain system.
7. If the approved sanitizer requires a rinse, rinse all interior surfaces with potable water.

Standpipe

CME506R, 656R, 806R: AutoIQ Cubers

Additional Maintenance: Water Distributors

It may become necessary to remove the water distributors from the top of the evaporator and clean (de-mineralize) them outside of the ice machine.

1. Remove front panel.
2. Push and release the OFF button.

Single Unit Installation:

3. Remove the evaporator covers.
4. Reach over the water distributors and pull the hose off.
5. Push the two water distributors to the right until the left end clears its retaining slot, then pull the left end up.

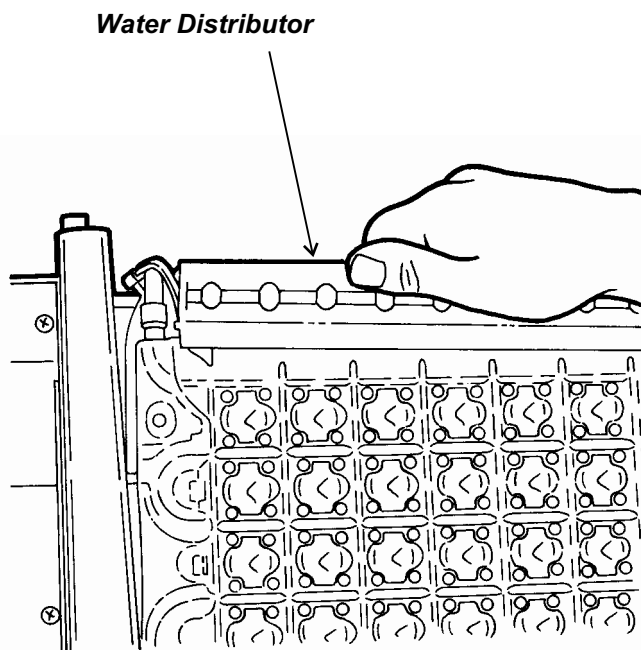

Removal of Water Distributor

6. Repeat for the back evaporator.

7. Examine the top of the evaporators. The Water Distribution Channels must be free from mineral build up. If build up is evident, scrub the channels with Scotsman Ice Machine Cleaner and a plastic bristle brush.

8. Examine the water distributors. Although they are made of a material that is resistant to mineral build up, some may be present. Soak or scrub the distributors in or with a solution of Scotsman Ice Machine Cleaner and warm potable water.

Check That Water Channels Are Clear

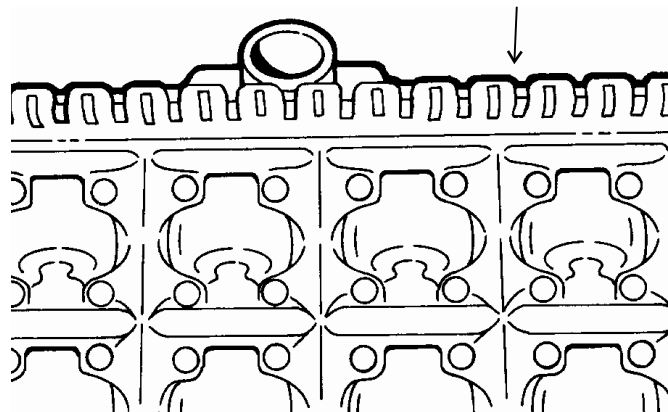

9. Return the water distributors to their normal installed position.

9a. Snap the two distributors onto the water manifold. Place them on the back evaporator, right end first. Push the distributors far enough to the right until the left end clears the retaining slot, then release. Check that the distributors are seated properly.

9b. Place the water hose onto the back water distributors.

9c. Repeat for the front evaporator, if there is one.

10. Push and release the clean button to flush the water system.

11. After the machine stops, push and release the Freeze button.

12. Replace the evaporator cover.

13. Replace the front panel.

CME506R, 656R, 806R: AutoIQ Cubers

Additional Maintenance: Inlet Water Valve Screen

The inlet water valve has a screen on its inlet side to keep debris from flowing into the valve. In some cases, this screen may become clogged or restricted by debris build up. Check for the proper water flow:

Flow rate is 1.25 G.P.M.

1. Remove front panel.
2. Obtain a measuring cup and a watch.
3. Pull the water discharge tube out of the reservoir and place it in the cup.
4. Push and release the Harvest button.
5. If working properly, the water valve will fill an 8 oz cup in about 3-4 seconds. Be prepared to push the Off button. If it does not, the water valve inlet or other water device is restricted.

To Check the Inlet Water Valve Screen.

1. Disconnect the electrical power.
2. Shut off the water supply.
3. Remove the front panel.
4. Unplug the electrical connection of the inlet water valve.
5. Remove the screws holding the inlet water valve to the cabinet.
6. Remove outlet tube from inlet water valve.
7. Rotate inlet water valve from inlet fitting and remove valve from machine.

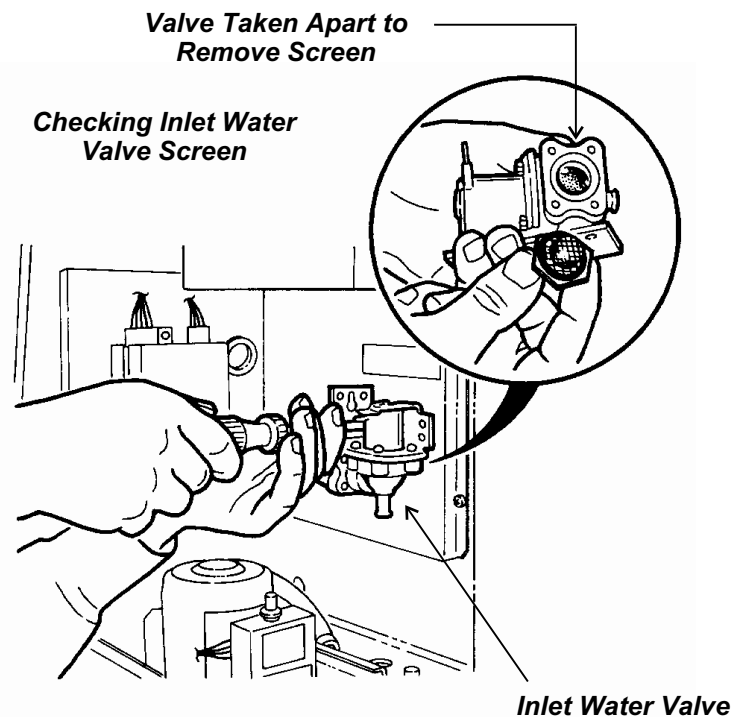

8. Examine the inlet screen, if dirty, brush off screen. Note: Screen is not replaceable, and may only be removed by taking off the covering bracket. The bracket forms part of the inlet water system, and must be water tight to the valve body, removal is not recommended.

9. Reverse to reassemble.

CME506R, 656R, 806R: AutoIQ Cubers

Additional Maintenance: Bin Controls, Condenser

The bin controls use a system of infrared emitting and receiving components to sense the build up of ice in the bin. They are located at the bottom of the ice outlet port. They must be free of mineral build up to function properly. To check:

1. Remove front panel.
2. Push and release the off button.
3. Remove top and right side panels.
4. Remove the evaporator cover.
5. Remove the cube deflector.
6. Push into the freezing compartment the electric eye brackets.

To Clean the Remote Air Cooled Condenser

1. Disconnect and lock out the electrical power.
2. At the remote condenser, check for loose debris on the roof, remove any near the condenser.
3. Check the fan blade and condenser for grease or dust build up. Brush the surface (bottom) of the condenser with a nylon brush to remove surface dirt. Use a fin comb to straighten any bent fins.

Note: Air flow is UP, towards the fan.

If grease is present, use coil cleaner on the condenser. Be sure to wipe up any excess coil cleaner.

4. Reconnect the electrical power.

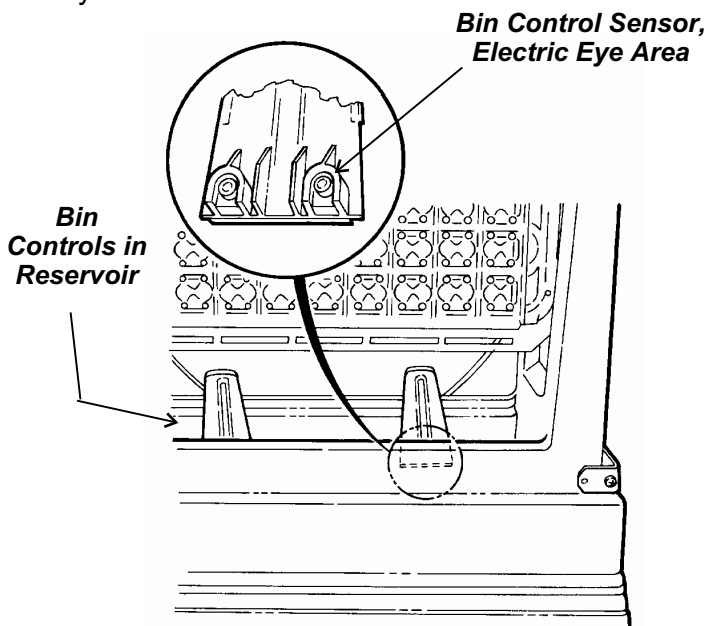

7. Examine the bottom of the brackets, there are two sensors in each bracket, check that they are clear of mineral build up. They may be wiped clean with ice machine cleaner to assist in removal of the build up.

Note: Do NOT use abrasive materials or cleaner on the bin sensor lenses.

CME506R, 656R, 806R: AutoIQ Cubers

Service Diagnosis: Controller Diagnostic Light Analysis

Problem or Symptom	Possible Cause	Probable Correction
Machine is off	Bin is full, ice in cube port	Use some ice
	Power is off, check lights.	If all lights are out, check power supply, restore power if off
	Transformer is open	If all lights are out and there is power, check transformer output for 24 vac
	Unit has been switched off or has finished a Clean cycle, Off light is glowing	Push and release Freeze button
	Unit has Shut Down	Check for Refrigeration or Water Error
Unit is off & Water Diagnostic Light is ON or BLINKING	Water inlet valve malfunction	Check water light, if the light blinks 2 times and repeats, check the water inlet valve for proper water flow.**
	Water pump malfunction	Check that pump hose is attached and if pump is plugged in and working.
	Water level sensor may have failed.	Check float stem, reset machine. If it will not reset or gives another water error and all else is OK, replace the water level sensor.
Unit is off and Refrigeration Diagnostic Light is ON or BLINKING	Low discharge or long freeze cycle	If the refrigeration lite is glowing continuously there is a probable refrigeration problem
	Harvest problem	Check refrigeration light. If the light is blinking steadily, look for a harvest problem.**On controllers 17-1 and higher, this also indicates that cubes were sensed by the bin controls.
		Controllers 17-1 and higher, if the lite blinks 2 times and repeats, check for a harvest error - no cubes sensed.
	High Discharge Temp	Check refrigeration light. If the light blinks 3 times and then repeats, check for a reason for high discharge temperatures - fan motor hot ambient.
	Unit does not go into harvest - exceeds maximum freeze time	Push and release Off button. Push and release Freeze button. Check operation.
		Push cube size float down, check operation.
Exceeds maximum harvest time	Check for cause of long harvest cycle**	
Unit runs and both Error Lights are ON	Temperature sensors out of range	Replace the temperature sensor set (water and discharge).
Same, only 1 light on	Reservoir temp. wrong	Check water temp. and sensor.

* Machine may be reset by pushing and releasing the Off button, then pushing and releasing the Freeze button. ** See following pages

CME506R, 656R, 806R: AutoIQ Cubers

Service Diagnosis

Problem or Symptom	Possible Cause	Probable Correction
Unit is off because of a "Harvest Problem"	Bin controls did not sense ice falling, unit stayed in harvest until the maximum harvest time ran out.	Check bin controls. If the bin full light is on or blinking the bin controls may be dirty. Clean if dirty. The board and bin controls may also need to be checked.
		Push and release Off button. Push and release Freeze button. Check machine operation. Check if ice is made and harvests.
	Bin controls or AutoIQ Controller may have failed.	See "Unit does not shut off" below..
	Other components may have failed	Check the next page
Cubes are too large	Cube size control float is sticking.	Check/clean
	Cube size control adjusted wrong	Re-adjust cube size (if adjustable)
Cubes are too small	Cube size control adjusted wrong	Re-adjust cube size (if adjustable)
	Not enough water	Check for leak in reservoir
Low ice capacity	Dirty condenser	Clean condenser
	Recirculation of air	Block air re-circulation or move condenser
	Low refrigerant charge	Check system. If there is a low charge, find the leak, recover the refrigerant, repair the leak, replace the dryer, evacuate and weigh in the nameplate charge.
	Cube size set wrong	Check standpipe height
Unit does not shut off	Bin control system may have failed.	Check bin controls. Check bin full light, if off, place something between the electric eyes. The bin full light should begin to blink (after 20 seconds of continuous blockage it will glow steadily). If not, check operation of electric eyes by unplugging #4 and jumping out the two pins on the controller (touch the tool to the cabinet to discharge static electricity before contacting the controller). If the bin full light blinks, replace the bin controls. If it does not blink, replace the controller. Note: Leaving #4 unplugged and jumped for 20 seconds will shut the machine down on a bin full (at the end of the harvest cycle). It will restart after 4 minutes or may be reset by pushing the Freeze button.

CME506R, 656R, 806R: AutoIQ Cubers

Service Diagnosis: Components

Problem or Symptom	Possible Cause	Probable Correction
Fan motor does not turn.	Open motor windings, or seized bearings	Replace fan motor
	No power to fan motor	KCMR230 relay points may be open. Wires may be disconnected, contactor may not close.
Pump motor does not turn	Open motor windings, or seized bearings	Replace pump
	No power to pump	Check electrical connections. In Freeze, Clean or Harvest the pump should have power to it. If not, replace the AutoIQ Controller.
Hot Gas Valve does not open.	Open solenoid coil.	Replace hot gas valve
	Stuck valve	Replace hot gas valve
	No power to coil in Harvest	Check wire connections, if ok, replace AutoIQ Controller
Hot Gas Valve leaks thru (warm tube temperatures on both sides of valve during freeze)	Mechanical problem in valve	Replace valve
Water Inlet Valve does not open	Open solenoid coil	Replace valve
	Stuck valve	Replace valve
	No power to valve (early part of harvest)	Check wire connections, if ok, replace AutoIQ Controller
Water Inlet Valve does not flow enough water	Restriction in water supply	Check water filters and/or inlet screen.
Water Inlet Valve leaks thru	Mechanical problem in valve	Replace valve
Compressor does not work	Unit in Clean cycle	Push and release Freeze button.
	Contactor coil open	Replace contactor
	Liquid line valve coil open	Check and replace
	No power to liquid line valve coil	Check wiring and controller
	Pump down control open	Check and replace
	Open starting components	Check and replace
	Open windings	Check and replace compressor
	Internal valve failure	Replace compressor

CME506R, 656R, 806R: AutoIQ Cubers

Service Diagnosis

Problem or Symptom	Possible Cause	Probable Correction
Poor harvest	Hot gas valve does not open	Check for power to the coil, if there is power, replace the hot gas valve
	Head pressure control valve does not maintain enough pressure (in freeze)	Replace the head pressure control valve
Low capacity	High discharge pressure, from a dirty condenser or faulty fan motor	Clean the condenser, repair the fan motor
	Extreme hot location	Relocate the cabinet
	Extremely hot condenser location	Move condenser or provide shade
	Overcharge of refrigerant	Recover, evacuate and weigh in the nameplate charge
	Hot gas valve leaks thru, unit off on refrigeration error	At the end of the freeze cycle, there should be frost on the evaporator end of the hot gas inlet tube. If not, replace the hot gas valve
	Liquid and discharge lines are in contact with each other	Separate and insulate them
Compressor cycles on and off	Low pressure (pump down) control opening and closing	Check the low side pressure, the liquid line valve must open and the low side pressure must rise over 35 PSIG before the pump down control will close to run the compressor.
		Low on refrigerant, locate leak, recover refrigerant, repair leak, replace drier, evacuate and weigh in the nameplate charge.
	Compressor overheats	TXV superheat too high, check charge, if charge is OK, replace TXV
		Mechanical fault with compressor, replace compressor
		Internal relief valve opened, check for cause of high discharge pressure

PTCR Diagnosis

The CME506R, CME656R and CME806R **D Series** all use a PTCR (Positive Temperature Coefficient Resistor) in place of a conventional start relay and start capacitor.

- Power from the contactor connects to the PTCR and to the Run Capacitor.
- A wire connects the other terminal of the PTCR to the compressor's Start winding.
- Another wire connects the run capacitor to the start winding.
- A parallel circuit connects power from the contactor to the Run winding of the compressor.

A PTCR changes resistance sharply when its temperature changes. When the PTCR is cold, it connects full current to the compressor's start winding. After a very short time the PTCR heats up and shuts off the current flow. **Under normal operation, the PTCR's case is at about 180°F.**

At that temperature the PTCR has very high resistance and will not allow current flow. It must cool down to 120°F. before current will pass through it again.

Diagnosis:

1. Disconnect electrical power.
2. Check if the PTCR is cool enough to handle safely. If not, wait 5 minutes for it to cool off.
3. Disconnect both leads to the PTCR and measure its resistance with an ohmmeter. If the PTCR reads less than 22 ohms or more than 40 ohms, replace it.

CME506R, 656R, 806R: AutoIQ Cubers

Operational Characteristics: CME506R

Cycle Times (Minutes):

	0°F. condenser air 70°F. indoor air, 55°F. water	90°F. condenser air 90°F. indoor air, 70°F. water
Freeze	21 - 24	25 - 28
Harvest	1.5 - 2.5	1 - 2

System Pressures (PSIG):

	0°F. condenser air 70°F. indoor air, 55°F. water	90°F. condenser air 90°F. indoor air, 70°F. water
Suction: End of Freeze	34 - 36	36 - 38
Suction: Peak in Harvest	100 - 110	105 - 115
Discharge: 5 minutes into Freeze	230 - 250	250 - 270
Discharge: Minimum in Harvest	200	210

Refrigerant Charge

- 224 ounces of R-404A

Typical Compressor Amps

- Freeze: 10 - 12
- Harvest: 12- 13

Typical Harvest Ice Weight

- 6.5 - 7 lb.

Note: Beginning with CME506R - E series, the refrigeration system uses 2 internally equalized thermostatic expansion valves.

CME506R, 656R, 806R: AutoIQ Cubers

Operational Characteristics: CME656R

Cycle Times (minutes):

	0°F. condenser air 70°F. indoor air, 55°F. water	90°F. condenser air 90°F. indoor air, 70°F. water
Freeze	13 - 15	15 - 17
Harvest	3	1:30

System Pressures (PSIG):

	0°F. condenser air 70°F. indoor air, 55°F. water	90°F. condenser air 90°F. indoor air, 70°F. water
Suction: End of Freeze	24 - 27	27 - 29
Suction: Peak in Harvest	85 - 105	100 - 110
Discharge: 5 minutes into Freeze	240 - 260	265 - 295
Discharge: Minimum in Harvest	190 - 210	225 - 230

Refrigerant Charge

- CME656R uses 232 ounces when connected to ERC201, or 280 ounces when connected to ERC402. All R-404A.

Typical Compressor Amp, single phase

- 9 - 13 freeze
- 13 - 18 harvest

Typical Compressor Amps, three phase

- 6 - 7 freeze
- 9 - 10 harvest

Typical Harvest Ice Weight

- 6.5 - 7 lb.

CME506R, 656R, 806R: AutoIQ Cubers

Operational Characteristics: CME806R

Cycle Times (minutes):

	70°F. condenser air 70°F. indoor air, 50°F. water	90°F. condenser air 90°F. indoor air, 70°F. water
Freeze	10 - 12	11:30 - 13
Harvest	1:45	1:30

System Pressures (PSIG):

	70°F. condenser air 70°F. indoor air, 50°F. water	90°F. condenser air 90°F. indoor air, 70°F. water
Suction: End of Freeze	19 - 21	21 - 23
Suction: Peak in Harvest	100 - 110	115 - 125
Discharge: 5 minutes into Freeze	225	245
Discharge: Minimum in Harvest	180	190

Refrigerant Charge

- CME806R uses 232 ounces when connected to ERC201, or 280 ounces when connected to ERC402. All R-404A.

Typical Compressor Amp, single phase

- Freeze - 13
- Harvest - 14

Typical Harvest Ice Weight

- 6.5 - 7 lb.

Removal and Replacement

Inlet Water Valve

1. Remove the front panel.
2. Shut off the water supply.
3. Push and release the OFF button.
4. Pull the wire harness off the inlet water valve.
5. Remove screws holding the inlet water valve to the cabinet.
6. Pull the valve away from the cabinet and disconnect the outlet tube.

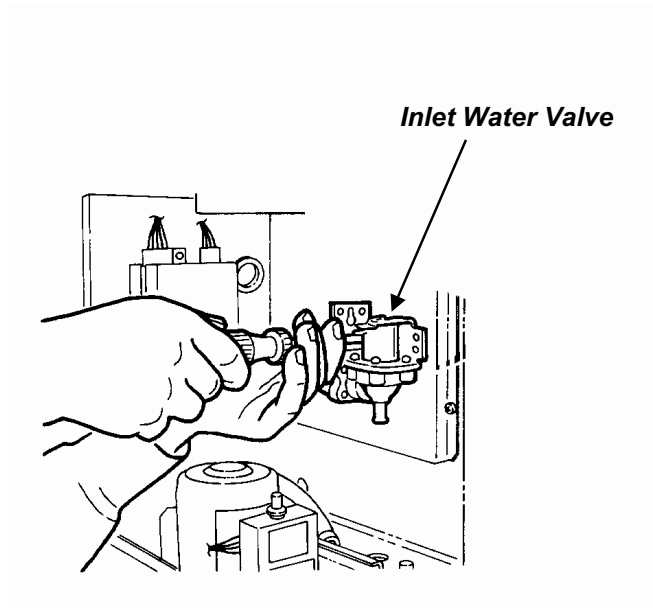

7. Unscrew the water valve from the water inlet tubing. Hold the barbed inlet fitting and rotate the valve.
8. Reverse to reassemble.
9. Push and release the Freeze button.
10. Replace the front panel.

Water Pump

1. Disconnect the electrical power.
2. Remove the front panel.
3. Unplug water pump from its electrical connection.
4. Remove 1 plastic bolt and the reservoir cover.
5. Lift water pump up and disconnect outlet tube.
6. Pull float ball from float stem (it is a snap fit).

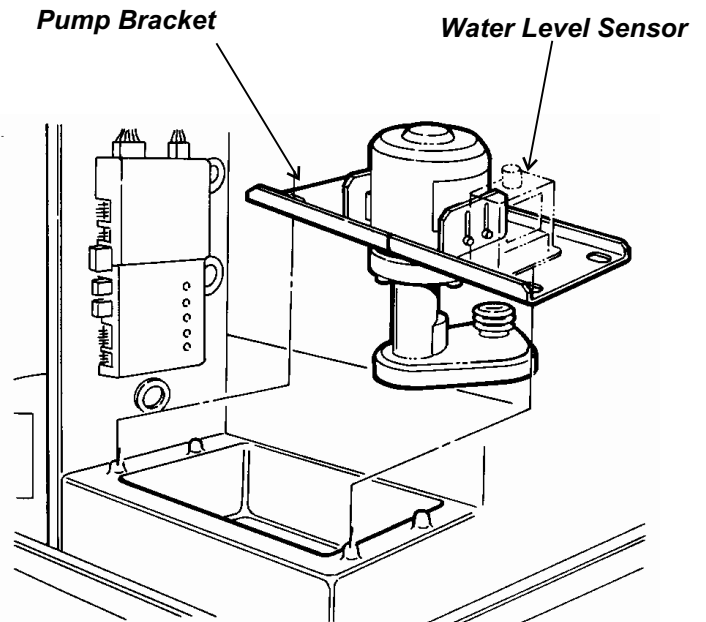

Pull stem out.

7. Locate water level sensor mounting tabs, compress together to release sensor from bracket.
8. Remove water pump brackets from pump.
9. Reverse to replace.
10. Replace front panel.
11. Re-connect electrical power.

CME506R, 656R, 806R: AutoIQ Cubers

Removal and Replacement

Drain Tubing

1. Remove the front panel.
2. Push and release the Off button.
3. Remove bin baffle.
4. Remove 1 plastic bolt and the reservoir cover.
5. Unplug water pump, disconnect ground wire.
6. Unplug water level sensor.

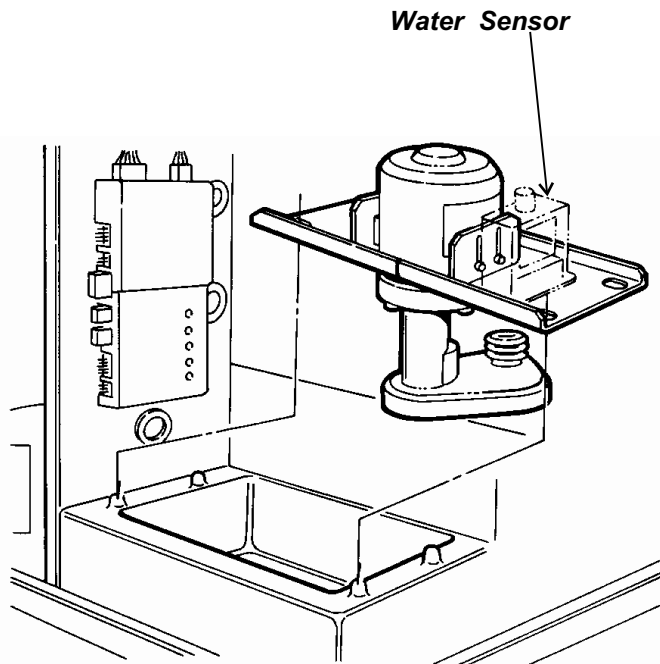

Water Level Sensor/Float Stem

1. Disconnect the electrical power.
 2. Remove the front panel.
 3. Remove 1 plastic bolt and the reservoir cover.
 4. Pull float ball from float stem (it is a snap fit). Pull stem out.
 5. Locate water level sensor mounting tabs, compress together to release sensor from bracket.
 6. Remove harness from sensor.
 7. Reverse to replace.
- Note: Float stem slot opening is 2".
8. Replace front panel.
 9. Re-connect electrical power.

Note: Standpipe height is critical. Measured from the top of the standpipe to the top of the reservoir, the distance should be 2 $\frac{5}{8}$ ". If not, adjust it by rotating the top of the standpipe (it is on threads) to obtain that distance.

7. Lift pump up slightly and pull discharge hose from pump.
8. Remove pump and water level sensor from ice machine.
9. Pull up and forward to remove standpipe.
10. Disconnect back of cabinet drain system.
11. Remove nut on inside of reservoir (where standpipe was).
12. From inside the bin, pull drain tube out of the reservoir and down. Remove from machine.
13. Reverse to reassemble.

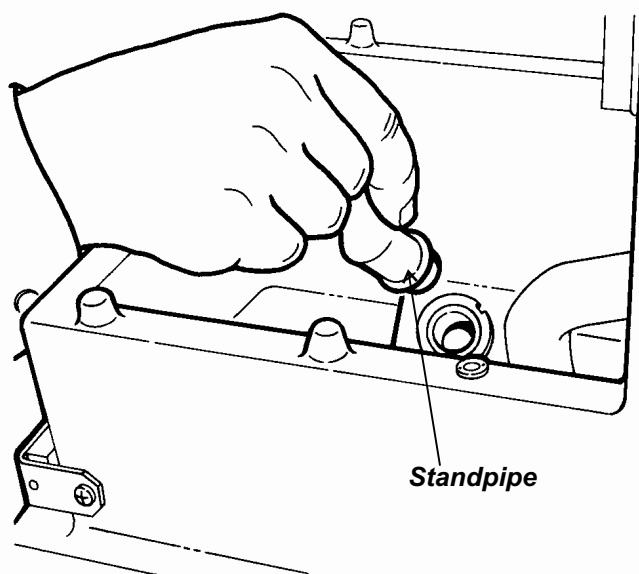

CME506R, 656R, 806R: AutoIQ Cubers

Removal and Replacement: AutoIQ Controller

1. Disconnect the electrical power.
2. Remove the front panel.
3. Remove mounting screw holding controller to cabinet.
4. Touch a metal surface to discharge any static electricity.
5. Pull controller out slightly and unplug all electrical connections.

Note: Do NOT touch the back of the controller.

6. Carefully remove the new controller from its packaging. Again, do NOT touch the back of the controller.

7. Plug all electrical connectors into the new controller.

Electric Eyes (Bin Control)

These must be replaced as a set.

1. Remove front panel.
2. Push and release the Off button.
3. Remove top panel.
4. Remove left and right side panels.
5. Unplug both from the Controller (#3 and #4).
6. Remove evaporator cover.
7. Remove cube deflector.
8. Push in at the wire inlets the bin controls.
9. Pull both into the freezing compartment. Pull wires thru the holes.
10. Remove both bin controls from the freezing compartment.
11. Reverse to reassemble.

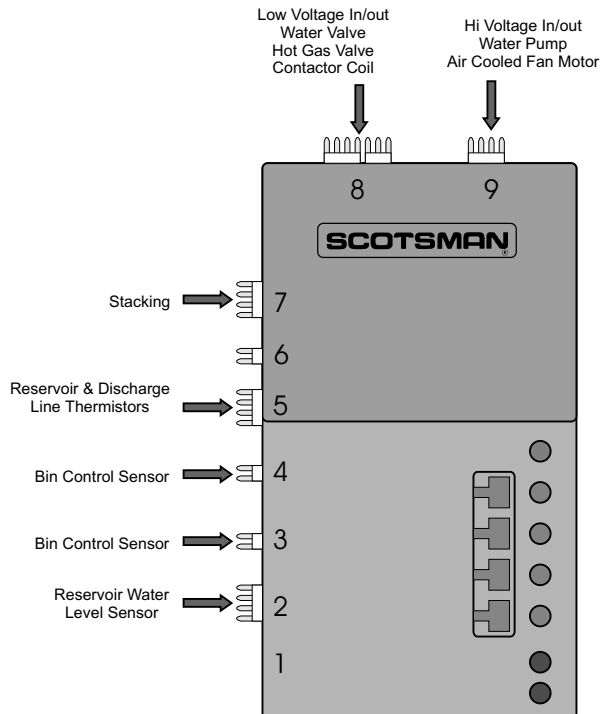

8. Re-attach the controller to the cabinet.
9. Switch on the electrical power. All LEDs should lite up.
10. Push and release the Freeze button.
11. Replace the front panel.

CME506R, 656R, 806R: AutoIQ Cubers

Removal and Replacement: Water Level Sensor

1. Remove front panel.
2. Push and hold the OFF button. Release it when the machine stops.
3. Trace wire harness from water level sensor to the Controller (#2). Unplug the harness from the controller.
4. Lift the pump and mounting plate up enough to remove the float from the stem.
5. Remove two screws holding the sensor to the pump bracket and lift the sensor up and out of the machine.
6. Reverse to reassemble.

Note: Single evaporator models have a different float stem from the double evaporator machines. Do not mix the two. The color of the float stem is supposed to match the color of the reservoir overflow standpipe (the standpipe is also different between single and double evaporator machines).

Discharge Line Temperature Sensor

1. Remove front panel, push and release the Off button.
2. Remove top and left side panels.
3. Locate discharge line sensor. It is attached to the discharge line of the compressor, 6" from the compressor discharge port.
4. Un-snap the clip holding the sensor to the discharge line.
5. Trace the sensor wires back to the controller, they are plugged into #5 with the water temperature sensor, and must be replaced with it.
6. Reverse to replace, be sure that the discharge line sensor is 6" up from the compressor discharge port. The discharge line sensor is marked with yellow tape.

Note: Route wires so they do NOT contact the discharge line.

Water Temperature Sensor

Note: This sensor is replaced as a set with the Discharge Temperature Sensor.

1. Remove front panel.
2. Push and release Off button.
3. Remove 1 plastic bolt and the reservoir cover.
4. Locate water temperature sensor (inserted into pump discharge hose).
5. Pull out to remove.

Water Temperature Sensor

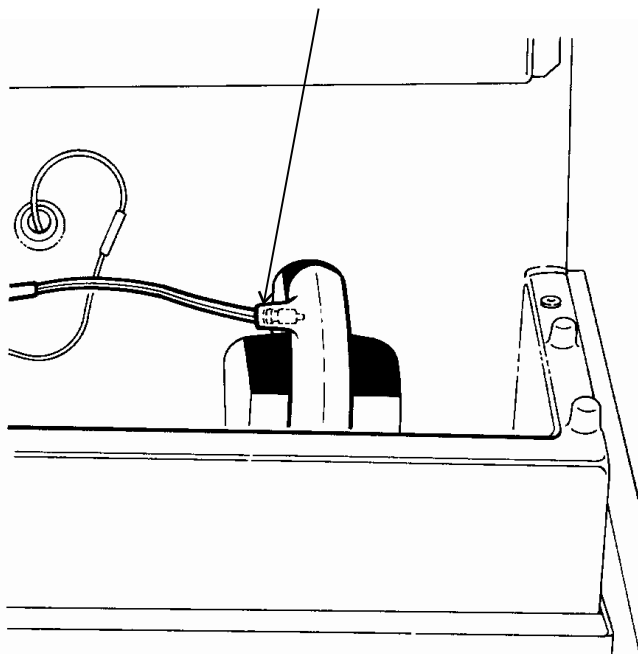

6. Trace back to AutoIQ Controller, unplug from #5.
7. Remove the Discharge Line temperature sensor.

Removal and Replacement:

Transformer and Compressor Starting Components

Single phase compressors use a start relay, start capacitor and run capacitor. All are located in a sheet metal box to the right of the AutoIQ Controller. The compressor contactor is also located in that box.

1. Disconnect electrical power.
2. Remove front panel.
3. Remove 2 screws at the front edge of the metal box, and pull the cover forward and out.
4. To check components, reconnect electrical power.

Note: The contactor coil is 24 volt.

Refrigeration System Components

Due to the expected level of training and experience of a refrigeration mechanic, detailed instructions regarding the replacement of refrigeration components will not be presented. However, critical items will be noted here.

Evaporators

In the unlikely event that an evaporator may need to be replaced, do NOT braze the evaporator joints when the evaporators are seated in the freezing compartment, instead lift them up slightly so that the joints to be brazed are above the top edge of the freezing compartment.

Refrigerant:

This ice machine uses R-404A or HP62 as a refrigerant. It has several unique characteristics.

A. It must use polyol ester refrigerant oil, and that oil is very water absorbent. The system must not be open for more than 15 minutes.

B. An electronic leak detector capable of locating HFC-134a type refrigerant must be used to locate refrigerant leaks.

C. A nitrogen sweep is required when brazing.

D. An HFC type liquid line dryer must be used.

E. When evacuating, use of an electronic micron gage is recommended. Evacuate to 300 microns.

F. It must be liquid charged:

1. Place a drum or cylinder of R-404A on a scale, in the direction to dispense liquid.

2. Attach the charging hose to the cylinder of R-404A. Open the cylinder's valve and purge the hose to the manifold.

3. Close the low side service access valve.

4. Open the discharge side manifold valve and weigh in the name plate charge. After the charge is weighed in, wait a moment and re-check the scale.

5. If all of the refrigerant charge has not been weighed into the discharge side, it must be carefully added thru the low side. Close the discharge service access valve.

6. With a sight glass or charge faster in the hose to the low side port, start the ice machine.

7. Open the low side service access valve.

8. Crack open the low side manifold valve and watch the scale and sight glass. Open and close the low side manifold valve to flow liquid into the manifold but flash off to vapor before it enters the suction side of the refrigeration system.

9. After the scale = the correct charge, shut off the valve on the refrigerant cylinder.

CME506R, 656R, 806R: AutoIQ Cubers

Access Valves:

To use the access valves:

1. Be sure that the valve is closed. Remove the stem cap and insert a 3/16" allen wrench. Check that the valve is closed.
2. Remove the port cap and attach refrigerant manifold hoses.
3. Open the valve and purge the hoses.

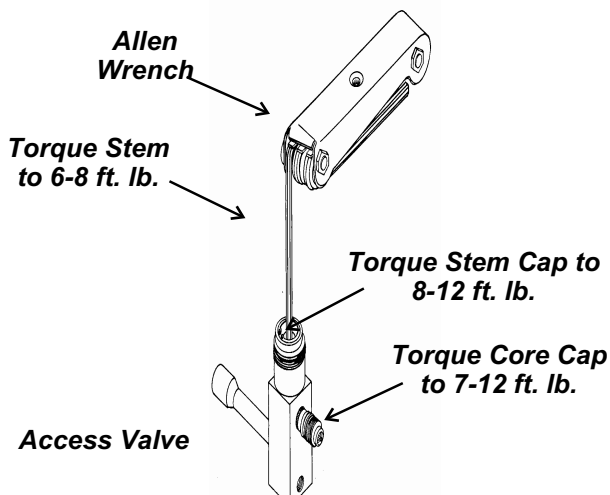

4. When service is complete, shut the discharge access valve first. Then, with the machine running and the middle hose outlet securely fastened to the manifold or refrigerant tank (closed) open both manifold valves. This allows any liquid refrigerant in the discharge hose to flow thru the manifold and into the suction side.
5. After the gages have equaled, shut the manifold valves and the suction access valve.
6. Remove the gages and replace the stem and port caps. Make certain that they are tightly closed.

Liquid Charging

Because R-404A is a near-azeotrope, only liquid refrigerant can be used to recharge the refrigeration system. To do that may take some special techniques:

1. Use an electronic scale to measure the charge.
2. Place a drum or cylinder of R-404A on the scale, valve side up (R-404A disposable cylinders have an internal dip tube and dispense liquid refrigerant from the valve when it is upright).
3. A refrigeration manifold should be attached to the service access valves. Attach the charging hose to the cylinder of R-404A. Open the cylinder's valve and purge the hose to the manifold.
4. Close the low side service access valve.
5. Open the discharge side manifold valve and weigh in the name plate charge. After the charge is weighed in, wait a few minutes and re-check the scale.
6. If all of the refrigerant charge has not been weighed into the discharge side, it must be carefully added thru the low side. Close the discharge service access valve.
7. With a sight glass or charge faster in the hose to the low side port, start the ice machine.
8. Open the low side service access valve.
9. Crack open the low side manifold valve and watch the scale and sight glass. Open and close the low side manifold valve to flow liquid into the manifold but flash off to vapor before it enters the suction side of the refrigeration system. This should only be a few ounces at most.
10. After the scale = the correct charge, shut off the valve on the refrigerant cylinder.
11. With the ice machine running and the discharge access valve closed, open both manifold valves to allow the refrigerant in the hoses to enter the system.
12. Shut the suction service access valve.
13. Remove the refrigeration manifold gages.
14. Replace and tighten all caps.

Before Calling for Service

Check the following:

1. Has the water supply to the ice machine or building been shut off? If it has, the ice machine will automatically restart within 25 minutes after water begins to flow to it.
2. Has power been shut off to the ice machine? If yes, the ice machine will automatically restart when power is restored.
3. Has power been shut off to the remote condenser, if it's not powered by the ice machine? If yes, reconnect power and reset the ice machine.

To Manually Reset the machine:

1. Remove the front panel.
2. Locate the AutoIQ Controller. If a red diagnostic light is glowing, note which one and its blink rate. Then push and release the off button.
3. Push and release the Freeze button.
4. The machine should begin to operate. If there is a lack of water it will shut off again soon.
5. Return the front panel to its normal position.

If the machine shuts down again, call for service.

To Shut the Machine Off:

1. Remove the front panel.
2. Locate the controller.
3. Push and hold the Off button for 3 seconds or until the machine stops.

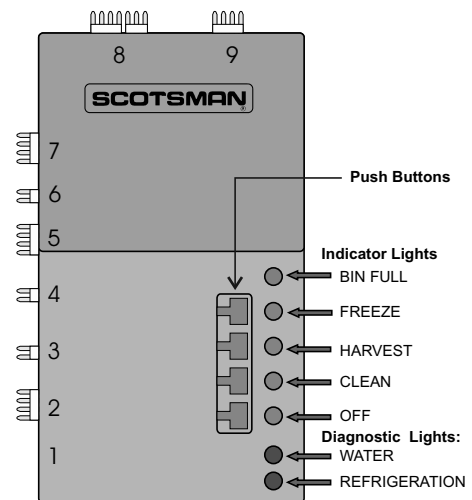

In Place Cleaning of the Ice Machine Water System:

1. Remove all ice from the bin. Either save it in a sanitary container or discard it. If the cleaning was planned, the ice machine could be switched off the night before to minimize waste.
2. Remove the front panel.
3. Push and release the Harvest button (this releases any ice that may be on the evaporators and warms them up).
4. Wait for the machine to finish the Harvest cycle (the machine will stop).
5. Remove the cube deflector, the evaporator cover, the cascading shield (if used) and the bin control sensors. Place the cascading shield and the cube deflector in a separate container. Place the bin controls in the reservoir.
6. Push and release the Clean button. The Clean indicator light will be blinking, and the pump will restart.
7. Pour 12 ounces of Scotsman Ice Machine Cleaner into the reservoir water. Return the evaporator cover to its normal position.
8. Mix a solution of 8 ounces of Scotsman ice machine cleaner and 1 gallon of warm (95-115°F.) water. Use the solution to scrub the cascading shield and cube deflector in the separate container.
9. After the ice machine cleaner has circulated for 10 minutes, push and release the Clean button. This starts the rinsing process. The Clean indicator light will be ON. Note: The rinse process flushes any residual cleaner out of the ice machine's water system.
10. Continue the rinsing process for 20 minutes, then push the off button to switch the machine off.

11. Go to the next step to sanitize the machine or go to step 19 to finish the cleaning process.

12. Mix 2 gallons of Sanitizer solution. Follow local codes for Sanitizer.

Note: A possible sanitizing solution may be made by mixing 1 ounce of liquid household bleach with 2 gallons of warm (95-115°F.) potable water.

13. Push and release the Clean button again.

14. Pour 16 ounces of Sanitizer solution into the reservoir water.

15. After the solution has circulated for 10 minutes push and release the Clean button. This starts the rinse process. Sanitize the ice storage bin while waiting.

16. Continue the rinsing process for 20 minutes, then push the off button to switch the machine off.

17. Remove the evaporator cover and spray or wash all interior surfaces of the freezing compartment including the evaporator cover with sanitizer solution.

18. Thoroughly immerse the cascading shield and cube deflector in the sanitizing solution.

19. Return the bin controls, cascading shield and cube deflector to their original positions.

20. Return the evaporator cover to its original position. Push and release the Freeze button.

21. Return the front panel to its normal position and secure it to the machine with the original screws.

17-2244-01 Rev. C.