

C

A

V

Evaporator/Freezing Chamber

Pump/Drain Tubes

Storage Bin

Water Pump

Compressor

Control Box

Heat Exchanger

Panels and Liner

Wiring Diagrams

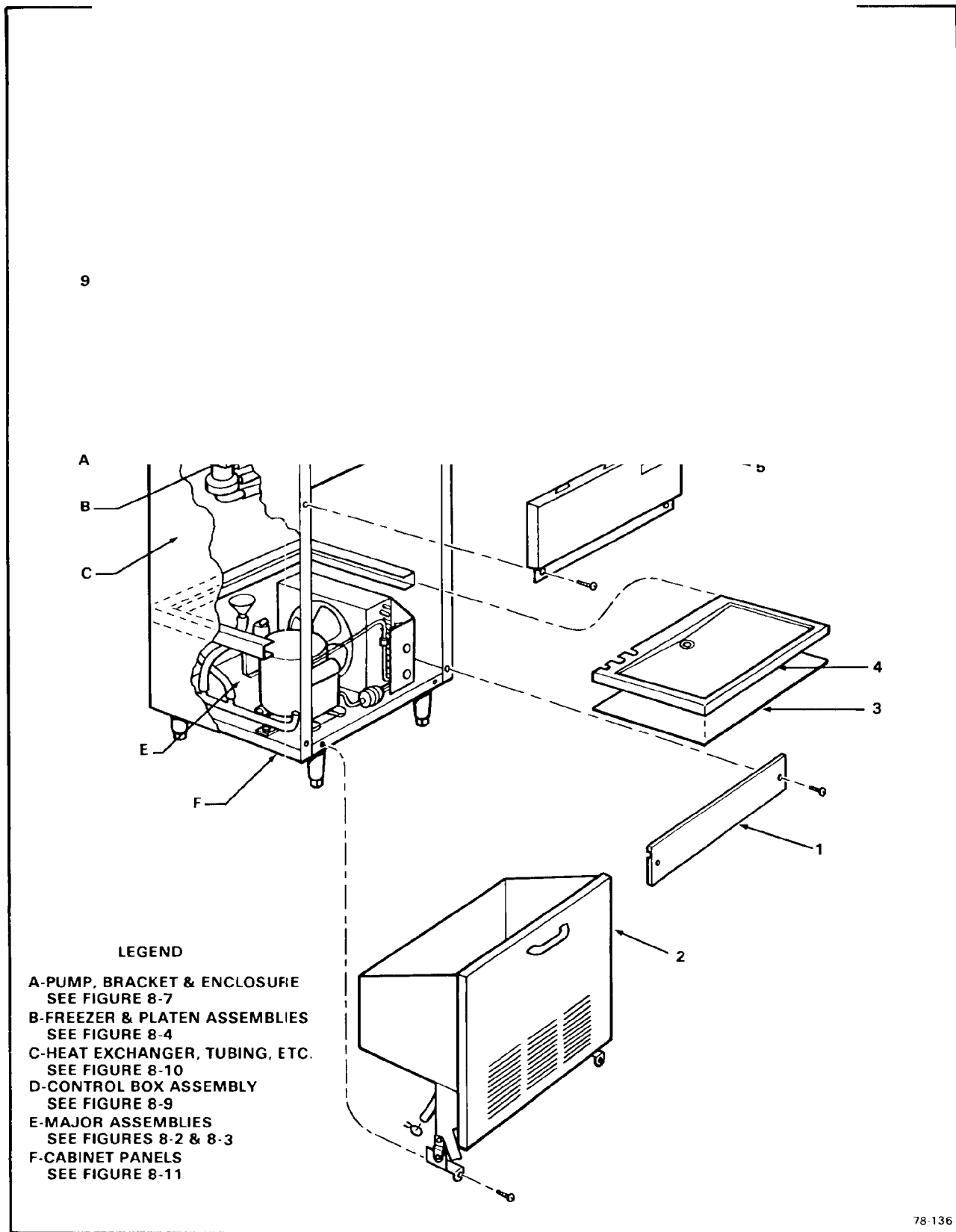

Figure 8-1. AC-20 Cabinet.

INDEX NO.			EQ'D MBER
			1
1			1
			1
			2
2			1
	Door/Bin Assembly, Lower Front (Stainless Steel)	A25717-002	1
	Attaching parts, Index 2		
	Clamp, Hose 13/16-inch O.D.	02-1338-00	1
	Screw, No. 1/4-20 x 1/2 T/C Hex Hd	03-0571-00	2

3	Retainer, Heat - Bottom	A25804-001	1

4	Retainer, Heat - Foamed	02-2237-01	1

5	Door Assembly, Upper Front (C.R.S Painted)	A25709-001	1
	Door Assembly, Upper Front (Stainless Steel)	A25709-002	1
	attaching parts, Index 5		
	Screw, No. 8 x 1/2 T/F Tap	03-1404-10	2

6	Panel, Top (C.R.S. Painted)	A25704-001	1
	Panel, Top (Stainless Steel)	A25704-002	1
	attaching parts, Index 6		
	Screw, No. 8 x 1-1/4 S/T Flat Hd	03-1419-09	4

INDEX NO.	REQ'D NUMBER
7	1 1 1
8	1
9	1
Screw, No. 8 x 1/2 T/F Tap * * *	03-1404-10 3

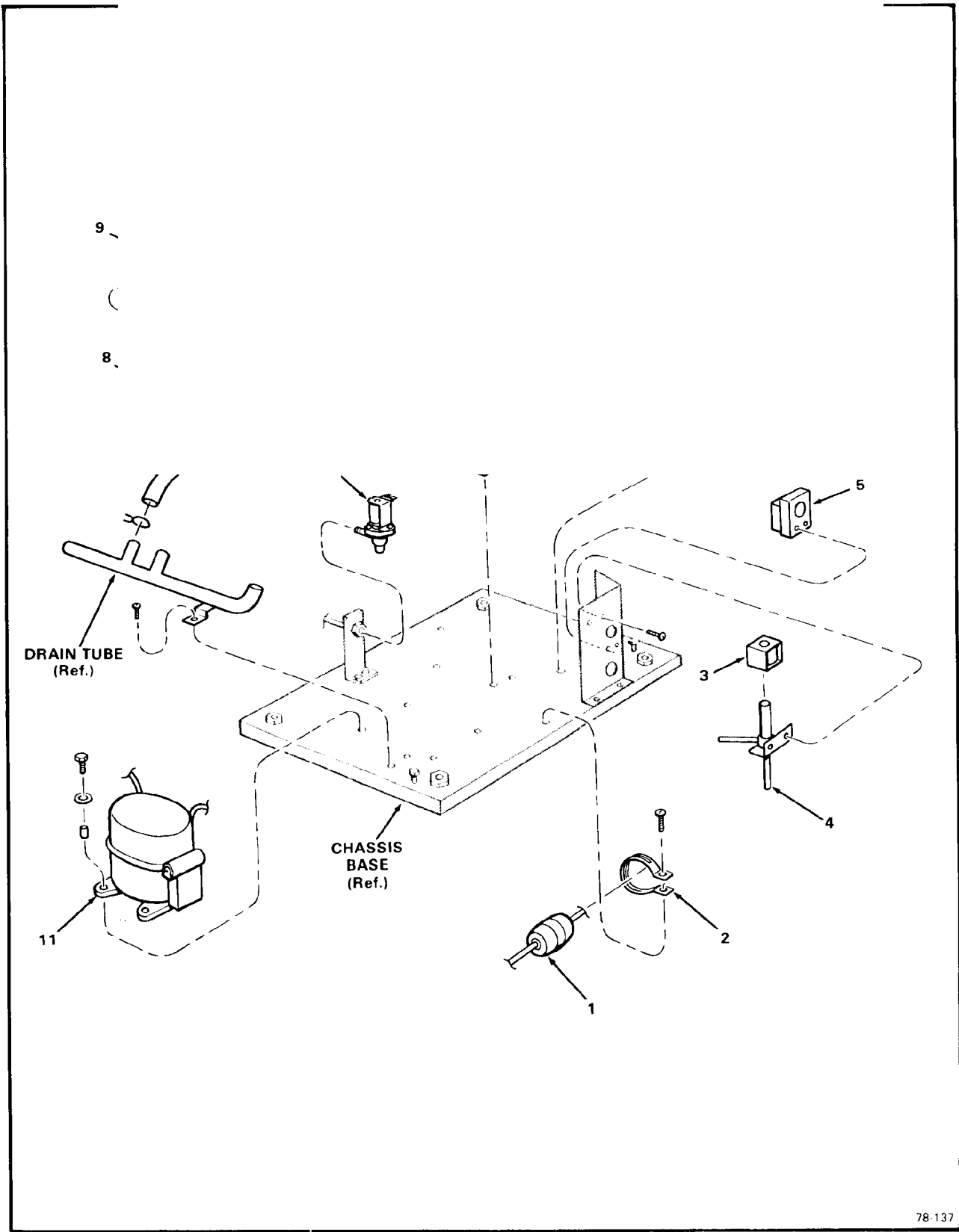

78-137

Figure 8-2. Major Assemblies - Air-Cooled.

INDEX NO.			REQ'D NUMBER
			Ref.
1			1
2			1
			1
3			1
4			1
	Screw, No. 8-32 x 3/8 Pan Hd	03-1403-17	2

5	Control, Hi Pressure	11-0394-01	1
	attaching part, Index 5		
	Screw, No. 8 x 1/2 T/F Tap	03-1404-09	2

6	Bracket Assembly, Fan Motor & Mounting	No Number	1
6a	Blade, Fan	18-0420-00	1
	Pad, Vibration (p/o Fan Motor)	No Number	1
	Nut, Fan Mounting (p/o Fan Blade)	No Number	1
6b	Bracket, Fan Mounting	18-3705-01	1
6c	Motor, Fan	12-1575-01	1
	attaching parts, Index 6c to 6b		
	Screw (p/o Fan Motor)	No Number	4
	attaching parts, Index 6b to Chassis Base		
	Lockwasher, No. 1/4 Internal Tooth - Carbon Steel Zinc Plated	03-1417-08	2
	Screw, No. 1/4-20 x 1/2 T/C Hex Hd	03-0571-00	2

INDEX NO.			EQ'D NUMBER
7			1
			2
8			1
9			1
			2
			2
10	Valve, Water Inlet * * *	12-1900-05	1
11	Compressor (See Figure 8-8) attaching parts, Index 11 Grommet Sleeve, Mounting Washer, No. 5/16 Plain Screw, No. 5/16-18 x 1-1/2 Hex Cap * * *	No Number 18-2200-28 18-2200-27 03-1407-07 03-1405-20	1 4 4 4 4

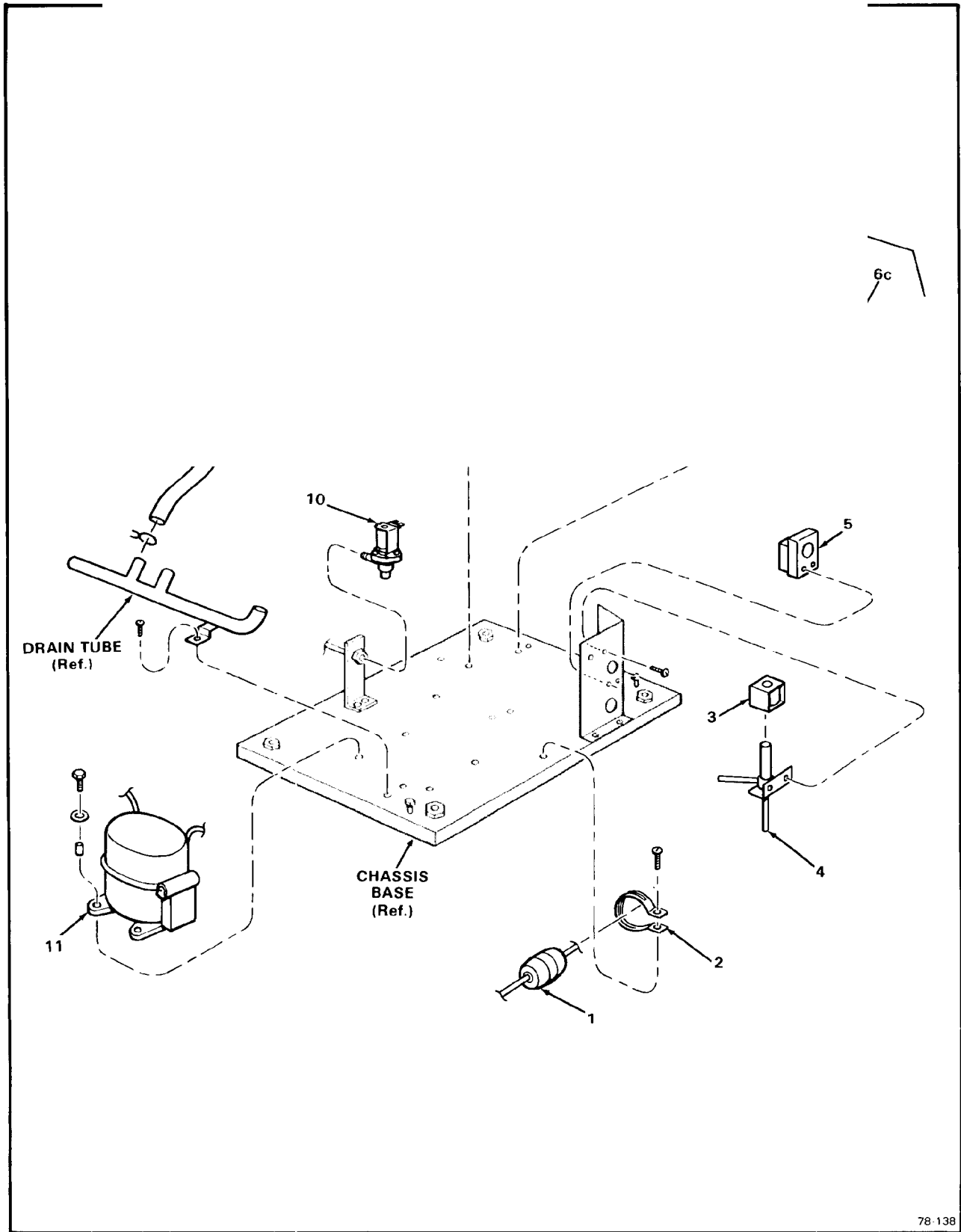

78-138

Figure 8-3. Major Assemblies - Water-Cooled.

INDEX NO.			EQ'D MBER
			Ref
1			1
2			1
			1
3			1
4			1
			2

5	Control, Hi Pressure (Flare Nut Connector)	11-0388-01	1
	Control, Hi Pressure (Solder Connector)	11-0388-02	1
	attaching part, Index 5		
	Screw, No. 8 x 1/2 T/F Tap	03-1404-09	2

6	Regulator Assembly, Water	No Number	1
	attaching parts, Index 6		
	Lockwasher, No. 1/4 External Tooth - Carbon Steel Zinc Plated	03-1417-09	2
	Screw, No. 1/4-20 x 1/2 T/C Hex Hd	03-0571-00	2
6a	Union, Half - No. 5/8-18 x 3/8 Flare	16-0677-01	1
6b	Nipple Assembly, Pipe (w/Bracket)	A15924-000	1
6c	Coupling - 3/8 NPT x 3/8 Flare Brass	16-0355-00	1
6d	Valve, Water Regulator	11-0198-02	1

7	Condenser - Water-cooled	18-3707-01	1
	attaching parts, Index 7		
	Screw, No. 1/4-20 x 1/2 T/C Hex Hd	03-0571-00	2

8	Tube - 1/2-inch I.D. x 12-1/4 (Order per foot)	13-0674-04	1

INDEX NO.			REQ'D NUMBER
9			1
			2
			2
10			1
11			1
	Sleeve, Mounting	18-2200-27	4
	Washer, No. 5/16 Plain	03-1407-07	4
	Screw, No. 5/16-18 x 1-1/2 Hex Cap	03-1405-20	4
	* * *		

INDEX NO.			REQ'D NUMBER
			Ref.
1			1
2			1
			4
3			4
	attaching parts, Index 3		
	Screw, No. 8 x 1/2 T/F Tap S/S (Curtain screws)	03-1404-10	Ref.

4	Spinner, Jet (3 per spray tube)	A09543-000	3 (12)

5	Tube, Manifold	02-2193-01	1

6	Chute, Cube - Rear	A25747-001	1

7	Platen Assembly (medium size ice cubes)	A25748-020	1
	Platen Assembly (small size ice cubes)	A25753-020	1

8	Chamber, Freezing	02-2226-01	1

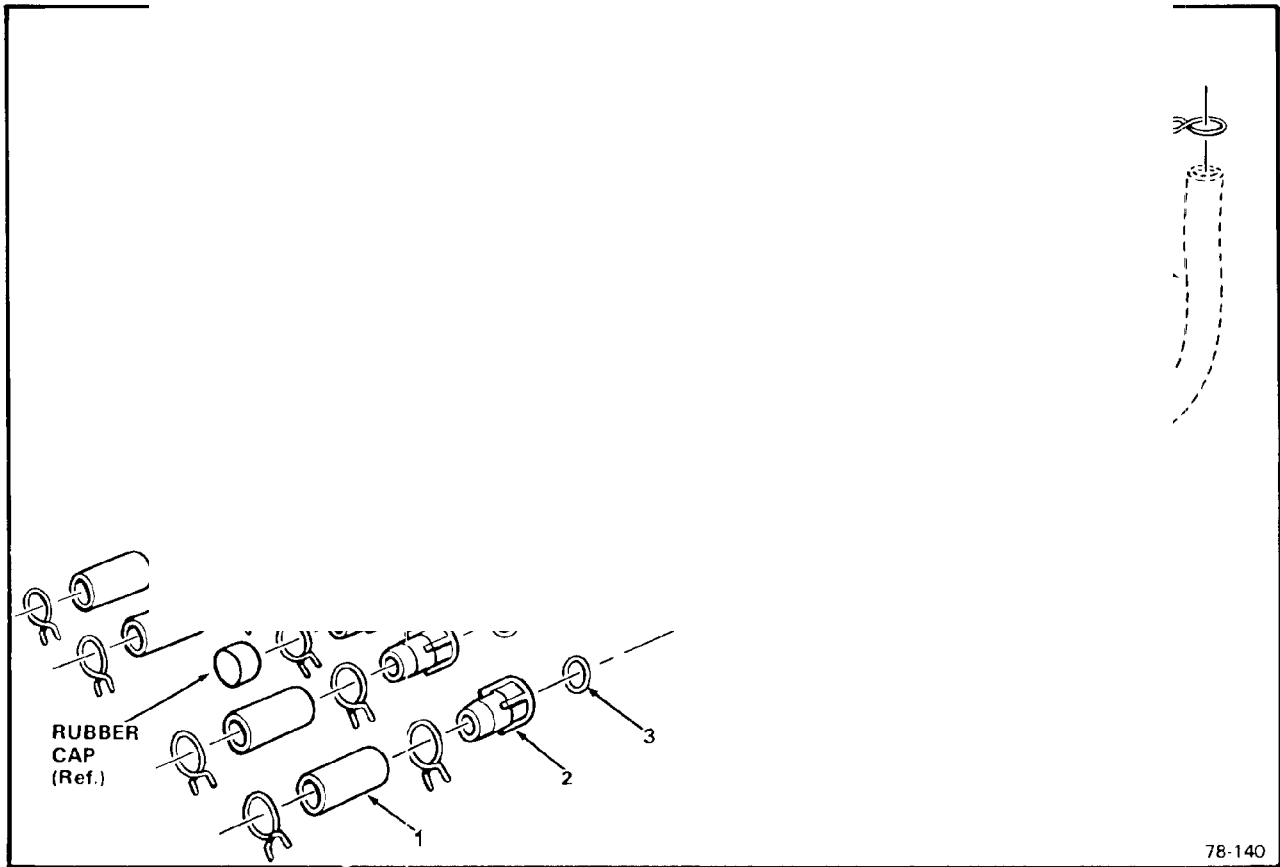

Figure 8-5. Freezer-Pump-Drain Tube Connections.

INDEX NO.	DESCRIPTION	PART NUMBER	REQ'D NUMBER
	Freezer-Pump-Drain Tube Connections (See Figure 8-4 for next higher Assembly)	No Number	Ref.
1	*** Tube - 3/4-inch I.D. x 2 (Order per foot)	13-0674-07	4
2	Tube, Female attaching parts, Index 1 & 2 Clamp, Hose Clamp, Hose (Fits over Rubber Cap)	A24379-001 02-1358-01 02-1530-01	5 8 1
3	*** O-Ring	13-0617-02	5
4	*** Tube, Male	02-2080-01	3
5	*** Tube, Pump Pick Up	02-2082-01	1
6	*** Pipe, Stand ***	02-2125-01	1

S
(ONLY)

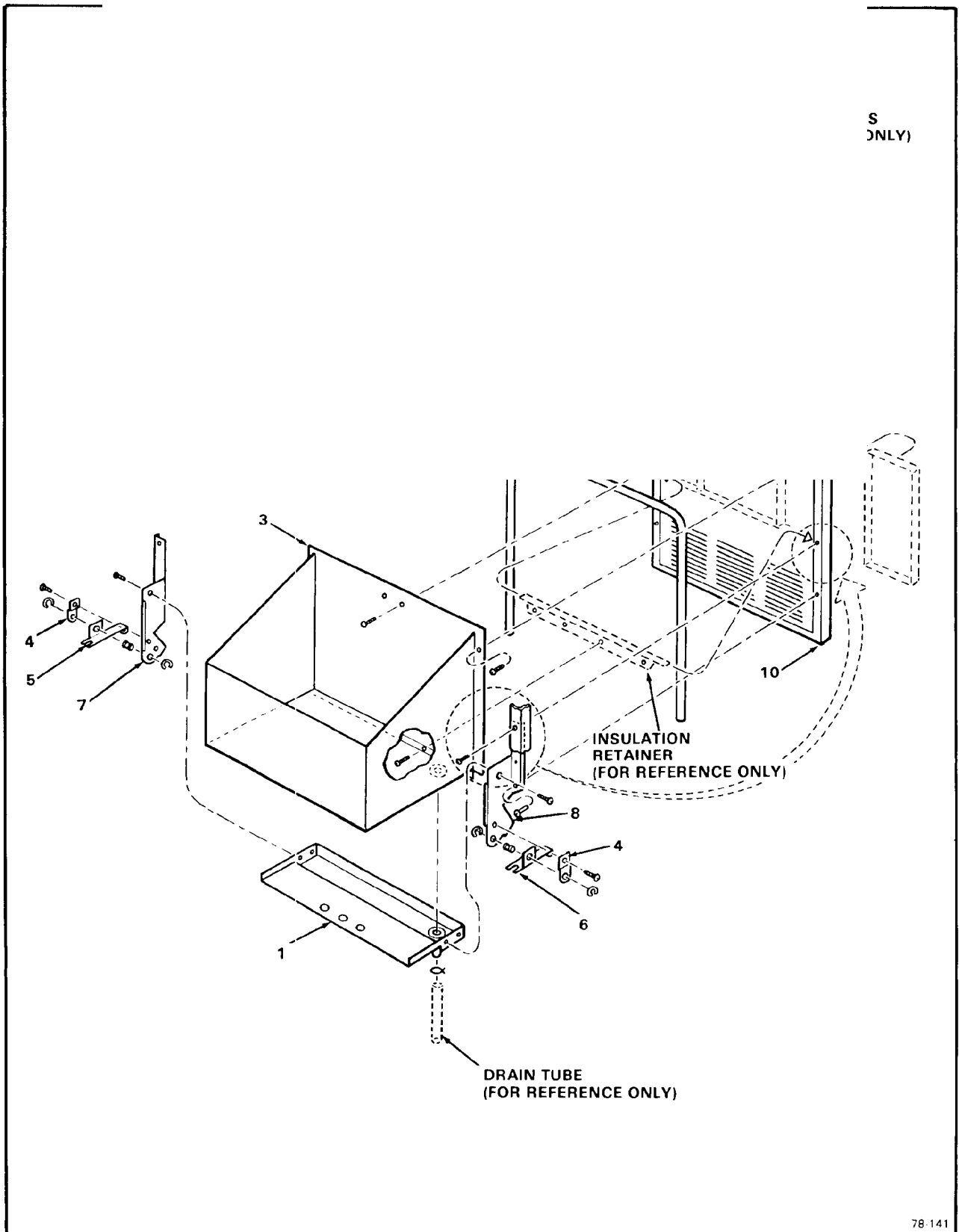

Figure 8-6. Lower Front Door Bin Assembly.

INDEX NO.			EQ'D MBER
			Ref.
			Ref.
1			1
			4
2			1
	Screw, No. 10-24 x 1-1/4 Pan Head	03-1403-73	2

3	Bin Assembly	A25729-001	1
	attaching part, Index 3 (sides of Bin)		
	Screw, No. 8 x 1/2 T/F Tap	03-1404-10	16
	attaching part, (bottom Bin to Insulation Retainer)		
	Screw, No. 8 x 1/4 T/F Tap	03-1404-29	4

4	Bracket, hinge	A25720-001	2
	attaching part, Index 4 to 7 & 8		
	Screw, No. 1/4-20 x 1/2 T/C Hex Hd	03-0571-00	2

5	Hinge, Base - Right	A25719-002	1
6	Hinge, Base - Left	A25719-001	1
7	Hinge, Right Side	A25724-002	2
8	Hinge, Left Side	A25724-001	
	Attaching parts, Index 4, 5, 6 to 7 & 8		
	Pin Hinge	A25722-001	2
	Ring, Retaining	03-1539-08	4
	attaching parts, Index 7 & 8 to 1 & 10		

INDEX NO.
9
10

REQ'D NUMBER
(ref.)
1
1
1

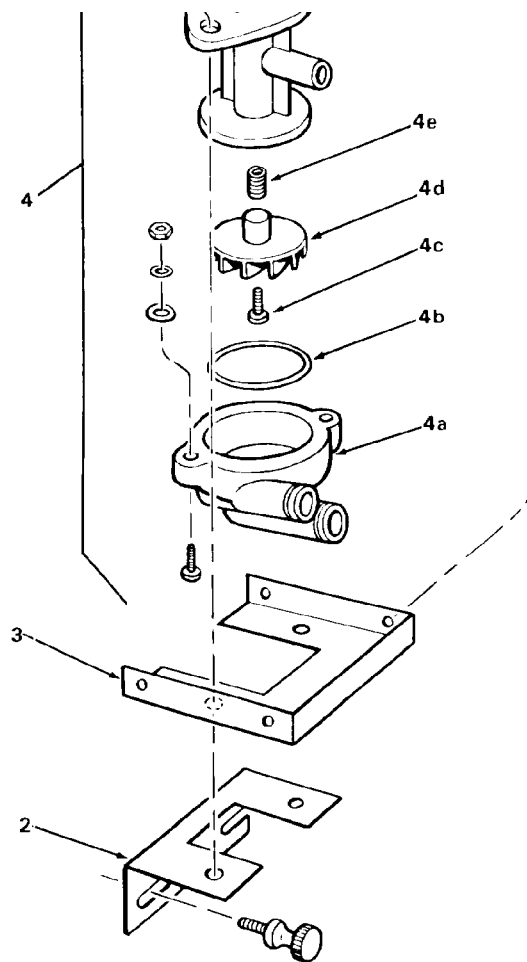

78-142

Figure 8-7. Water Pump, Bracket & Enclosure Assembly.

INDEX NO.			EQ'D MBER
			Ref.
1			1
			4
2			Ref.
3	Bracket, Pump Box	A25794-001	1
	attaching parts, Index 2, 3 & 4		
	Screw, No. 1/4-20 x 1/2 T/X Hex Hd	03-0571-00	2
	attaching part, (Pump & Bracket to Cabinet Liner)		
	Screw, Thumb - No. 10-24 x 1/2 Knurled Hd	03-0727-00	2

4	Pump, Water	12-1975-01	1
	attaching part, Index 4 to 2 & 3		
	Screw, No. 1/4-20 x 1/2 T/C Hex Hd	03-0571-00	Ref.
4a	Housing, Pump Intake	12-1849-61	1
4b	O-Ring	12-1849-60	1
4c	Screw	12-2061-54	1
4d	Impeller	12-2061-53	1
4e	Spring	12-2061-55	1
	attaching parts, Index 4a thru 4e		
	Washer, No. 6 Plain S/S	03-1407-01	2
	Lockwasher, No. 6 External Tooth-Phosphor Bronze	03-1417-01	2
	Screw, No. 6-32 x 7/8 Phil Recess Pan Hd	03-1403-08	2
	Nut, No. 6-32	03-1406-01	2
4f	Blade, Fan	02-1719-00	1

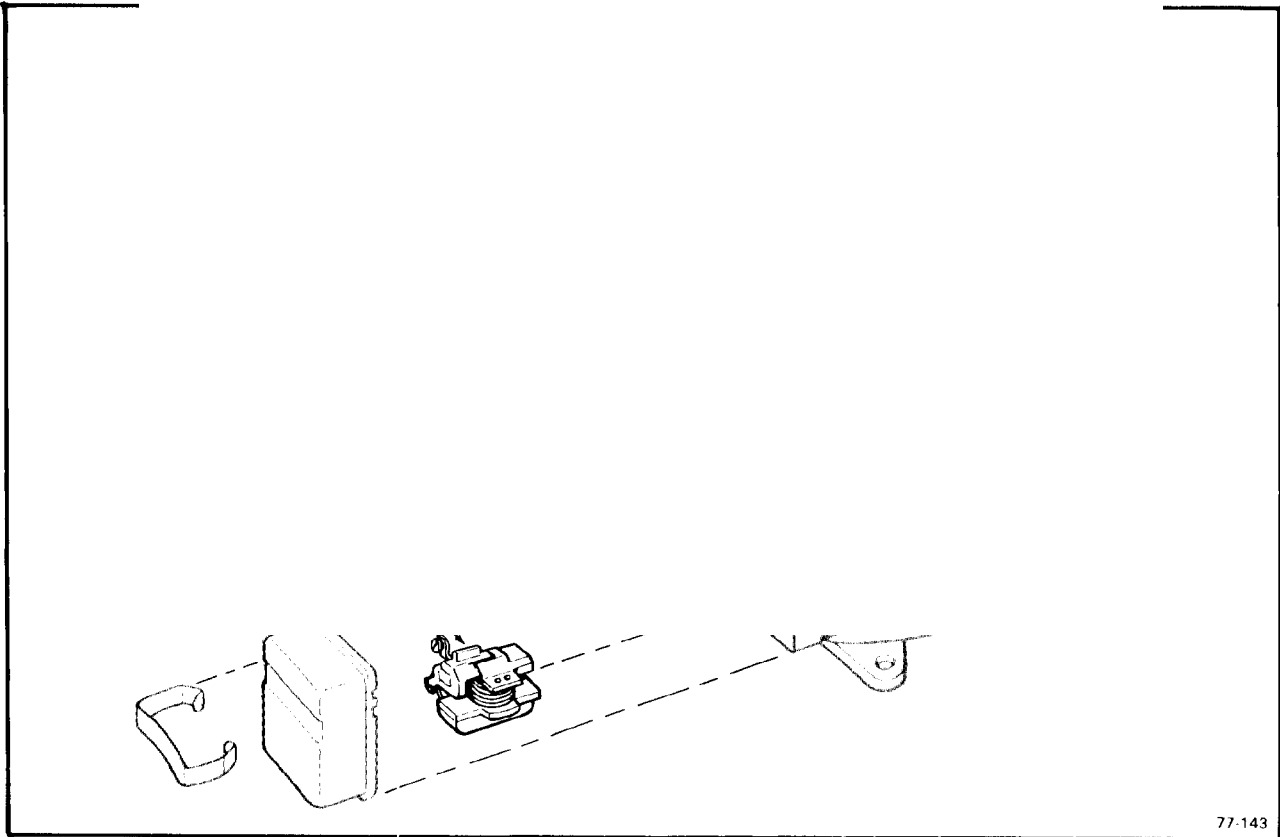

77-143

Figure 8-8. Compressor Assembly.

INDEX NO.	DESCRIPTION	PART NUMBER	REQ'D NUMBER
	Compressor Assembly (Copeland)	18-4100-01	Ref.
	(See Figure 8-2/11 and 8-3/11 (Tecumseh)	18-3600-01	Ref.
	for next higher Assembly)		

1	Capacitor, Start (Copeland)	18-4100-43	1
	Capacitor, Start (Tecumseh)	18-3600-30	1

2	Relay (Copeland)	18-4100-42	1
	Relay (Tecumseh)	18-3600-34	1

3	Overload (Copeland)	18-4100-41	1
	Protector (Tecumseh)	18-3600-35	1

NOT
1. E
i
0
0
2. 0
0
3. 0

ing
nits

tive
ts.

the

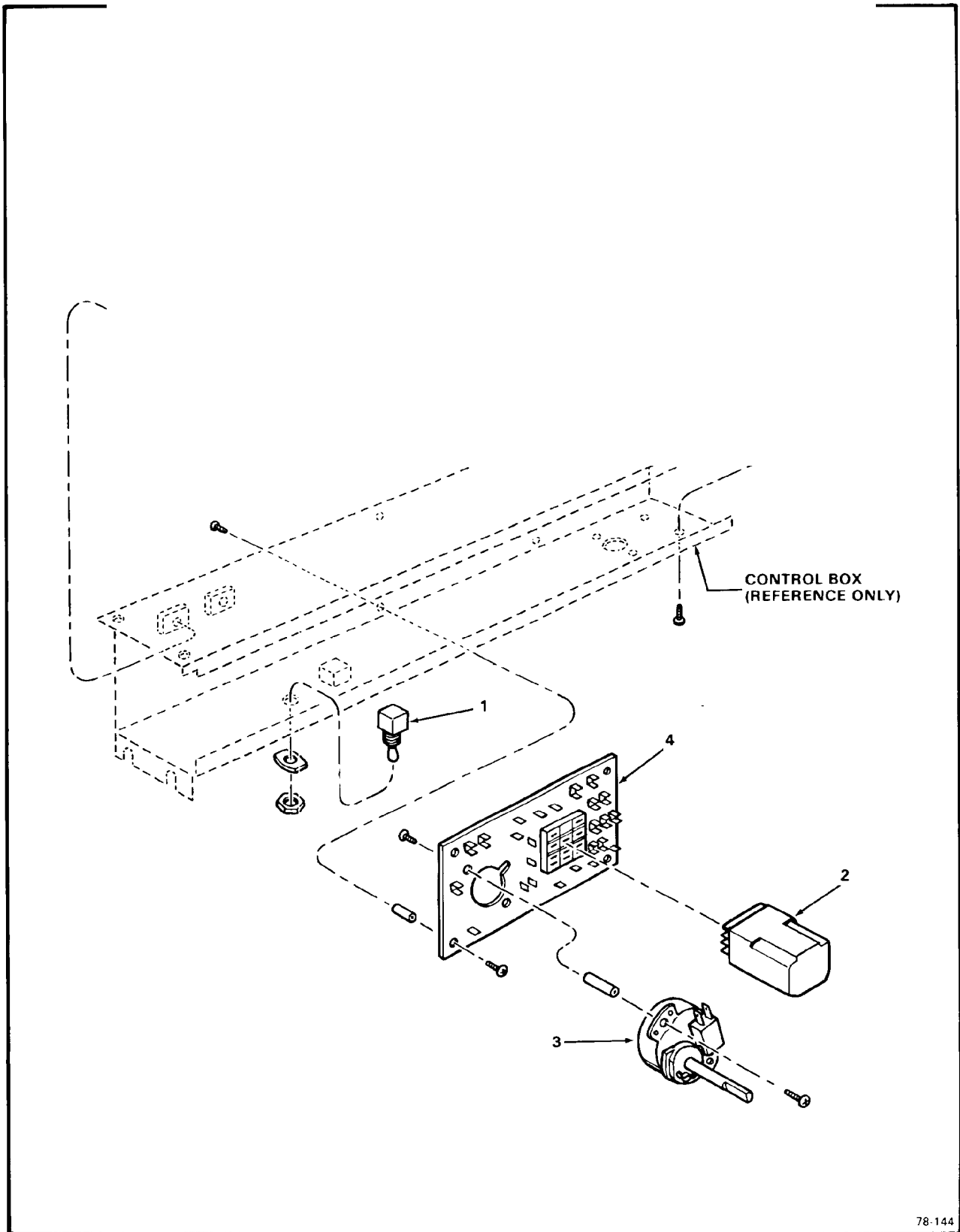

78-144

Figure 8-9. Control Box Assembly.

INDEX NO.			EQ'D IMBER
			Ref.
1			1
2			1
			1
3			1
	attaching parts, Index 3		
	Stand - Off - (7/8 lg.)	02-2242-01	2
	Screw, No. 6-32 x 1/4 Phil Recess Pan Hd	03-1403-02	4

4	Board Assembly, Circuit	12-1912-01	1
	attaching parts, Index 4		
	Stand - Off - (5/8 lg)	02-2242-02	5
	Screw, No. 6-32 x 1/4 Phil Recess Pan Hd	03-1403-02	5

5	Contactator	12-2041-01	1
	attaching parts, Index 5		
	Screw, No. 8-32 x 3/16 Phil Recess Pan Hd	03-1403-14	2

6	Control, Temperature (Bin)	11-0353-02	1
7	Control, Cube Size	11-0345-02	1
	Screw, No. 8-32 x 1/4 Phil Recess Pan Hd	03-1403-15	4

8	Grommet	13-0557-00	2

TEN
SEMBLY
(Ref.)

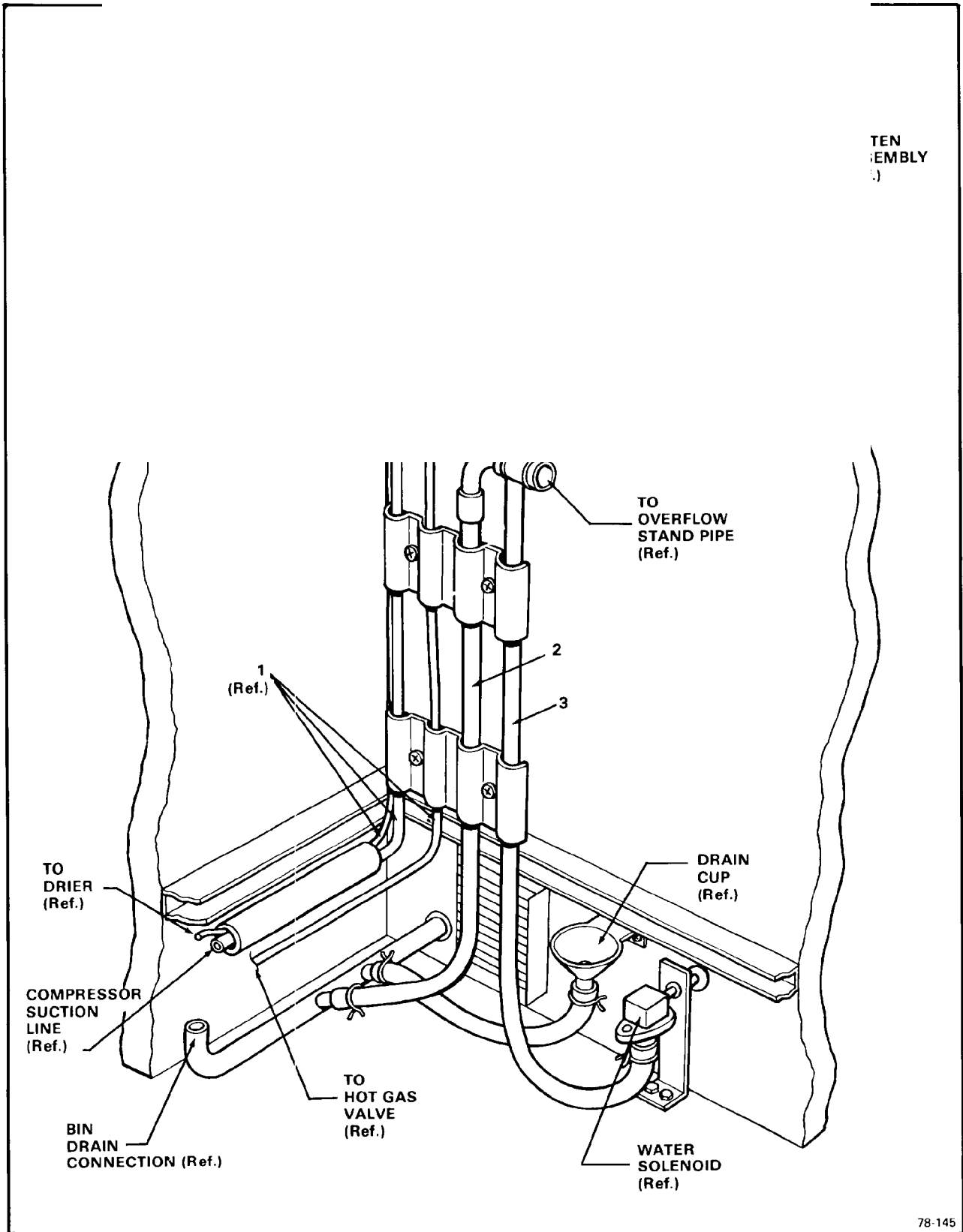

78-145

Figure 8-10. Heat Exchanger, Tubing & Fittings.

INDEX NO.			EQ'D MBER
			Ref.
1			1
2			1
3			1
			2
	* * *		2

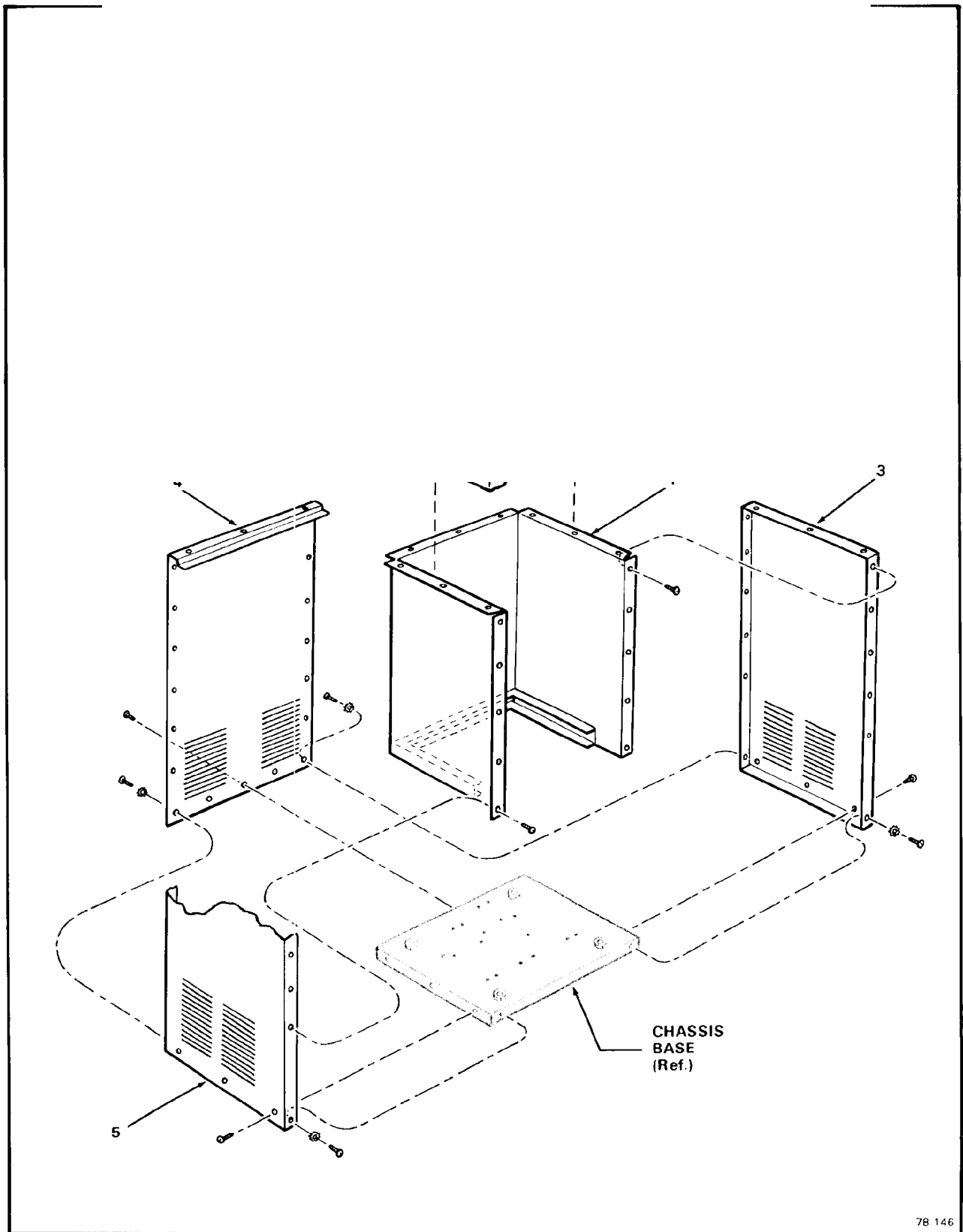

78 146

Figure 8-11. Panels and Cabinet Liner Assembly.

INDEX NO.			Q'D MBER
			Ref.
1			1
			6
2			1
3			1
	Panel, Right Side (Stainless Steel)	A25703-002	1
	attaching parts, Index 3		
	Lockwasher, No. 8 External Tooth-Carbon Steel Zinc Plated	03-1417-03	2
	Screw, No. 8 x 1/2 T/F Tap	03-1404-10	4
	* * *		
4	Panel, Back (C.R.S. Painted)	A25707-001	1
	Panel, Back (Stainless Steel)	A25707-002	1
	attaching parts, Index 4		
	Lockwasher, No. 8 External Tooth-Carbon Steel Zinc Plated	03-1417-03	Ref.
	Screw, No. 8 x 1/2 T/F Tap	03-1404-10	17
	* * *		
5	Panel, Left Side (C.R.S. Painted)	A25702-001	1
	Panel, Left Side (Stainless Steel)	A25702-002	1
	attaching parts, Index 5		
	Lockwasher, No. 8 External Tooth-Carbon Steel Zinc Plated	03-1417-03	2
	Screw, No. 8 x 1/2 T/F Tap	03-1404-10	4
	* * *		

CAUTION: MORE THAN ONE DISCONNECT MAY BE REQUIRED TO DISCONNECT ALL POWER TO THIS UNIT.

THIS UNIT MUST BE GROUNDED

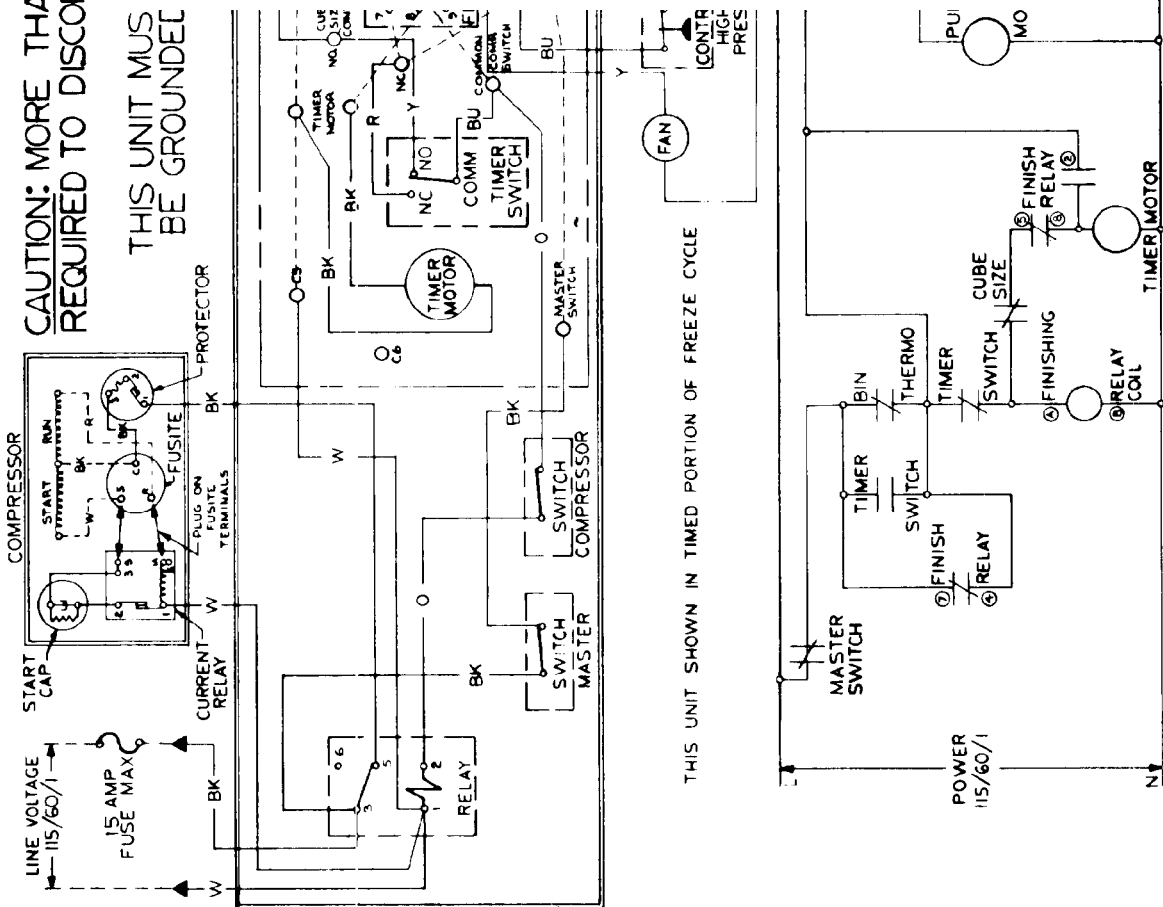

THIS UNIT SHOWN IN TIMED PORTION OF FREEZE CYCLE

NOTE: This Wiring Diagram for use with Model AC-20 Automatic Cubers with Serial Numbers prior to S/N 406754-09R.

Figure 7-1. Wiring Diagram AC-20A - Air-Cooled.

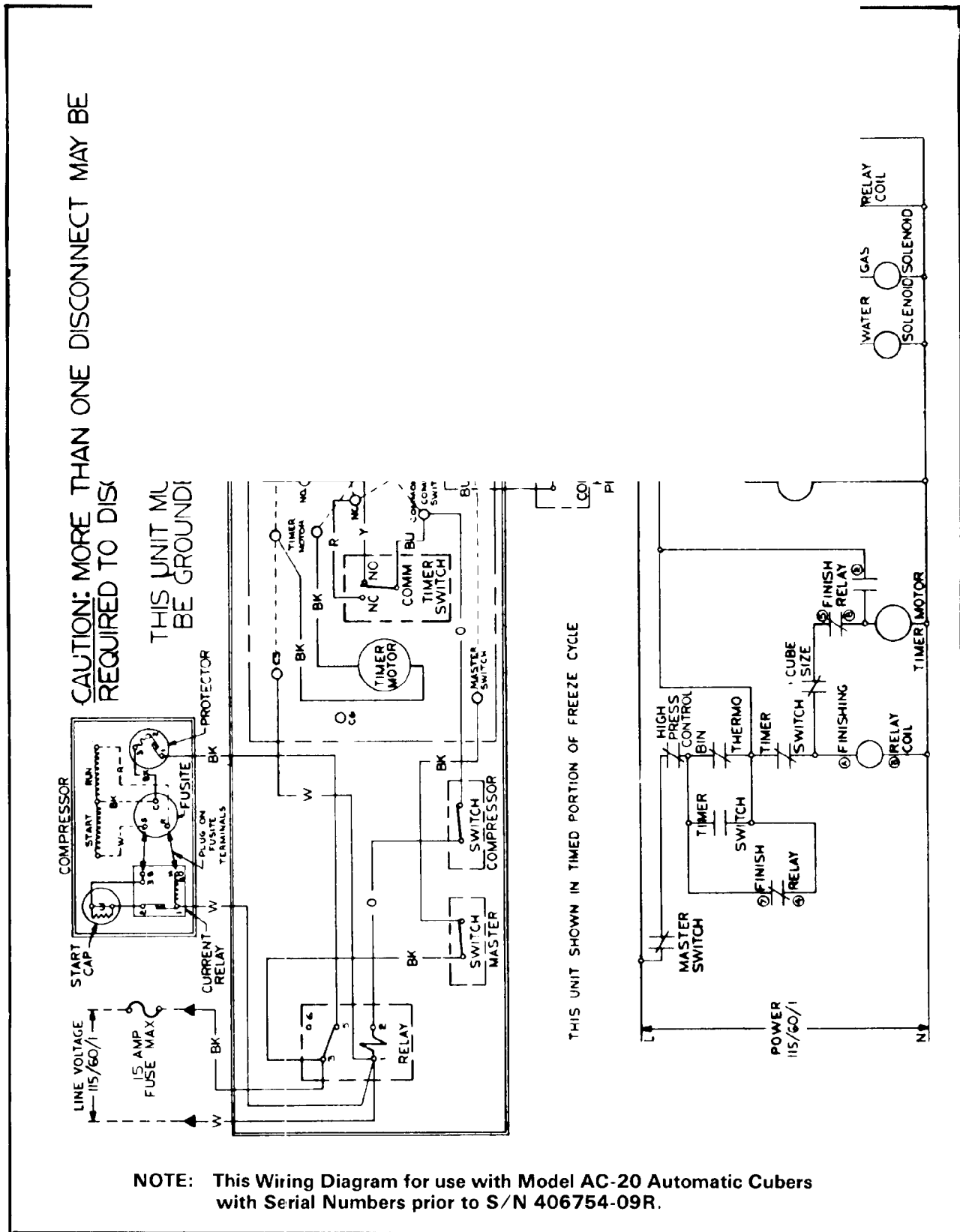
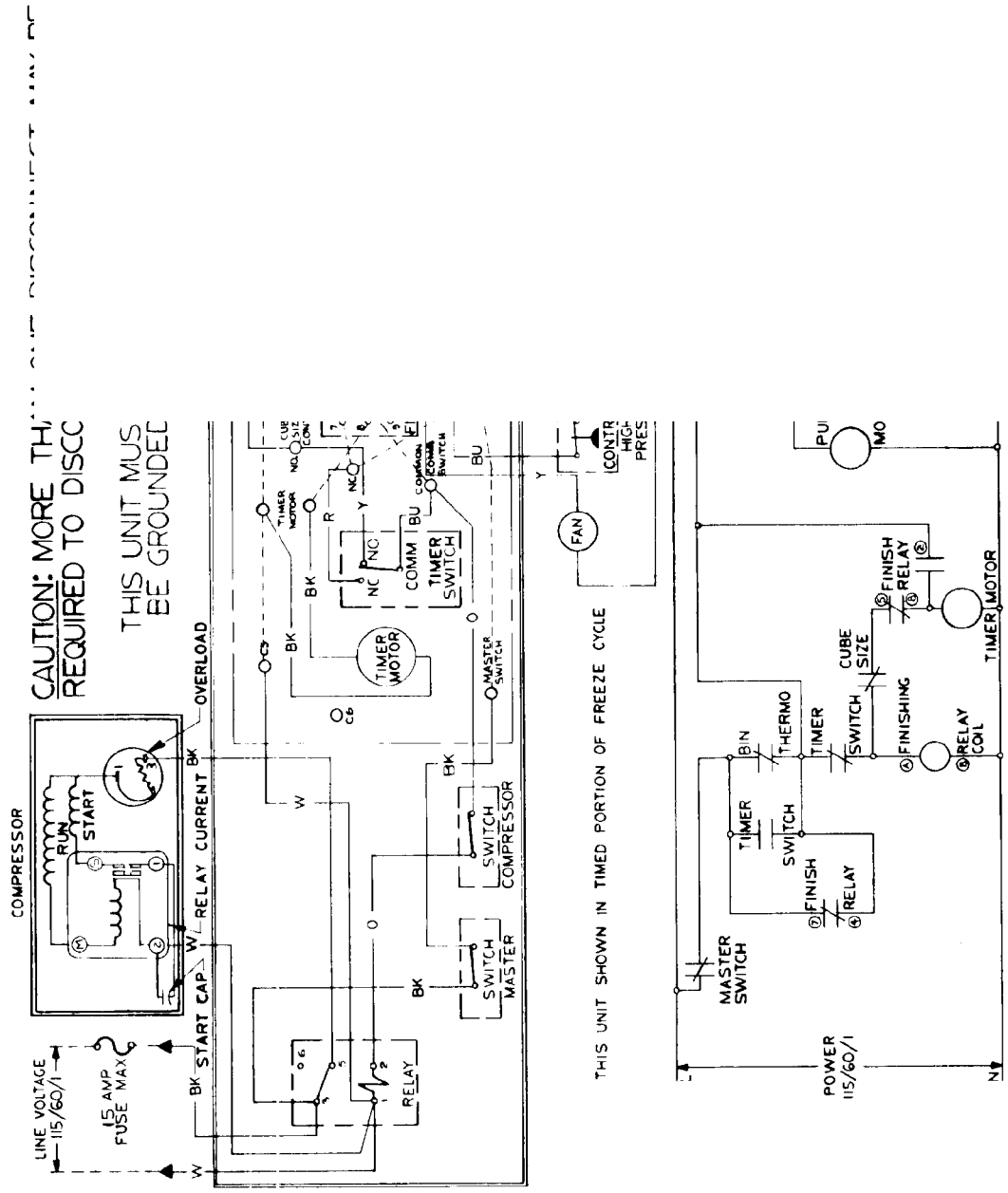

Figure 7-2. Wiring Diagram AC-20A - Water-Cooled.



NOTE: This Wiring Diagram for use with Model AC-20 Automatic Cubers with Serial Numbers 406754-09R and up.

Figure 7-3. Wiring Diagram AC-20B - Air-Cooled.

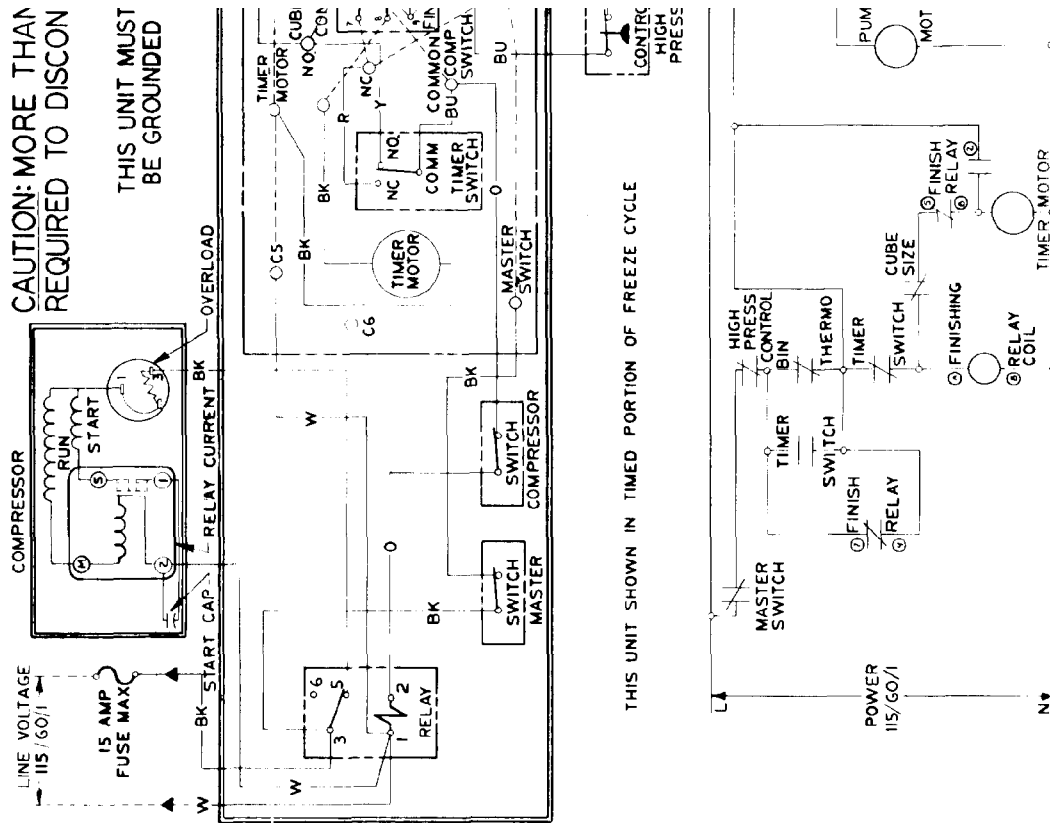

Figure 7-4. Wiring Diagram AC-20B - Water-Cooled.