

AC25 PARTS ILLUSTRATIONS AND PARTS LISTS

THIS SECTION CONTAINS THE PARTS ILLUSTRATIONS AND PARTS LISTS FOR THE AC25.

A NO NUMBER DESIGNATION, WHEN USED IN THE NUMBER COLUMN, INDICATES THE UNIT IS NOT AVAILABLE FROM SCOTSMAN AS AN ASSEMBLY. THIS DESIGNATION IS USED ONLY FOR CLARITY OF DIVISION IN MAKING THE LIST.

WHEN ORDERING PARTS OF ASSEMBLIES, TO AVOID COSTLY DELAYS AND ERRORS IN SHIPMENT, GIVE THE PART NUMBER, THE COMPLETE DESCRIPTION SHOWN IN THE LIST AND THE QUANTITY OF EACH PART OR ASSEMBLY REQUIRED.

TABLE OF CONTENTS

MAJOR ASSEMBLIES	PAGES 2-3
PANEL PARTS	PAGE 4
COMPRESSOR.....	PAGE 5
FREEZING CHAMBER.....	PAGE 6
CONTROL BOX.....	PAGE 7
WIRING DIAGRAM	
AIR COOLED.....	PAGES 8-9
WATER COOLED.....	PAGES 10-11

AC 25 PARTS ILLUSTRATION AND PARTS LIST

MAJOR ASSEMBLIES

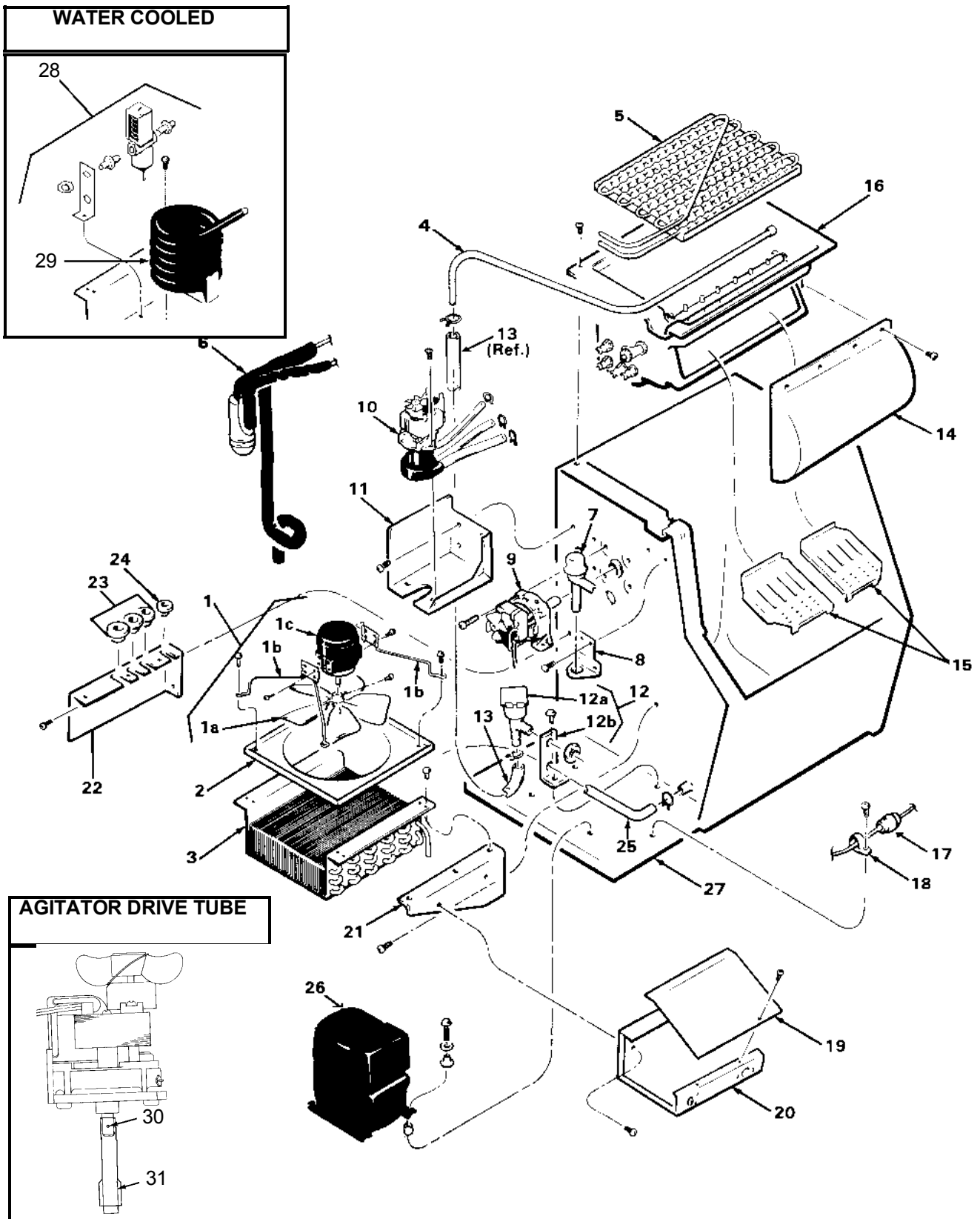

AC25 PARTS LIST

MAJOR ASSEMBLIES

ITEM NUMBER	PART NUMBER	DESCRIPTION	ITEM NUMBER	PART NUMBER	DESCRIPTION
1	No Number	Fan Motor Assembly	18	A09386-000	Drier Brace
1a	18-3715-01	Fan Blade		03-1404-09	Mounting Screw
1b	02-2378-01	Motor Bracket	19	A26955-001	Control Box Cover
1c	12-2050-01	Fan Motor	20	No Number	Control Box Complete
	03-1404-09	Mounting Screw		03-1404-09	Mounting Screw,cov. to Box
2	A26949-001	Fan Shroud	21	no number	Front Mounting Brakcet
3	18-3716-01	Air Cooled Condenser	22	no number	Back Mounting Bracket
	03-0571-00	Shroud To Condenser Screw		03-1405-03	Mounting Screw
4	A26994-001	Defrost Tube	23	12-1213-10	Snap Bushing,(11/16")
5	A27052-020	Evaporator, Medium Cubes	24	12-1213-06	Snap Bushing, (1/2)
	A26946-020	Evaporator, Small Cubes	25	05-0501-01	Preformed Drain Hose
6	A28797-020	Heat Exchanger		02-1338-00	Hose Clamp For The Above
7	12-2008-01	Hot Gas Valve Coil	26	18-4500-01	Compressor
	12-2007-01	Hot Gas Valve Body		18-2200-27	Mounting Sleeve
8	A26956-001	Bracket		18-2200-28	Grommet
	03-1404-09	Mounting Screw		03-1407-07	Washer
	03-1403-14	Mounting Screw		03-1405-20	Mounting Bolt
9	A27735-001	Agitator Motor	27	A26948-002	Bin/ Base Assembly, S/S
	12-0675-25	Fan Blade		A26948-003	Bin / Base Assembly Painted
	03-1403-22	Motor Mounting Screw	28	No Number	Water Regulator Assembly
10	A28961-001	Water Pump		03-0571-00	Bracket Mounting Screw
	03-0571-00	Mounting Screw		A25805-001	Mounting Bracket
	A27068-001	Preformed Tube		11-0198-02	Water Regulating Valve
	13-0674-07	Tygon Tube (6-3/4")	29	18-3707-01	Water Cooled Condenser
	02-1358-01	1 Inch Hose Clamp	30	03-0774-08	Spring Pin
	02-1530-01	15/16" Hose Clamp	31	A27752-001	Drive Tube
11	A26918-001	Pump Bracket			
	03-1404-09	Mounting Screw			
12	No Number	Water Inlet Assembly			
	03-0571-00	Mounting Screw			
12a	12-1900-10	Inlet Water Valve			
	A25969-001	Water Inlet Fitting			
12b	A25805-001	Mounting Bracket			
	03-1394-01	Pal Nut			
13	13-0674-04	Tygon Tube, (34") Order By The Foot			
	03-0535-01	Hose Clamp			
14	02-2353-01	Cube Deflector			
	03-1404-12	Mounting Screw			
15	A27064-001	Cube Chute, Left-med. Cube			
	A27060-001	Cube Chute, Right-med.Cube			
	A26916-001	Cube Chute, Left-small Cube			
	A26923-001	Cube Chute, Right-sm. Cube			
16	02-2331-01	Water Reservoir Only			
	03-1404-12	Mounting Screw			
17	02-3319-01	Drier			

AC25 PARTS ILLUSTRATION AND PARTS LIST

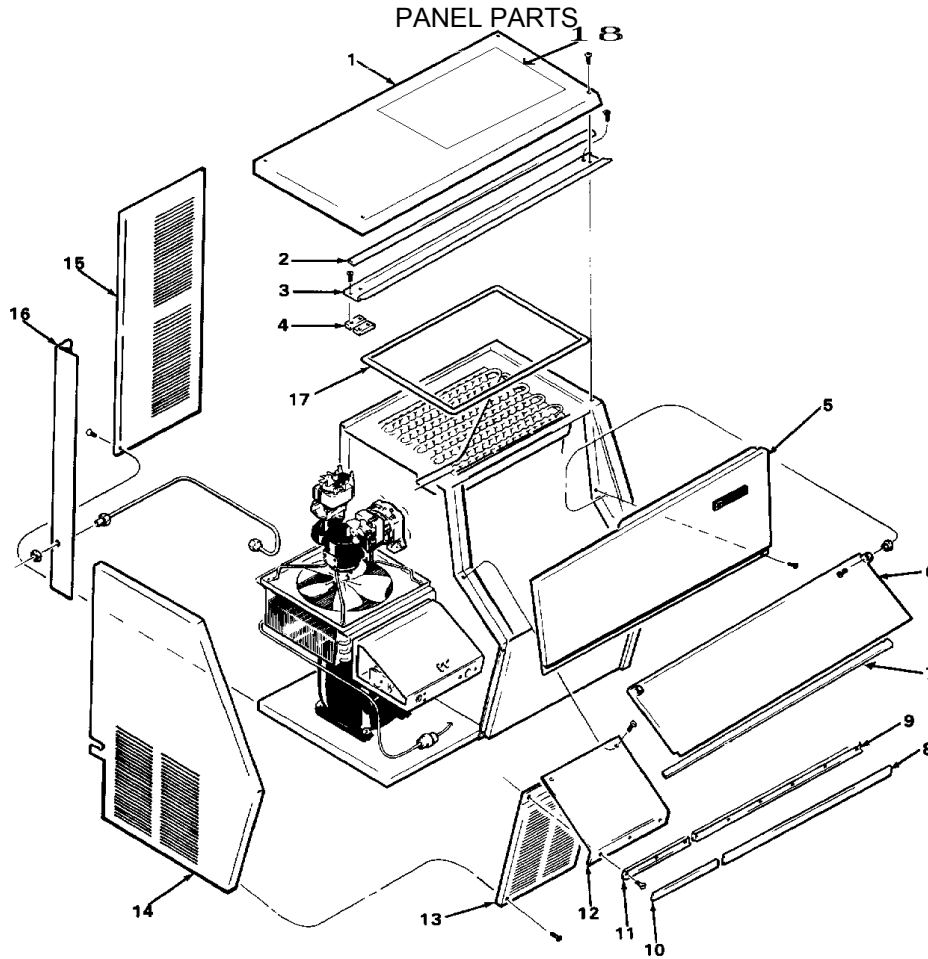

ITEM NUMBER	PAF NUMBER	DESCRIPTION	NUMBER	NUMBER	DESCRIPTION	
1	A26931-005	Top Panel, sandalwood	10	15-0618-01	Moulding Cover 11.75	
	A26931-015	Top panel, gray	11	15-0616-01	Left Track Section	
	A26931-004	Top Panel, Stainless		03-1404-04	Mounting Screw	
	03-1419-09	Mounting Screw	12	A26921-005	Baffle, sandalwood	
2	13-0595-00	Gasket (34") Order per foot		A26921-015	Baffle, gray	
	3	A28213-001	Top Brace		A26921-004	Baffle, S. S.
		no number	Spacer		03-1419-10	Mounting Screw
	4	03-1404-12	Mounting Screw	13	A26928-005	Lower L. Fr. Pnl. sandalwood
03-1404-10		Mounting Screw	A26928-015		Lower L. F. panel, gray	
5		obsolete	Upper Front Pnl. sandalwood		A26928-004	Lower L. Fr. Pnl. S. S.
		obsolete	Upper front panel, gray		03-1419-09	Mounting Screw
6	A26935-003	Upper Front Pnl. S.s.	14	A27520-004	Left Side Panel, sandalwood	
	03-1404-10	Mounting Screw		A27520-015	Left side panel, gray	
	7	02-2332-34		Door, only gray is available	A27520-002	Left Side Panel, S.s.
		02-2380-01		Hinge Bushing	03-1404-10	Mounting Screw s.s.
8	03-1405-07	Hinge Screw	15	A26945-001	Rear Panel	
	13-0595-00	Gasket (33") Order per foot		03-1404-09	Mounting Screw	
9	15-0619-01	Moulding Cover 22.44"		16	A27066-003	Left Rear corner, sandalwood
	15-0617-01	Track Section 21"			A27066-015	Left rear corner, gray
10	03-1404-07	Mounting Screw	A27066-002		Left Rear Corner, S.s.	
			17		13-0595-00	Gasket, (67") Order per foot
11			18	A26917-001	Plastic Liner, Top Panel	

AC25 PARTS ILLUSTRATION AND PARTS LIST

COMPRESSOR

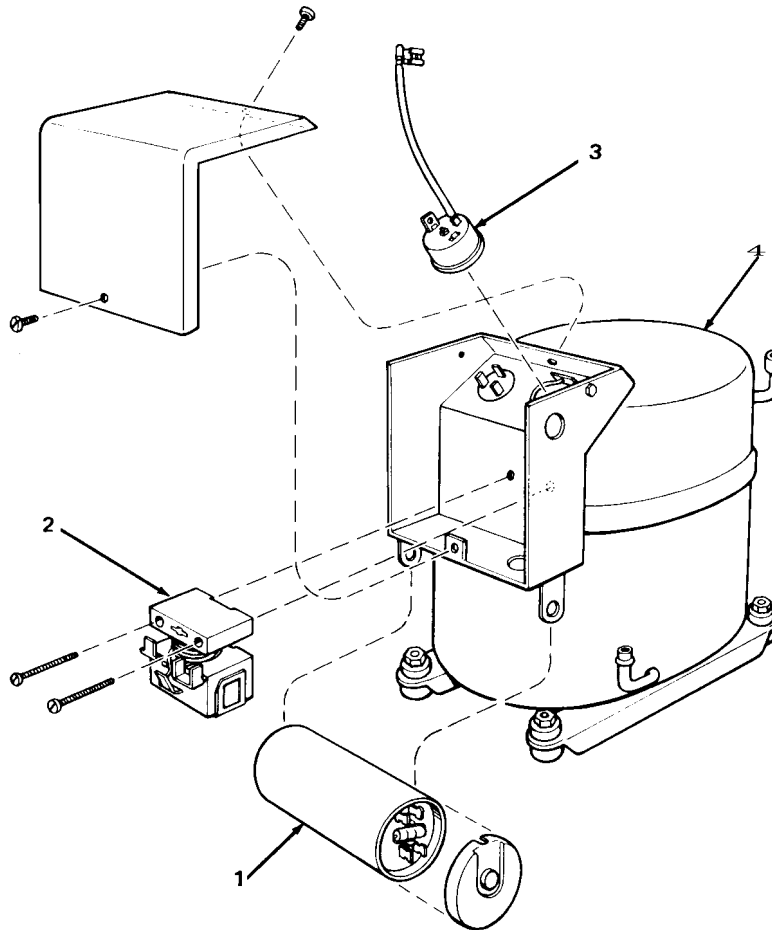

ITEM NUMBER	PART NUMBER	DESCRIPTION
1	18-1901-33	START CAPACITOR WITH CAP
2	18-2200-26	RELAY
3	18-2200-25	OVERLOAD
4	18-4500-01	COMPRESSOR INCLUDES ITEMS 1,2,AND 3.

AC25 PARTS ILLUSTRATION AND PARTS LIST

FREEZING CHAMBER

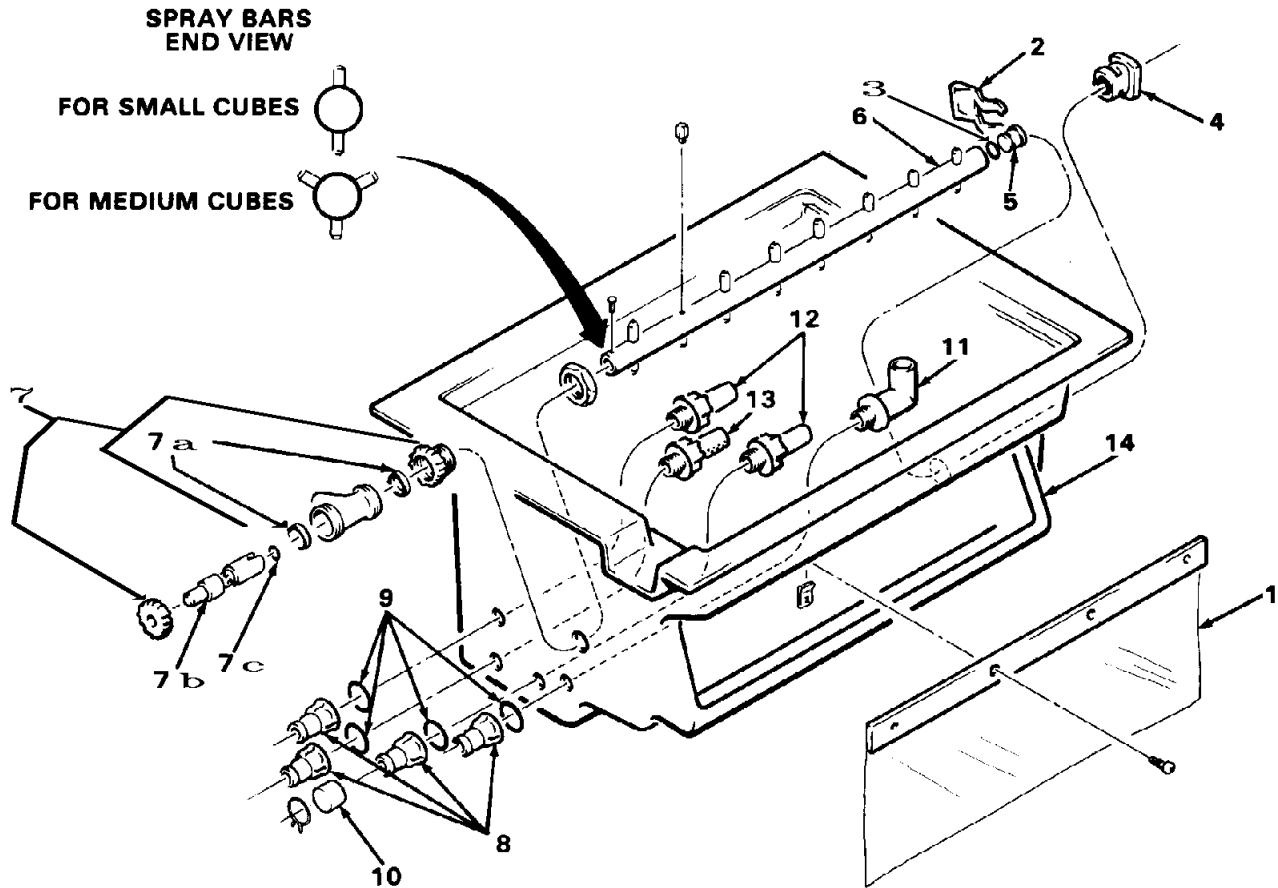

ITEM NUMBER	PART NUMBER	DESCRIPTION	ITEM NUMBER	PART NUMBER	DESCRIPTION
1	02-2327-01	Curtain	7b	02-2427-01	Drive Journal
	03-1403-10	Mounting Screw	7c	13-0617-30	O-ring
	03-1422-04	Speed Nut	8	02-2606-01	Female Tube
2	A26901-001	Retaining Clip	9	13-0617-02	O-ring
3	13-0617-42	O-ring	10	13-0796-01	Rubber Cap
4	02-2419-01	Spray Bar End		02-1530-01	Hose Clamp
5	02-2420-01	Spray Bar Plug	11	02-2125-01	Stand Pipe
6	A27756-001	Spray Bar, small Cube	12	02-2080-01	Male Tube
	A27755-001	Spray Bar, Med. Cube	13	02-2082-01	Pump Pick Up Tube
	02-1803-01	Jet, med. Cube (24) small Cube (2)	14	02-2331-01	Freezing Chamber
	02-2663-01	Jet, Small Cube (22)			
7	02-2418-01	Drive Housing, Includes 7a, but not 7b or 7c			
7a	13--0819-01	U-cup Seal++			

AC25 PARTS ILLUSTRATION AND PARTS LIST

CONTROL BOX

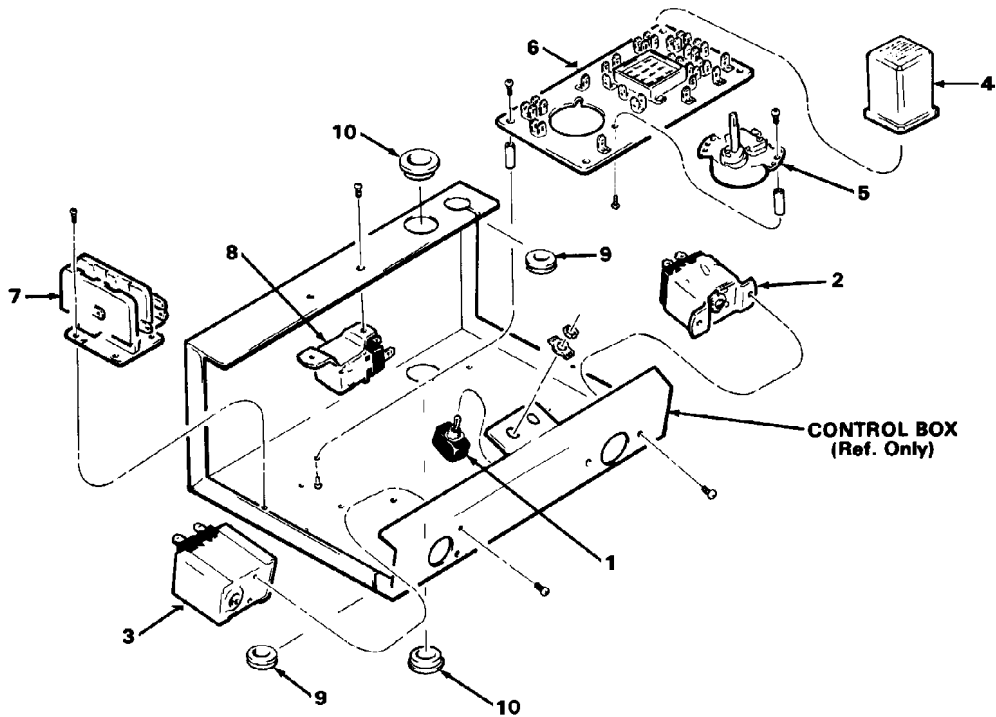

ITEM NUMBER	PART NUMBER	DESCRIPTION	ITEM NUMBER	PART NUMBER	DESCRIPTION
1	12-0426-01	Toggle Switch	6	12-1912-01	P.C. Board
2	11-0345-23	Cube Size Control		02-2242-02	Stand Off (5/8")
	03-1403-14	Mounting Screw		03-1403-02	Mounting Screw
3	11-0389-22	Fan Control, Air Cooled Models	7	12-2469-03	Contactor
	11-0388-21	High Pressure Control. Water Cooled	8	11-0353-23	Bin Thermostat
	03-1403-02	Mounting Screw	9	13-0115-00	Grommet
4	12-1879-02	Relay	10	12-1213-10	Bushing
5	12-1980-01	Timer With Switch			
	02-2242-01	Stand Off (7/8")			
	03-1403-02	Mounting Screw			

AC25 COMPONENT LAY OUT DIAGRAM

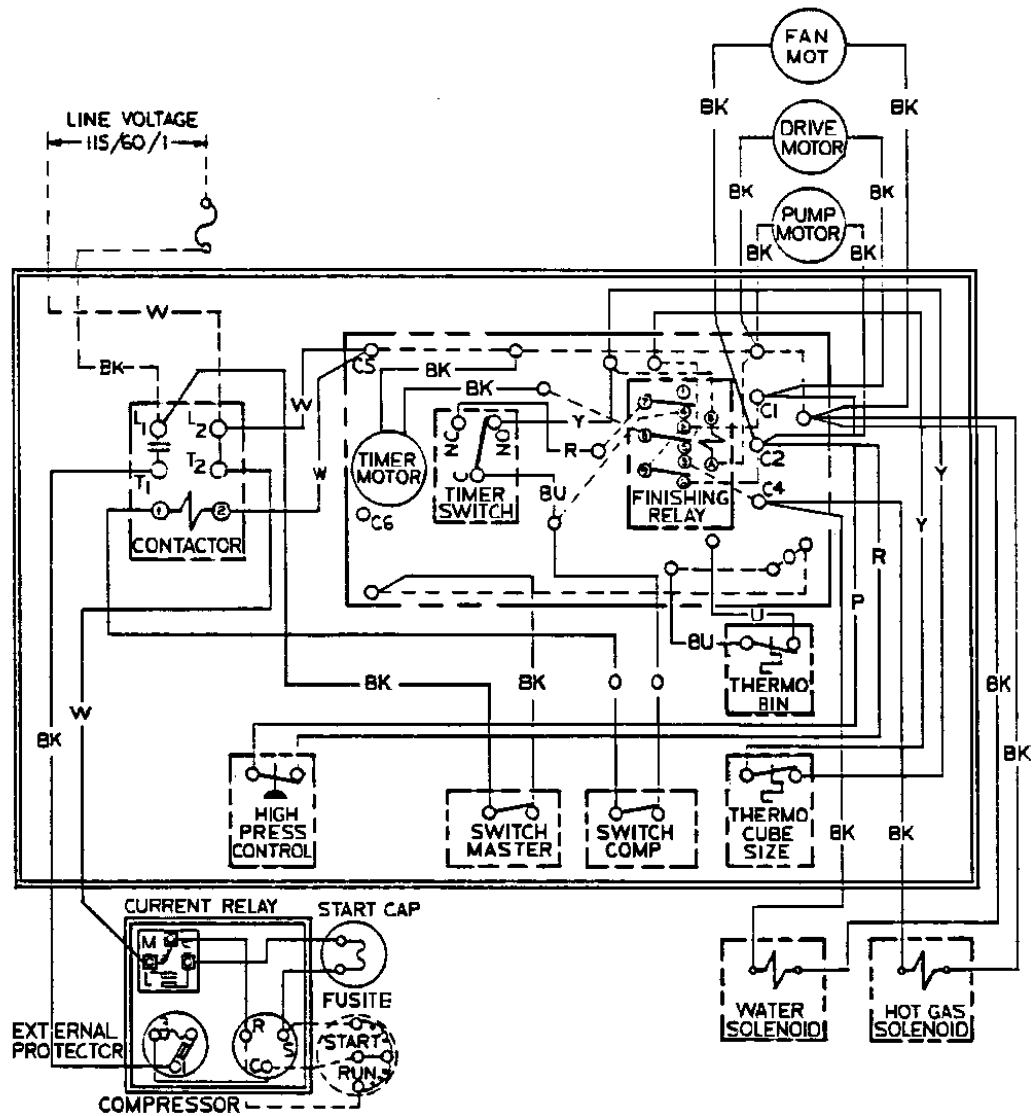

THIS UNIT MUST BE GROUNDED

AC25 AIR COOLED, 115V/60/1

AC25 SCHEMATIC DIAGRAM

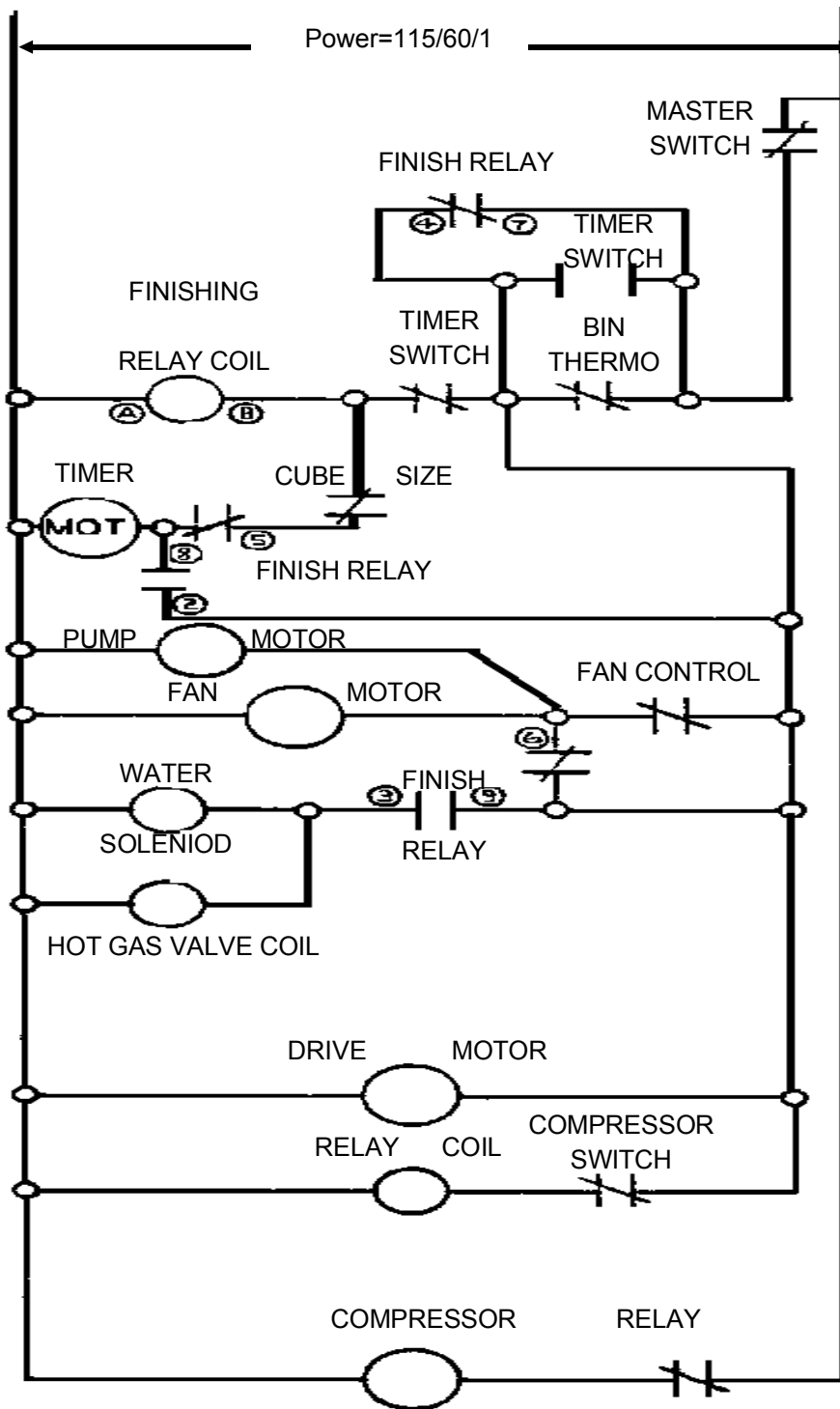

AC25 AIR COOLED, 115V/60/1

AC25 COMPONENT LAY OUT DIAGRAM

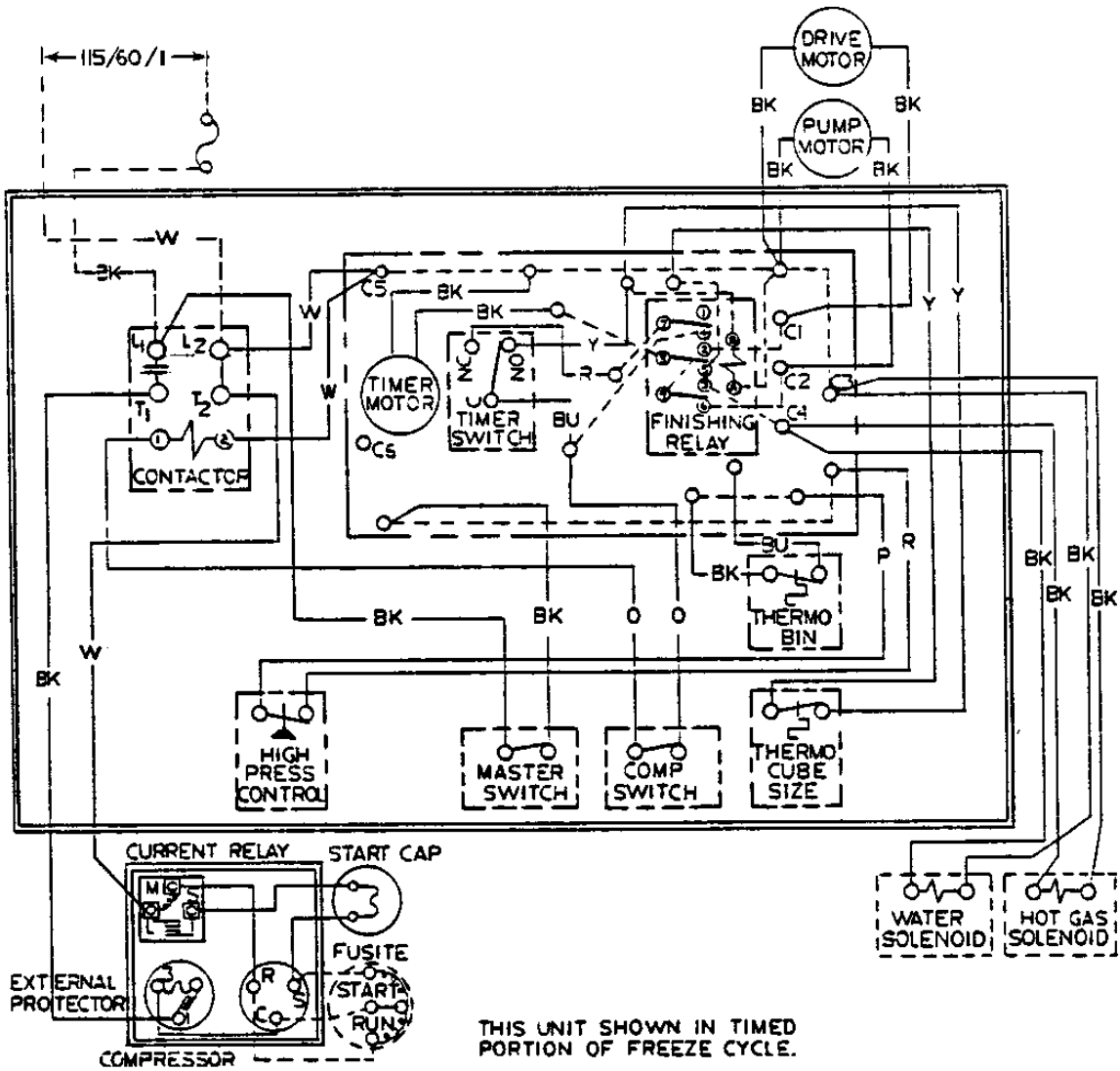

AC25 WATER COOLED, 115V/60/1

AC25 SCHEMATIC DIAGRAM

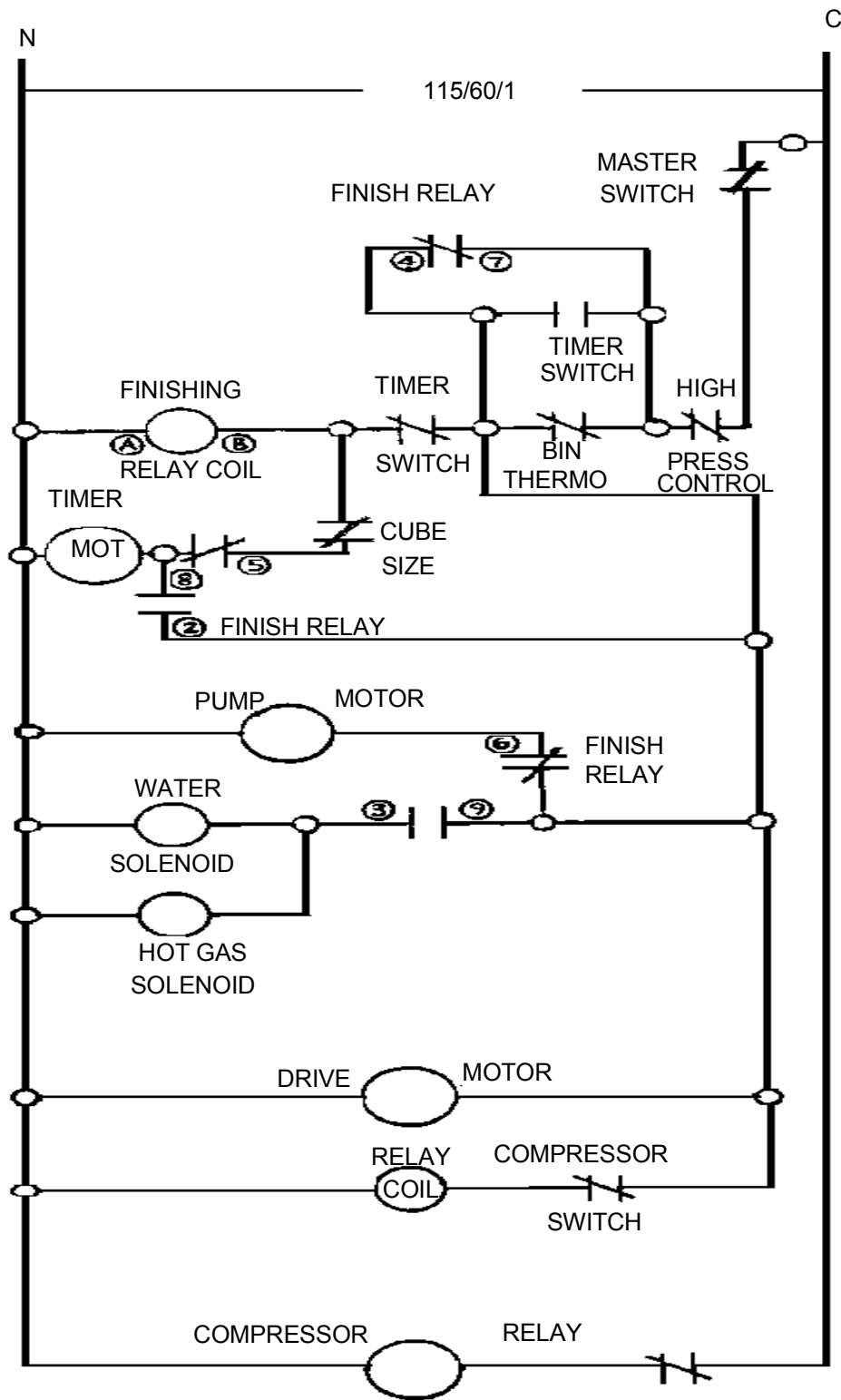

AC25 WATER COOLED, 115V/60/1