

AFE400 SERVICE PARTS

This is the parts list for the AFE400. When looking up part numbers, always check the complete model and serial numbers to be certain of ordering the correct parts.

The Air Cooled model has also been manufactured in 50 Hz.

The water cooled A and B series models have different water cooled condensers. Be sure to check the complete model number.

The C series has a different compressor. Be sure to check the complete model number.

The gear reducer changed design in February 2007. Confirm the part number from the tag on the gear reducer to supply the correct part.

Plastic tubing is sold by the foot, order 1 unit, and 1 foot will be shipped. Order enough to cover the length required. Lengths of tubing are listed under the description column.

Table of Contents

CABINET	Page 2
AIR COOLED REFRIGERATION	Page 3
WATER COOLED REFRIGERATION	Page 4
RESERVOIR AND TUBING	Page 5
Evaporator	Page 6
Prior Gear Reducer A31977	Page 7
Gear Reducer 02-4399-21 or 02-4399-24 or 02-4398-21	Page 8
CONTROL BOX	Page 9
SCHEMATIC DIAGRAM	Page 10
WIRING DIAGRAM	Page 11

AFE400 SERVICE PARTS

CABINET

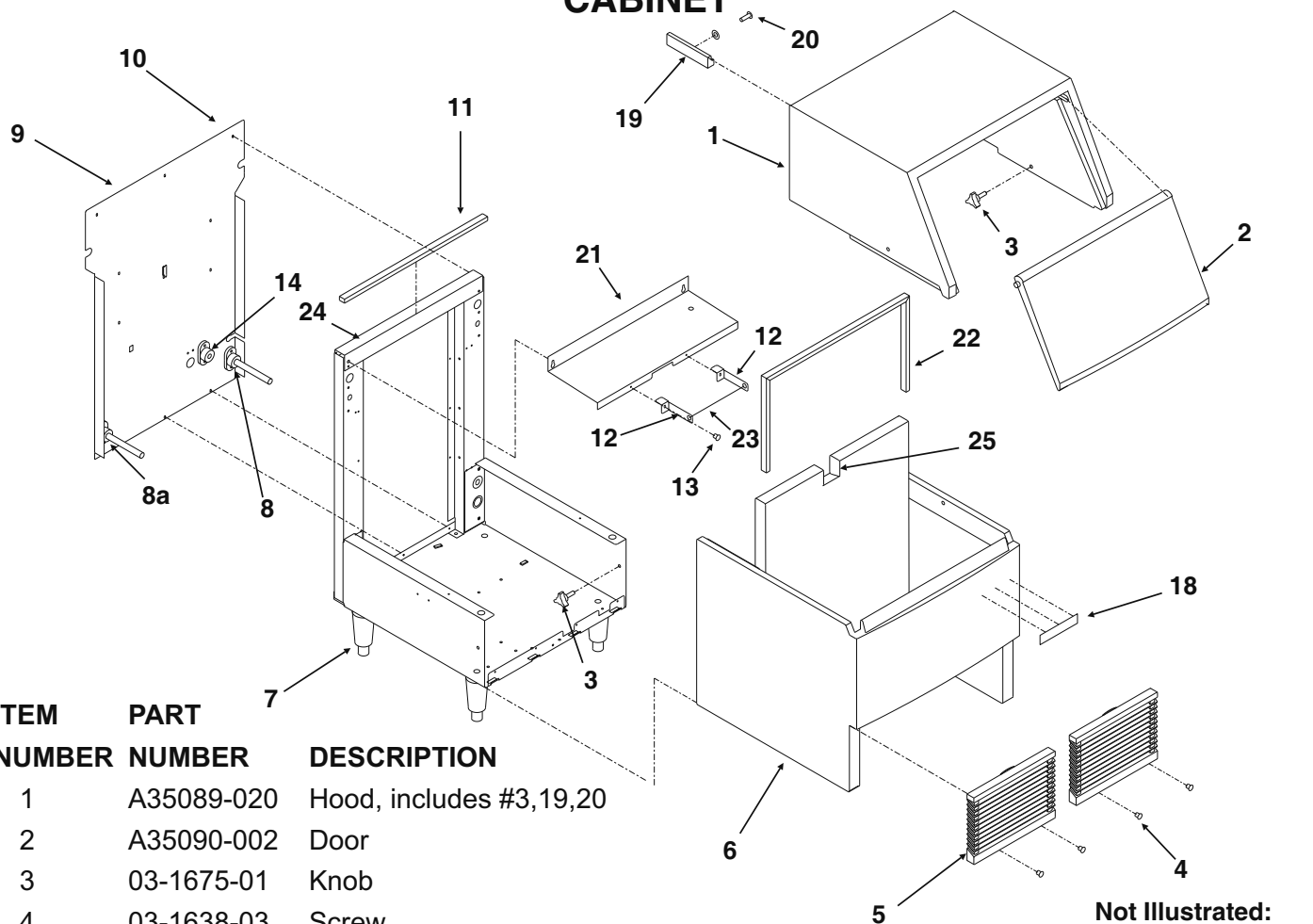

ITEM NUMBER	PART NUMBER	DESCRIPTION
1	A35089-020	Hood, includes #3,19,20
2	A35090-002	Door
3	03-1675-01	Knob
4	03-1638-03	Screw
5	02-3153-01	Grill
6	A35088-020	Bin, includes #15,16,16a, 17
7	KLP2E	Leg kit
8	02-3692-21	Drain casting - bin
8a	02-3692-22	Drain casting - reservoir
9	A35248-001	Back panel
10	03-1404-29	Sheet metal screw
11	13-0609-01	Gasket, 21.75" req.
12	A35394-001	Bin control bracket
	13-0727-00	Grommet
13	03-1638-03	Screw
14	16-1154-22	Water cooled drain fitting
15	02-2809-02	Drain cap
16	02-3108-01	Drain fitting
16a	02-4193-01	Washer - flat
17	16-0822-01	Adaptor
18	15-0808-01	Emblem
19	19-0629-01	Door stop

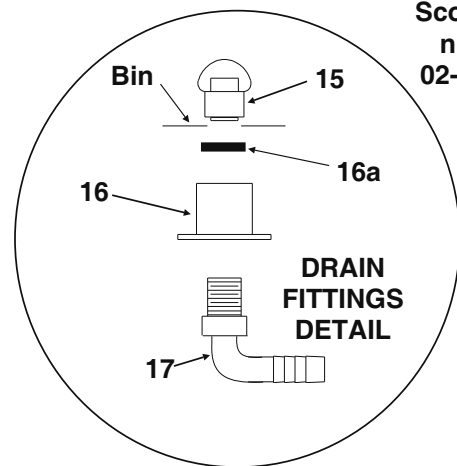

Not Illustrated:
Scoop, part number 02-3253-01

20	03-1419-09	Screw
21	A35199-001	Evaporator bracket
	13-0727-00	Grommet for cap tube
22	13-0909-01	Bin gasket 36" req.
23	A35395-001	SS Bin control tube (prior)
	13-0895-01	Plastic tube - 9" req.
24	A35452-001	Top bracket
25	13-0892-01	Spout grommet

AFE400 SERVICE PARTS

AIR COOLED REFRIGERATION

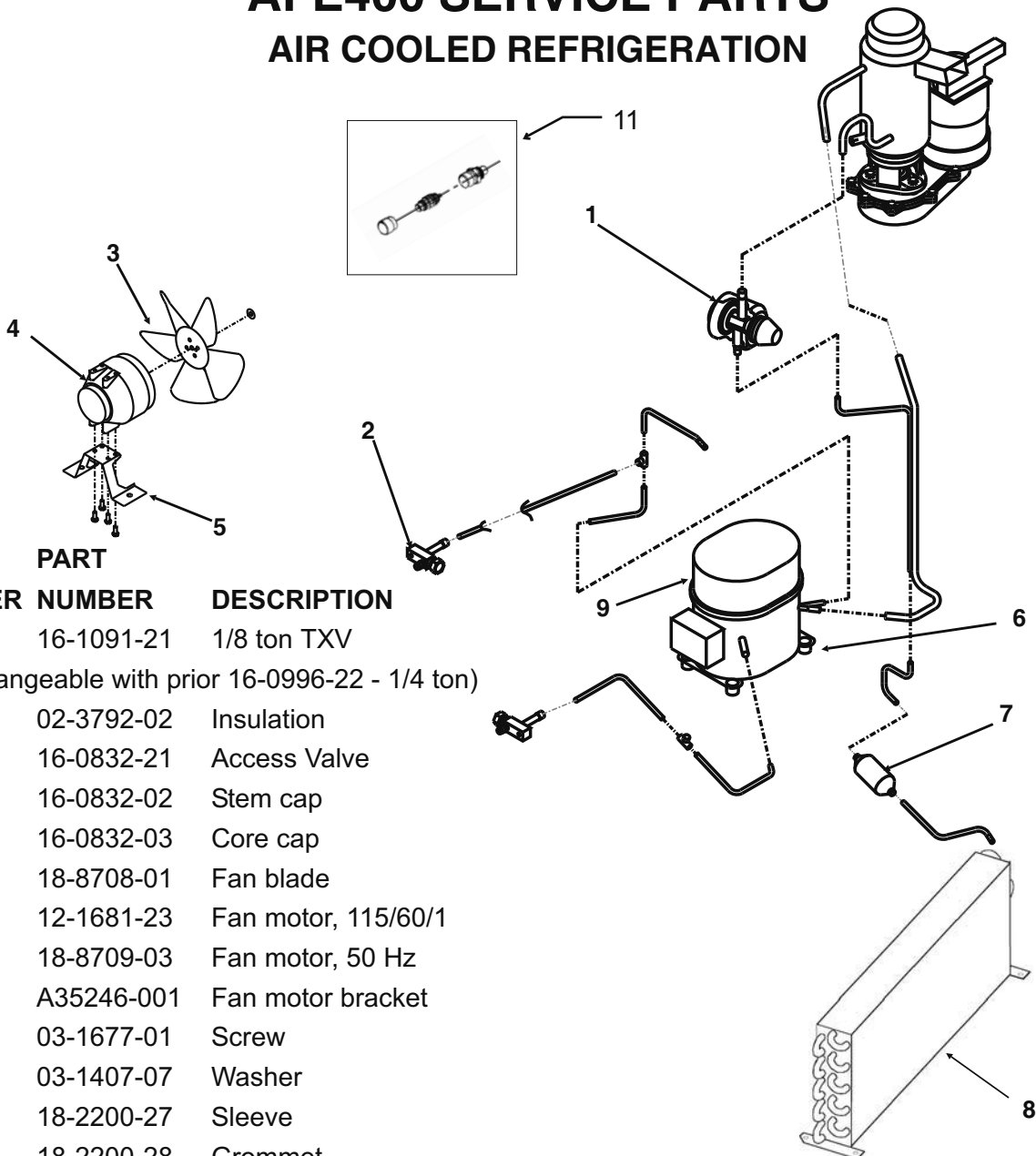

ITEM NUMBER	PART NUMBER	DESCRIPTION
1	16-1091-21	1/8 ton TXV (interchangeable with prior 16-0996-22 - 1/4 ton)
	02-3792-02	Insulation
2	16-0832-21	Access Valve
	16-0832-02	Stem cap
	16-0832-03	Core cap
3	18-8708-01	Fan blade
4	12-1681-23	Fan motor, 115/60/1
	18-8709-03	Fan motor, 50 Hz
5	A35246-001	Fan motor bracket
6	03-1677-01	Screw
	03-1407-07	Washer
	18-2200-27	Sleeve
	18-2200-28	Grommet
7	02-3319-01	Dryer
8	18-8844-01	Air cooled condenser
	02-3193-01	Air filter (not shown)
9	18-8918-21	60 Hz Compressor*
	18-8746-26	50 Hz Compressor*

A or B and 50 Hz C series (Tecumseh compressor) parts:

18-8746-29	Start capacitor
18-8746-28	Relay
18-8746-27	Overload
18-8746-25	50 Hz Start capacitor
18-8746-24	50 Hz Relay
18-8746-23	50 Hz Overload

10 11-0501-24 Hi pressure cut out
(for those units mfg. with one, use began 12/05)

60 Hz C series (Danfoss compressor) parts:

18-1903-60	60 Hz relay w/overload
18-1901-60	60 Hz start capacitor

* Includes relay, overload, start capacitor, and drier

Alternate Access Valve, use began 2009

11	16-1138-01	Access valve seat
	16-1139-01	Core
	16-1140-01	Cap

AFE400 SERVICE PARTS

WATER COOLED REFRIGERATION

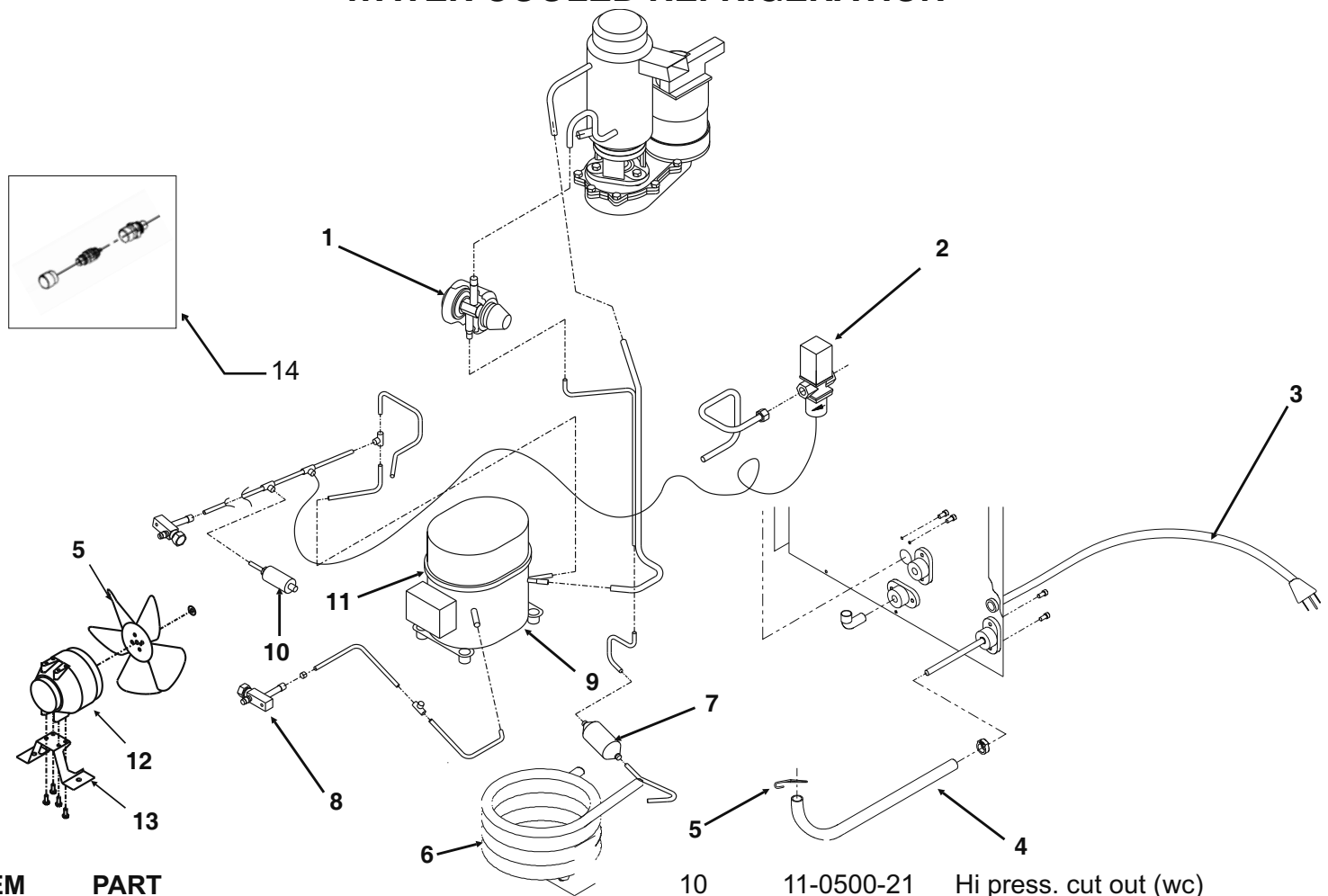

ITEM NUMBER	PART NUMBER	DESCRIPTION
1	16-1091-21	TXV
	02-3792-02	Insulation
2	11-0198-02	Water reg. valve
3	12-1638-15	Power cord 60 Hz (AC also)
	12-1638-16	Power cord for 50 Hz.
4	13-0079-03	Tubing (21" req.)
5	18-8708-01	Fan blade
6	18-3707-25	A series w c condenser
	18-8869-21	B & C series w c condenser
7	02-3319-01	Dryer
8	16-0832-21	Access valve
	16-0832-02	Stem cap
	16-0832-03	Core cap
9	03-1677-01	Screw
	03-1407-07	Washer
	18-2200-27	Sleeve
	18-2200-28	Grommet
10	11-0500-21	Hi press. cut out (wc)
11	18-8918-21	60 Hz Compressor*
	18-8746-26	50 Hz Compressor.*
A or B and 50 Hz C series (Tecumseh comp) parts:		
	18-8746-29	Start capacitor
	18-8746-28	Relay
	18-8746-27	Overload
	18-8746-25	50 Hz Start capacitor
	18-8746-24	50 Hz Relay
	18-8746-23	50 Hz Overload
60 Hz C series (Danfoss compressor) parts:		
	18-1903-60	60 Hz relay w/overload
	18-1901-60	60 Hz start capacitor
12	18-8752-21	Fan motor (water cooled)
13	A35246-001	Fan motor bracket
* Includes relay, tubing, start capacitor, and drier		
Alternate Access Valve, use began 2009		
14	16-1138-01	Access valve seat
	16-1139-01	Core
	16-1140-01	Cap

AFE400 SERVICE PARTS

RESERVOIR AND TUBING

ITEM NUMBER	PART NUMBER	DESCRIPTION
1	13-0895-01	Poly Tubing
2	obsolete	Compr. sleeve
3	16-0871-01	Brass insert
4	16-0162-00	Strainer - not used after 10/97
5	02-3268-01	Clip
6	11-0296-00	Water pressure sw.
6a	16-1046-01	Plastic tube connector to switch
7	13-0859-01	Rubber plug
8	13-0674-04	Drain tube, 12" req.
9	02-2814-07	Hose clamp
10	13-0674-04	Outlet tube, 4" req.
11	16-0670-02	Tee
12	13-0674-04	Evap. inlet tube, 6" req.
13	13-0079-03	Overflow tube, 32" req.
14	02-2217-01	Reservoir & valve
15	02-2217-02	Float valve
16	16-0835-01	Male flare connector, used with item 17
17	16-1081-01	Inlet elbow, used with male connector and plastic tubing
18	16-1040-01	Inlet T

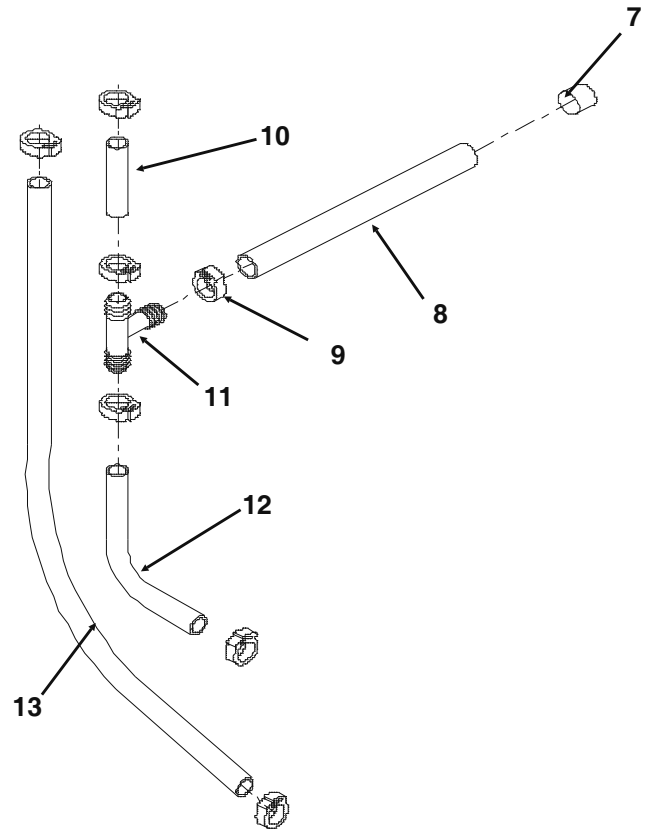
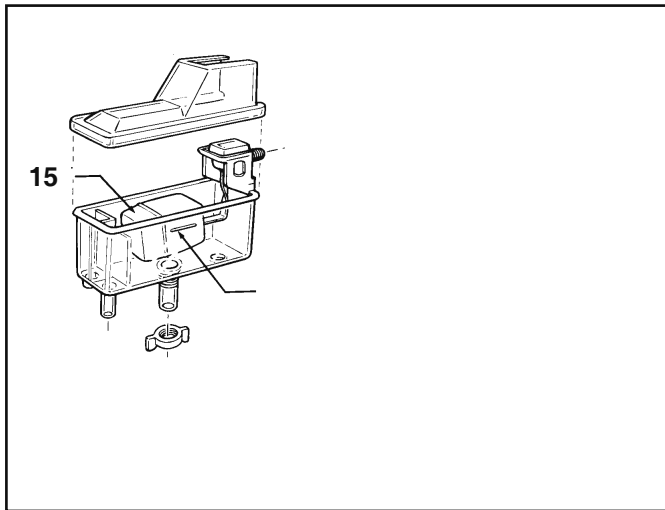
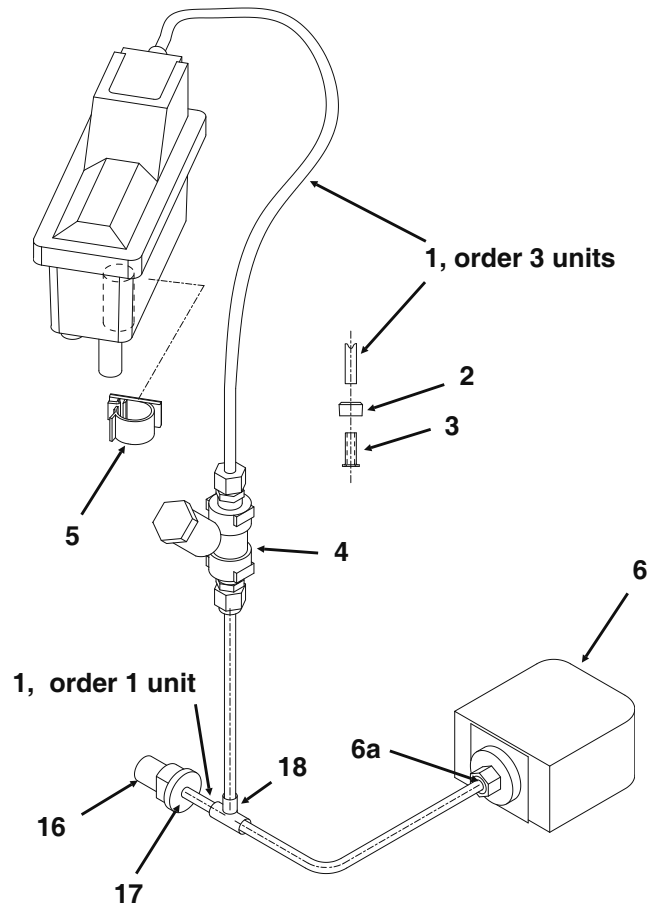

AFE400 SERVICE PARTS

Evaporator

ITEM NUMBER	PART NUMBER	DESCRIPTION
1	02-4404-02	Threaded cap - grey
2	03-0758-00	Screw
3	02-4535-01	Top bearing, w/thrust washer - for updated units*
4	02-4575-21	Breaker kit, includes items 1, 3, 4a, 4b, 7 & 7a*
4a	13-0617-16	O-Ring (inside)
4b	13-0617-37	O-Ring, outside of breaker
5	02-4574-01	Auger - for updated units*
6	02-3449-20	Evaporator
7	03-1417-07	Washer
7a	03-1403-46	Screw
8	02-4599-21	Water Seal
9	02-0417-21	Lower Bearing
10	03-1505-00	Gasket
11	08-0595-01	Adapter
12	03-1405-38	Cap Screw (3)
13	03-1420-01	Cap screw
14	03-1410-04	Washer (3)
15	A29915-002	Spline Coupling
16	02-4578-01	Auger and bearing kit

Includes items 1, 2, 4, 4a, 4b, 5, 7, 7a, 8, and 9

17 19-0662-02 Top bearing grease, 13 oz tube

Note: Use about 1 oz per bearing. Lightly coat bearing surfaces, thoroughly grease thrust portion of bearing (horizontal needles).

* Updated units have new auger and top breaker and bearing.

Update available beginning Feb. 2010. Updated units have grey cap. Non-updated units require auger kit item 16 when replacing top bearing or auger.

Note: Original AFE400 had o-ring

13-0617-45 to hold foam cap halves 13-0886-01.

Also had rubber cap 13-0887-01. Not used after 2007.

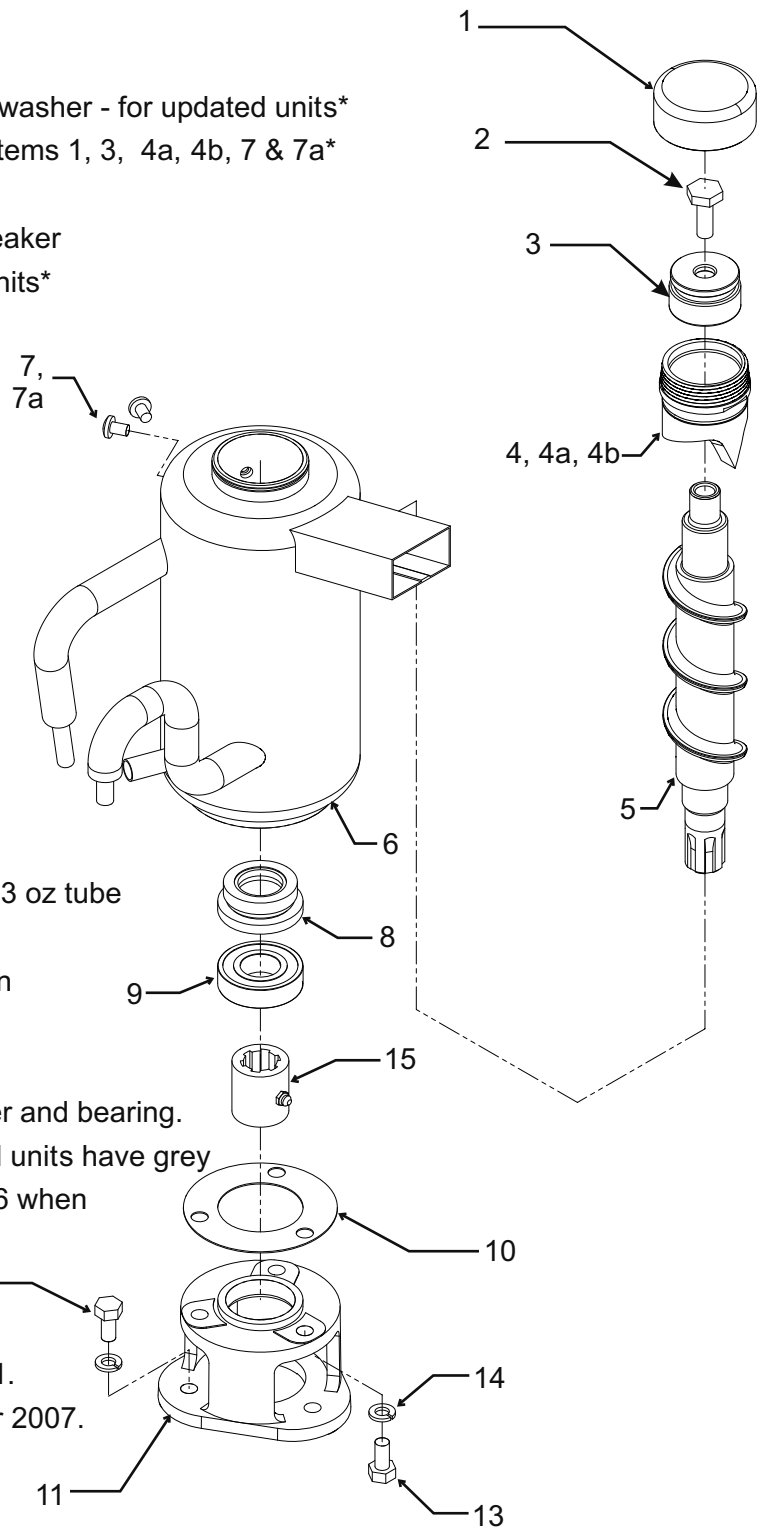

AFE400 SERVICE PARTS

Prior Gear Reducer A31977

ITEM NUMBER	PART NUMBER	DESCRIPTION
-------------	-------------	-------------

- | | | |
|-----|----------------------|------------------------------------|
| 1. | 12-2059-01 | Switch |
| 2. | none, part of item 3 | |
| 3. | A27494-001 | Centrifugal Sw. Kit |
| 4. | 03-1403-77 | Screw |
| 5. | A30579-001 | Shaft and Actuator |
| 6. | 03-1408-36 | Washer |
| 7. | 02-1503-00 | Grease seal |
| 8. | 03-1408-21 | Washer |
| 9. | 03-1408-04 | Washer |
| 10. | 02-2445-01 | Output shaft |
| 11. | 03-1515-03 | Retaining ring |
| 12. | 03-1602-01 | Woodruff Key |
| 13. | 02-2444-01 | Output gear |
| 14. | 02-1505-00 | O-ring |
| 15. | 03-0774-11 | Roll pin |
| 16. | A28166-001 | Gear Case |
| 17. | 03-1408-39 | Washer |
| 18. | 03-1408-40 | Washer shim |
| 19. | 02-2439-01 | Second gear and third pinion |
| 20. | 03-1408-41 | Washer |
| 21. | 03-1408-38 | Washer |
| 22. | 02-2438-01 | First gear and second pinion |
| 23. | A28165-021 | Gear box cover |
| 24. | 02-3969-20 | Grease seal |
| 25. | 02-1501-00 | Bearing |
| 26. | 03-1408-08 | Washer |
| 27. | A37707-021 | 60 Hz motor kit* |
| 28. | A38501-001 | 50 Hz motor kit* |
| 29. | A28168-001 | Fan |
| 30. | A38487-001 | Motor Housing with bearing |
| 31. | A32379-027 | Oil |
| 32. | 02-4399-21 | Complete 60 Hz Gear Motor Assembly |
| | 02-4399-24 | Complete 50 Hz Gear Motor Assembly |
| | 02-4398-21 | Gear reducer kit, no motor |
| 33. | A24295-001 | Spacer |
| 34. | 03-1408-02 | Washer |
| 35. | 03-1405-45 | Screw |
| 36. | 13-0639-00 | Grommet |

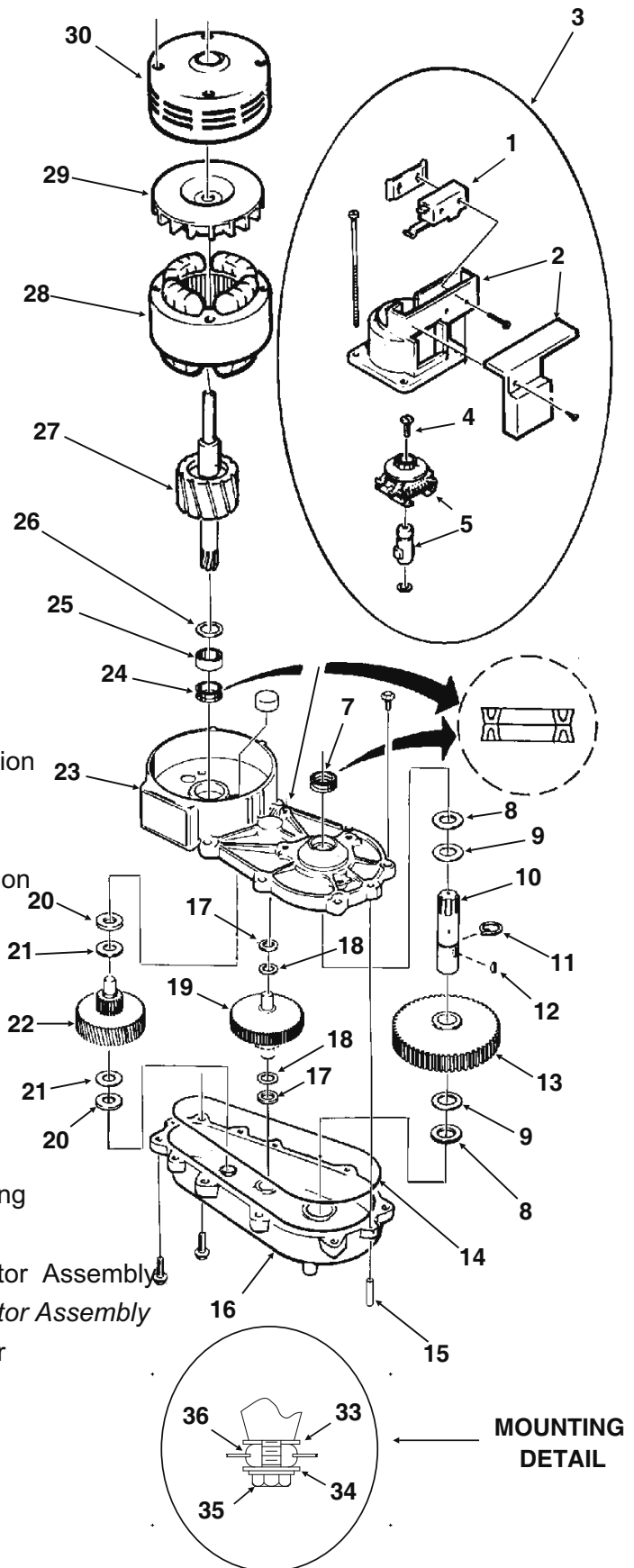

* motor kit includes items 25, 26, 29 and 30.

AFE400 SERVICE PARTS

Gear Reducer 02-4399-21 or 02-4399-24 or 02-4398-21

ITEM NUMBER	PART NUMBER	DESCRIPTION
1.	12-2059-01	Switch
2.	A27494-001	Centrifugal Sw. Kit
3.	03-1403-77	Screw
4.	A30579-001	Shaft and Actuator
5.	part of item 2	
6.	03-1408-36	Washer
7.	02-1503-00	Grease seal
8.	13-0947-01	Gasket
9.	03-1408-39	Washer
10.	03-1408-40	Washer shim
11.	02-2439-01	Second gear and third pinion
12.	03-1408-41	Washer
13.	03-1408-38	Washer
14.	02-2438-01	First gear and second pinion
15.	02-3969-20	Grease seal
16.	02-1501-00	Bearing
17.	03-1408-08	Washer
18.	A37707-021	60 Hz motor kit*
19.	A28168-001	Fan
20.	A38487-001	Motor Housing with bearing
21.	A32379-027	Oil - 16 oz bottle, use 5 oz
22.	02-4399-21	Complete 60 Hz Gear Motor Assembly with motor
	02-4399-24	Complete 50 Hz Gear Motor Assembly with motor
	02-4398-21	Gear reducer kit, no motor
23.	A24295-001	Spacer
24.	03-1408-02	Washer
25.	03-1405-45	Screw
26.	13-0639-00	Grommet
27.	13-0941-01	Water shed

* motor kit includes items 16, 17, 19, 20

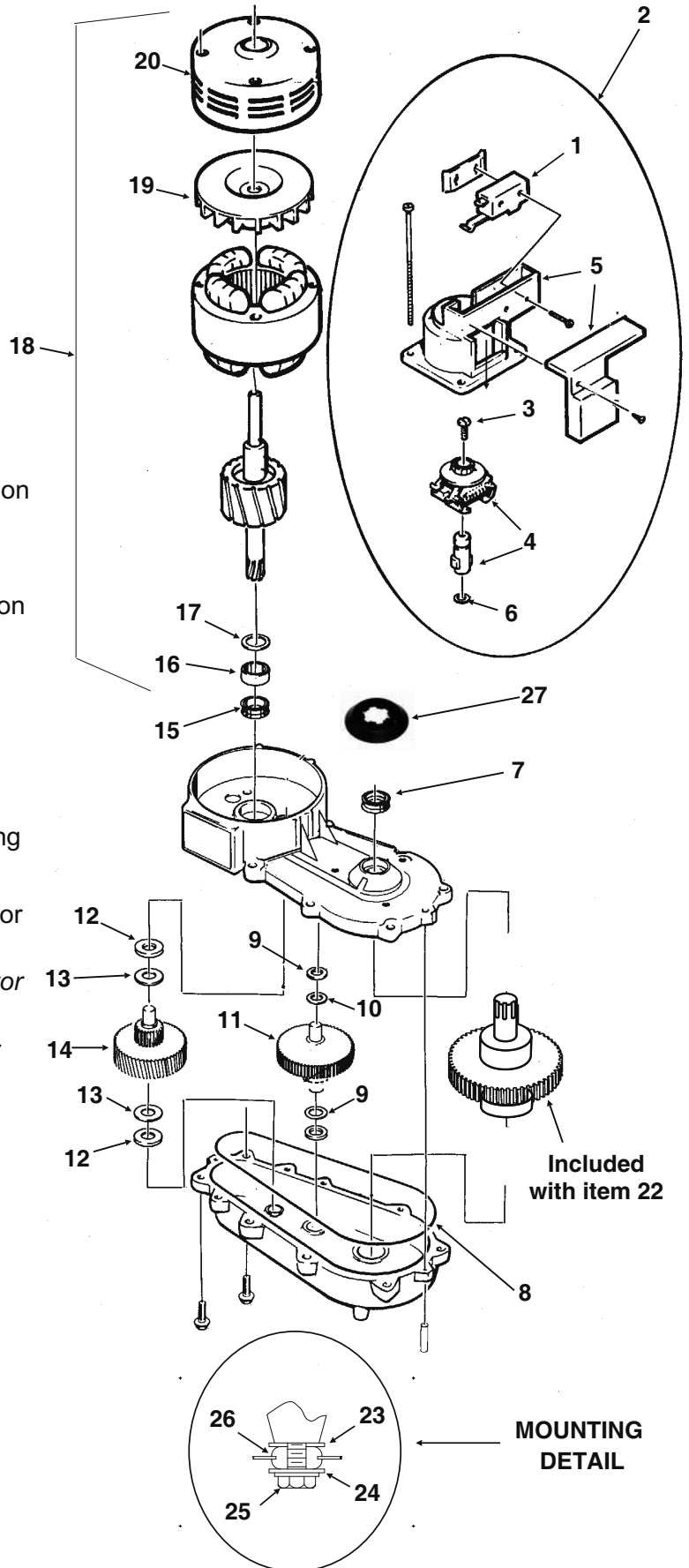

AFE400 SERVICE PARTS

CONTROL BOX

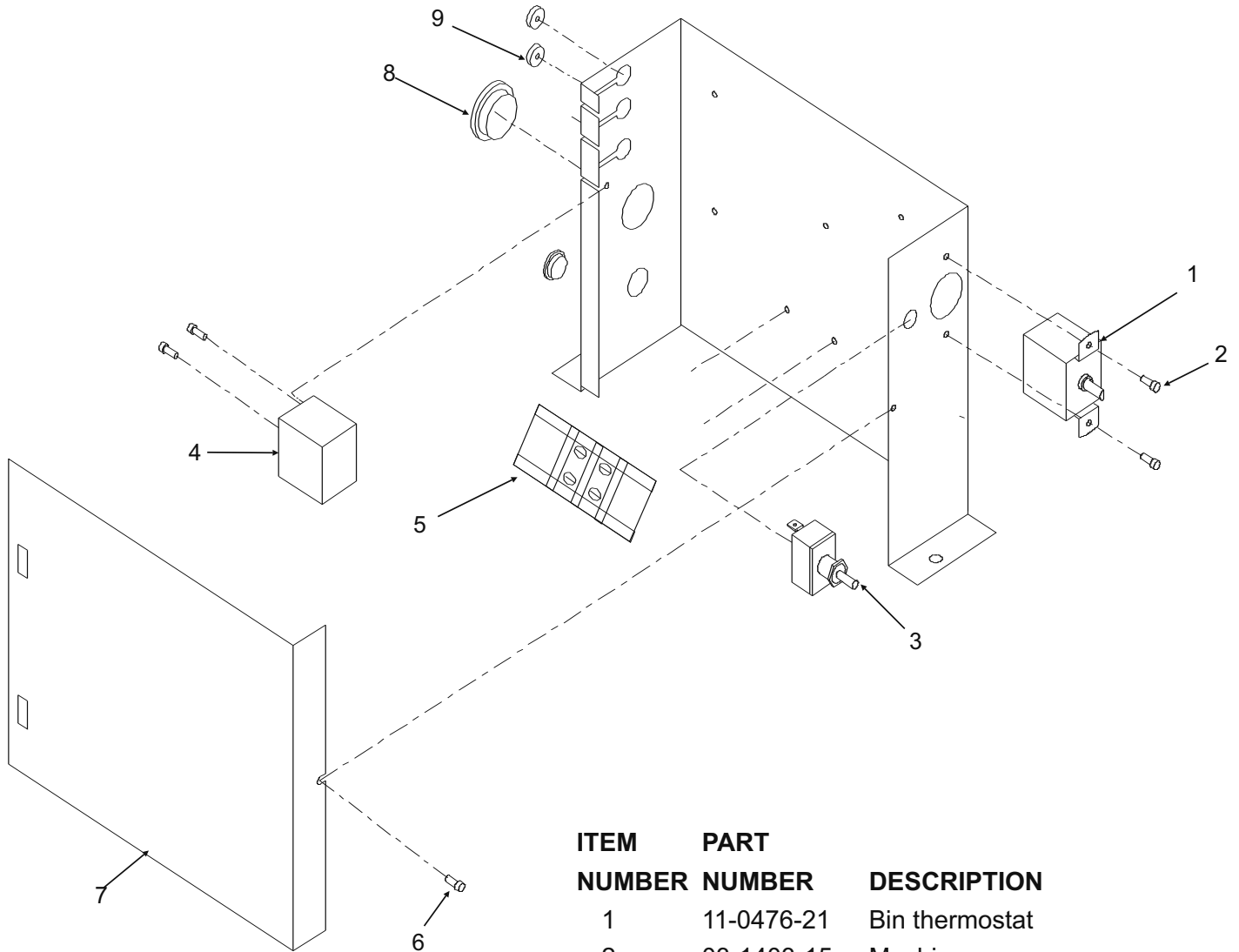

ITEM NUMBER	PART NUMBER	DESCRIPTION
1	11-0476-21	Bin thermostat
2	03-1403-15	Machine screw
3	12-2637-01	Toggle switch, spst
4	11-0402-21	Auger delay control
5	12-0813-04	Terminal block
6	03-1404-29	Sheet metal screw
7	A35273-001	Control box cover
8	12-1213-11	Snap bushing
9	13-0727-00	Grommet

AFE400 SERVICE PARTS SCHEMATIC DIAGRAM

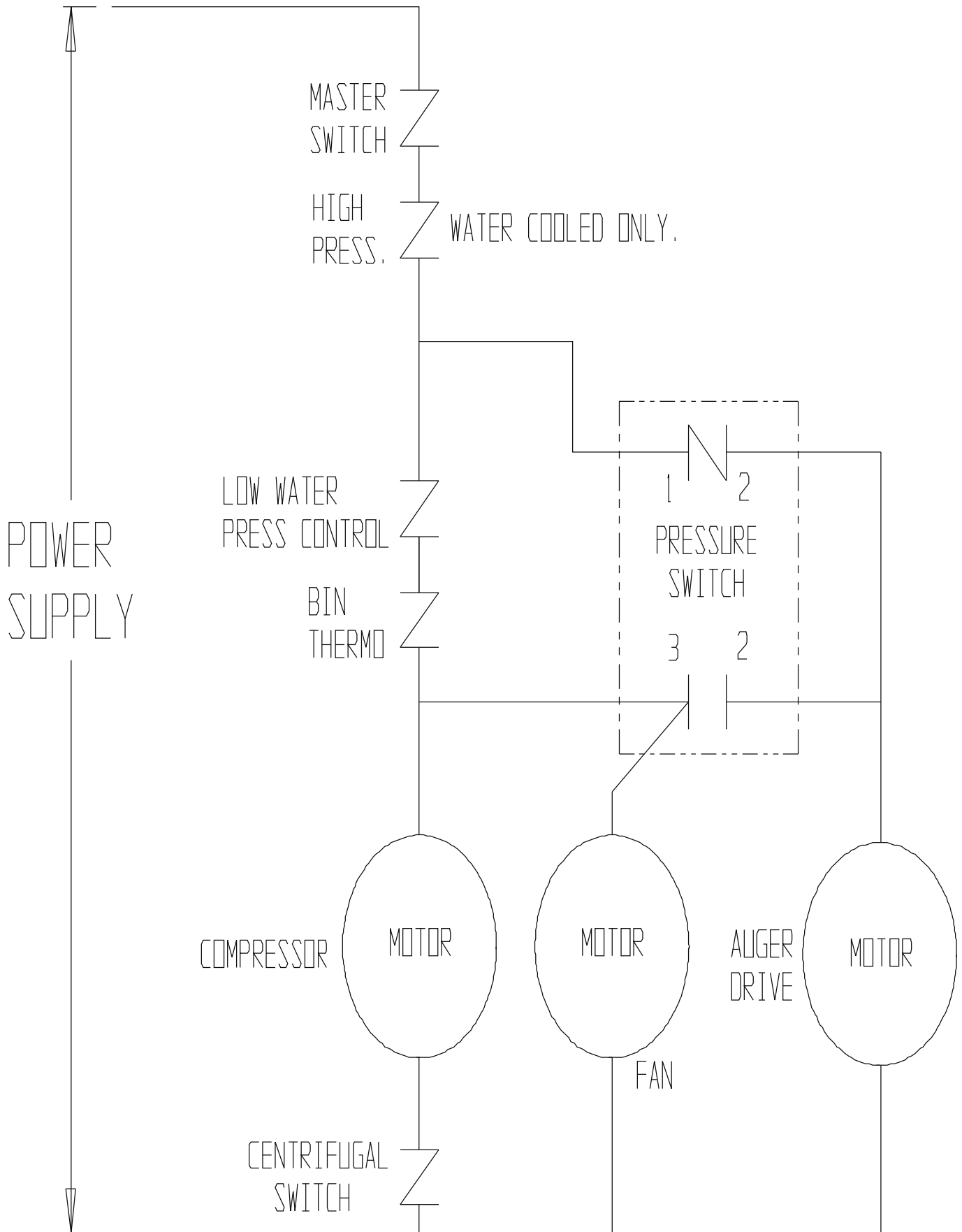

AFE400 SERVICE PARTS WIRING DIAGRAM

A36707-001

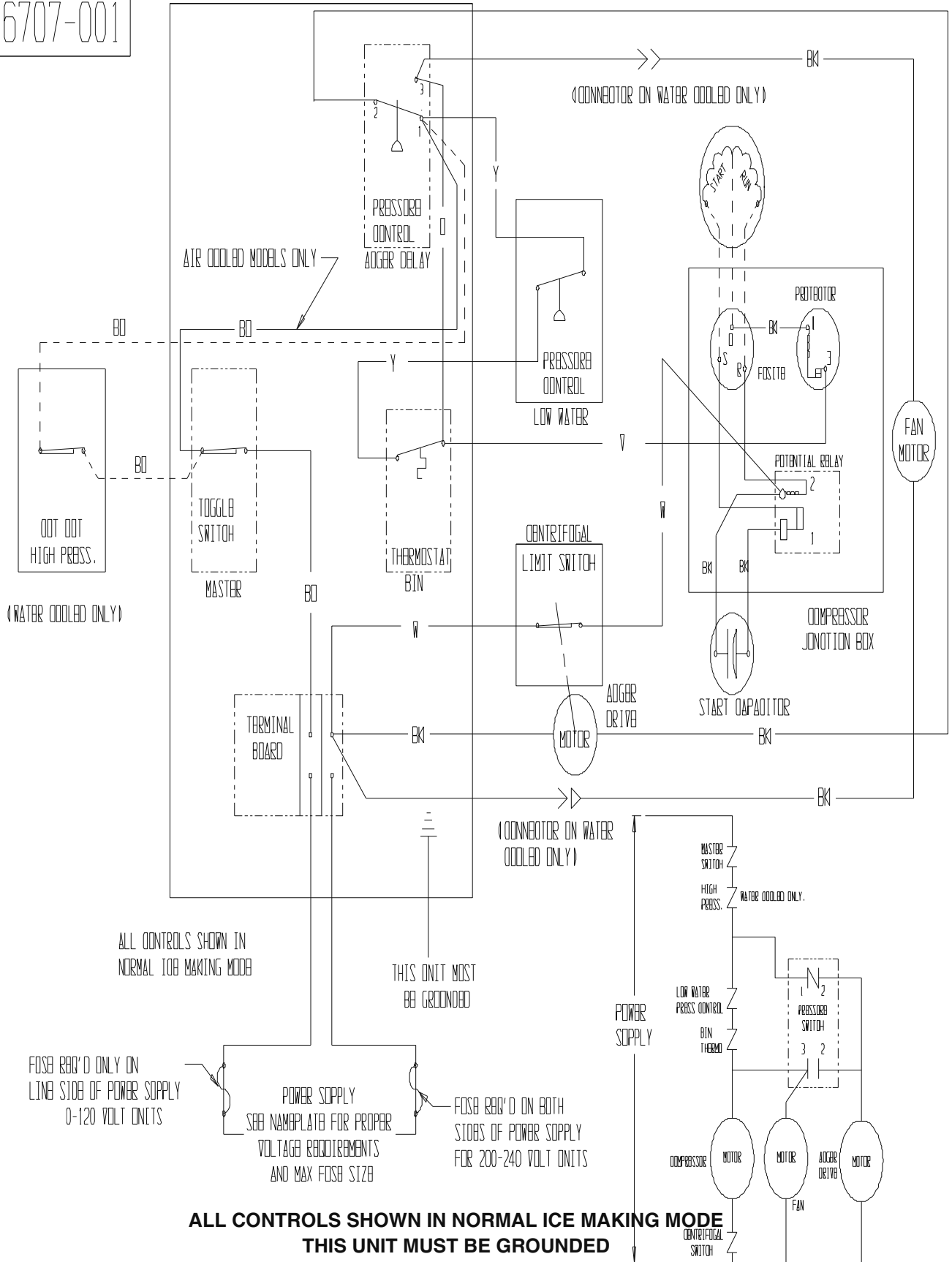

AFE400 SERVICE PARTS

Wiring Diagram, for air cooled units with high pressure cut out

17-3094-01

