

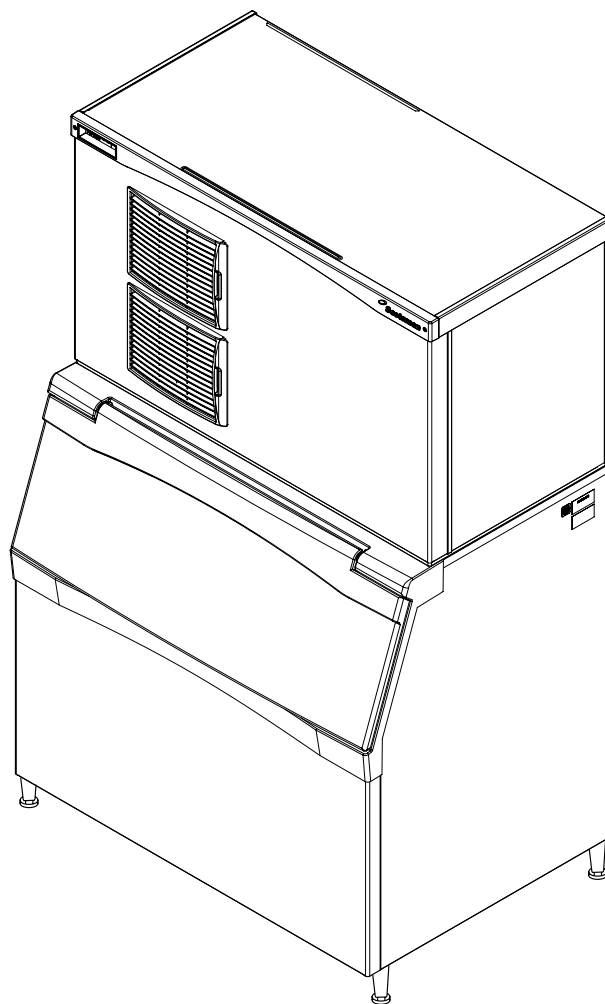

Prodigy Series Modular Cuber Technical Service Manual

**Models C0322, C0522, C0722, C0330, C0530,
C0630, C0830, C1030, C1448, C1848 and
C2148**

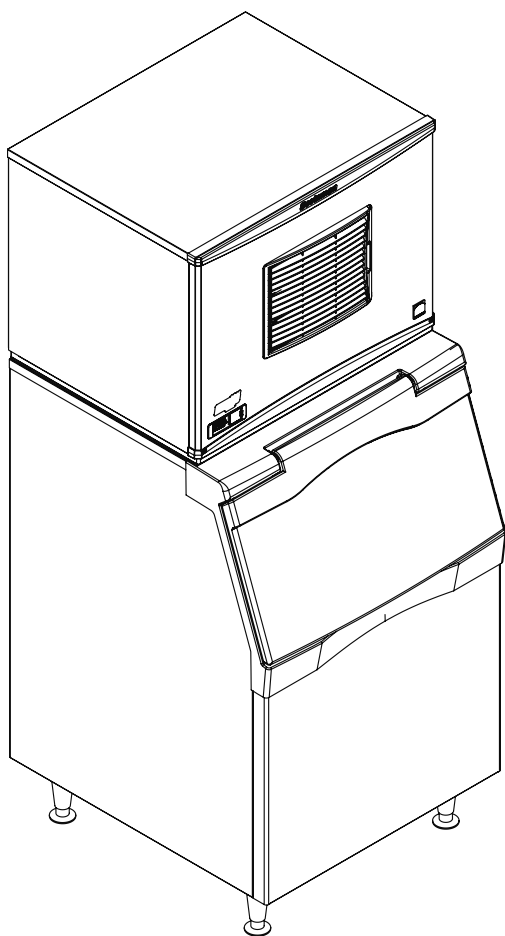

Includes Prodigy Plus D Models

Introduction

This technical manual covers the Prodigy line, excluding the Eclipse remote low side models. All are shipped with an Installation and User's manual, which can be referred to separately. General installation information is included in this manual.

Contents		Critical Maintenance - Spillway	Page 42
Model Number Description	Page 3	Diagnostics – Air Cooled	Page 43
Water	Page 4	Diagnostics - Air Cooled	Page 44
General Installation - Air or Water Cooled	Page 5	Low Ice Making Capacity - Air Cooled.	Page 45
General Installation - Air or Water Cooled	Page 6	Diagnostics – Water Cooled	Page 46
Adjustments.	Page 7	Diagnostics - Water Cooled.	Page 47
Water purge setting	Page 8	Low Ice Making Capacity - Water Cooled	Page 48
General Installation - Remote	Page 9	Diagnostics – Remote Air Cooled	Page 49
General Installation - Remote	Page 10	Diagnostics - Remote Air Cooled.	Page 50
General Installation - Remote	Page 11	Low Ice Making Capacity - Remote Air Cooled.	Page 51
General Installation - Remote	Page 12	Test Procedures - Sensors	Page 52
Pre-Charged Tubing Coupling Connections	Page 13	Ice Thickness Sensor	Page 53
General Installation - Remote	Page 14	Water Level Sensor	Page 54
Prodigy Cuber System Information	Page 15	Temperature Sensors	Page 55
Controller Information	Page 16	Test Procedures - Compressor	Page 56
Component Indicator Lights.	Page 17	Test Procedures - Fan motor	Page 57
How It Works - Air Cooled	Page 18	Test Procedures - Water Pump	Page 58
How It Works - Water Cooled	Page 19	Test Procedure - Purge valve.	Page 59
How It Works - Remote	Page 20	Test Procedure - Compressor contactor	Page 60
Electrical Sequence - Air or Water Cooled	Page 21	Test Procedures - Pressure switches	Page 61
Electrical Sequence - Remote Cooled.	Page 22	Test Procedures - Liquid Line Solenoid	Page 62
Remote Schematics	Page 23	Test Procedure - Inlet Water Solenoid Valve.	Page 63
Electrical Component Details	Page 24	Test Procedure - Harvest Assist	Page 64
Electrical Component Details	Page 26	Performance Data - C0322	Page 65
Refrigeration	Page 27	Performance Data - C0522	Page 66
Water System	Page 28	Performance Data - C0722	Page 67
Control Operation	Page 29	Performance Data - C0330	Page 68
Control Safeties.	Page 30	Performance Data - C0530	Page 69
Control Button Use (from standby)	Page 31	Performance Data - C0630	Page 70
Control Button Use - continued	Page 32	Performance Data - C0830	Page 71
Compressor Electrical Chart	Page 33	Performance Data - C1030	Page 72
Refrigerant Charges and Pressure Switches	Page 34	Performance Data - C1448	Page 73
Compressor Amp Draws	Page 35	Performance Data - C1848	Page 74
Heat Load & Condenser Water GPM	Page 36	Performance Data - C2148	Page 75
Thermistor Values	Page 37	Performance Data Remote - C0522, C0530	Page 76
Cleaning - A, B or C Series	Page 38	Performance Data Remote -	
Cleaning - D Series	Page 39	C0630, C0830, C1030.	Page 77
Critical Maintenance - Water Level Sensor	Page 40	Performance Data Remote - C1448, C1848	Page 78
Critical Maintenance - Ice Thickness Sensor	Page 41		

Wiring Diagrams	Page 79
Wiring Diagrams	Page 80
Wiring Diagrams	Page 81
Wiring Diagrams	Page 82
Wiring Diagrams	Page 83
Wiring Diagrams	Page 84
Wiring Diagrams	Page 85
Wiring Diagrams	Page 86
Wiring Diagrams	Page 87
Wiring Diagrams	Page 88
Wiring Diagrams	Page 89
Wiring Diagrams	Page 90
Wiring Diagrams	Page 91
Repair Section.	Page 92
Repair Section.	Page 93
Repair Section.	Page 94
Repair Section.	Page 95
Repair Section.	Page 96
Repair Section.	Page 97
Repair Section.	Page 98
Repair Section.	Page 99
Refrigeration Removal and Replacement	Page 100
Refrigeration Removal and Replacement	Page 101
Refrigeration Removal and Replacement	Page 102
Optional add-on control information - KVS	Page 103

Model Number Description

Example:

- C0530SA-1D
- C= cuber. CB = Prodigy Advanced Sustainability Cuber, CL=Argentina, CR=Brazil, CA=Asia
- 05= nominal ice capacity in 100s of pounds
- 30= nominal width of cabinet. Other sizes are 22 and 48.
- S= Cube size. S=small or half dice cube. M=medium or full dice cube
- A=Condenser type. A=air cooled. W=water cooled. R = Remote
- -1=Electrical code. -1=115 volts. -32=208-230 single phase. -3=208-230 three phase. -6=230 50 Hz
- D=Series revision code. D=Prodigy Plus

Note: In some areas of this manual model numbers may include only the first five characters of the model number, meaning that the cube size, condenser type and voltage differences are not critical to the information listed there.

Scotsman reserves the right to make design changes and/or improvements at any time. Specifications and design are subject to change without notice.

Water

The quality of the water supplied to the ice machine will have an impact on the time between cleanings and ultimately on the life of the product. There are two ways water can contain impurities: in suspension or in solution. Suspended solids can be filtered out. In solution or dissolved solids cannot be filtered, they must be diluted or treated. Water filters are recommended to remove suspended solids. Some filters have treatment in them for suspended solids. Check with a water treatment service for a recommendation.

RO water. This machine can be supplied with Reverse Osmosis water, but the water conductivity must be no less than 10 microSiemens/cm.

Potential for Airborne Contamination

Installing an ice machine near a source of yeast or similar material can result in the need for more frequent sanitation cleanings due to the tendency of these materials to contaminate the machine. Most water filters remove chlorine from the water supply to the machine which contributes to this situation. Testing has shown that using a filter that does not remove chlorine, such as the Scotsman Aqua Patrol, will greatly improve this situation, while the ice making process itself will remove the chlorine from the ice, resulting in no taste or odor impact.

Additionally, devices intended to enhance ice machine sanitation, such as the Scotsman Aqua Bullet, can be placed in the machine to keep it cleaner between manual cleanings.

Water Purge

Cube ice machines use more water than what ends up in the bin as ice. While most water is used during ice making, a portion is designed to be drained out every cycle to reduce the amount of hard water scale in the machine. That's known as water purge, and an effective purge can increase the time between needed water system cleaning.

In addition, this product has the capability to automatically vary the amount of water purged based on the purity of the water supplied to it. The water purge rate can also be set manually. Adjustments of purge due to local water conditions are not covered by warranty.

General Installation - Air or Water Cooled

Location Limitations:

The product is designed to be installed indoors, in a controlled environment. Air cooled models discharge very warm air into the room out the back. Space must be allowed at the left side and back for air intake and discharge. Water cooled models discharge warm water into the building's drain. Space needs to be provided on both sides and above for service access.

Space Limitations

Note: Although the machine will function, ice capacity of air cooled machines will be significantly reduced with minimal clearance at the sides, back and top. Some space is recommended for service and maintenance purposes on all models.

6" of space at the sides and back is required for adequate operation. To get the most capacity, locate the machine away from heat producing appliances and heating ducts.

22 and 30 inch wide models (up to D series: Airflow is in the left side, out the back (as viewed from the front).

22 and 30 inch D series: Airflow is in the front, out the back

48 inch wide models: Air flow is in the front and left side and out the back.

Environmental Limitations

	Minimum	Maximum
Air temperature	50°F.	100°F.
Water temperature	40°F.	100°F.
Water pressure	20 psi	80 psi

Power supply – acceptable voltage ranges

	Minimum	Maximum
115 volt model	104 volts	126 volts
208-230 volt model	198 volts	253 volts

Warranty Information

The warranty statement for this product is provided separately from this manual. Refer to it for applicable coverage. In general warranty covers defects in material or workmanship. It does not cover maintenance, corrections to installations, or situations when the machine is operated in circumstances that exceed the limitations printed above

General Installation - Air or Water Cooled

Plumbing Requirements

All models require connection to cold, potable water. A hand actuated valve within site of the machine is required. Air cooled models have a single 3/8" FPT inlet water connection.

Water cooled models have the same inlet fitting plus an additional 3/8" FPT condenser inlet water connection.

Water Filters

If connecting to water filtration, filter only the water to the reservoir, not to the condenser. Install a new cartridge if the filters were used with a prior machine.

All models require drain tubing to be attached to them. Air cooled models have a single 3/4" FPT drain fitting in the back of the cabinet. Water cooled models have the same fitting plus an additional 1/2" FPT drain fitting in the back of the cabinet.

Install new tubing when replacing a prior ice machine, as the tubing will have been sized for the old model and might not be correct for this one.

Note: This NSF listed model has a 1" anti-back flow air gap between the water inlet tube end and the highest possible reservoir water level, no back flow device is required for the potable water inlet.

Drain Tubing:

Use rigid drain tubes and route them separately – do not Tee into the bin's drain and, if water cooled, do not Tee the condenser drain into the reservoir or bin drain.

Vent the reservoir drain. A vertical vent at the back of the drain, extended about 8 – 10" will allow the gravity drain to empty and also keep any surges during draining from discharging water out the vent..

Horizontal runs of drain tubing need a 1/4" fall per foot of run for proper draining. Follow all applicable codes.

Electrical

See the spec sheet or User's Manual for Minimum Circuit Ampacity or Maximum Fuse Size ratings.

The machine is not supplied with a power cord, one must either be field installed or the machine hard-wired.

The dataplate on the back of the cabinet details the power requirements, including voltage, phase, minimum circuit ampacity and maximum fuse size. HACR type circuit breakers may be used in place of fuses. Extension cords are not permitted. Use of a licensed electrician is recommended.

Electrical connections are made inside the junction box in the back panel of the ice machine.

Follow all applicable local, state and national codes.

Adjustments

Ice Bridge Thickness

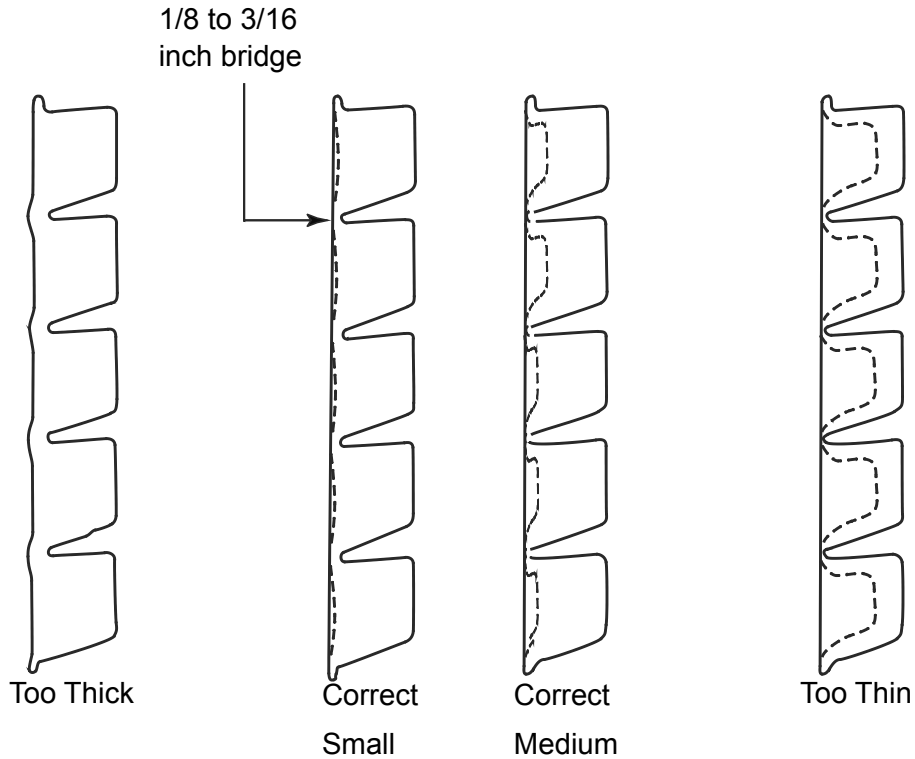

Caution: Do not make the bridge too thin or the machine will not harvest properly. Bridge thickness adjustments are not covered by warranty.

Shut machine off.

Access the ice thickness sensor.

Check gap between metal tip and evaporator grid. Standard gap is 7/32 inch. To set 7/32" drill bit between sensor tip and evaporator to check. Adjust gap using adjustment screw.

Restart unit and check ice bridge. Repeat as needed.

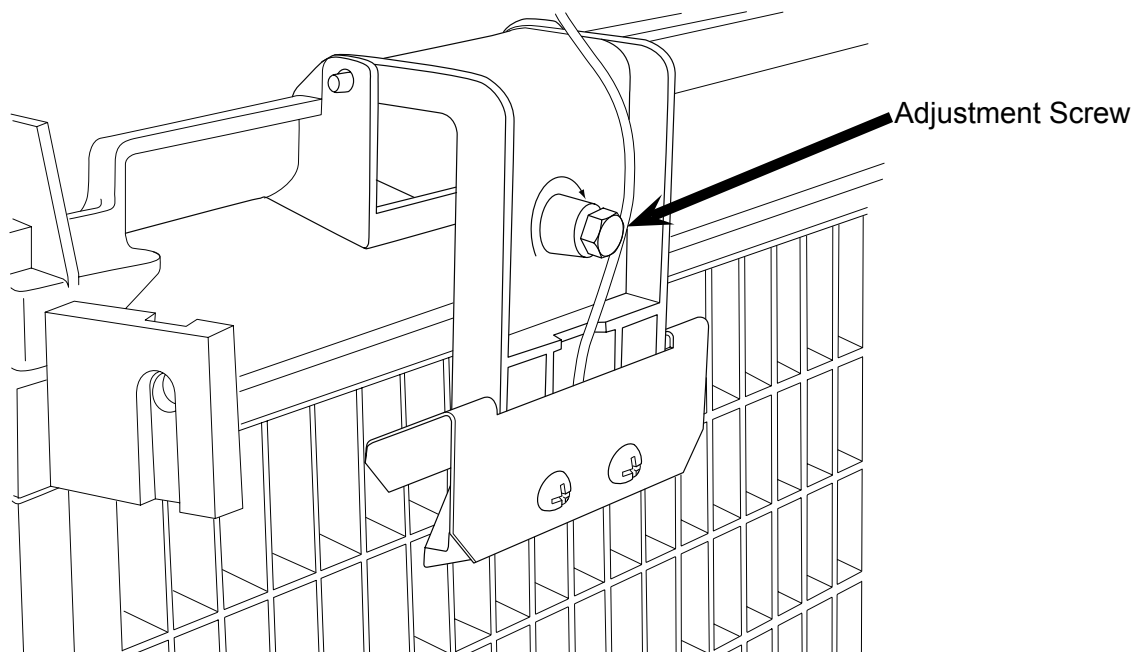

Water purge setting

The water purge is factory set to the Automatic setting. The setting can be changed to one of 5 manual settings or placed on automatic. The purge setting shows in the Code Display.

purge setting	1 - Minimum	2 - Moderate	3 - Standard	4 - Heavy	5 - Maximum	A - Automatic
Water Type	RO water or equivalent, TDS less than 35	Low TDS non - RO water	Setting for typical water	High TDS water	Very high TDS water, greater than 256	Any with conductivity not less than 10 microSiemens/cm

To set:

Switch the machine OFF by holding the Off button in until a number or the letter A shows on the display.

Press and release the On button repeatedly until the number on the display corresponds to the desired setting.

Press and release the Off switch again to return to the normal control state.

Product Description and Electrical Requirements

- See spec sheet or User's Manual for Minimum Circuit Ampacity or Maximum Fuse Size

Dimensions w" x d" x h"	Model	Electrical	Use condenser
22 x 24 x 23	C0522SR-1	115/60/1	ERC111-1
same	same	same	ERC211-1**
30 x 24 x 23	C0530SR-1	115/60/1	ERC111-1
same	same	same	ERC211-1**
same	C0630SR-32	208-230/60/1	ERC311-32
30 x 24 x 29	C0830SR-32	208-230/60/1	ERC311-32
same	C0830SR-3	208-230/60/3	ERC311-32
same	C1030SR-32	208-230/60/1	ERC311-32
same	C1030SR-3	208-230/60/3	ERC311-32
48 x 24 x 29	C1448SR-32	208-230/60/1	ERC311-32
same	C1448SR-3	208-230/60/3	ERC311-32
same	C1848SR-32	208-230/60/1	ERC611-32
same	C1848SR-3	208-230/60/3	ERC611-32
same	C2148SR-32	208-230/60/1	ERC611-32
same	C2148SR-3	208-230/60/3	ERC611-32

** ERC211 has two circuits, when two C0522s or C0530s are connected to it, fan motor relay kit KCMR120 must be used to control the fan motor.

Not all models remain available. C0522 remote and ERC211 are discontinued.

Ratings include the remote condenser motor, as it is designed to be powered by the ice machine. If connecting remote condenser independently of the ice machine, use the information on the condenser's dataplate for fuse and wire sizes.

Table notes: Medium cube models have the same electrical characteristics as Small. Series revision code omitted. All the listed condensers include a headmaster valve.

General Installation - Remote

Location Limitations

This ice system is made up of three parts, the ice making machine, or head; the remote condenser; and the interconnecting tubing. The ice making machine must be installed indoors, in a controlled environment. Space must be provided near the machine for service access. The remote condenser may be installed above or below the ice machine, per the limits stated later in this manual. The remote condenser may be installed outdoors within the temperature limits listed below. The interconnecting tubing must be installed per the directions stated in this manual, and the amount of tubing exposed to uncontrolled temperatures must be minimized.

Space Limitations

Although the machine will function with no clearance to the top and sides, some space must be allowed for service access. Building the machine in with no access will cause higher service cost, in many cases this extra cost may not be covered by warranty.

Environmental Limitations, ice machine:

	Minimum	Maximum
Air temperature	50°F.	100°F.
Water temperature	40°F.	100°F.
Water Pressure	20 psi	80 psi

Environmental Limitations, remote condenser

	Minimum	Maximum
Air temperature	-20°F.	120°F.

Power Supply

	Minimum	Maximum
115 volt model	104 volts	126 volts
208-230 volt model	198 volts	253 volts

Central Condenser Coils

The ice machine may be connected to a central condenser coil. The requirements are:

- Coil – not previously used with mineral oil system. Virgin coil preferred.
- Correct size (internal volume) and capacity (BTUH).
- Includes a headmaster valve for discharge pressure control. Headmaster kit available for certain MAC condensers, kit number is RCKCME6GX.
- Fan motor on all the time or controlled to be on whenever the ice machine is operating.
- Non-Scotsman condensers must have prior Scotsman Engineering approval for warranty coverage to be in effect.

Precharged tubing kits:

The ice making head's and the remote condenser's refrigeration circuits must be connected. They are designed to be connected using precharged refrigerant tubing, supplied in kits of liquid and discharge tubes. Several lengths are available, order the one that just exceeds the length needed for the site.

10" 25' 40' 75'

RTE10 RTE25 RTE40 RTE75

No additional refrigerant is required. Note: Refrigerant charge is supplied with the ice machine

General Installation - Remote

Remote Condenser Location

Use the following for planning the placement of the condenser relative to the ice machine - see illustration on the following page.

Location Limits - condenser location must not exceed ANY of the following limits:

- Maximum rise from the ice machine to the condenser is 35 physical feet
- Maximum drop from the ice machine to the condenser is 15 physical feet
- Physical line set maximum length is 100 feet.
- Calculated line set length maximum is 150.

Calculation Formula:

- Drop = $dd \times 6.6$ (dd = distance in feet)
- Rise = $rd \times 1.7$ (rd = distance in feet)
- Horizontal Run = $hd \times 1$ (hd = distance in feet)
- Calculation: Drop(s) + Rise(s) + Horizontal Run = $dd+rd+hd$ = Calculated Line Length

Configurations that do NOT meet these requirements must receive prior written authorization from Scotsman.

Do NOT:

- Route a line set that rises, then falls, then rises.
- Route a line set that falls, then rises, then falls.

Calculation Example 1:

The condenser is to be located 5 feet below the ice machine and then 20 feet away horizontally.

$5 \text{ feet} \times 6.6 = 33$. $33 + 20 = 53$. This location would be acceptable

Calculation Example 2:

The condenser is to be located 35 feet above and then 100 feet away horizontally. $35 \times 1.7 = 59.5$. $59.5 + 100 = 159.5$. 159.5 is greater than the 150 maximum and is NOT acceptable.

Operating a machine with an unacceptable configuration is misuse and will void the warranty.

General Installation - Remote

For The Installer: Remote Condenser

Locate the condenser as near as possible to the interior location of the ice machine.

Note: The location of the condenser is relative to the ice machine is LIMITED by the specification on the prior page.

Meet all applicable building codes.

Roof Attachment

Install and attach the remote condenser to the roof of the building, using the methods and practices of construction that conform to the local building codes, including having a roofing contractor secure the condenser to the roof.

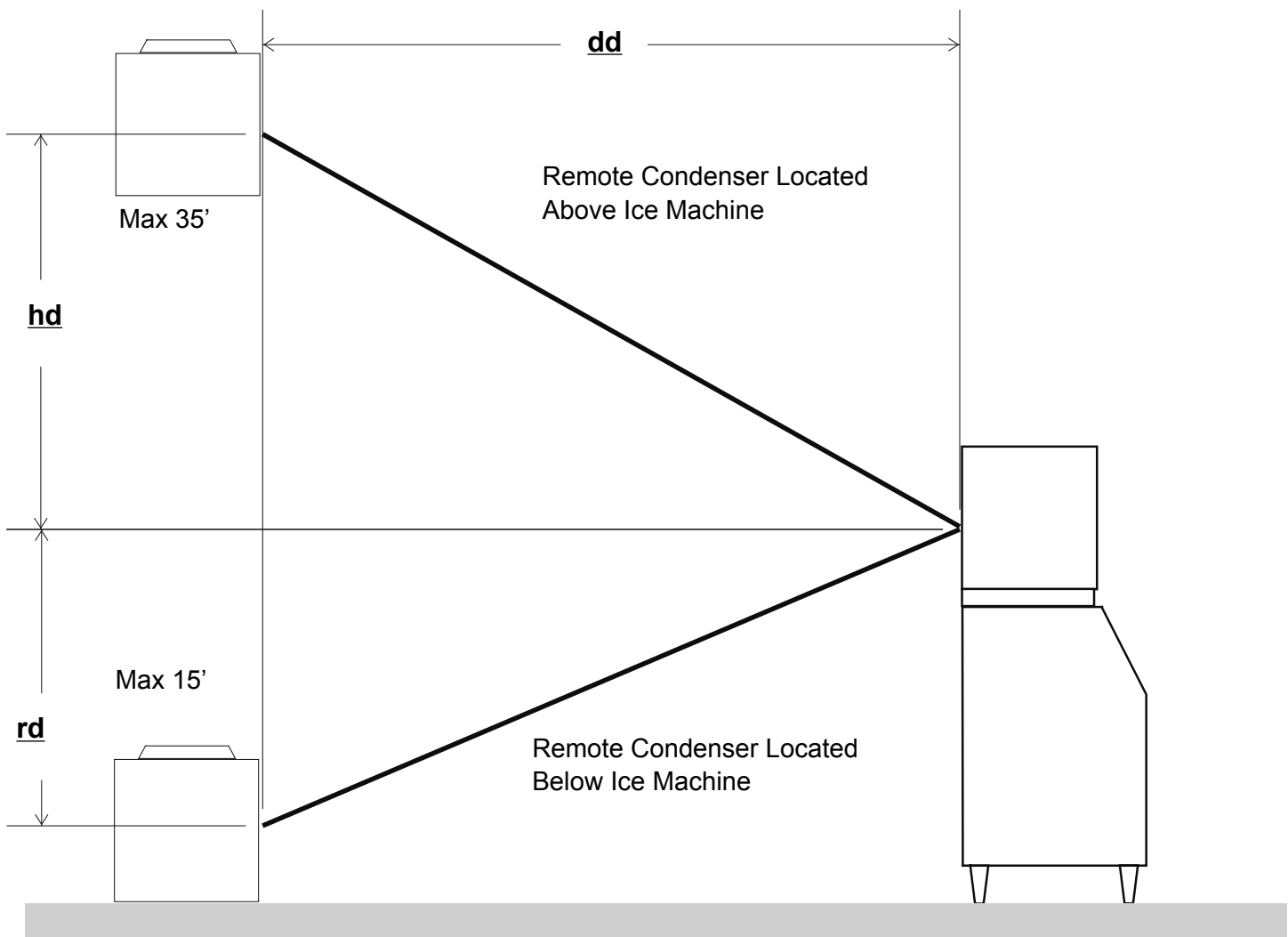

Condenser Distance and Location Schematic

General Installation - Remote

Precharged Line Routing

Do not connect the precharged tubing until all routing and forming of the tubing is complete.

See the Coupling Instructions for final connections.

1. Each set of pre-charged tubing lines contains a 3/8" diameter liquid line, and a 1/2" diameter discharge line.

Note: The openings in the building ceiling or wall, listed in the next step, are the minimum sizes recommended for passing the refrigerant lines through.

2. Have the roofing contractor cut a minimum hole for the refrigerant lines of 2". Check local codes, a separate hole may be required for the electrical power supply to the condenser.

Caution: Do NOT kink the refrigerant tubing while routing it.

3. Route the refrigerant tubes thru the roof opening. Follow straight line routing whenever possible. Excess tubing may EITHER be coiled up INSIDE the building OR cut out prior to connection to the ice maker and condenser. If the excess tubing is cut out, after re-brazing the tubing must be evacuated prior to connection to the ice maker or condenser.

Note brazing requires a nitrogen purge.

If the excess tubing is to be coiled, spiral it horizontally to avoid excess trapping in the lines.

5. Have the roofing contractor seal the holes in the roof per local codes.

Coupling Instructions

The couplings on the ends of the pre-charged line sets are self-sealing when installed properly. Follow these instructions carefully.

These steps must be performed by an EPA Certified Type II or higher technician.

Initial Connections

1. Remove the protector caps and plugs. Wipe the seats and threaded surfaces with a clean cloth to remove any possible foreign matter.

2. Lubricate the inside of the couplings, especially the threads and O-rings, with refrigerant oil.

3. Position the fittings on the correct connections on the condenser and ice machine..

Final Connections:

4a. Begin by tightening the couplings together by hand until it is certain that the threads are properly engaged.

4b. Then using two wrenches tighten the coupling until it bottoms out or a definite increase in resistance is felt.

It is important that ONLY the nut on the pre-charged tube be turned, or the diaphragms will be torn out by the piercing knives and they will be loose in the refrigeration system.

Note: As the couplings are tightened, the diaphragms in the quick connect couplings will begin to be pierced. As that happens, there will be some resistance to tightening the swivel nut.

4c. Continue tightening the swivel nut until it bottoms out or a very definite increase in resistance is felt (no threads should be showing).

5. Use a marker or pen to mark a line on the coupling nut and unit panel. Then tighten the coupling nut an additional one-quarter turn. The line will show the amount that the nut turns.

Do NOT over tighten.

6. After all connections have been made, and after the receiver valve has been opened (open at Initial Start Up), check the couplings for leaks.

Pre-Charged Tubing Coupling Connections

Inspect couplings, wipe clean and lubricate both parts with polyolester refrigerant oil.

Hand tighten to be sure threads are properly engaged.

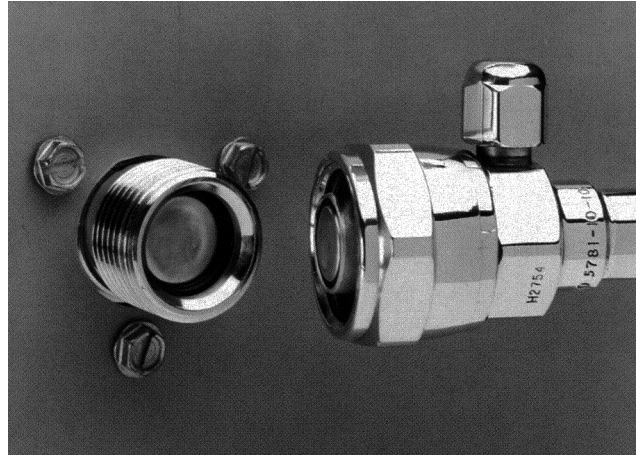

Use two wrenches and continue tightening the couplings. As the diaphragms begin to pierce, the couplings will be harder to turn. Be sure only the swivel nut is rotated.

Continue tightening until the swivel nut feels like it is tight, then go to the next step. No threads will be seen when the couplings are tight.

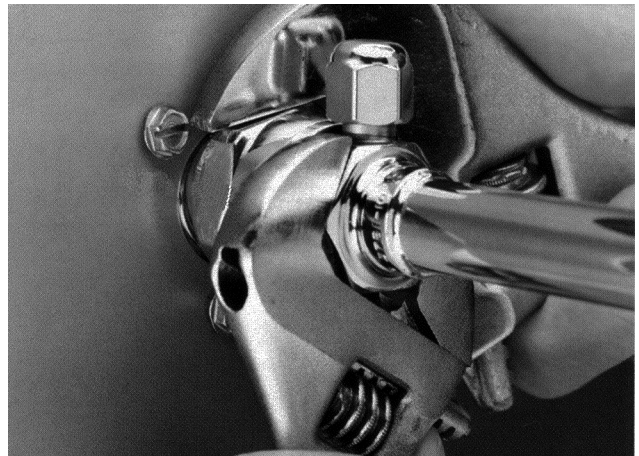

After the swivel nut feels like it is tight, mark the nut and the panel. Then tighten one quarter turn more. That ensures that there is a brass-to-brass joint inside the coupling.

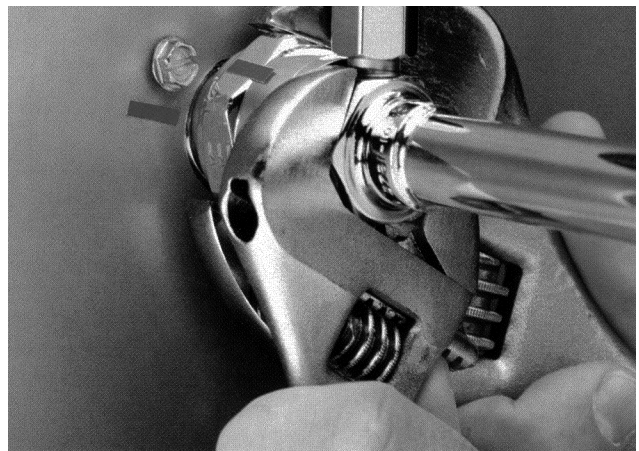

General Installation - Remote

Plumbing Requirements

All models require connection to cold, potable water. A hand actuated valve within site of the machine is required.

Water Filters

Install a new cartridge if the filters were used with a prior machine.

All models require drain tubing to be attached to them. There is a single $\frac{3}{4}$ " FPT drain fitting in the back of the cabinet.

Install new tubing when replacing a prior ice machine, as the tubing will have been sized for the old model and might not be correct for this one.

Connect water supply to water inlet fitting.

Note: This NSF listed model has a 1" anti-back flow air gap between the potable water inlet tube end and the highest possible reservoir water level, no back flow device is required.

Connect drain tubing to drain fitting.

Route the drain tubing to building drain. Follow local codes for drain air gap.

Use rigid drain tubes and route them separately – do not Tee into the bin's drain.

Vent the reservoir drain. A vertical vent at the back of the drain, extended about 8 – 10" will allow the gravity drain to empty and also keep any surges during draining from discharging water.

Horizontal runs of drain tubing need a $\frac{1}{4}$ " per fall per foot of run for proper draining.

Follow all applicable codes.

Electrical

The machine is not supplied with a power cord, one must either be field installed or the machine hard-wired.

The dataplate on the back of the cabinet details the power requirements, including voltage, phase, minimum circuit ampacity and maximum fuse size. HACR type circuit breakers may be used in place of fuses. Extension cords are not permitted. Use of a licensed electrician is recommended.

The ice maker is designed to operate on its own electrical circuit and must be individually fused. Voltage variation must not exceed the limits listed earlier.

The remote condenser is designed to be powered from the ice machine. A separate knockout hole has been provided in the ice maker electrical junction box.

Electrical connections are made inside the junction box in the back panel of the ice machine.

Remove the junction box cover and route the power cord through the access hole and properly attach the power supply wires to the leads in the junction box.

Attach the remote condenser fan motor wires to the wires in the junction box tagged "fan motor leads".

Install field supplied strain reliefs per code. Attach a ground wire to the ground connection in the junction box.

Check voltage when complete.

Return the junction box cover to its original position and secure with the original screws.

Follow all applicable local, state and national codes.

Prodigy Cuber System Information

Overall System Type:

- Refrigeration: Mechanical, either air cooled, water cooled or remote cooled.
- Water System: Inlet water solenoid valve fills reservoir once per cycle. Purge solenoid valve opens to discharge some reservoir water once per cycle.
- Control System: Electronic
- Harvest cycle sensor: Conductivity probe
- Water full/empty sensor: Conductivity probe
- Bin Control: Curtain Switch
- Ice type: Unified
- Harvest system: Hot gas defrost with mechanical assist

Electrical Components:

- Compressor
- Contactor
- Water Pump
- Inlet Water Solenoid Valve
- Purge or purge Valve
- Fan Motor(s)
- Fan motor pressure control
- High pressure cut out – certain AC models only
- Harvest Assist Solenoid(s)
- Hot Gas Valve(s)
- Controller
- Transformer – 12v AC for the controller only
- Water Level Sensor
- Ice Thickness Sensor
- Curtain Switch(es)

Controller Information

Machine Indicator Lights

- Power
- Status
- Water
- Clean

Code Display

Main codes - automatically displayed

F Freeze Cycle

F flashes . . Freeze Cycle is Pending

H Harvest Cycle

H flashes . . Manual Harvest

b Binis Full

C Clean Cycle

L Board Locked

d Test Mode

O Off

E Self Test Failed

1 flashes . . Max Freeze - Retrying

1 Max Freeze Time Shut Down

2 flashes . . Max Harvest - Retrying

2 Max Harvest Time Shut Down

3 Slow Water Fill

4 High Discharge Temp

5 Sump Temp Sensor Failure

7 Discharge Temp Sensor Failure

8 flashes . . Short Freeze - Retrying

8 Short Freeze - Thin ice

Setting Codes - requires push button sequence

Water Purge Settings

A, 1, 2, 3, 4, 5

De-Scale notification

- see table to the right

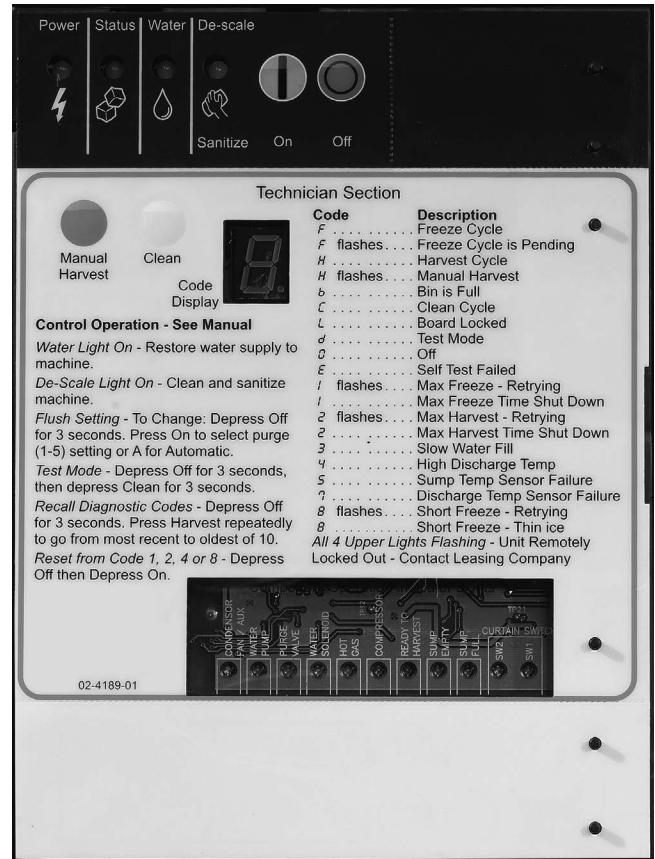

Change De-Scale Notification Interval -

This feature is accessible only from standby (Status Light Off).

1. Press and hold harvest button for 3 seconds.

This starts the Time to Clean Adjustment Mode and displays the current time to clean setting.

2. Press the clean button repeatedly to cycle through the 4 settings:

Prior	Effective 11/6/08
3 months	1 year
4 months	0 or disabled
5 months	4 months
6 months (default)	6 months (default)

3. Push Off to confirm the selection.

Component Indicator Lights

- Condenser Fan / Aux (Aux = liquid line solenoid when a remote condenser model)
- Water Pump
- Purge Valve
- Water Solenoid
- Hot Gas
- Compressor
- Ready to Harvest
- Sump Empty
- Sump Full
- Curtain SW1
- Curtain SW2

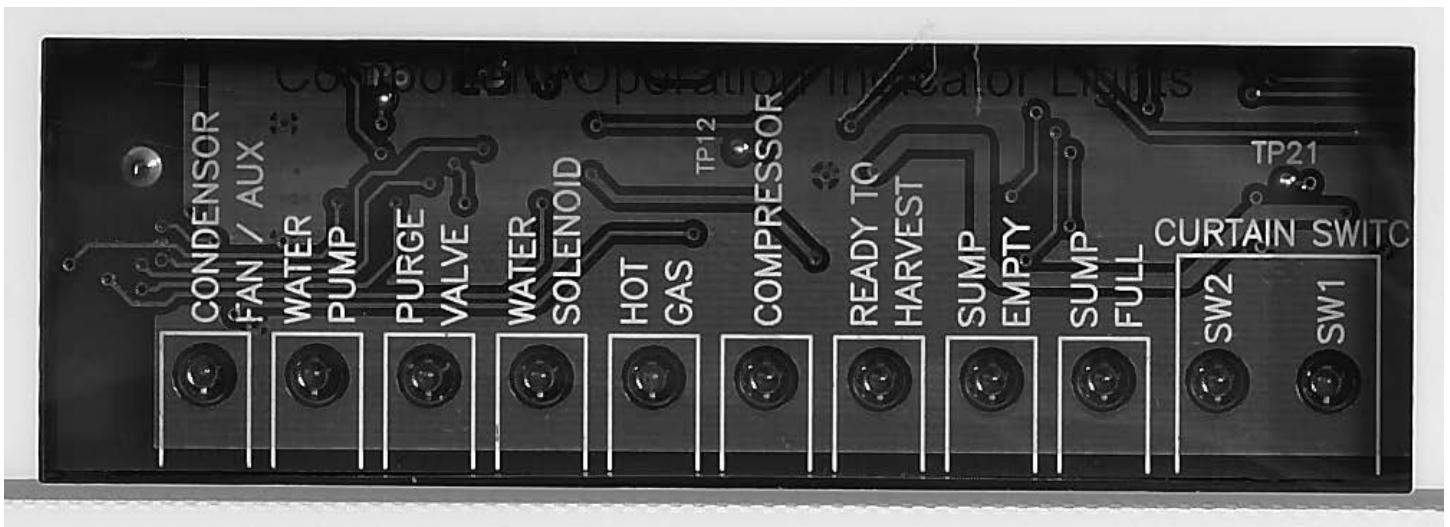

How It Works - Air Cooled

Freeze Cycle. At start up the controller drains and refills the reservoir. The reservoir refills when the mid length water level sensor probe is uncovered and continues to fill until the top probe is in contact with water. When the reservoir has filled, the compressor and water pump start. After the discharge pressure has increased past the cut in point of the fan pressure control, the fan motor(s) will begin to operate and warm air will be discharged out the back of the cabinet. The fan motor will switch on and off as the discharge pressure rises and falls.

Water flows over the evaporator as the refrigeration system begins to remove heat. When the water temperature falls to a preset point, as measured by the water temperature sensor, the controller shuts off the water pump for 30 seconds. The freeze cycle resumes when the pump restarts and ice begins to form on the evaporator. As it forms, the water flowing over the ice moves closer and closer to the metal tip of the ice thickness sensor. When it comes into contact with the sensor for a few continuous seconds, that signals the controller that the freeze cycle is complete.

The controller may shut the air cooled fan motor off for a variable period of time to build up heat for harvest. This is dependant upon the temperature of the discharge line sensor.

Harvest Cycle. When the harvest cycle begins, the controller shuts off the fan motor, switches on the hot gas valve, and through a parallel circuit, the harvest assist solenoid. After a few seconds the purge valve opens and water is drained from the reservoir. Based on either the automatic purge or manual purge setting, the pump and purge valve will be switched off at a time determined to have drained enough water for that setting. The inlet water valve will open to fill the reservoir anytime the mid length probe is uncovered, which occurs during the reservoir drain cycle. Harvest continues as the hot discharge gas flows into the evaporator serpentine, heating up the evaporator. At the same time the harvest assist solenoid is pushing against the back of the ice slab. When the ice releases from the evaporator, it harvests as a unit, and the harvest assist probe provides some additional force to push it off. When the ice falls off it will force the curtain(s) open. An open curtain during the harvest cycle signals the controller that the evaporator has released its ice. If this is a single evaporator machine the controller will terminate harvest. If it is a two evaporator machine, the controller will continue harvest until both curtains have opened. If one curtain remains open, the controller will shut the machine down on bin full. Anytime harvest is complete the hot gas valve and harvest assist are shut off. The harvest assist pin returns to its normal position by spring pressure.

If the curtain(s) re-close after harvest, the freeze cycle will restart.

How It Works - Water Cooled

Freeze Cycle. At start up the controller drains and refills the reservoir. The reservoir refills when the mid length water level sensor probe is uncovered and continues to fill until the top probe is in contact with water. When the reservoir has filled, the compressor and water pump start. After the discharge pressure has increased past the set point of the water regulating valve, the water regulating valve will open and warm water will be discharged out the condenser drain. The water regulating valve will modulate to maintain a relatively constant discharge pressure. Water flows over the evaporator as the refrigeration system begins to remove heat. When the water temperature falls to a preset point, as measured by the water temperature sensor, the controller shuts off the water pump for 30 seconds. The freeze cycle resumes when the pump restarts and ice begins to form on the evaporator. As it forms, the water flowing over the ice moves closer and closer to the metal tip of the ice thickness sensor. When it comes into contact with the sensor for a few continuous seconds, that signals the controller that the freeze cycle is complete.

Harvest Cycle. When the harvest cycle begins, the controller switches on the hot gas valve, and through a parallel circuit, the harvest assist solenoid. After a few seconds the purge valve opens and water is drained from the reservoir. Based on either the automatic purge or manual purge setting, the pump and purge valve will be switched off at a time determined to have drained enough water for that setting. The inlet water valve will open to fill the reservoir anytime the mid length probe is uncovered, which occurs during the reservoir drain cycle.

Harvest continues as the hot discharge gas flows into the evaporator serpentine, heating up the evaporator. At the same time the harvest assist solenoid is pushing against the back of the ice slab. When the ice releases from the evaporator, it harvests as a unit, and the harvest assist probe provides some additional force to push it off. When the ice falls off it will force the curtain(s) open. An open curtain during the harvest cycle signals the controller that the evaporator has released its ice. If this is a single evaporator machine the controller will terminate harvest. If it is a two evaporator machine, the controller will continue harvest until both curtains have opened. If a curtain remains open, the controller will shut the machine down on bin full. Anytime harvest is complete the hot gas valve and harvest assist are shut off. The harvest assist pin returns to its normal position by spring pressure.

If the curtain(s) re-close after harvest, the freeze cycle will restart.

How It Works - Remote

Freeze Cycle. At start up the controller drains and refills the reservoir. The reservoir refills when the mid length water level sensor probe is uncovered and continues to fill until the top probe is in contact with water. When the reservoir has filled, the liquid line valve, compressor and water pump are switched on. After the discharge pressure has increased past the set point of the headmaster in the condenser, the headmaster will direct refrigerant gas into the condenser and warm air will be discharged out of the condenser. The headmaster will modulate to maintain a minimum discharge pressure. Water flows over the evaporator as the refrigeration system begins to remove heat. When the water temperature falls to a preset point, as measured by the water temperature sensor, the controller shuts off the water pump for 30 seconds. The freeze cycle resumes when the pump restarts and ice begins to form on the evaporator. As it forms, the water flowing over the ice moves closer and closer to the metal tip of the ice thickness sensor. When it comes into contact with the sensor for a few continuous seconds, that signals the controller that the freeze cycle is complete.

Harvest Cycle. When the harvest cycle begins, the controller switches on the hot gas valve, and through a parallel circuit, the harvest assist solenoid. After a few seconds the purge valve opens and water is drained from the reservoir. Based on either the automatic purge or manual purge setting, the pump and purge valve will be switched off at a time determined to have drained enough water for that setting. The inlet water valve will open to fill the reservoir anytime the mid length probe is uncovered, which occurs during the reservoir drain cycle.

Harvest continues as the hot discharge gas flows into the evaporator serpentine, heating up the evaporator. At the same time the harvest assist solenoid is pushing against the back of the ice slab. When the ice releases from the evaporator, it harvests as a unit, and the harvest assist probe provides some additional force to push it off. When the ice falls off it will force the curtain(s) open. An open curtain during the harvest cycle signals the controller that the evaporator has released its ice. If this is a single evaporator machine the controller will terminate harvest. If it is a two evaporator machine, the controller will continue harvest until both curtains have opened. If a curtain remains open, the controller will shut the machine down. Anytime harvest is complete the hot gas valve and harvest assist are shut off.

The harvest assist pin returns to its normal position by spring pressure.

If the curtain(s) re-close after harvest, the freeze cycle will restart.

Shut down occurs when a curtain remains open after a harvest cycle. The controller will switch off the liquid line solenoid valve and operate the compressor for 30 seconds, then shut it off.

Electrical Sequence - Air or Water Cooled

Power connected, unit previously switched Off.

Control board does a self check. If the self check fails, the unit displays an E and no further action will occur.

If the self check passes, the controller will display a 0, the curtain light(s) will be ON and the Power and Sump Empty lights will be ON.

Pushing and releasing the On button will start the ice making process.

The display will begin to blink F. The component indicator lights will switch on and off to match the following process:

The purge valve opens and the water pump starts to empty the reservoir. This is done to discharge any excess water from ice melting into the reservoir.

The hot gas valve and the harvest assist solenoid are energized.

The inlet water valve will open to fill the reservoir. The water valve can open any time the water level is low.

After a few seconds the purge valve closes and the pump shuts off.

When the reservoir is full the inlet water valve stops and the compressor switches on. Five seconds after the compressor starts the hot gas valve and the harvest assist solenoid are de-energized.

Light Information: The display shows a non-blinking F. The Power and Status Lights will be Green. The compressor, fan motor, water pump, sump full and one or two curtain switch lights will be ON.

The air cooled model's fan motor will start to turn when the discharge pressure has built up to the fan pressure control's cut in point. This is about 15 seconds after the compressor starts.

The Freeze cycle continues. The compressor, water pump, fan motor and curtain indicator lights will be ON. When the reservoir water temperature falls to a certain preset point, the water pump will shut off for 30 seconds. This is the anti-slush period. At this time the controller checks the conductivity of the water in the reservoir for the auto-purge feature. After the water pump restarts the Sump Full light will go out and neither sump lights will be on for the rest of the freeze cycle.

When the ice has built up enough so that the water flowing over the evaporator comes into continuous contact with the ice level sensor, the Ready to Harvest light will begin to blink on and off. When it has been On continuously for 5 seconds, the controller will switch the machine into a Harvest cycle.

Indicator Information: The display shows a non-blinking H. The Power and Status Lights will be Green. The compressor, hot gas valve and one or two curtain switch lights will be ON. After a few seconds the water pump, purge valve and inlet water valve lights will come on.

The fan motor(s) shut off and remain off throughout the harvest cycle.

The harvest assist solenoid is connected in parallel with the hot gas valve. Although it is energized throughout the harvest cycle, its piston does not move until the ice has become partially loosened from the evaporator plate by the action of the hot refrigerant gas passing through the evaporator serpentine.

The water pump and purge valve will shut off when the purge level setting time has been reached, either the manual time or the automatic time. The inlet water valve will remain on until it fills the reservoir. The Ready to Harvest light will switch Off when the ice falls from the evaporator.

Harvest continues until the ice slab is ejected from the evaporator and falls, opening the curtain. When the curtain opens, the magnetic reed curtain switch opens, breaking the circuit to the controller. If the curtain re-closes within 30 seconds, the controller switches the machine back into another freeze cycle. If the curtain switch remains open, the controller shuts the machine down and puts it into a standby position.

Electrical Sequence - Remote Cooled

Power connected, unit previously switched Off.

Control board does a self check. If the self check fails, the unit displays an E and no further action will occur.

If the self check passes, the controller will display a 0, the curtain light(s) will be ON and the Power and Sump Empty lights will be ON.

Pushing and releasing the On button will start the ice making process.

The display will begin to blink F. The component indicator lights will switch on and off to match the following process:

The purge valve opens and the water pump starts to empty the reservoir. This is done to discharge any excess water from ice melting into the reservoir.

The hot gas valve and the harvest assist solenoid are energized.

The inlet water valve will open to fill the reservoir. The water valve can open any time the water level is low.

After a few seconds the purge valve closes and the pump shuts off.

When the reservoir is full the inlet water valve stops, the liquid line valve is opened and the compressor switches on. Five seconds after the compressor starts the hot gas valve and the harvest assist solenoid are de-energized.

Light Information: The display shows a non-blinking F. The Power and Status Lights will be Green. The compressor, fan motor, water pump, sump full and one or two curtain switch lights will be ON.

The Freeze cycle continues. When the reservoir water temperature falls to a certain preset point, the water pump will shut off for 30 seconds. This is the anti-slush period. At this time the controller checks the conductivity of the water in the reservoir for the auto-purge feature. After the water pump restarts the Sump Full light will go out and neither sump lights will be on for the rest of the freeze cycle.

When the ice has built up enough so that the water flowing over the evaporator comes into continuous contact with the ice level sensor, the Ready to Harvest light will begin to blink on and off. When it has been On continuously for 3 seconds, the controller will switch the machine into a Harvest cycle. Indicator Information: The display shows a non-blinking H. The Power and Status Lights will be Green.

The compressor, hot gas valve and one or two curtain switch lights will be ON. After a few seconds the water pump, purge valve and inlet water valve lights will come on. The harvest assist solenoid is connected in parallel with the hot gas valve. Although it is energized throughout the harvest cycle, its piston does not move until the ice has become partially loosened from the evaporator plate by the action of the hot refrigerant gas passing through the evaporator serpentine.

The remote condenser fan motor is powered by the compressor contactor, so it will be operating during the harvest cycle.

The water pump and purge valve will shut off when the purge level setting time has been reached, either the manual time or the automatic time. The inlet water valve will remain on until it fills the reservoir. The Ready to Harvest light will switch Off when the ice falls from the evaporator.

Harvest continues until the ice slab is ejected from the evaporator and falls, opening the curtain. When the curtain opens, the magnetic reed curtain switch opens, breaking the circuit to the controller. If the curtain re-closes within 30 seconds, the controller switches the machine back into another freeze cycle. If the curtain switch remains open, the controller shuts the machine down and puts it into a standby position.

Remote Schematics

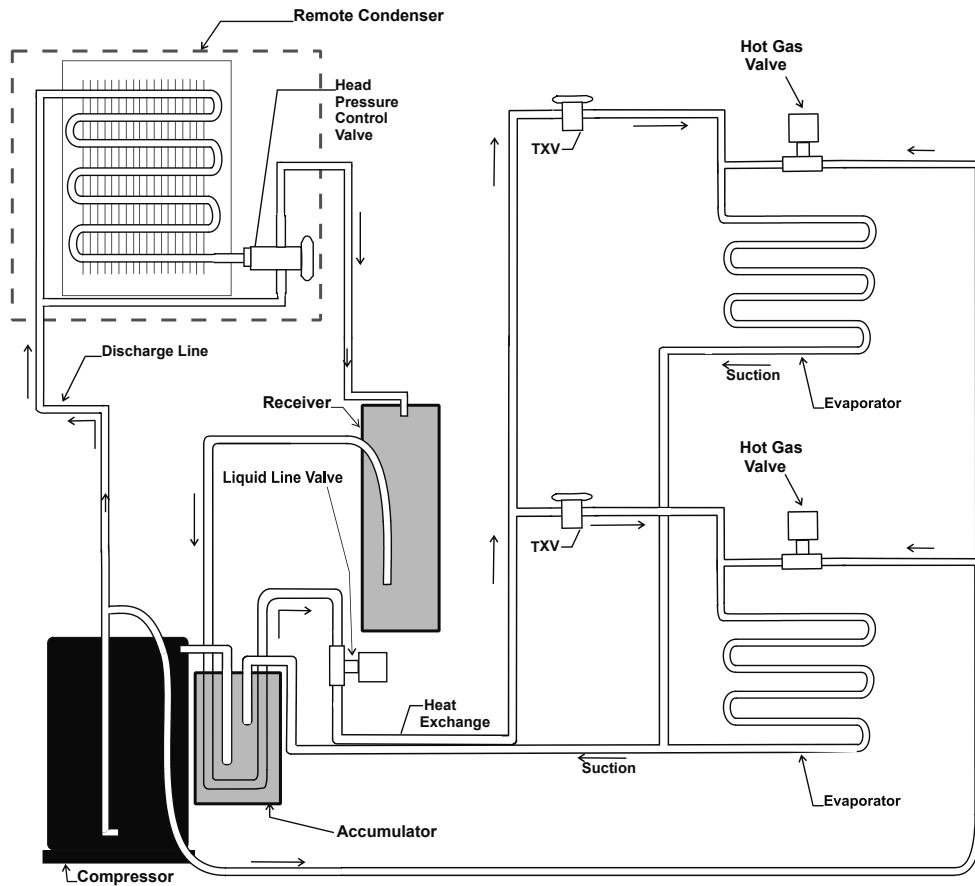
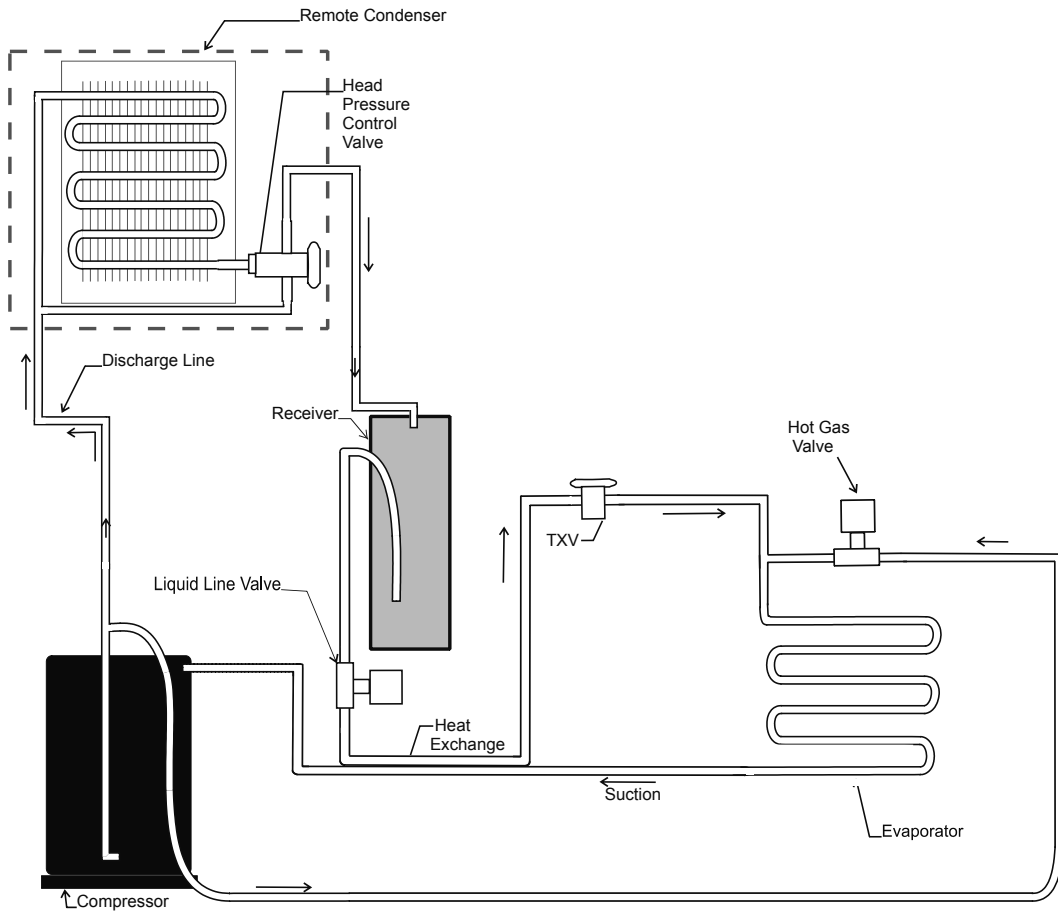

Electrical Component Details

Compressor

- Operated by the compressor contactor. Single phase self contained models have PTCR and run capacitor.

Contactor

- Operated by the controller and the high pressure cut out switch. Line voltage coil. When energized the Compressor indicator light will be ON.

Water Pump

- Operated by the controller. When energized, the Water Pump indicator light will be ON. Inlet Water Solenoid Valve
- Operated by the controller. Line voltage coil. When energized, the Water Solenoid indicator light will be ON.

Purge Valve

- Operated by the controller. Line voltage coil. When energized, the Purge Valve indicator light will be ON. Energized for a time during harvest.

Fan Motor(s)

- Operated by the controller and the fan pressure control. Can cycle on and off in the freeze cycle, always off during harvest. When the controller has energized it, the indicator light will be ON but the fan will not turn unless the discharge pressure is high enough to close the high pressure control.
- Fan(s) may shut off near the end of the freeze cycle to build up heat for harvest. Time of shut off depends upon available heat, as measured by the discharge temperature.

High pressure cut out

- Some air cooled and all remote and all water cooled models have a high pressure cut out switch that shuts the power off to the compressor contactor if the discharge pressure is too high. It is an automatic reset.

Harvest Assist Solenoid or Motor(s)

- Operated by the controller in parallel with the hot gas valve. Cycles on and off at the beginning of a restart. Energized throughout the harvest cycle. Line voltage coil.

Electrical Component Details

Liquid Line Valve

- Remote only. Opened by the controller to start a freeze cycle. Closed to shut unit off. Line voltage coil.

Hot Gas Valve(s)

- Operated by the controller in parallel with the harvest assist solenoid. Cycles on and off at the beginning of a restart. Energized throughout the harvest cycle. Line voltage coil.

Controller

- Senses ice thickness, water level, water temperature, discharge temperature. Controls compressor contactor, fan motor, water pump, inlet water valve, hot gas valve, purge valve, harvest assist solenoid. Indicates status and component operation. 12 volt.

Transformer

- 12 volt secondary, supplies power to controller only.

Water Level Sensor

- Three probe conductivity sensor. Bottom probe is common, mid probe is refill sump, top probe is full sump. Refill can occur at any time.

Ice Thickness Sensor

- Single wire conductivity sensor. Circuit made from controller to ground to controller when water contacts a probe suspended over ice plate. Signals ready for harvest.

Curtain Switch(es)

- Magnetic reed switch. Normally open, switch is closed when magnet is nearby. Models with two evaporators have two curtain switches. Single switch can be connected to either J8 or J7 of controller. Curtains may be removed in the freeze cycle without affecting controller operation. A curtain removed during harvest will cause the controller to terminate harvest and shut the unit off. Two curtain models require both curtains to open to terminate harvest, and if either one remains open for 30 seconds that signals the controller to shut the unit off on bin full.

Water temperature sensor.

- Thermistor inserted into the water pump discharge hose. Reported temperature used by the controller to determine anti-slush cycle start time.

Electrical Component Details

Discharge temperature sensor.

• Thermistor attached to the discharge line near the compressor. Reported temperature used by the controller to determine end-of-cycle-fan-off-delay time. If discharge temperature exceeds a preset maximum, controller will shut the machine off.

Note: Controller will operate machine in a default mode with thermistors disconnected from the controller. Diagnostic code #5 or 7 will be displayed during that time.

Component Indicator Lights

System

Indicator Light ON

Condenser Fan or Liquid Line Valve

Fan Motor Powered or LLV open

Water Pump

Pump Motor Powered

Purge Valve

Purge Valve Opens

Inlet Water Solenoid Valve

Inlet Water Valve Opens

Hot Gas

Hot Gas Valve Opens

Compressor Contactor

Contactor Closes

Ready to Harvest

Water contacting ice thickness sensor probe

Sump Empty

Open between mid sensor and common

Sump Full

Closed between top probe and mid probe

Curtain Switch

Curtain open

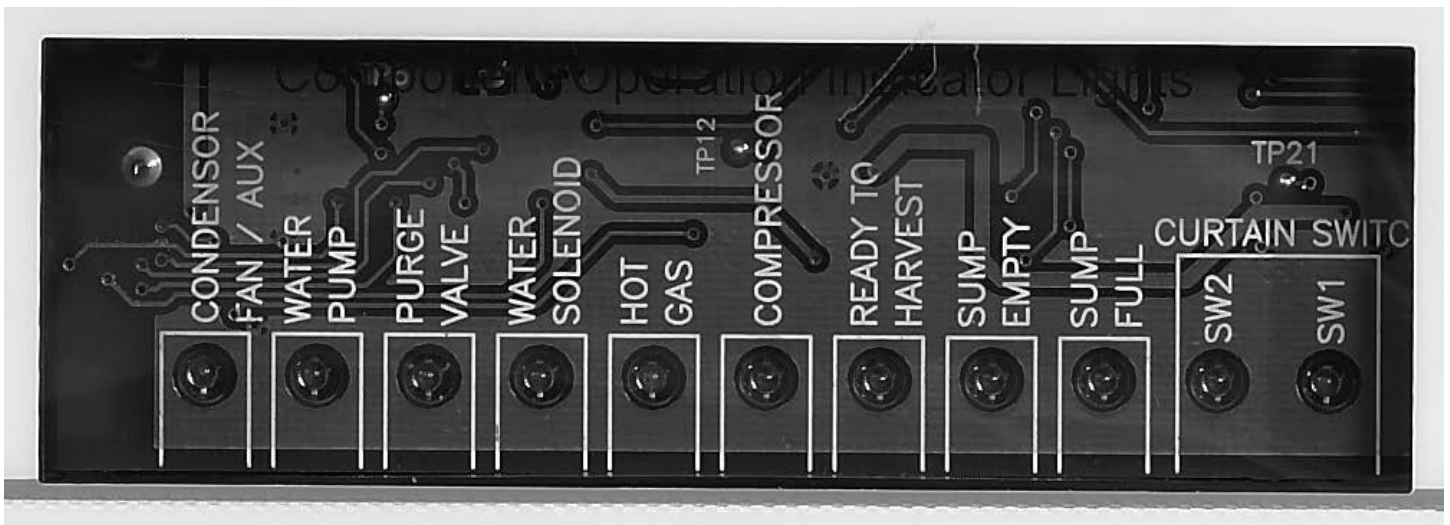

Refrigeration

- Refrigerant: R-404A
- Compressors: Copeland or Tecumseh hermetic by model
- Expansion valves: Non adjustable, internally equalized, one per evaporator.
- Hot gas valves: Pilot operated, line voltage coils. One per plate.
- Condensers: Forced draft air, counterflow water. All air cooled models have left side air inlet.
- 48" wide air cooled models also have front air inlet. All air cooled models exhaust air out the back.
- Air filters: Surface mounted to panels. Filter media removable without removing panels.
- Fan blades: Reduced vibration blades in most air cooled models.
- Remote Systems: Head pressure control valves in condenser. No check valves. Headmaster protected by filters (not filter driers). Controller pumps unit down by closing the liquid line valve and keeping the compressor on for a fixed time period at shut down.
- Fan pressure control. All AC. Controls fan motor operation in the freeze cycle.
- High pressure cut out. WC, RC, AC with Tecumseh compressors.
- Evaporator: Unified cell plate. Nickel plated copper. Three heights: 6", 12" and 18". Small cube = half dice, medium cube = full dice.
- Small cube: 7/8" high x 7/8" deep x 3/8" high
- Medium cube: 7/8" high x 7/8" deep x 7/8" high

Water System

- Batch type. Insulated water reservoir contains full water charge for each ice making cycle.
- Water valve: Solenoid type. Opens to fill reservoir when mid sensor probe no longer makes a circuit to the bottom probe. Closes when reservoir is full and top probe makes circuit to mid probe.
- Pump: Unsealed pedestal type, twist-release mounting
- Water purge valve: Solenoid type. Opens to purge water during harvest cycle.
- Water Level Sensor: Three probe conductivity.
- Distributor: ABS plastic. Evenly distributes water over the evaporator surface. Slides off the evaporator top. Removable cover for ease of cleaning.

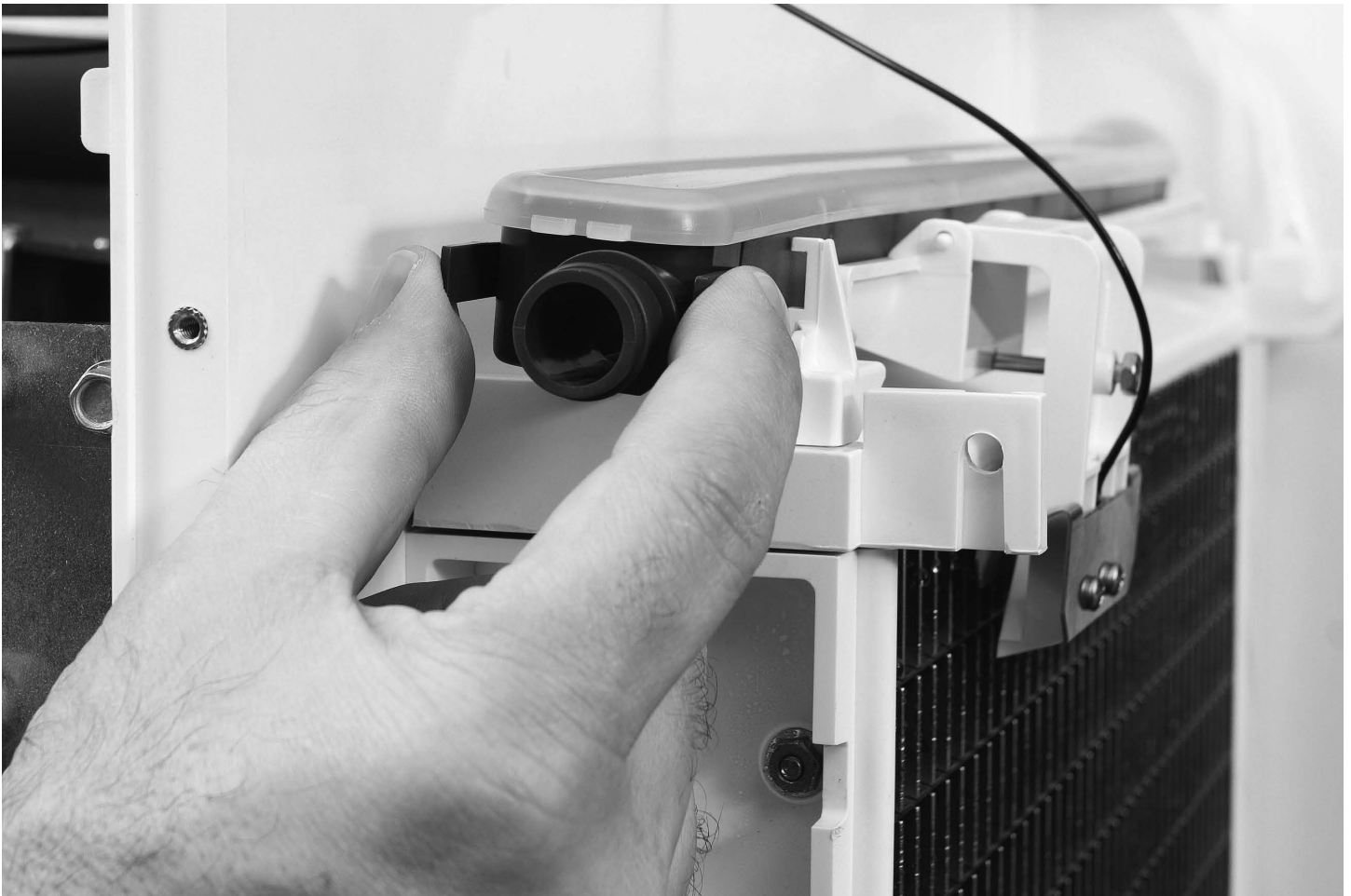

Control Operation

Standard control:

- Electronic controller operating from a 12 AC volt power supply. Will operate within a voltage range between 10 and 15.5.
- User's Indicator lights, four front visible: Power, Status, Water, De-scale/Sanitize.
- Accessible On switch.
- Accessible Off switch.
- Code Display: Displays letters and numbers to indicate cycles and diagnostic codes.
- Manual Harvest switch: Use to trigger harvest at any time.
- Clean switch: Use to initiate and finish the de-scale or sanitizing cycles.
- Component Operation Indicator Lights: Indicate the status of certain components; water level; ready for harvest; curtain switch position.
- Power Light: On when power is being supplied to the controller.
- Status Light: Green when machine is in ice making mode and is operating correctly. Blinks red when a machine malfunction has been detected.
- Water Light: Blinks red when reservoir does not fill with allowed time period.
- De-scale / sanitize: Yellow when the controller has determined it is time to de-scale and sanitize the machine. Use clean process to reset light. Time is determined by power up time and controller's setting. Standard setting is 6 months. See adjustment process

Controller Connections:

- J1 – Ground and Power Supply
- J2 – High voltage power harness to loads
- J3 – Factory use
- J4 – Optional board connector
- J5 - Communications port
- J6 – Thermistor connection
- J7 – Curtain switch
- J8 – Curtain switch
- J9 – Water level sensor
- J10 – Ice thickness sensor
- J11 – Bin thermostat. Use with NO thermostat (closes on temperature fall) & specified harness.
- J13 - Lower switch panel, D series and higher only. If no switch panel, do not connect anything

Control Safeties

Max freeze time – 45 minutes

When exceeded, the controller will attempt another freeze cycle. If the next cycle's freeze time is less than maximum, the control will continue normal ice making. If the next freeze cycle was too long, the control will again attempt another freeze cycle. If the freeze cycle is too long three consecutive cycles, the controller will shut the unit off and it must be manually reset.

Min freeze time – 6 minutes

If the controller switches the machine into harvest within 20 seconds of the minimum freeze time, the controller will harvest for a preset time and does not stop if the curtain switch opens.

If this occurs again in the next three cycles, the machine will shut down and must be manually reset.

Max harvest time – 3.5 minutes

If the harvest cycle has continued for 3.5 minutes without the curtain opening, the controller will shut the machine off for 50 minutes and then restart. If there is another the machine will shut the machine off for another 50 minutes and then restart. If it fails a third consecutive time the controller will shut the machine down and must be manually reset.

- Time between resets – 50 minutes
- Number of automatic resets – 2
- Max water fill time – 5 minutes. Machine will attempt a restart every 20 minutes.
- Max discharge temp – 250 degrees F.
- Time interval between cleanings – 6 months power on time - adjustable in one month increments, can be set at 6, 5, 4 or 3 months of power up time.
- Manual harvest time – 3 minutes
- Pump down interval – remote only. 12 hours. Pump down is 30 seconds of compressor only on time.
- Minimum compressor off time – 4 minutes
- Continuous Run Time Maximum Cycles - 200

Restarts

Power Interruption

The controller will automatically restart the ice machine after adequate voltage has been restored.

- H blinks on code display
- Status indicator light blinks
- Reservoir is drained and refilled
- Default harvest is initiated. The curtain switch does not have to open to terminate harvest, harvest will continue until the default harvest time expires. Default harvest time is 3 minutes. The machine will then return to a normal freeze cycle.

Water Interruption

- The controller will attempt to fill the reservoir every twenty minutes until it is successful..

Control Button Use (from standby)

Set purge level, 1-5 (1 is minimum, 5 is maximum) or Automatic:

- Hold off button in for 3 seconds. Release.
- Press and release the On button to cycle through and select one of the five purge settings or to use the Automatic setting.

Recall diagnostic code:

- Hold off button in for 3 seconds. Release.
- Press and release the Harvest button to cycle through each of the last 10 error codes from most recent to oldest.

Clear diagnostic code:

- Hold Clean and Harvest buttons in for 3 seconds to clear all prior codes. If clean mode begins, push Off.

Reset control:

- Depress and release Off, then depress and release On

Start Test Mode:

- Hold Off button in for 3 seconds. Release.
- Hold Clean button in for 3 seconds. Release.

Lock / Unlock control:

- Hold On button in for 3 seconds, keep holding then press and release Off twice.

Empty reservoir:

- Hold Clean button in for 3 seconds. Release. Pump and purge valve will be ON for 30 seconds. Repeat as needed.

Test Mode:

- Depress Off for 3 seconds, release. Then depress Clean for 3 seconds.
- The sump will fill the first 30 seconds of the test. If the sump is full it will overflow into the bin. At 30 seconds the WIV will shut off and the WP will turn on. You will be able to see and hear the water running over the plates. After 10 seconds the PV and HGV will turn on. Water will be purging from the machine. After 10 more seconds the compressor will start. 5 seconds later the HGV will close. The compressor will run for a total of 20 seconds. After which everything will turn off for 5 seconds. After that time the HGV will open and you'll be able to hear the hissing as the pressure is equalized. 10 seconds later the fan will turn on (if air cooled and fan control jumped). After 10 seconds all will be off and the output test will be complete

Control Button Use - continued

Change De-Scale Notification Interval

Like the others, this feature is accessible only from standby (Status Light Off).

1. Press and hold harvest button for 3 seconds.

Starts the Time to Clean Adjustment State and displays the current time to clean setting.

2. Press the clean button repeatedly to cycle through the 4 possible settings:

Rev 5 and up (10/08 production start)

- 1 year (8760 hours)
- 0 (disabled)
- 4 months (2920 hrs)
- 6 months (4380 hours) (default)

Prior

- 6 months
- 5 months
- 4 months
- 3 months

3. Press Off or leave untouched for 60 seconds to select the displayed interval

Test Mode Sequence Table - Air or Water Cooled

Time (seconds)	On	Off
0	WIV - 30 seconds	WP, HGV, Comp, Fan, PV
30	WP - 10 seconds	WIV, HGV, Comp, Fan, PV
40	WP, PV, HGV - 10 seconds	WIV, Comp, Fan
50	HGV, Comp -	5 seconds WIV, WP, Fan, PV
55	Comp - 15 seconds	WIV, HGV, WP, Fan, PV
70	None -	5 seconds All
75	HGV - 10 seconds	WIV, WP, Comp, Fan, PV
85	Fan - 10 seconds	WIV, HGV, WP, Comp, PV
95	None All -	Test Complete

Test Mode - Remote

Test Time (seconds)	On	Off
0	WIV - 30 seconds	WP, HGV, Comp, BV, PV
30	WP - 10 seconds	WIV, HGV, Comp, BV, PV
40	WP, PV, HGV - 10 seconds	WIV, Comp, BV
50	HGV, Comp - 5 seconds	WIV, WP, BV, PV
55	Comp - 15 seconds	WIV, HGV, BV, WP, PV
70	None - 5 seconds	All
75	HGV - 5 seconds	WIV, WP, Comp, BV, PV
80	BV - 5 seconds	WIV, HGV, WP, Comp, PV
85	None	All - Test Complete

Compressor Electrical Chart

Resistance reading tolerance is +- 10%

Ice Machine	Series	Voltage/Hz/Phase	Compressor	Start Winding Ohms	Run Winding Ohms
C0322 or C0330-1	A B D	115/60/1	AKA9438ZXA	4.22	.59
C0330-6	A or B	230/50	AKA9438ZXC	7.11	2.69
C0330-32	A or B	208-230/60/1	AKA9468ZXD	10.43	1.77
C0522 or C0530-1	A or B	115/60/1	AKA9451ZXA	5.95	.69
C0530-6	A or B	230/50	AKA9451ZXC	7.11	2.69
C0530-32	A or B	208-230/60/1	AKA9451ZXD	10.43	1.77
C0530 -1	C or D	115/60/1	RST45C1E-CAA		
C0530 - 6	C or D	230/50/1	RST45C1E-CAB		
C0530 - 32	C or D	208-230/60/1	RST45C1E-CAV		
C0722 or C0630-32	A B D	208-230/60/1	AJA7490ZXD	2.74	1.52
C0630-6	A B D	230/50	AJA7490ZXC	2.23	2.02
C0830-32	A B D	208-230/60/1	CS10K6EPFV	3.10	1.16
C0830-6	A B D	230/50	CS10K6EPFJ	3.79	1.39
C0830-3	A B D	208-230/60/3	CS10K6ETF5	-	1.77
C1030-32	A B D	208-230/60/1	CS12K6EPFV	3.10	1.16
C1030-6	A B D	230/50	CS12K6EPFJ	3.79	1.39
C1030-3	A B D	208-230/60/3	CS12K6ETF5	-	1.77
C1448-32	A B D	208-230/60/1	CS14K6EPFV	2.66	1.08
C1448-6	A B D	230/50	CS14K6EPFJ	2.64	1.4
C1448-3	A B D	208-230/60/3	CS14K6ETF5	-	-
C1848-32	A B D	208-230/60/1	CS20K6EPFV	2.37	.65
C1848-6	A B D	230/50	CS20K6EPFZ		
C1848-3	A B D	208-230/60/3	CS20K6ETF5	-	-
C2148-32	A B D	WC 208-230/60/1	CS24K6EPFV	2.35	.53
C2148-6 WC	A B D	230/50	CS24K6EPFZ		
C2148-3 WC	A B D	208-230/60/3	CS24K6ETF5	-	-
C2148-32 R	A B D	208-230/60/1	CS27K6EPFV	2.35	.53
C2148-6 R	A B D	230/50	CS27K6EPFZ		
C2148-32 R	A B D	208-230/60/3	CS27K6ETF5		

Refrigerant Charges and Pressure Switches

Model	R-404A in ounces
C0322A	14
C0322W	11
C0330A	14
C0330W	11
C0522A	17
C0522W	14
C0522R	160
C0530A (A or B series)	22
C0530A C series	21
C0530W (A thru C series)	11
C0530R (A thru C series)	160
C0630A	36
C0630W	14
C0630R	160
C0722A	17
C0830A	46
C0830W	34
C0830R	208
C1030A	48
C1030W	38
C1030R	208
C1448A	62
C1448W	56
C1448R	256
C1848A	62
C1848W	63
C1848R	320
C2148W	69
C2148R	320

Pressure Switches Cut In, Cut Out

	Cut In (PSIG)	Cut Out (PSIG)
Fan Pressure Control, 22" and 30"	240	190
Fan Pressure Control, 48"	280	220
High Pressure Cut Out AC	390	500
High Pressure Cut Out WC	300	400
High Pressure Cut Out, Remote	350	450

Compressor Amp Draws

- amps peak and then decline during each cycle

	Series	Voltage	Brand	Base Model	Freeze	Harvest
C0322	A B D	115	Tecumseh	AKA9438	7.3 - 4.8	6.2
	A B D	230	Tecumseh			
C0522	A B D	115	Tecumseh	AKA9451	7.9 - 6.5	7.2
	A B D	230	Tecumseh		6 - 4.5	6
C0330	A B	115	Tecumseh	AKA9438	6.2 - 4.8	5.7
	A B	230	Tecumseh			
C0330 C	C D	115	Copeland	RST45	7 - 5.3	6.4 - 7
	C D	230	Copeland			
C0530 A or B	A B	115	Tecumseh	AKA9451	8 - 6.5	9.3
	A B	230	Tecumseh			
C0530 C	C D	115	Copeland	RST45	6.9 - 5.5	6.6 - 7.0
	C D	230	Copeland	RST45	3 - 2.2	2.5
C0722 or C0630	A B D	230	Tecumseh	AJA7490	5.8 - 5.0	6.8
C0830	A B D	single phase	Copeland	CS10	6.4 - 5.3	6.6
	A B D	three phase	Copeland		4.5 - 3.5	5
C1030	A B D	single phase	Copeland	CS12	7.3 - 4.8	6.2
	A B D	three phase	Copeland		4.4 - 3.2	5.5
C1448	A B D	single phase	Copeland	CS14	12.5 - 7.6	9.2
	A B D	three phase	Copeland		7.2 - 4.5	5.5 - 5.7
C1848	A B D	single phase	Copeland	CS20	16 - 10	15
	A B D	three phase	Copeland		14 - 8	10
C2148 W	A B	single phase	Copeland	CS24	18 - 12	18
	A B	three phase	Copeland		10.5 - 7.2	14
C2148R	A B D	single phase	Copeland	CS27	20 - 14	19.6 - 16
	A B D	three phase	Copeland		13.5 - 8	13 - 12

Heat Load & Condenser Water GPM

Air Cooled - Average heat load for air conditioning unit sizing

Model	BTUH
C0322	5200
C0522	7900
C0330	5200
C0530	7900
C0630	12700
C0722	12700
C0830	13700
C1030	16200
C1448	20000
C1848	27400

Water Cooled Water Use - condenser only,

Model	GPM, 45°F. water inlet temp	GPM, 70°F. water nlet temp
C0322	.2	.3
C0522	.3	.7
C0330	.1	.3
C0530	.3	.5
C0630	.4	.7
C0803	.4	.8
C1030	.4	1.0
C1448	.6	1.1
C1848	1.0	1.8
C2148	1.0	2.0

Thermistor Values

Deg. F	Ohms	Deg. F	Ohms	Deg. F	Ohms	Deg. F	Ohms	Deg. F	Ohms
0	85325	51	19381	102	5569	153	1927	204	774
1	82661	52	18873	103	5446	154	1890	205	761
2	80090	53	18381	104	5325	155	1855	206	749
3	77607	54	17903	105	5208	156	1819	207	737
4	75210	55	17439	106	5093	157	1785	208	724
5	72896	56	16988	107	4981	158	1752	209	713
6	70660	57	16551	108	4872	159	1719	210	701
7	68501	58	16126	109	4766	160	1687	211	690
8	66415	59	15714	110	4663	161	1655	212	679
9	64400	60	15313	111	4562	162	1624	213	668
10	62453	61	14924	112	4463	163	1594	214	657
11	60571	62	14546	113	4367	164	1565	215	646
12	58752	63	14179	114	4273	165	1536	216	636
13	56995	64	13823	115	4182	166	1508	217	626
14	55296	65	13476	116	4093	167	1480	218	616
15	53653	66	13139	117	4006	168	1453	219	606
16	52065	67	12812	118	3921	169	1427	220	597
17	50529	68	12494	119	3838	170	1401	221	587
18	49043	69	12185	120	3757	171	1375	222	578
19	47607	70	11884	121	3678	172	1350	223	569
20	46217	71	11592	122	3601	173	1326	224	560
21	44872	72	11308	123	3526	174	1302	225	551
22	43571	73	11031	124	3452	175	1279	226	543
23	42313	74	10763	125	3381	176	1256	227	534
24	41094	75	10502	126	3311	177	1234	228	526
25	39915	76	10247	127	3243	178	1212	229	518
26	38774	77	10000	128	3176	179	1190	230	510
27	37669	78	9760	129	3111	180	1169	231	502
28	36600	79	9526	130	3047	181	1149	232	495
29	35564	80	9299	131	2985	182	1129	233	487
30	34561	81	9077	132	2924	183	1109	234	480
31	33590	82	8862	133	2865	184	1090	235	472
32	32649	83	8652	134	2807	185	1071	236	465
33	31738	84	8448	135	2751	186	1052	237	458
34	30855	85	8250	136	2696	187	1034	238	451
35	30000	86	8056	137	2642	188	1016	239	444
36	29171	87	7868	138	2589	189	998	240	438
37	28368	88	7685	139	2537	190	981	241	431
38	27589	89	7507	140	2487	191	965	242	425
39	26835	90	7333	141	2438	192	948	243	419
40	26104	91	7164	142	2390	193	932	244	412
41	25395	92	6999	143	2343	194	916	245	406
42	24707	93	6839	144	2297	195	901	246	400
43	24041	94	6683	145	2252	196	885	247	394
44	23394	95	6530	146	2208	197	871	248	389
45	22767	96	6382	147	2165	198	856	249	383
46	22159	97	6238	148	2123	199	842	250	377
47	21569	98	6097	149	2082	200	828		
48	20997	99	5960	150	2042	201	814		
49	20442	100	5826	151	2003	202	800		
50	19903	101	5696	152	1965	203	787		

Cleaning - A, B or C Series

All models have an indicator light that switches on to inform the user that the cleaning interval has been reached. It does not stop the machine from making ice.

All models have a Clean mode. In the A, B or C series machines, it is a **two-step, user timed system**.

After readying the machine for cleaning, the first push of the Clean button drains the reservoir and refills it. The cleaning process is designed to use straight nickel safe ice machine scale remover, added between draining and refilling. After the scale remover has been added, the person cleaning the machine is in control of how long to circulate the scale remover.

It is important that the Sump Empty light switch on during this part of cleaning, if it does not the inlet water valve will not add water and the scale remover cannot circulate. If this occurs, push off, un-snap the Water Level Sensor and lift slightly, then push Clean again.

A second push of the Clean button starts the flush out process. This drains and refills the reservoir until the person cleaning the machine pushes the Off button. This process should last at least 20 minutes to fully flush out the scale remover and loose scale.

It is the second push of the Clean button that clears the Cleaning Reminder Light

After the scale remover has been drained out, the water distributor must be inspected for loose scale and cleaned of any. Removal of the sump cover, pump bracket and curtain is next to be sure those parts have been cleaned.

Cycle power to the controller as a final step before restarting ice making.



Cleaning - Prodigy Plus D Series

All models have an indicator light that switches on to inform the user that the cleaning interval has been reached. It does not stop the machine from making ice.

All models have a Clean mode. In the D series machines, it is a **single step, automatic system**.

A single push of the Clean button puts the machine into a Manual Harvest to release any ice and warm up the system, then it drains the reservoir and refills it. The cleaning process is designed to use straight nickel safe ice machine scale remover, added between draining and refilling. The controller will indicate the proper time to add the scale remover by blinking A d 1.

The rest is automatic, the controller will circulate and then flush out the scale remover. No manual timing is needed.

After the scale remover has been drained out, the water distributor must be inspected for loose scale and cleaned of any. Removal of the sump cover, pump bracket and curtain is next to be sure those parts have been cleaned.

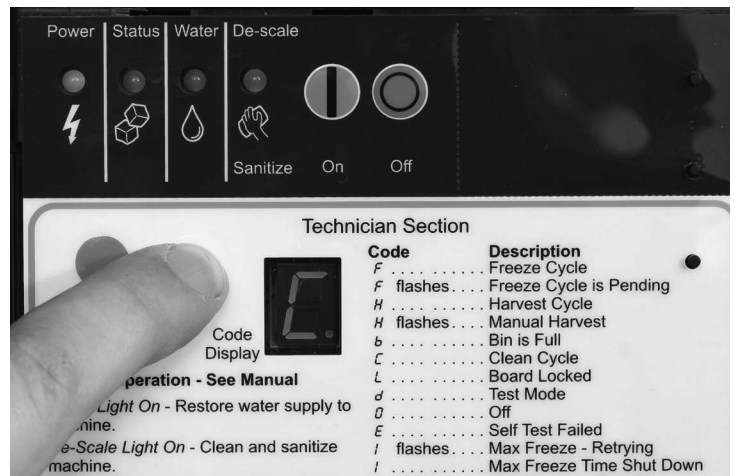

Critical Maintenance - Water Level Sensor



1. Remove Water Level Sensor

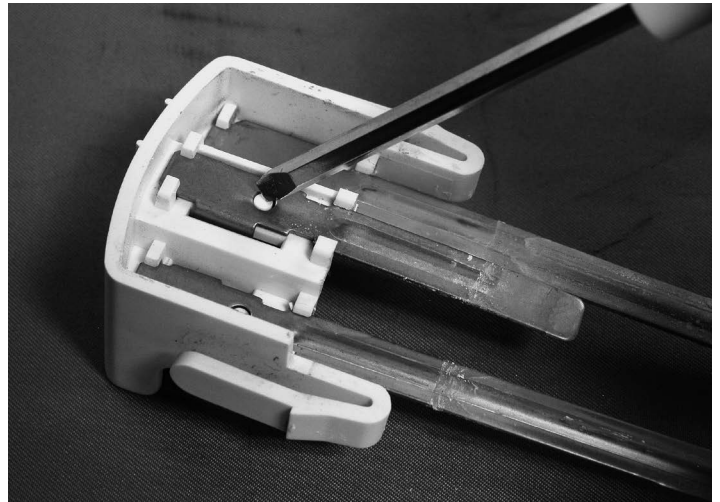

2. Release probes by pushing pins in.

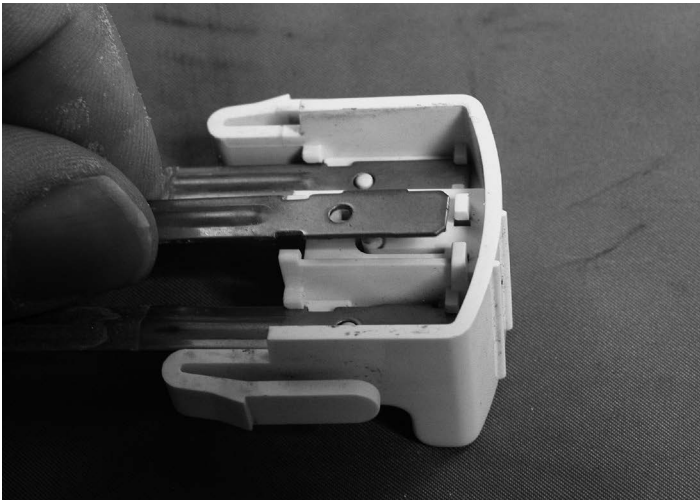

3. Pull down, then lift up to remove probe.

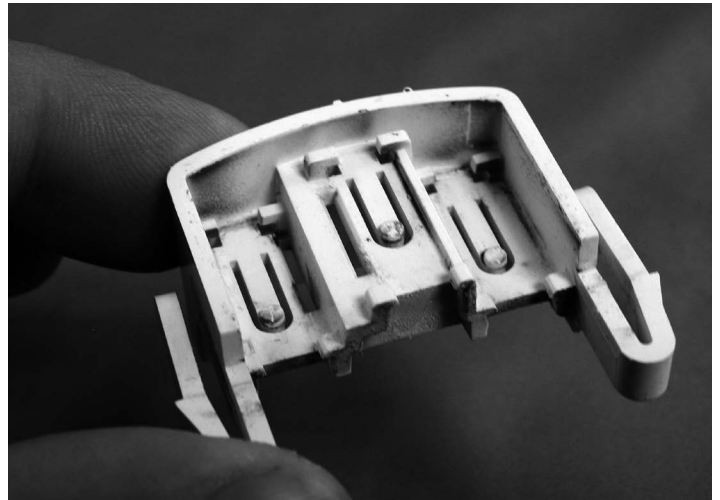

4. Clean all dirty and scale from the housing.

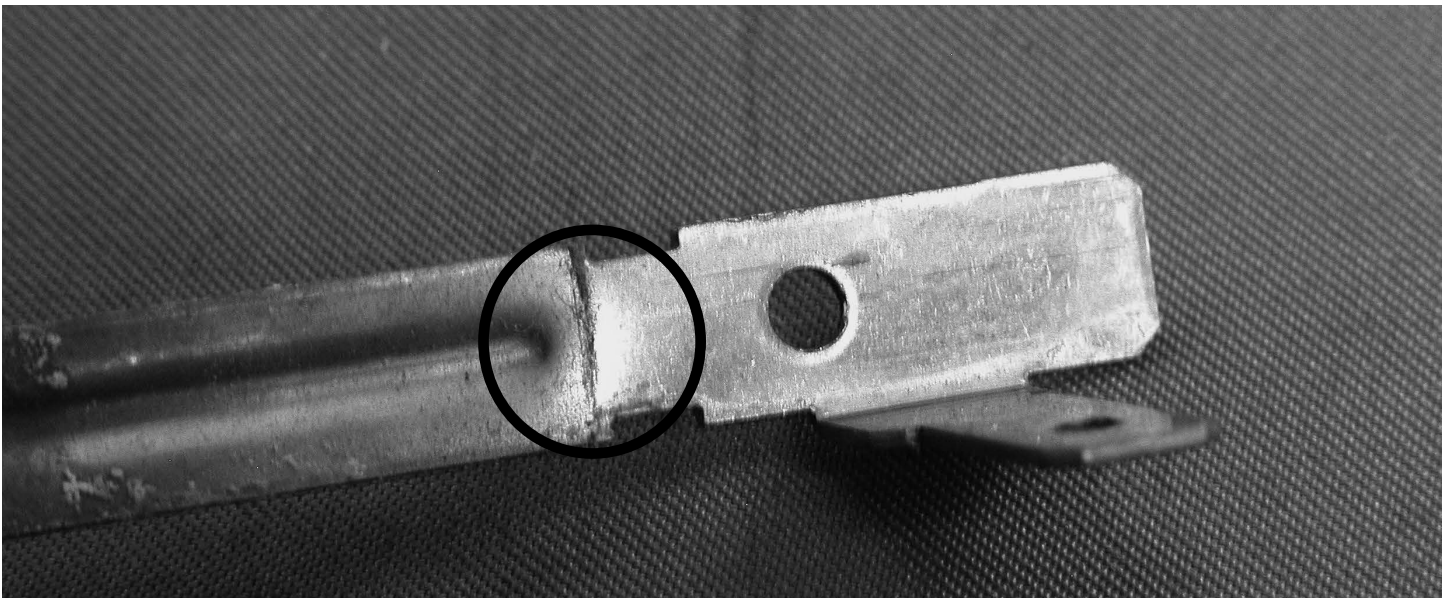

5. Clean entire probe, be sure circled area is clean.

Critical Maintenance - Ice Thickness Sensor

The freeze cycle on a Prodigy cuber is controlled by an ice thickness sensor positioned in front of the ice making surface. It is triggered by water contact. Water contacts the sensor when the ice is at the proper size.

During use the Ice Thickness Sensor will become coated with mineral scale from the water, which if left untreated can cause changes in bridge thickness.

To correct, the Ice Thickness Sensor must have the mineral scale removed.

1. Remove the ice thickness sensor from the water distributor bracket.
2. Separate the metal sensor from the plastic insulator-bracket.
3. Wipe the sensor with diluted ice machine scale remover,
4. Scrub the white or dark gray plastic insulator-bracket with diluted ice machine scale remover and remove all traces of mineral build up
5. Wipe the wire to the bulkhead with diluted ice machine scale remover.
6. Wash all ice thickness sensor parts off with clean water.
7. Blow air thru metal sensor and insulator-bracket to dry them.
8. Reassemble and remount to water distributor bracket.

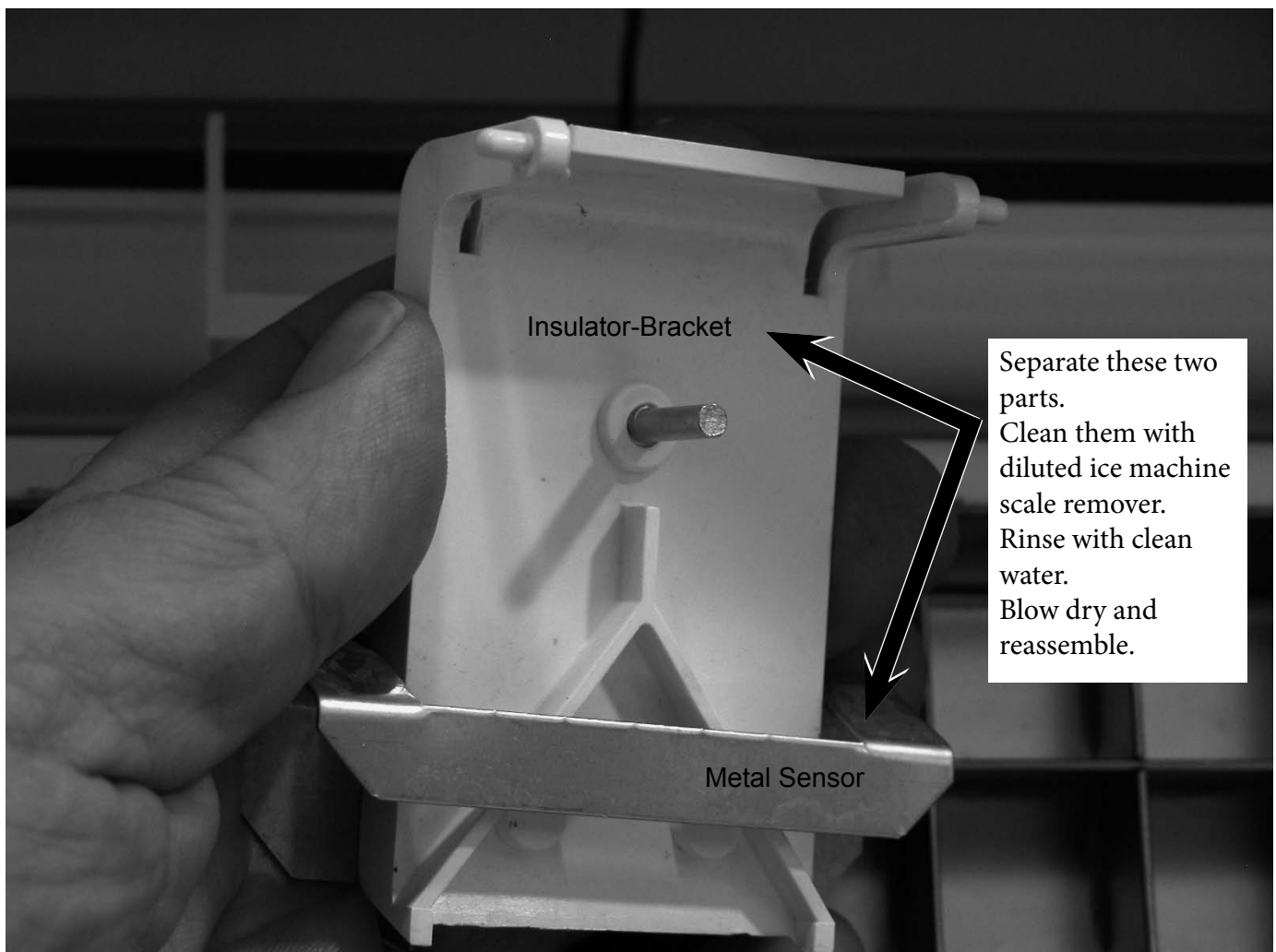

Critical Maintenance - Spillway

The freeze cycle on a Prodigy cuber is controlled by an ice thickness sensor positioned in front of the ice making surface. It is triggered by water contact. Normally water only contacts the sensor when the ice is at the proper size. However, irregular water flow can cause premature contact resulting in a short freeze cycle, small bridge, long harvest and even a shut down on short freeze (code 8).

The primary procedure for correcting poor water flow is to scrub the spillway surface.

1. Shut machine off.
2. Remove right side panel liner and panel.
3. Disconnect ice thickness sensor from its bracket and move out of the way.
4. Scrub 4 to 6 strokes across the normal flow of water. A clean nylon scrubbing pad is the recommended tool.
5. Reassemble all components and retest operation.



Other short freeze causes include:

- Mis-adjustment of ice thickness sensor.
- Broken, bent, or dismantled ice thickness sensor.
- Sagging water distributor mounting bracket. See Service Bulletin PS-9-2012.

Diagnostics – Air Cooled

No ice

Problem	Likely Cause	Probable Solution
No power to unit	Power disconnected Check breaker or fuse. Reset or replace, restart and check	
No power to controller	Transformer open	Replace transformer
Shut down on maximum water fill time	Water shut off	Restore water supply
Shut down on maximum freeze time	Water leak	Check purge valve, curtain, sump, pump hose
	Air filters clogged	Clean air filters
	Dirty condenser	Clean condenser
	Restricted location, intake air too hot	Have machine moved
	Ice thickness sensor dirty or disconnected	Check ice thickness sensor probe
	Water distributor dirty	Remove and clean water distributor
	Inlet water valve leaks through during freeze	Check inlet water valve
	Connected to hot water	Check for bleed thru from / missing check valve in building water supply
	Incomplete harvest	Check harvest system
	High pressure cut out opened	Check fan motor pressure control, check fan motor, check controller using test mode
	Fan motor pressure control open	Check fan pressure control
	Fan motor not turning	Check fan motor, check fan blade, check controller using test mode
	Water pump not pumping	Check pump motor, check controller using test mode
	Pump hose disconnected	Check hose
	Compressor not operating	Check compressor contactor, check controller using test mode
		Check compressor start components, check PTCR resistance and temperature
		Check compressor voltage
		Check compressor windings
	Low refrigerant charge	Add some refrigerant and restart unit. If cycle time improves, look for leak.
	Hot gas valve leaks through during freeze	Check hot gas valve for hot outlet during freeze
Thermostatic expansion valve bulb loose	Check bulb	
Thermostatic expansion valve producing very low or very high superheat	Check evaporator superheat, change TXV if incorrect	
Compressor inefficient	Check compressor amp draw, if low and all else is correct, change compressor	

Diagnostics - Air Cooled

Problem	Likely Cause	Probable Solution
Shut down on maximum harvest time	Ice bridge thickness too small, not enough ice to open curtain	Check and adjust if needed
	Ice bridge thickness too large, ice frozen to evaporator frame	Check and adjust if needed
	Purge valve does not open, water melts ice bridge, not enough ice to open curtain	Check purge valve
	Incomplete ice formation	Check water distributor for partially plugged holes
	Curtain out of position	Check curtain for swing restriction
	Curtain switch does not open when curtain does	Check switch with ohmmeter
	Machine in very cold ambient	Move machine to a warmer location
	Hot gas valve does not open	Check hot gas valve, check controller using test mode
	Harvest assist probe out of position – ejector pin not retracted	Check harvest assist mechanism – spring should retract pin
	Damaged evaporator	Check evaporator surface
	Fan motor stays on during harvest	Check controller using test mode
Shut down on minimum freeze time	Grounded ice thickness sensor	Check sensor for dirt and position. Clean and check gap to evaporator surface
	Restricted water distributor	Clean water distributor
	Dirty spillway surface	Scrub spillway
	Bridge thickness too thin	Adjust to correct thickness

Low Ice Making Capacity - Air Cooled

Problem	Likely Cause	Probable Solution
Long freeze cycle	Dirty air filters	Clean filters
	Dirty condenser	Clean condenser
	Hot ambient	Reduce room air temperature
	Water leak	Check purge valve, check curtain
	Water inlet valve leaks through	Check inlet valve
	Low on refrigerant	Add refrigerant, if cycle time drops, check for leak
	Incorrect superheat	Check evaporator superheat, if significantly low or high, replace TXV
	Fan(s) cycle on and off	Check pressures fans cycle at. Replace fan pressure switch if too low
Long Harvest Cycle	Dirty evaporator	De-scale water system
	No harvest assist	Check harvest assist solenoid
	Bridge thickness too big	Check and adjust bridge thickness
	Machine in very cool ambient	Increase room temperature
False bin full signal	Ice jammed in between curtain and sump	Clear ice away
	Curtain does not close correctly	Check curtain for proper swing

Makes Excessive Noise - Air cooled

Problem	Likely Cause	Probable Solution
Fan blade vibrates	Blade is bent	Replace fan blade
	Fan motor mount is broken	Replace motor mount
Compressor vibrates	Mounting bolts loose	Tighten bolts
Water pump vibrates	Pump bearings worn	Replace pump
Panels vibrate	Mounting screws loose	Tighten screws

Diagnostics – Water Cooled

No ice

Problem	Likely Cause	Probable Solution
No power to unit	Power disconnected Check breaker or fuse. Reset or replace, restart and check	
No power to controller	Transformer open	Replace transformer
Shut down on maximum water fill time	Water shut off	Restore water supply
Shut down on maximum freeze time	Water leak	Check purge valve, curtain, sump, pump hose
	Ice thickness sensor dirty or disconnected	Check ice thickness sensor probe
	Water distributor dirty	Remove and clean water distributor
	Inlet water valve leaks through during freeze	Check inlet water valve
	Connected to hot water	Check for bleed thru from / missing check valve in building water supply
	Incomplete harvest	Check harvest system
	High pressure cut out opened	Water supply cut off, restore water supply to condenser
	Fan motor pressure control open	Check fan pressure control
	Fan motor not turning	Check fan motor, check fan blade, check controller using test mode
	Water pump not pumping	Check pump motor, check controller using test mode
	Pump hose disconnected	Check hose
	Compressor not operating	Check compressor contactor, check controller using test mode
		Check compressor start components, check PTCR resistance and temperature
		Check compressor voltage
		Check compressor windings
	Low refrigerant charge	Add some refrigerant and restart unit. If cycle time improves, look for leak.
	Hot gas valve leaks through during freeze	Check hot gas valve for hot outlet during freeze
Thermostatic expansion valve bulb loose	Check bulb	
Thermostatic expansion valve producing very low or very high superheat	Check evaporator superheat, change TXV if incorrect	
Compressor inefficient	Check compressor amp draw, if low and all else is correct, change compressor	

Diagnostics - Water Cooled

Problem	Likely Cause	Probable Solution
Shut down on maximum harvest time	Ice bridge thickness too small, not enough ice to open curtain	Check and adjust if needed
	Ice bridge thickness too large, ice frozen to evaporator frame	Check and adjust if needed
	Purge valve does not open, water melts ice bridge, not enough ice to open curtain	Check purge valve
	Incomplete ice formation	Check water distributor for partially plugged holes
	Curtain out of position	Check curtain for swing restriction
	Curtain switch does not open when curtain does	Check switch with ohmmeter
	Machine in very cold ambient	Move machine to a warmer location
	Hot gas valve does not open	Check hot gas valve, check controller using test mode
	Harvest assist probe out of position – ejector pin not retracted	Check harvest assist mechanism – spring should retract pin
	Damaged evaporator	Check evaporator surface
Shut down on minimum freeze time	Grounded ice thickness sensor	Check sensor for dirt and position. Clean and check gap to evaporator surface
	Restricted water distributor	Clean water distributor
	Dirty spillway surface	Scrub spillway
	Bridge thickness too thin	Adjust to correct thickness

Low Ice Making Capacity - Water Cooled

Problem	Likely Cause	Probable Solution
Long freeze cycle	Dirty air filters	Clean filters
	Dirty condenser	Clean condenser
	Hot ambient	Reduce room air temperature
	Water leak	Check purge valve, check curtain
	Water inlet valve leaks through	Check inlet valve
	Low on refrigerant	Add refrigerant, if cycle time drops, check for leak
	Incorrect superheat	Check evaporator superheat, if significantly low or high, replace TXV
	Fan(s) cycle on and off	Check pressures fans cycle at. Replace fan pressure switch if too low
Long Harvest Cycle	Dirty evaporator	De-scale water system
	No harvest assist	Check harvest assist solenoid
	Bridge thickness too big	Check and adjust bridge thickness
	Machine in very cool ambient	Increase room temperature
False bin full signal	Ice jammed in between curtain and sump	Clear ice away
	Curtain does not close correctly	Check curtain for proper swing

Makes Excessive Noise - Water cooled

Problem	Likely Cause	Probable Solution
Compressor vibrates	Mounting bolts loose	Tighten bolts
Water pump vibrates	Pump bearings worn	Replace pump
Panels vibrate	Mounting screws loose	Tighten screws

Diagnostics – Remote Air Cooled

No ice

Problem	Likely Cause	Probable Solution	
No power to unit	Power disconnected Check breaker or fuse. Reset or replace, restart and check		
No power to controller	Transformer open	Replace transformer	
Shut down on maximum water fill time	Water shut off	Restore water supply	
Shut down on maximum freeze time	Water leak	Check purge valve, curtain, sump, pump hose	
	Dirty condenser	Clean condenser	
	Restricted location, intake air too hot	Have condenser moved	
	Ice thickness sensor dirty or disconnected	Check ice thickness sensor probe	
	Water distributor dirty	Remove and clean water distributor	
	Inlet water valve leaks through during freeze	Check inlet water valve	
	Connected to hot water	Check for bleed thru from / missing check valve in building water supply	
	Incomplete harvest	Check harvest system	
	High pressure cut out opened	Check fan motor pressure control, check fan motor, check controller using test mode	
	Fan motor not turning	Check fan motor, check fan blade	
	Water pump not pumping	Check pump motor, check controller using test mode	
	Pump hose disconnected	Check hose	
	Compressor not operating		Check compressor contactor, check controller using test mode
			Check compressor start components, check PTCR resistance and temperature
			Check compressor voltage
			Check compressor windings
	Low refrigerant charge		Add some refrigerant and restart unit. If cycle time improves, look for leak.
	Hot gas valve leaks through during freeze		Check hot gas valve for hot outlet during freeze
	Thermostatic expansion valve bulb loose		Check bulb
	Thermostatic expansion valve producing very low or very high superheat		Check evaporator superheat, change TXV if incorrect
Liquid line valve does not open		Check coil of valve, check controller using test mode	
Compressor inefficient		Check compressor amp draw, if low and all else is correct, change compressor	
Debris in refrigeration system		Recover charge. Open quick connects, check for loose or missing foil. Open liquid line and hot gas valves. Check for debris. Replace drier, evacuate and weigh in nameplate charge.	

Diagnostics - Remote Air Cooled

Problem	Likely Cause	Probable Solution
Shut down on maximum harvest time	Ice bridge thickness too small, not enough ice to open curtain	Check and adjust if needed
	Ice bridge thickness too large, ice frozen to evaporator frame	Check and adjust if needed
	Purge valve does not open, water melts ice bridge, not enough ice to open curtain	Check purge valve
	Incomplete ice formation	Check water distributor for partially plugged holes
	Curtain out of position	Check curtain for swing restriction
	Curtain switch does not open when curtain does	Check switch with ohmmeter
	Hot gas valve does not open	Check hot gas valve, check controller using test mode
	Harvest assist probe out of position – ejector pin not retracted	Check harvest assist mechanism – spring should retract pin
	Damaged evaporator	Check evaporator surface
Shut down on minimum freeze time	Grounded ice thickness sensor	Check sensor for dirt and position. Clean and check gap to evaporator surface
	Restricted water distributor	Clean water distributor
	Dirty spillway surface	Scrub spillway
	Bridge thickness too thin	Adjust to correct thickness

Low Ice Making Capacity - Remote Air Cooled

Problem	Likely Cause	Probable Solution
	Dirty condenser	Clean condenser
	Hot ambient	Check condenser inlet temp
	Water leak	Check purge valve, check curtain
	Water inlet valve leaks through	Check inlet valve
	Low on refrigerant	Add refrigerant, if cycle time drops, check for leak
	Incorrect superheat	Check evaporator superheat, if significantly low or high, replace TXV
Long Harvest Cycle	Dirty evaporator	De-scale water system
	No harvest assist	Check harvest assist solenoid
	Bridge thickness too big	Check and adjust bridge thickness
	Machine in very cool ambient	Increase room temperature
False bin full signal	Ice jammed in between curtain and sump	Clear ice away
	Curtain does not close correctly	Check curtain for proper swing

Makes Excessive Noise - Air cooled

Problem	Likely Cause	Probable Solution
Fan blade vibrates	Blade is bent	Replace fan blade
	Fan motor mount is broken	Replace motor mount
Compressor vibrates	Mounting bolts loose	Tighten bolts
Water pump vibrates	Pump bearings worn	Replace pump
Panels vibrate	Mounting screws loose	Tighten screws

Test Procedures - Sensors

All electrical components in this ice machine can be diagnosed with a volt-ohmmeter.

Curtain Switch:

1. Test using the controller's indicator lights. Observe SW1 and SW2. Open and close the curtain in question. When the curtain is opened, the SW light will be ON. When the curtain gets to within a half inch of closing (at the switch) the SW light will go OUT.
2. Test with an ohmmeter. Disconnect electrical power. Open the control box cover. Unplug the curtain switch lead from the controller. Connect an ohmmeter to the leads of the switch. Open and close the curtain. When the curtain is closed, the switch is closed and there will be continuity. When the curtain is open, the switch is open and the circuit will be open.
3. Test the controller's curtain switch circuit by jumping the connectors on J1 or J2 together. Reconnect electrical power. When jumped, the matching SW light will go out. When unplugged or open, the SW light will be ON.

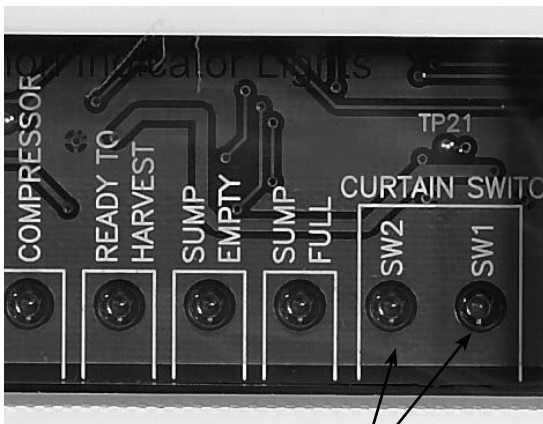

Curtain Switch
Indicator Lights

Light is ON when
curtain is OPEN

Single curtain models
have one indicator
light ON all the time.



Ice Thickness Sensor

1. Test using the controller's indicator light. Observe the Ready To Harvest light. Shut the machine off. Use a wire to connect the metal part of the Ice Thickness sensor to the evaporator or simply remove the Ice Thickness Sensor and touch its metal surface to the metal control box wall. The Ready for Harvest light should go ON.
2. Test with an Ohmmeter. Disconnect electrical power. Open the control box cover. Unplug the ice thickness sensor lead from the controller. Connect an ohmmeter lead to the ice thickness sensor lead, touch the other ohmmeter lead to the ice machine chassis. There must be an open circuit. If there is continuity, the sensor must be replaced. If there is no continuity, touch the ohmmeter lead to the metal part of the ice thickness sensor. There should be continuity. If open, check the ice thickness sensor for scale build up. Clean and recheck. If still open, replace the ice thickness sensor.
3. Test the controller's ice thickness sensor circuit by connecting a wire from J10 to ground. Reconnect electrical power. The Ready for Harvest light should go ON.

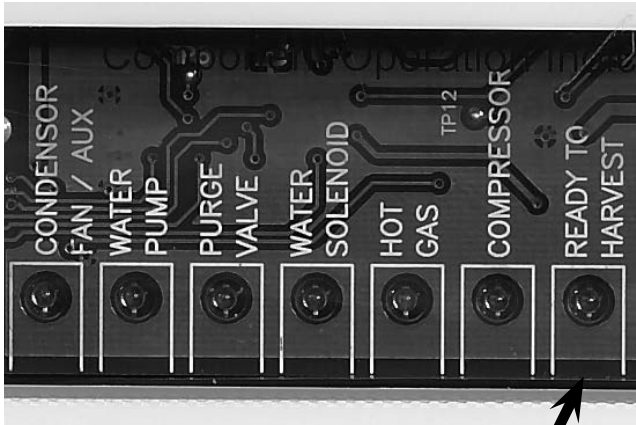

Ready To Harvest light is ON when water contacts ice thickness sensor.



Ice Thickness Sensor

Water Level Sensor

1. Test using the controller's indicator lights (sump empty and sump full). Unit must be powered up and there must be water in the sump. Add some manually if needed. Locate water level sensor. Release from sump cover and slowly lift up until the mid-length probe is out of the water. The sump empty light should come on, and if the unit is on the inlet water solenoid valve will open to fill the reservoir. Return the water level sensor to its normal position. If the unit is on and calling for ice the water will fill until the top probe is in contact with it, at that time the sump full light will switch ON.

2. Test with an ohmmeter. Disconnect electrical power. Open the control box cover. Unplug the connector at J9. Locate water level sensor and remove it from the sump cover. Test 1: Place one lead of the ohmmeter on the longest probe and the other on the controller end of the red wire, there should be continuity. Test 2: Place one lead on the controller end of the white wire and the other on the mid-length probe, there should be continuity. Test 3: Place one lead on the controller end of the black wire and the other on the shortest probe, there should be continuity.

If not, clean the probes and recheck.

3. Test the controller's water level sensor circuit. Reconnect electrical power. Unplug harness from water level sensor, the sump empty light should be ON. Jump harness wires white and black. The sump full light should be ON. Jump harness wires white and red, the sump full and sump empty lights will be OFF. Check harness wire by wire for continuity if there is no reaction from the controller during this test.

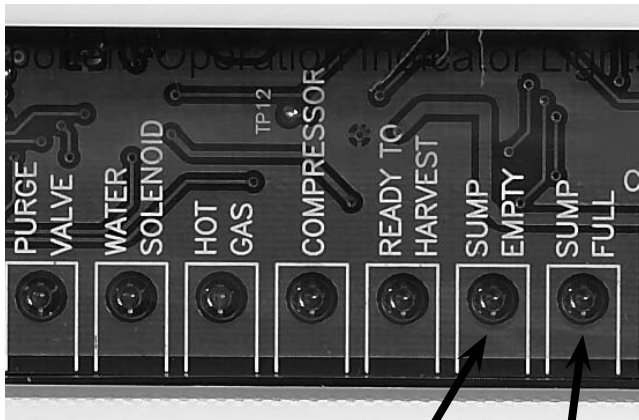

Sump Empty Light

Sump Full Light



Temperature Sensors

1. Check controller. If the sensor calibration is completely out of range, the code display will read either 5 or 7.
2. Check with an ohmmeter.
 - Open control box cover, unplug sensor from J6. Water temperature probe:
 - Measure the temperature of the water.
 - Push and release the clean button.
 - Wait one minute.
 - Measure the resistance of the water probe (two leads next to the open socket) and compare to the resistance in the chart for that temperature. Any reading within 1000 ohms is acceptable.

Discharge sensor:

- Measure the temperature of the discharge line as close to the sensor as possible.
 - Measure the resistance of the discharge temperature sensor (two leads farthest away from the open socket on the harness connector) and compare to the resistance in the chart for that temperature. Any reading within 1000 ohms is acceptable.
3. Alternate procedure: Remove both water and discharge sensors from their places on the ice machine. Put both into a container of ice water. Put a thermometer in the water. When the thermometer is at 32 degrees F., check the resistance of each sensor. The resistance should be within 1000 ohms of 32649.

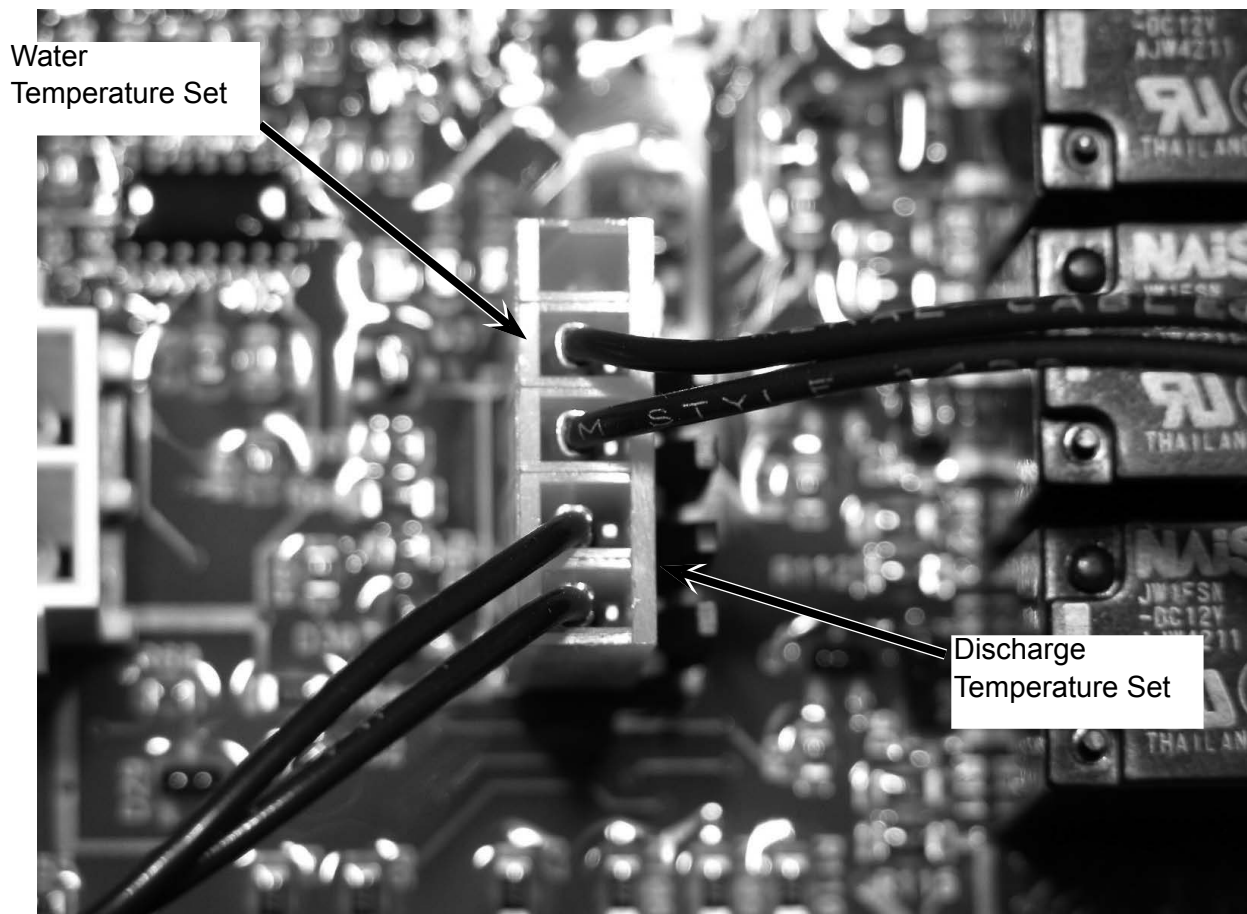

Test Procedures - Compressor

Failure to start.

Single phase models. All have resistance start, capacitor run type motors. Check voltage to compressor at the contactor. Compare the idle voltage (compressor off) to the active voltage (compressor starting). The supply voltage must not be less than the lowest rated voltage for the ice machine. If the voltage is correct, proceed to the next step.

Check starting components. Most models use a PTCR to cut power to the start winding after the compressor has started. Check the PTCR for resistance. The resistance check must be when the PTCR is at room temperature – any temperature between 50 and 100.

At that temperature resistance should be very low between 25 and 50 ohms. Also check resistance to ground, it should be infinite. If the PTCR is good, check the compressor windings.

Measure resistance from Common to ground. It should be infinite. Measure resistance from Common to Run – compare to the chart. Measure resistance from Common to Start – compare to the chart.

Compressor check for high amp draw. Measure amp draw of starting circuit. If it does not drop off immediately after start up, the PTCR should be replaced. It is not practical to check a PTCR for resistance at high temperatures as the resistance drops very fast as the PTCR's temperature falls. If the compressor is drawing excessive amps but is operating, the run capacitor may be open. Disconnect electrical power, discharge the capacitor and measure its resistance. If open, replace it. If shorted to ground, replace it.

Any time the compressor is replaced, the PTCR and run capacitor should also be replaced, or if the model was equipped with a potential relay, start capacitor and run capacitor, those should be replaced with the compressor. Most Scotsman service compressors include those parts.

Some systems use a potential start relay and start capacitor in place of the PTCR.

Potential relay. If the compressor will not start, check the amp draw of the starting circuit. If very low, the potential relay contacts or start capacitor may be open. Measure the resistance of the potential relay contacts and the start capacitor. If either is open it should be replaced. If the compressor starts but draws very high amps from the starting circuit, the potential relay may not switch off. In that case the relay should be replaced.

Test Procedures - Fan motor

1. Test using the controller's indicator lights.

Note: Fan pressure control connection must be jumped to perform this test.

Put the controller into test mode (depress Off for 3 seconds then depress Clean for 3 seconds). At the end of the test cycle, the fan motor will be powered and the Condenser Fan motor indicator light will be on. The fan motor should start and run at that time. If it does not, repeat the test but check the voltage to the fan motor, it must receive full voltage at the fan motor lead connection at the end of the test. If there is voltage and the motor does not operate, replace the motor. If there is no voltage, check the controller high voltage harness connection.

The fan motor lead is the top wire. Check voltage from it to ground, at the end of the test, when the fan motor indicator light is On, there must be voltage from this pin to ground.

Note: high voltage power is supplied to the bottom pin from the contactor line. Refer to the machine wiring diagram as needed.

2. Test using an ohmmeter. Disconnect electrical power. Unplug fan motor from harness. Measure fan motor winding resistance. If open, replace the fan motor.

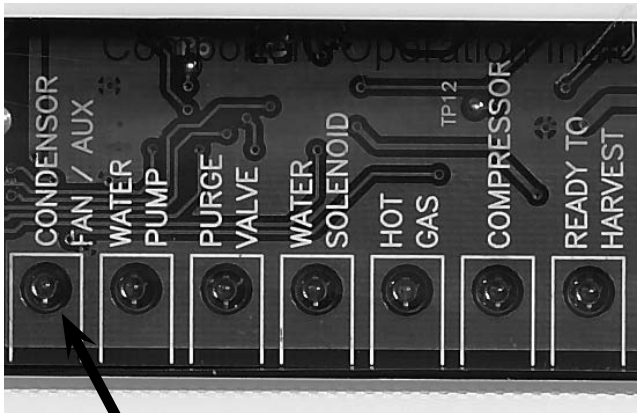

This light is ON when the fan motor should be operating.



Fan Pressure Control, must CLOSE to operate fan motor.

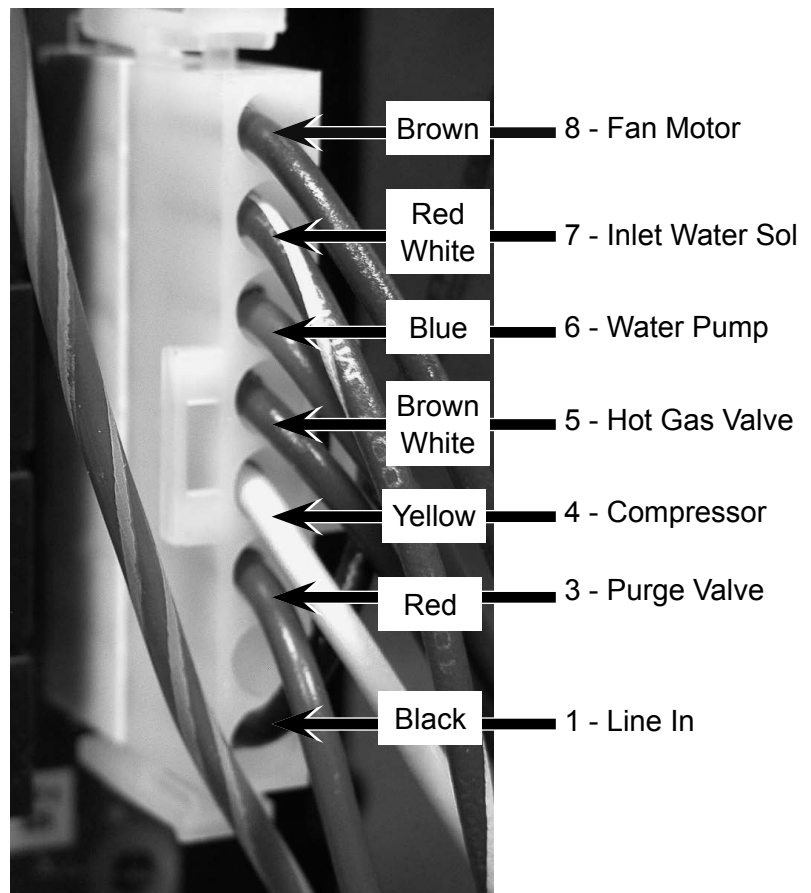

Test Procedures - Water Pump

1. Test using the controller's indicator lights. Check the indicator light during the freeze cycle. The light will be On for all but the 30 second anti-slush period, so observe the light for one minute. When it is On, check the water pump, it should be operating. If not, check voltage to the pump. If low check the voltage from the controller to ground. The water pump pin is number 6. If there is voltage at that pin to ground, but very low voltage at the pump motor, there must be a broken wire in the harness. If the voltage is low at pin 6, the controller should be replaced.

2. Test using an ohmmeter. Disconnect electrical power. Unplug the water pump motor leads from the harness. Measure the resistance of the motor windings. If open, replace the pump. Measure resistance to ground. If there is any, replace the pump.

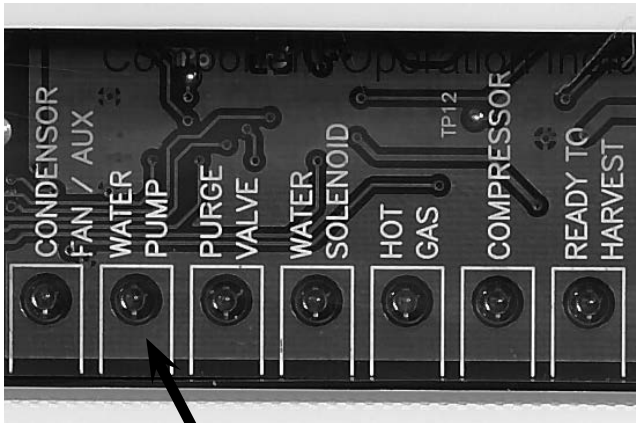

Water Pump light is ON when pump is operating.

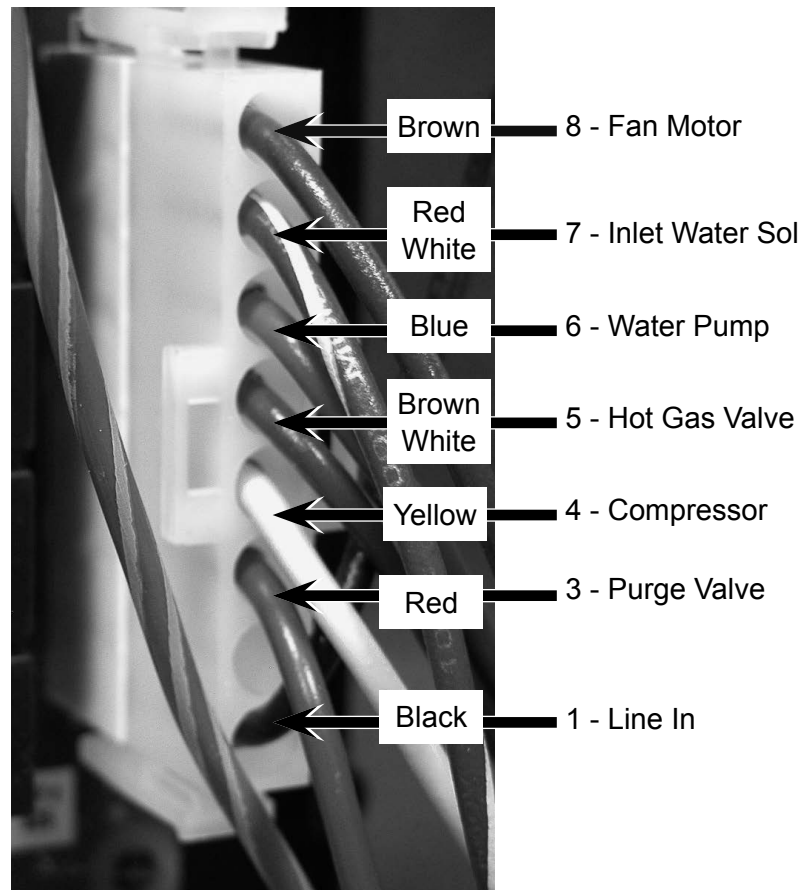

Test Procedure - Purge valve

1. Test using the controller's indicator lights.

- Shut unit off by holding the Off button for 3 seconds. Wait four minutes.
- Push and release the On button, observe the Purge Valve indicator light. As the unit drains the reservoir, the purge valve will be powered. When it gets power, the indicator light will be ON.
- If the purge valve does not open to drain the reservoir when its indicator light is on, do a voltage check. Shut the unit down by holding the Off button in for 3 seconds. Unplug the harness connection from the purge valve.
- Wait four minutes. Push and release the On button to restart the machine.
- As the unit drains the reservoir, the purge valve connection should receive full voltage. If it does, the purge valve should be replaced. If there is no voltage, check voltage from the controller to ground. The purge valve pin is 3 (dump valve on wiring diagram). If there is voltage from that pin to ground, but low voltage at the valve harness connection, the harness has a broken wire or poor connection and must be replaced.
- If the voltage to ground is low, the controller should be replaced.

Note: The coil of this valve is internally rectified, and will normally show infinite resistance when tested with an ohmmeter

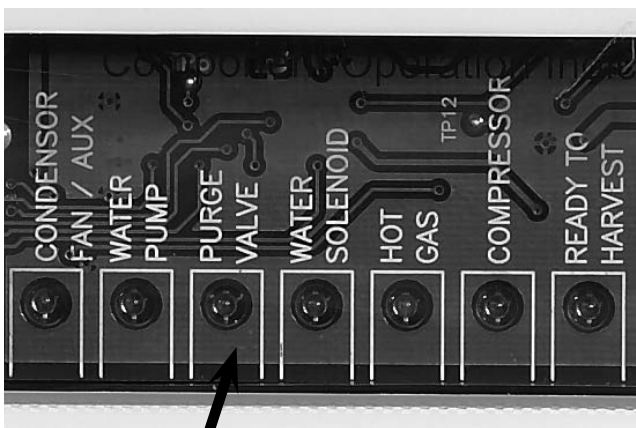

This light will be ON when the Purge Valve is powered.

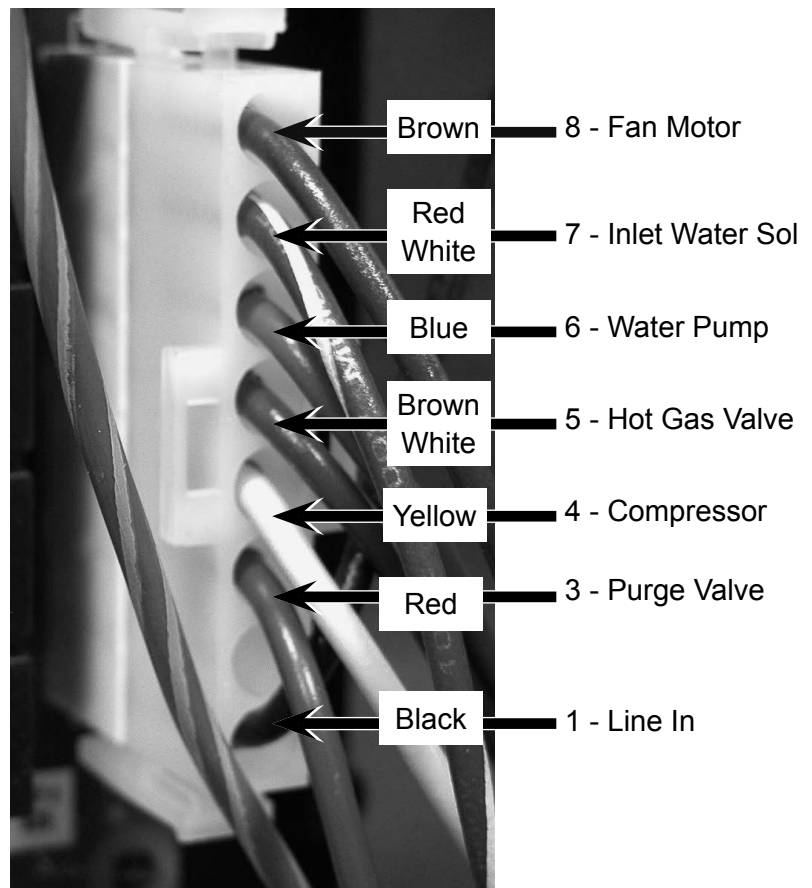

Test Procedure - Compressor contactor

1. Test using the controller's indicator lights. When the unit is in ice making mode (continuous F in the display) the compressor contactor will have power.

- Check the Compressor indicator light, when it is on the compressor contactor will have pulled in. If it is not, do a voltage check.
- Place voltmeter leads on the coil of the contactor. There should be full voltage.
- If there is full voltage present and the contactor has not pulled in, replace the contactor.
- If there is no voltage check if the high pressure cut out is open. If the high pressure cut out is closed, check for voltage from the controller to ground. The contactor pin is 4. Check from 4 to ground, or on 220 volt models, to the other power leg (usually L2) when the compressor indicator light is on. There should be voltage. If not, replace the controller.
- If there is voltage at the controller but not at the contactor coil, the harness wires or connectors are damaged and must be replaced.

2. Test using an ohmmeter. Test the coil of the contactor for continuity or shorts to ground. Replace if open or shorted.

3. Check connections and contacts. Be sure connections are tight and that the contacts are not burnt. Replace any contactor with burnt contacts.

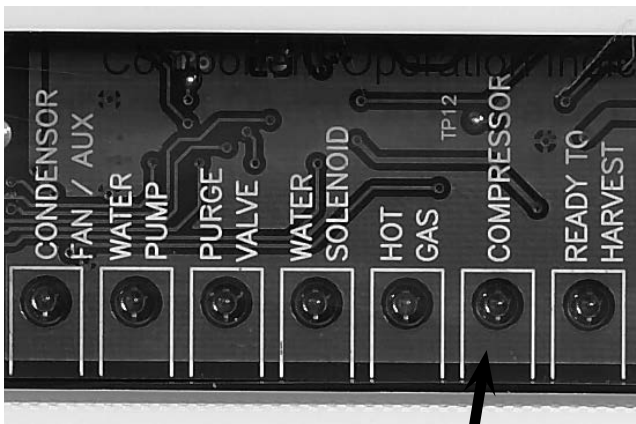

This light is ON when the compressor is operating.

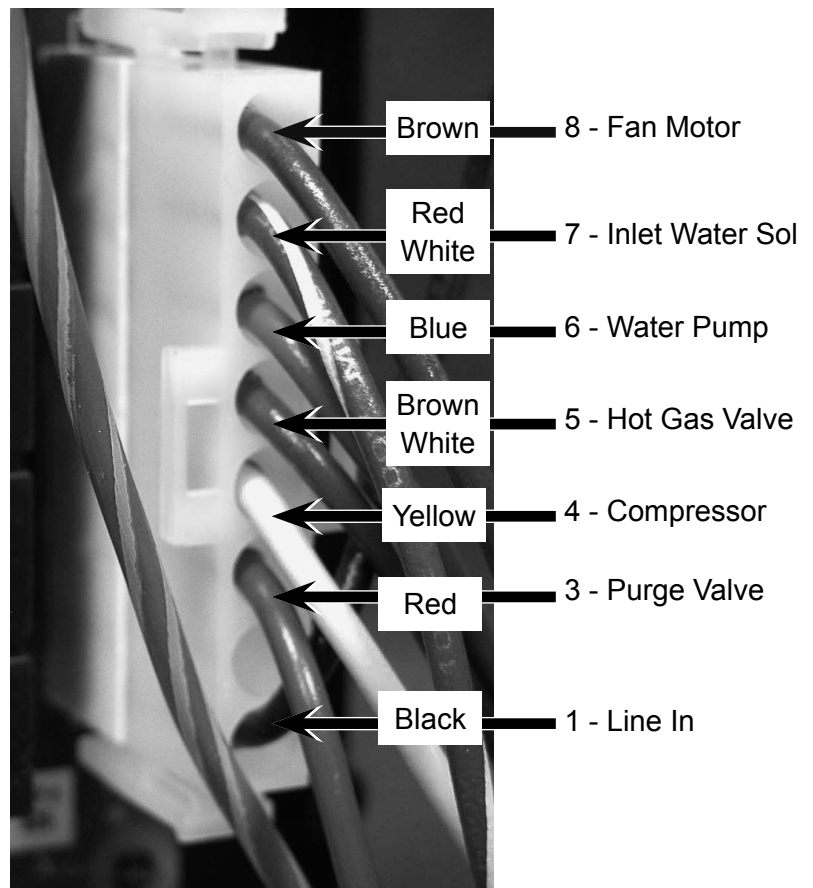

Test Procedures - Pressure switches

There are two pressure switches: Fan and High Pressure cut out.

Fan. The fan pressure switch will open to shut the fan motor off at a certain pressure and re-close at a preset higher pressure.

High pressure cut out. The high pressure cut out switch will open at a preset pressure, shutting off power to the compressor contactor. After the pressure has fallen to another preset level, the switch will re-close and the contactor coil will be energized.

To Test Fan Pressure Switch:

A. Attach refrigeration gauge set to high side port.

B. Unplug both wires from fan pressure control. Be SURE the wire's terminals are wrapped in electrical tape to prevent short circuits to ground during the test.

C. Connect ohmmeter to terminals of fan pressure control..

D. Switch ice machine on, observe pressure that the pressure control closes at, compare to spec. Switch unit off, allow system to equalize, observe pressure the pressure control opens at, compare to spec.

To Test High Pressure Switch:

A. Attach refrigeration gauge set to high side port.

B. Unplug fan motor or shut water off if water cooled.

C. Measure voltage between contactor side terminal of high pressure control and ground.

D. Switch ice machine on, observe pressure that the pressure control opens at, compare to spec. Allow system to equalize, observe the pressure that the pressure control closes at, compare to spec.

Transformer

Check secondary voltage, it must be between 10 and 15.5 AC volts. Replace if no voltage is output or if above or below the acceptable voltage..

Controller

The controller's software operation is confirmed if it is functioning. Execute the test to confirm its operation of the loads. Illumination of a diagnostic code (other than E) is not an indication of controller failure. Each code requires its own diagnosis.

Test Procedures - Liquid Line Solenoid

1. Test using the controller's indicator lights. Put the controller into test mode (depress Off for 3 seconds then depress Clean for 3 seconds). At the end of the test cycle, the liquid line valve will be powered and the Condenser Fan motor indicator light will be on. The liquid line valve should be open at that time.

If it is not, repeat the test but check the voltage to the liquid line valve coil, it must receive full voltage at the liquid line lead connection at the end of the test. If there is voltage and the valve does not operate, replace the valve coil.

If there is no voltage, check the controller high voltage harness connection. The liquid line solenoid lead is the top wire. Check voltage from it to ground, at the end of the test, when the Condenser Fan indicator light is On, there must be voltage from this pin to ground or, on 220 volt models, to the other power leg.

Note: high voltage power is supplied to the bottom pin from the contactor line. Refer to the machine wiring diagram as needed.

2. Test using an ohmmeter. Disconnect electrical power. Unplug liquid line coil from harness. Measure liquid line coil resistance. If open, replace the liquid line valve coil.

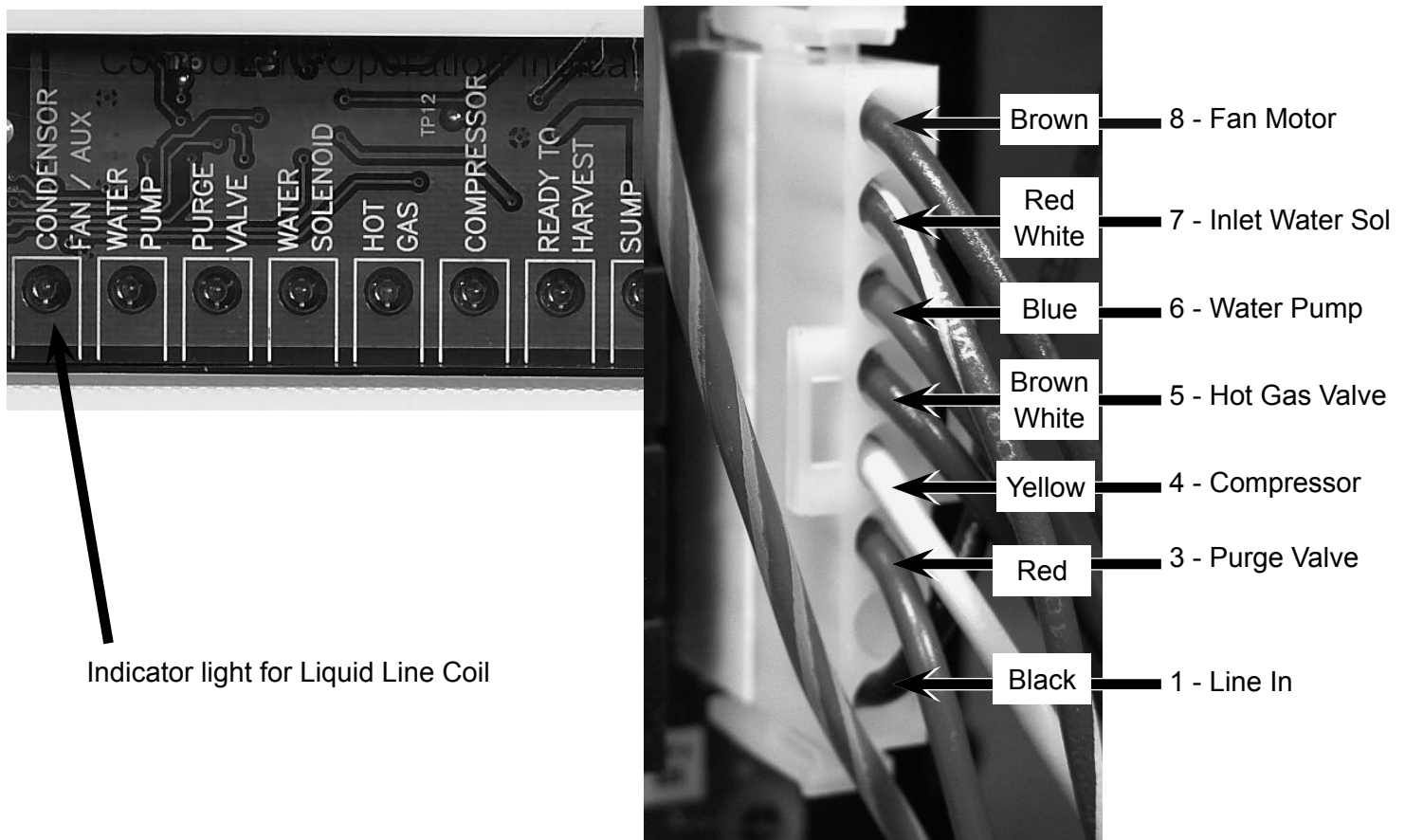

Test Procedure - Inlet Water Solenoid Valve

1. Test using the controller's indicator lights.

Shut unit off by holding the Off button for 3 seconds. Wait four minutes.

Push and release the On button, observe the Water Solenoid indicator light. After the unit drains the reservoir, the inlet water valve will be powered to refill the reservoir. When it gets power, the indicator light will be ON.

If the water valve does not open to fill the reservoir when its indicator light is on, do a voltage check. Shut the unit down by holding the Off button in for 3 seconds. Unplug the harness connection from the inlet water valve. Wait four minutes.

Push and release the On button to restart the machine. After the unit drains the reservoir, the inlet water valve connection should receive full voltage. If it does, the inlet water valve should be replaced.

If there is no voltage, check voltage from the controller. The inlet water solenoid valve pin is 7. If there is voltage from that pin to ground, or on 220 volt models to the other power leg, but low voltage at the valve harness connection, the harness has a broken wire or poor connection and must be replaced. If the voltage to ground or other leg is low, the controller should be replaced.

2. Test using an ohmmeter. Disconnect electrical power. Unplug coil from harness. Measure coil resistance. If open, replace the inlet water solenoid.

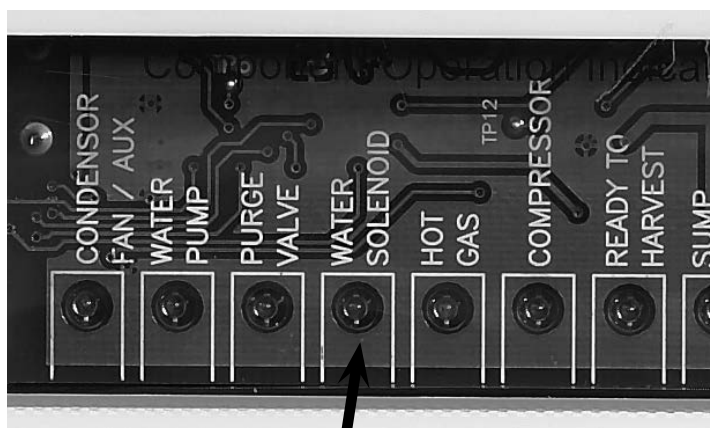

Light is ON when inlet water solenoid is in operation.

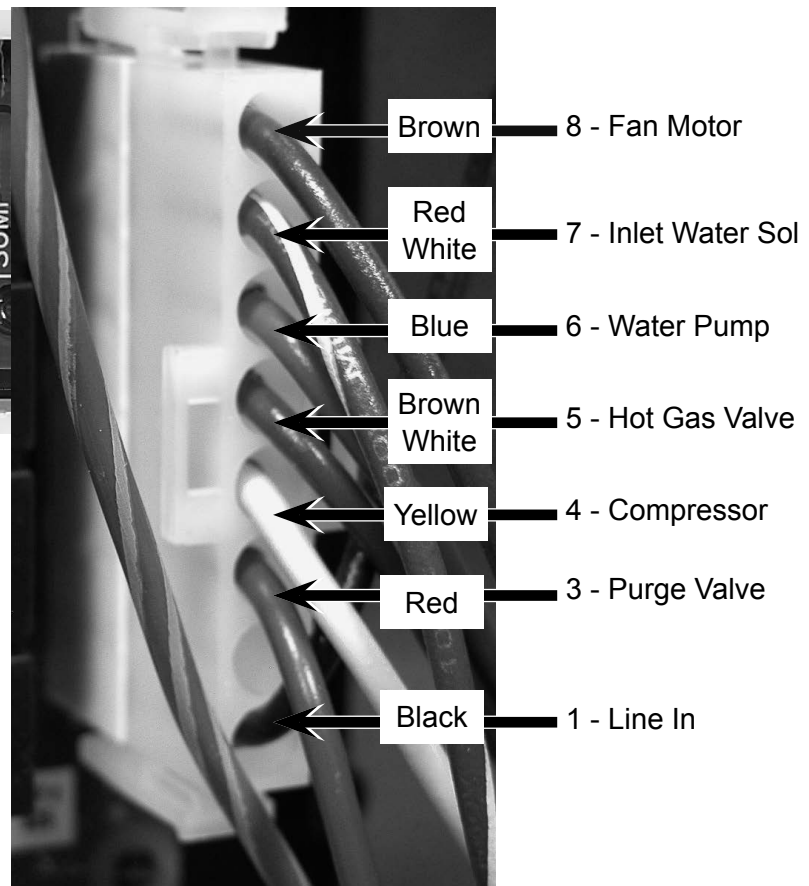

Test Procedure - Harvest Assist

1. Test using the controller's indicator lights. Push and release the Harvest button. The Hot Gas indicator light will be on. At the same time the Harvest Assist Solenoid or Motor will be powered. If the ice on the evaporator is thin, the ejection pin will extend. If the ice is nearly full sized, the pin will press against the ice until it releases from the evaporator, then the pin will extend. If the pin extends, the solenoid or motor is good. If not, do a voltage check.

Unplug the high voltage harness from the harvest assist solenoid. Attach a voltmeter to the harness connector. Push and release the Harvest button. There should be full voltage at the connector.

If there is and the solenoid does not extend, replace the solenoid. If full voltage is not present, check voltage at the controller. If there is no voltage, check voltage from the controller to ground. The hot gas / harvest assist pin is 5.

If there is voltage from that pin to ground, but low voltage at the solenoid harness connection, the harness has a broken wire or poor connection and must be replaced. If the voltage to ground is low, the controller should be replaced.

Note: The coil of this valve is internally rectified, will normally show infinite resistance when tested with an ohmmeter.

Hot Gas or Vapor Valve

1. Test using the controller's indicator lights. If the unit is running, or has been off for more than 4 minutes, push and release the Harvest button. The Hot Gas indicator light will be on and the hot gas valve will be energized. The compressor will force discharge gas into the evaporator inlet, warming it.

If the evaporator inlet does not warm up, do a voltage check. Shut the unit off by holding the Off button in for 3 seconds. Unplug the high voltage harness from the hot gas solenoid. Attach a voltmeter to the harness connector. Wait 4 minutes.

Push and release the Harvest button. There should be full voltage at the connector. If there is and the solenoid does not open, replace the solenoid coil. If full voltage is not present, check voltage at the controller. If there is no voltage, check voltage from the controller to ground or on 220 volt models to the other power leg. The hot gas pin is 5. If there is voltage from that pin to ground, but low voltage at the solenoid harness connection, the harness has a broken wire or poor connection and must be replaced. If the voltage to ground is low, the controller should be replaced.

2. Test with an ohmmeter. Disconnect electrical power. Unplug high voltage harness from hot gas or vapor valve. Measure resistance of hot gas or vapor valve coil. If open, replace the coil.

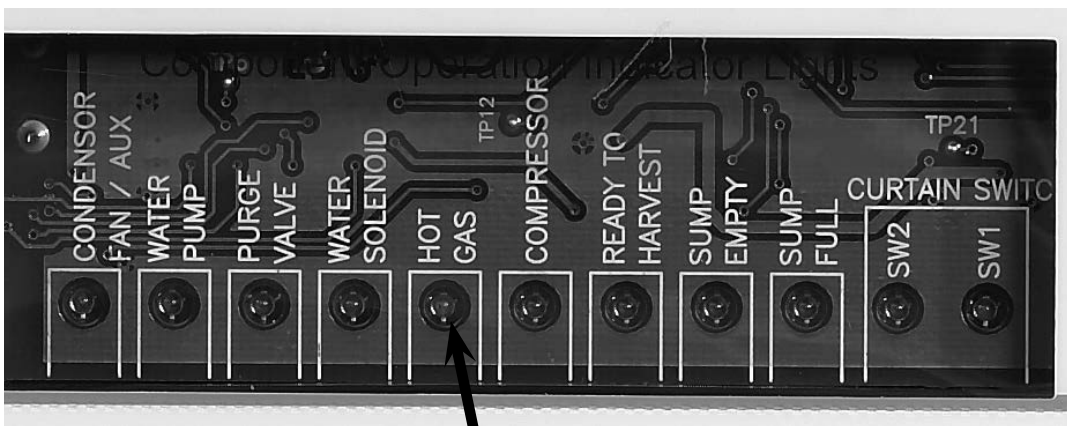

This light will be ON during harvest. Both the Hot Gas Valve coil and the Harvest Assist will have power when this light is ON.

Performance Data - C0322

Model	C0322A	Ambient Air Temp., Degrees F.		
Ice weight / cycle	2.4 to 2.6 lb.	70	80	90
Cycle Time (minutes)	Water Temp			
	50	10-12	12-13	13-14
	70	11-12	13-14	14-16
	80	12-13	14+	15-16
	90	13-14	14-15	16-17
Suction Pressure (PSIG)	End of Freeze	26		32
	Harvest	105		130
Discharge Pressure (PSIG)	End of Freeze	235		250
	Harvest	150		200

Model	C0322W	Ambient Air Temp., Degrees F.		
Ice weight / cycle	2.4 to 2.6 lb	70	80	90
Cycle Time (minutes)	Water Temp			
	50	9-11	11+	10-11
	70	11+	12+	10-12
	80	12+	13+	12-13
	90	12-13	13-14	13+
Suction Pressure (PSIG)	End of Freeze	32		32
	Harvest	95-100		100-110
Discharge Pressure (PSIG)	End of Freeze	245		245
	Harvest	140		150

Suction Pressure Graph

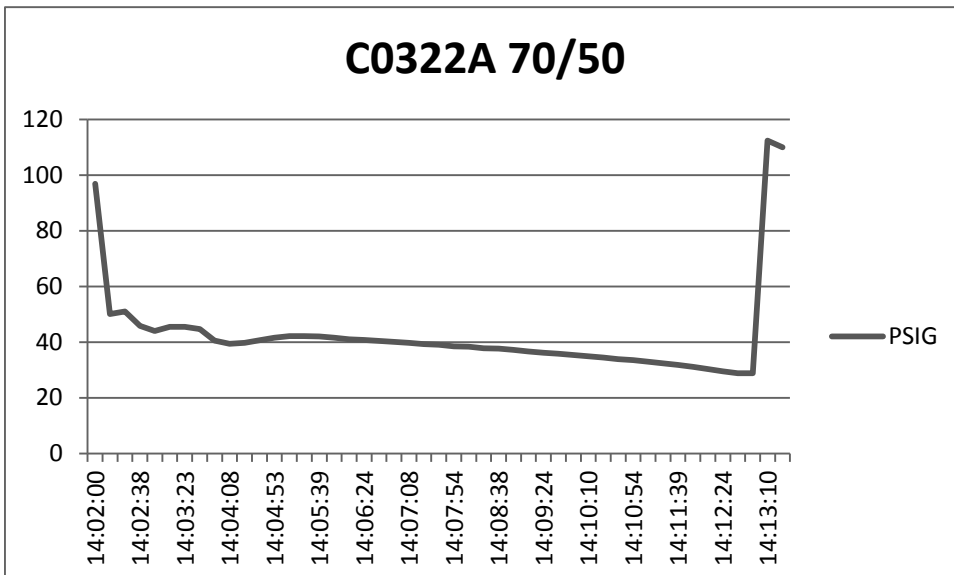

Performance Data - C0522

Model	C0522A	Ambient Air Temp., Degrees F.		
Ice weight / cycle	4.5 to 5 lb.	70	80	90
Cycle Time (minutes)	Water Temp			
	50	11-13	13	16
	70	13	14	16-18
	80	14	15	18
	90	15	16	19
Suction Pressure (PSIG)	End of Freeze	32		34
	Harvest	105		120
Discharge Pressure (PSIG)	End of Freeze	228		270
	Harvest	180		210

Model	C0522W	Ambient Air Temp., Degrees F.		
Ice weight / cycle	4.5 to 5 lb.	70	80	90
Cycle Time (minutes)	Water Temp			
	50	13-15	15	14
	70	15	16	14-15
	80	16	17	15
	90	16-17	17	16
Suction Pressure (PSIG)	End of Freeze	23		36
	Harvest	85		110
Discharge Pressure (PSIG)	End of Freeze	235		245
	Harvest	115		200

Suction Pressure Graph

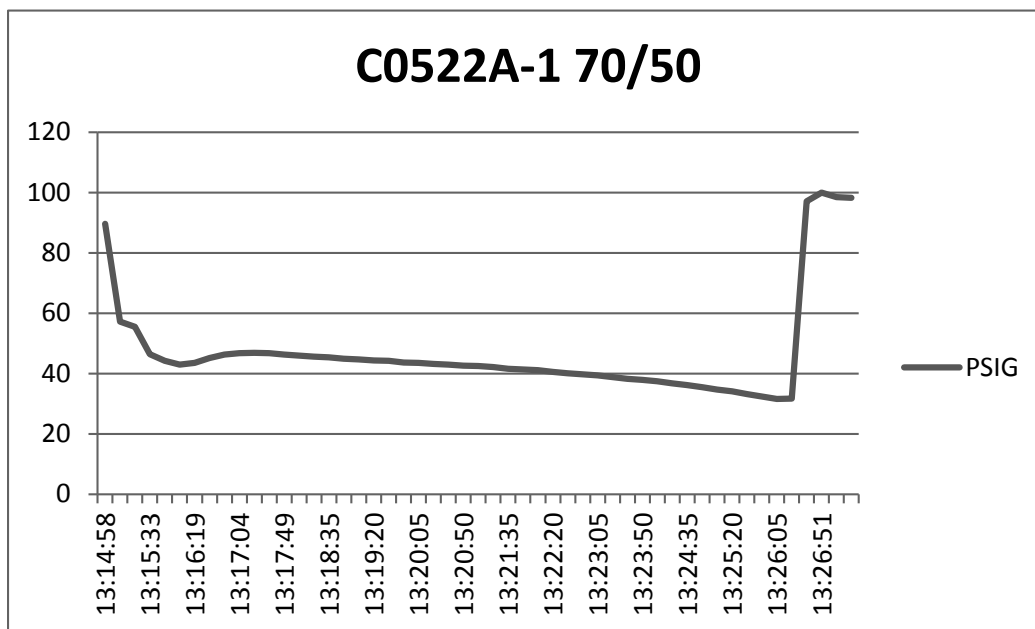

Performance Data - C0722

Model	C0722A	Ambient Air Temp., Degrees F.		
Ice weight / cycle	7.3 to 7.5 lb.	70	80	90
Cycle Time (minutes)	Water Temp			
	50	13	13-14	17
	70	13-14	14	17-18
	80	14-15	15	19-20
	90	15-16	17	21-22
Suction Pressure (PSIG)	End of Freeze	30		33
	Harvest	92-94		150-120
Discharge Pressure (PSIG)	End of Freeze	240-250		310-330
	Harvest	150-155		190-200

Suction Pressure Graph

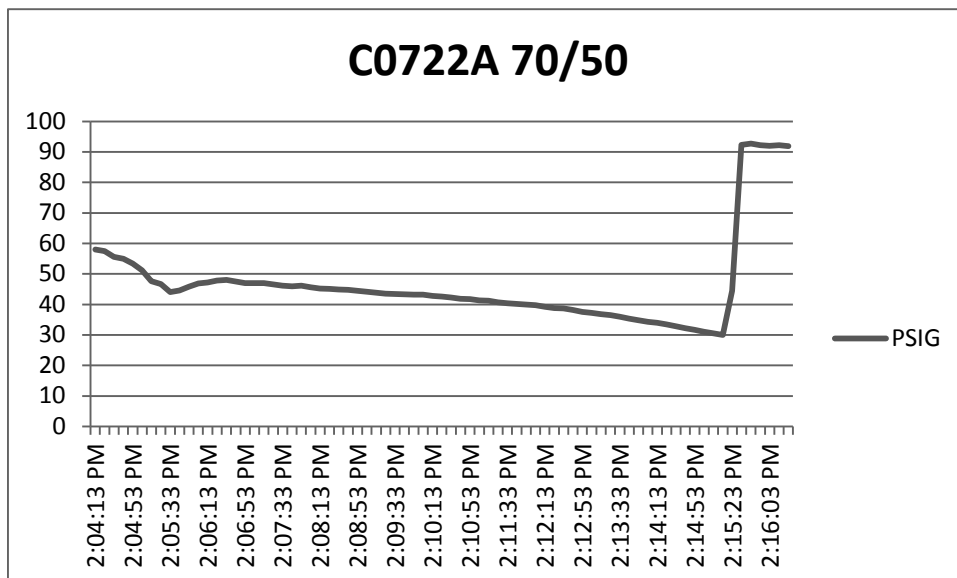

Performance Data - C0330

Model	C0330A	Ambient Air Temp., Degrees F.		
Ice weight / cycle	2.4 to 2.6 lb.	70	80	90
Cycle Time (minutes)	Water Temp			
	50	9-10	10-11	11-12
	70	10-11	11-12	12-13
	80	11-12	12-13	13-14
	90	12-13	13-14	14-15
Suction Pressure (PSIG)	End of Freeze	28		
	Harvest	110		
Discharge Pressure (PSIG)	End of Freeze	200		
	Harvest	150		

Model	C0330W	Ambient Air Temp., Degrees F.		
Ice weight / cycle	2.4 to 2.6 lb.	70	80	90
Cycle Time (minutes)	Water Temp			
	50	11-12	10	10
	70	12-13	11	10-11
	80	13-14	11	11
	90	14-15	11	12
Suction Pressure (PSIG)	End of Freeze	33		35
	Harvest	95		110
Discharge Pressure (PSIG)	End of Freeze	235		235
	Harvest	130		150

Suction Pressure Graph

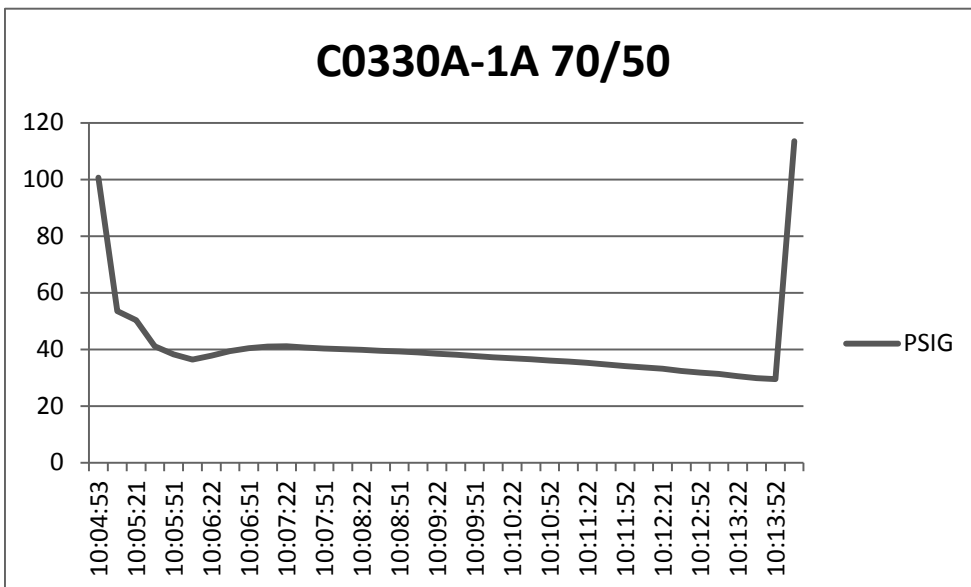

Performance Data - C0530

Model	C0530A	Ambient Air Temp., Degrees F.		
Ice weight / cycle	4.5 to 5 lb.	70	80	90
Cycle Time (minutes)	Water Temp			
	50	13	14	16
	70	14	15	17
	80	15	16	18
Suction Pressure (PSIG)	End of Freeze	33		32
	Harvest	95		105
Discharge Pressure (PSIG)	End of Freeze	230		260
	Harvest	130		190

Model	C0530W	Ambient Air Temp., Degrees F.		
Ice weight / cycle	4.5 to 5 lb.	70	80	90
Cycle Time (minutes)	Water Temp			
	50	10	12	12
	70	11	13	13
	80	12	13	13
Suction Pressure (PSIG)	End of Freeze	33		34
	Harvest	100		110
Discharge Pressure (PSIG)	End of Freeze	235		235
	Harvest	140		150

Suction Pressure Graph

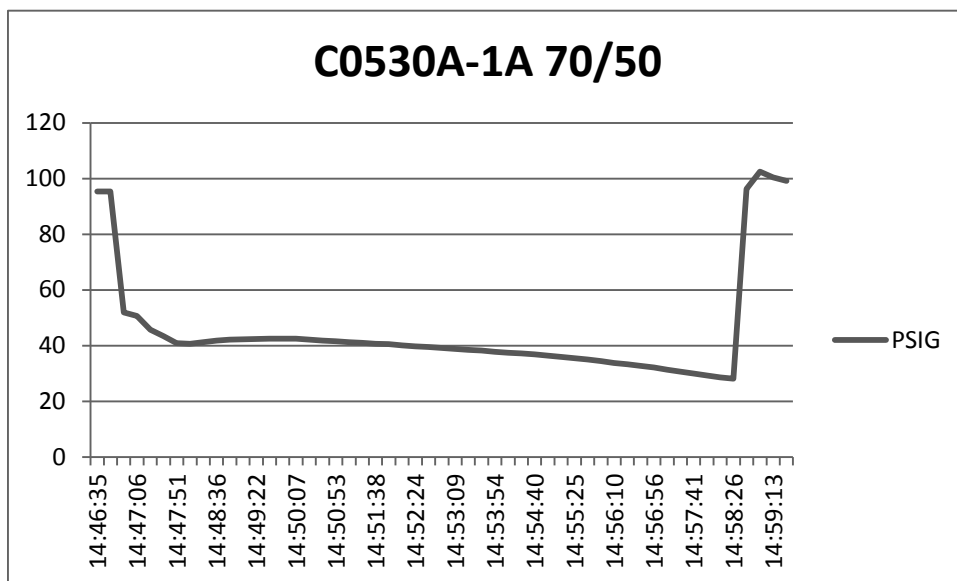

Performance Data - C0630

Model	C0630A	Ambient Air Temp., Degrees F.		
Ice weight / cycle	4.5 to 5 lb.	70	80	90
Cycle Time (minutes)	Water Temp			
	50	9-10	10-11	10-11
	70	10-11	11-12	11-12
	80	11-12	12-13	12-13
	90	12-13	13-14	13-14
Suction Pressure (PSIG)	End of Freeze	21		27
	Harvest	85		115
Discharge Pressure (PSIG)	End of Freeze	200		255
	Harvest	160		200

Model	C0630W	Ambient Air Temp., Degrees F.		
Ice weight / cycle	4.52 to 5 lb.	70	80	90
Cycle Time (minutes)	Water Temp			
	50	9	10	10
	70	10	11	11
	80	11	11	12
	90	11	11	13
Suction Pressure (PSIG)	End of Freeze	25		22
	Harvest	75		80
Discharge Pressure (PSIG)	End of Freeze	235		235
	Harvest	140		155

Suction Pressure Graph

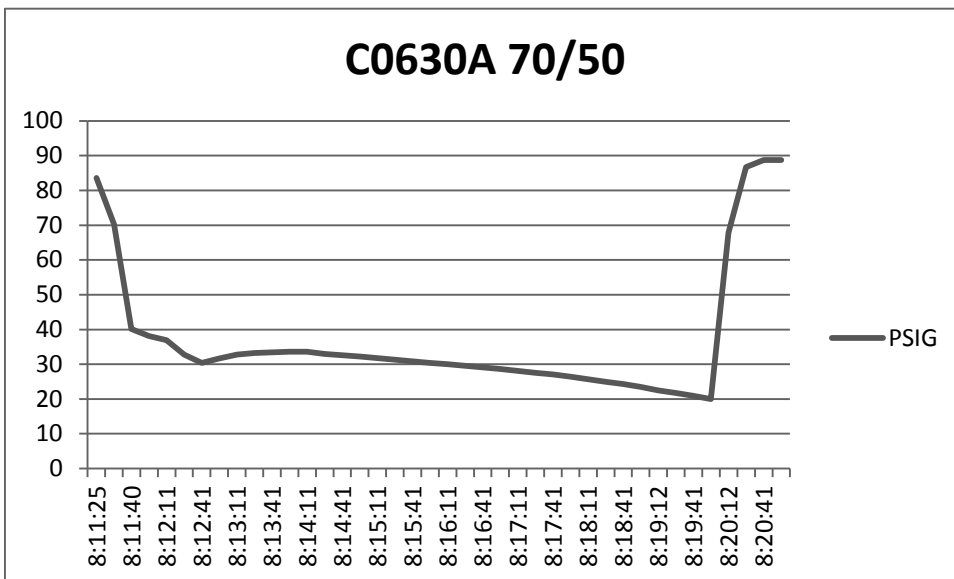

Performance Data - C0830

Model	C0830A	Ambient Air Temp., Degrees F.		
Ice weight / cycle	7 -7.3 lb	70	80	90
Cycle Time (minutes)	Water Temp			
	50	11	12	13
	70	12	13	14
	80	13	14	15
Suction Pressure (PSIG)	End of Freeze	26		30
	Harvest	80		100
Discharge Pressure (PSIG)	End of Freeze	204		260
	Harvest	160		195

Model	C0830W	Ambient Air Temp., Degrees F.		
Ice weight / cycle	7 - 7.3 lb.	70	80	90
Cycle Time (minutes)	Water Temp			
	50	11	12-13	13
	70	12	13-14	13
	80	13	13-14	14
Suction Pressure (PSIG)	End of Freeze	30		31
	Harvest	85		90
Discharge Pressure (PSIG)	End of Freeze	235		237
	Harvest	175		178

Suction Pressure Graph

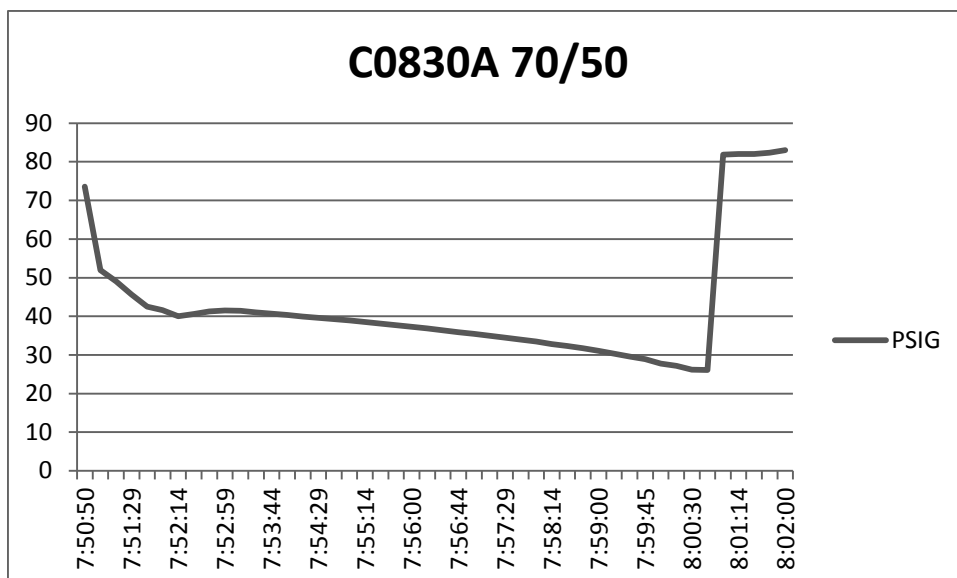

Performance Data - C1030

Model	C1030A	Ambient Air Temp., Degrees F.		
Ice weight / cycle	7 - 7.3 lb	70	80	90
Cycle Time (minutes)	Water Temp			
	50	9-10	10-11	11-12
	70	10-11	11-12	12-13
	80	11-12	12-13	13
	90	10-13	13-14	14-15
Suction Pressure (PSIG)	End of Freeze	26		30
	Harvest	80		90
Discharge Pressure (PSIG)	End of Freeze	210		260
	Harvest	165		190

Model	C1030W	Ambient Air Temp., Degrees F.		
Ice weight / cycle	7 -7.3 lb.	70	80	90
Cycle Time (minutes)	Water Temp			
	50	10	11	11
	70	11	11-12	11
	80	11-12	12	12
	90	12	12-13	13
Suction Pressure (PSIG)	End of Freeze	26		30
	Harvest	70		75
Discharge Pressure (PSIG)	End of Freeze	240		240
	Harvest	145		155

Suction Pressure Graph

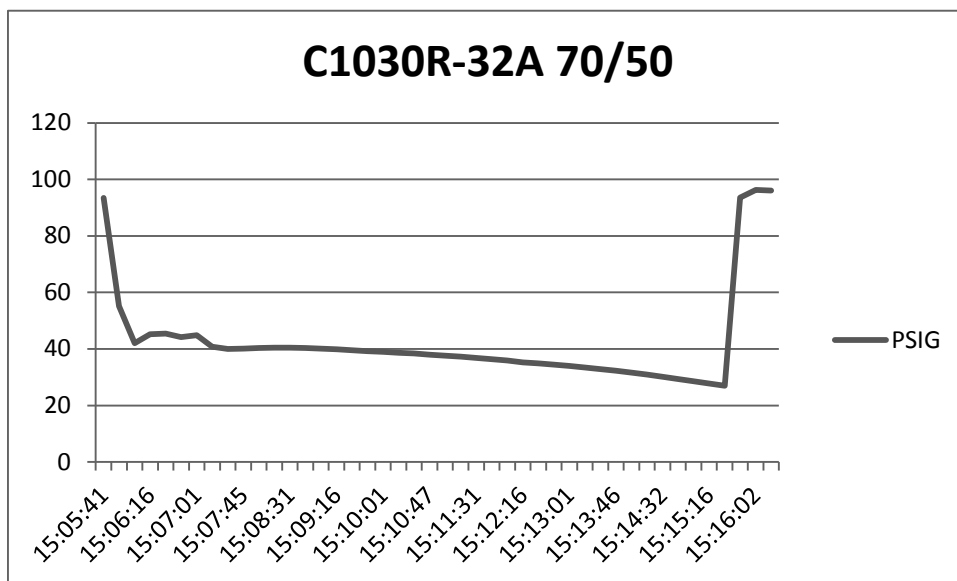

Performance Data - C1448

Model	C1448A	Ambient Air Temp., Degrees F.		
Ice weight / cycle	14 lb.	70	80	90
Cycle Time (minutes)	Water Temp			
	50	12-13	13-14	14-15
	70	13-14	14-15	15-16
	80	14-15	15-16	16-17
	90	15-16	16-17	17-18
Suction Pressure (PSIG)	End of Freeze	38		40
	Harvest	100		100
Discharge Pressure (PSIG)	End of Freeze	250		270
	Harvest	150		160

Model	C1448W	Ambient Air Temp., Degrees F.		
Ice weight / cycle	14 lb.	70	80	90
Cycle Time (minutes)	Water Temp			
	50	13-14	14-15	15-16
	70	14-15	15-16	15-16
	80	15-16	15-16	16-17
	90	15-16	15-16	17-18
Suction Pressure (PSIG)	End of Freeze	36		35
	Harvest	105		100
Discharge Pressure (PSIG)	End of Freeze	235		235
	Harvest	170		185

Suction Pressure Graph

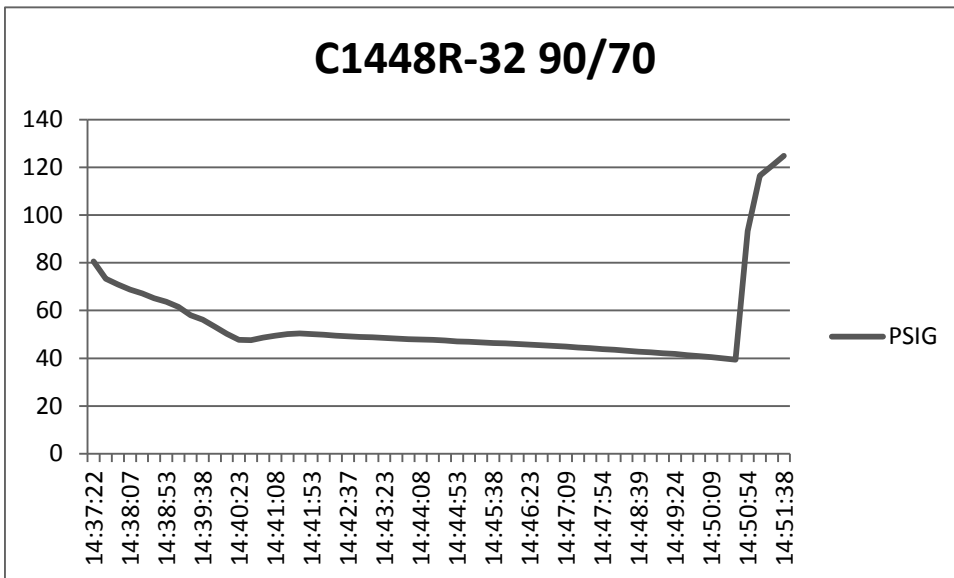

Performance Data - C1848

Model	C1848A	Ambient Air Temp., Degrees F.		
Ice weight / cycle	14 lb.	70	80	90
Cycle Time (minutes)	Water Temp			
	50	10-11	11-12	12-13
	70	11-12	12-13	13-14
	80	12-13	13-14	14-15
	90	13-14	14-15	15-16
Suction Pressure (PSIG)	End of Freeze	30		32
	Harvest	90		100
Discharge Pressure (PSIG)	End of Freeze	227		285
	Harvest	170		195

Model	C1848W	Ambient Air Temp., Degrees F.		
Ice weight / cycle	14 lb.	70	80	90
Cycle Time (minutes)	Water Temp			
	50	10-11	11-12	11-12
	70	11-12	12-13	11-12
	80	12-13	12-13	12-13
	90	12-13	12-13	13-14
Suction Pressure (PSIG)	End of Freeze	30		30
	Harvest	80		85
Discharge Pressure (PSIG)	End of Freeze	240		240
	Harvest	155		165

Suction Pressure Graph

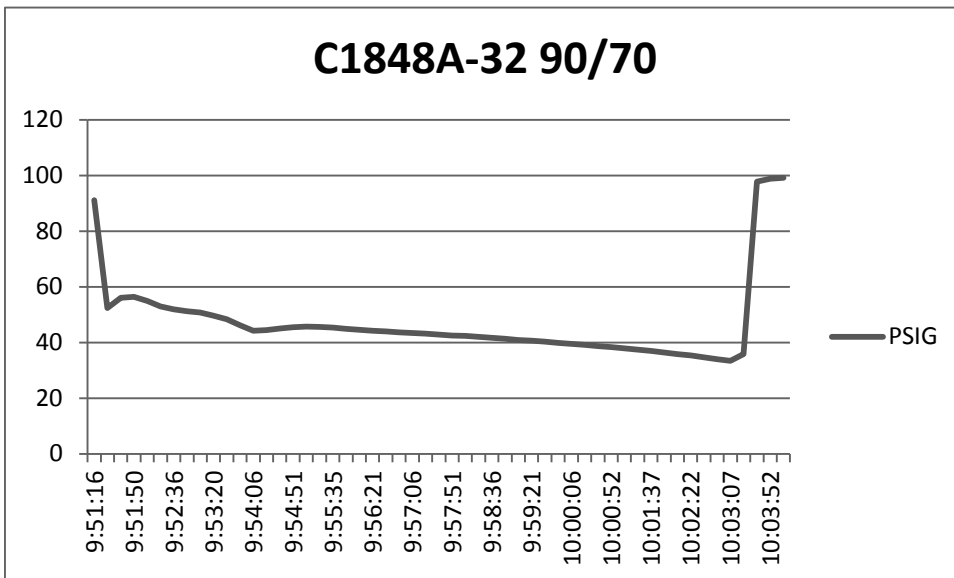

Performance Data - C2148

Model	C2148R	Ambient Air Temp., Degrees F.				
Ice weight / cycle	14.2 lb.	-20	70	80	90	120
Cycle Time (minutes)	Water Temp					
	50	9	10	10	11	
	70		9-10	10	12	
	80		11-12	11	13	
	90		12-13	14	15-16	18-19
Suction Pressure (PSIG)	End of Freeze		24		24	
	Harvest		80		95	
Discharge Pressure (PSIG)	End of Freeze		240		250	
	Harvest		190		220	peak 410

Model	C2148W	Ambient Air Temp., Degrees F.		
Ice weight / cycle	14.2 lb	70	80	90
Cycle Time (minutes)	Water Temp			
	50	9-10	10-11	11
	70	10-11	11-12	11
	80	11-12	11-12	12
	90	11-12	11-12	13
Suction Pressure (PSIG)	End of Freeze	27		27
	Harvest	75		75
Discharge Pressure (PSIG)	End of Freeze	235		240
	Harvest	160		160

Suction Pressure Graph

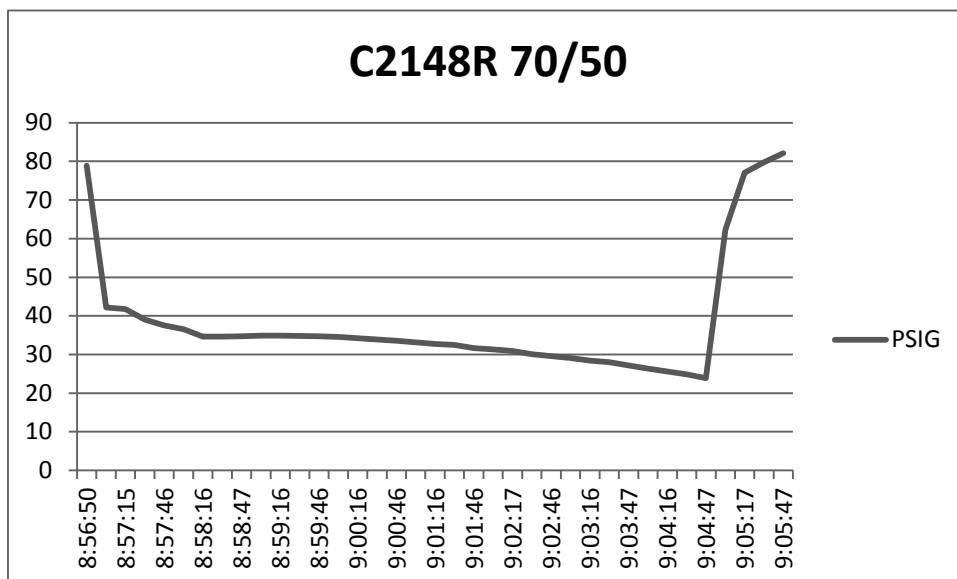

Performance Data Remote - C0522, C0530

Model	C0522R	Ambient Air Temp., Degrees F.				
Ice weight / cycle	4.4 to 4.6 lb.	-20	70	80	90	120
Cycle Time (minutes)	Water Temp	10				
	50		12-13	13-14	14	
	70		13-14	13-14	14-15	
	80		14-15	14-15	15-16	23
	90		15-16	17-18	18-19	
Suction Pressure (PSIG)	End of Freeze		35		24	
	Harvest		85		95	
Discharge Pressure (PSIG)	End of Freeze		230		245	
	Harvest		215		225	peak 360

Model	C0530R	Ambient Air Temp., Degrees F.				
Ice weight / cycle	4.4 to 4.6 lb.	-20	70	80	90	120
Cycle Time (minutes)	Water Temp	10				
	50		11-13	13-14	13-14	
	70		14	14-15	14	
	80		15	15-16	15-16	
	90		16	17-18	17-18	27
Suction Pressure (PSIG)	End of Freeze		30		35	
	Harvest		145		100	
Discharge Pressure (PSIG)	End of Freeze		230		245	
	Harvest		200		220	Peak 350

Performance Data Remote - C0630, C0830, C1030

Model	C0630R	Ambient Air Temp., Degrees F.				
Ice weight / cycle	4.4 to 4.6 lb.	-20	70	80	90	120
Cycle Time (minutes)	Water Temp	7-8	9	9	9-10	16-17
	50					
	70					
	80					
	90	12	14	13-14		
Suction Pressure (PSIG)	End of Freeze		30		30	
	Harvest		110		120	
Discharge Pressure (PSIG)	End of Freeze		240		245	
	Harvest		200		220	Peak 370

Model	C0830R	Ambient Air Temp., Degrees F.				
Ice weight / cycle	7 -7.3 lb	-20	70	80	90	120
Cycle Time (minutes)	Water Temp	8-9	9-11	10-11	12	21-22
	50					
	70					
	80					
	90	13-14	15	16-17		
Suction Pressure (PSIG)	End of Freeze		32		32	
	Harvest		100		110	
Discharge Pressure (PSIG)	End of Freeze		240		245	
	Harvest		200		210	Peak 360

Model	C1030R	Ambient Air Temp., Degrees F.				
Ice weight / cycle	7 -7.3 lb	-20	70	80	90	120
Cycle Time (minutes)	Water Temp	9	10-11	11	12-13	20-21
	50					
	70					
	80					
	90	13-14	15-16	16-17		
Suction Pressure (PSIG)	End of Freeze		28		27	
	Harvest		95		100	
Discharge Pressure (PSIG)	End of Freeze		230		240	
	Harvest		200		215	Peak 380

Performance Data Remote - C1448, C1848

Model	C1448R	Ambient Air Temp., Degrees F.				
Ice weight / cycle	14 lb.	-20	70	80	90	120
Cycle Time (minutes)	Water Temp	9				
	50		11	11-12	14-15	
	70		11-12	11-12	14-15	
	80		13	13	16	
	90		14	15-16	18-19	22
Suction Pressure (PSIG)	End of Freeze		40		40	
	Harvest		100		125	
Discharge Pressure (PSIG)	End of Freeze		240		270	
	Harvest		150		200	Peak 405

Model	C1848R	Ambient Air Temp., Degrees F.				
Ice weight / cycle	14 lb.	-20	70	80	90	120
Cycle Time (minutes)	Water Temp	9				
	50		10-11	11-12	13	
	70		11-12	12	13	
	80		13	13-14	14-15	
	90		14	16	17	19
Suction Pressure (PSIG)	End of Freeze		32		33	
	Harvest		85		105	
Discharge Pressure (PSIG)	End of Freeze		240		245	
	Harvest		170		2005	Peak 370

Wiring Diagrams

USE COPPER CONDUCTORS ONLY

17-3053-01

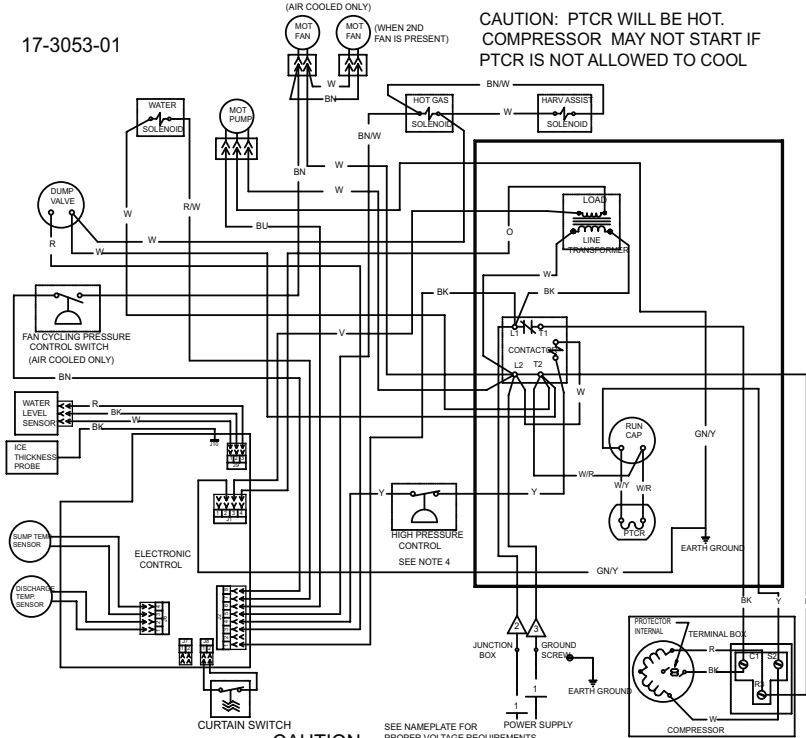

- ⚠ DASHED LINES INDICATE FIELD WIRING WHICH MUST BE INSTALLED IN ACCORDANCE WITH THE NATIONAL ELECTRICAL CODE AND ALL STATE AND LOCAL CODES.
- ⚠ WIRE COLOR FOR 208-230/60/1 AND 115/60/1 UNITS: BLACK
- ⚠ WIRE COLOR FOR 115/60/1 UNITS: WHITE
- ⚠ WIRE COLOR FOR 208-230/60/1 UNITS: BLACK W/WHITE STRIPE
- ⚠ HIGH PRESSURE CONTROL USED ON WC UNITS & AC C0222, C0422, C0230, C0530, C0630

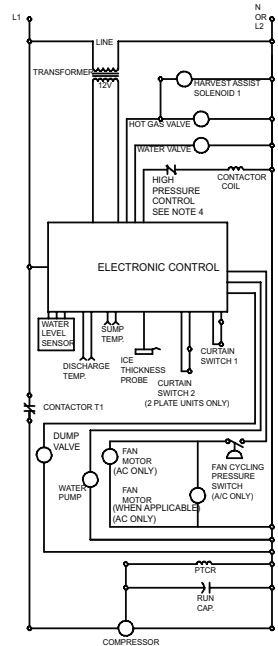

THIS UNIT MUST BE GROUNDING.

CAUTION: MORE THAN ONE DISCONNECT MEANS MAY BE REQUIRED TO DISCONNECT ALL POWER TO THIS UNIT.

C0322, C0522, C0722, C0330, C0530, C0630, C0830, C1030 - Single Phase A - B Series

17-3508-01

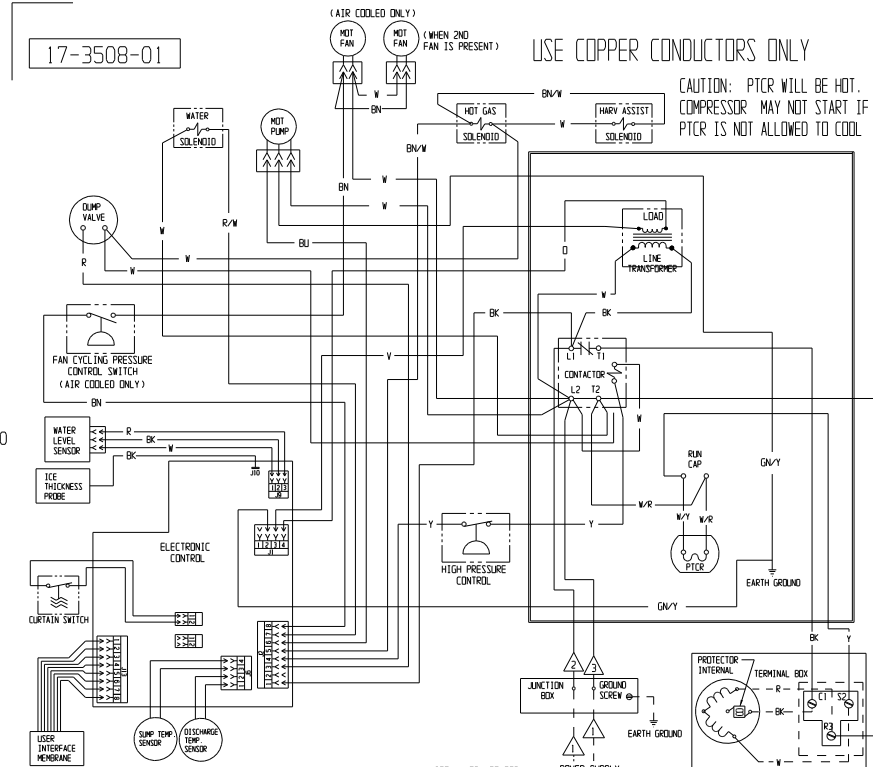

- ⚠ DASHED LINES INDICATE FIELD WIRING WHICH MUST BE INSTALLED IN ACCORDANCE WITH THE NATIONAL ELECTRICAL CODE AND ALL STATE AND LOCAL CODES.
- ⚠ WIRE COLOR FOR 208-230/60/1 AND 115/60/1 UNITS: BLACK
- ⚠ WIRE COLOR FOR 115/60/1 UNITS: WHITE
- ⚠ WIRE COLOR FOR 208-230/60/1 UNITS: BLACK W/WHITE STRIPE

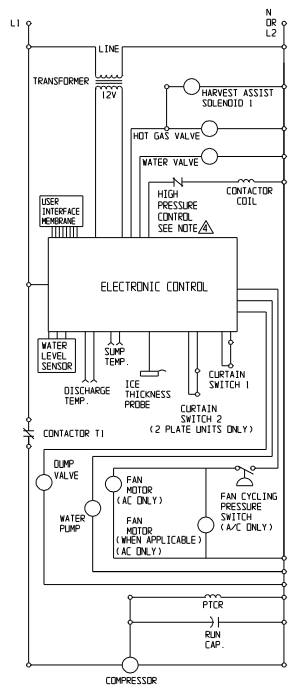

THIS UNIT MUST BE GROUNDING.

CAUTION: MORE THAN ONE DISCONNECT MEANS MAY BE REQUIRED TO DISCONNECT ALL POWER TO THIS UNIT.

C0322, C0522, C0722, C0630, C0830, C1030 - Single Phase D Series

Wiring Diagrams

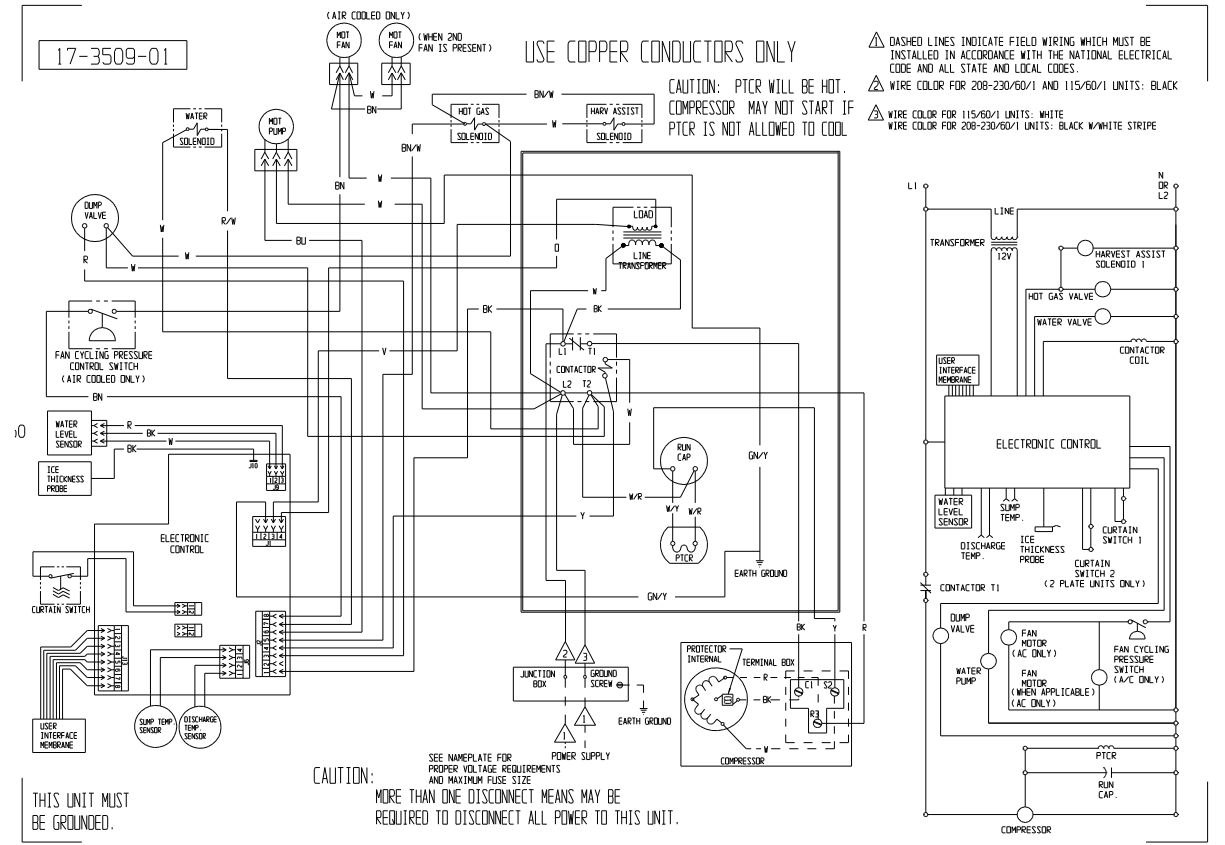
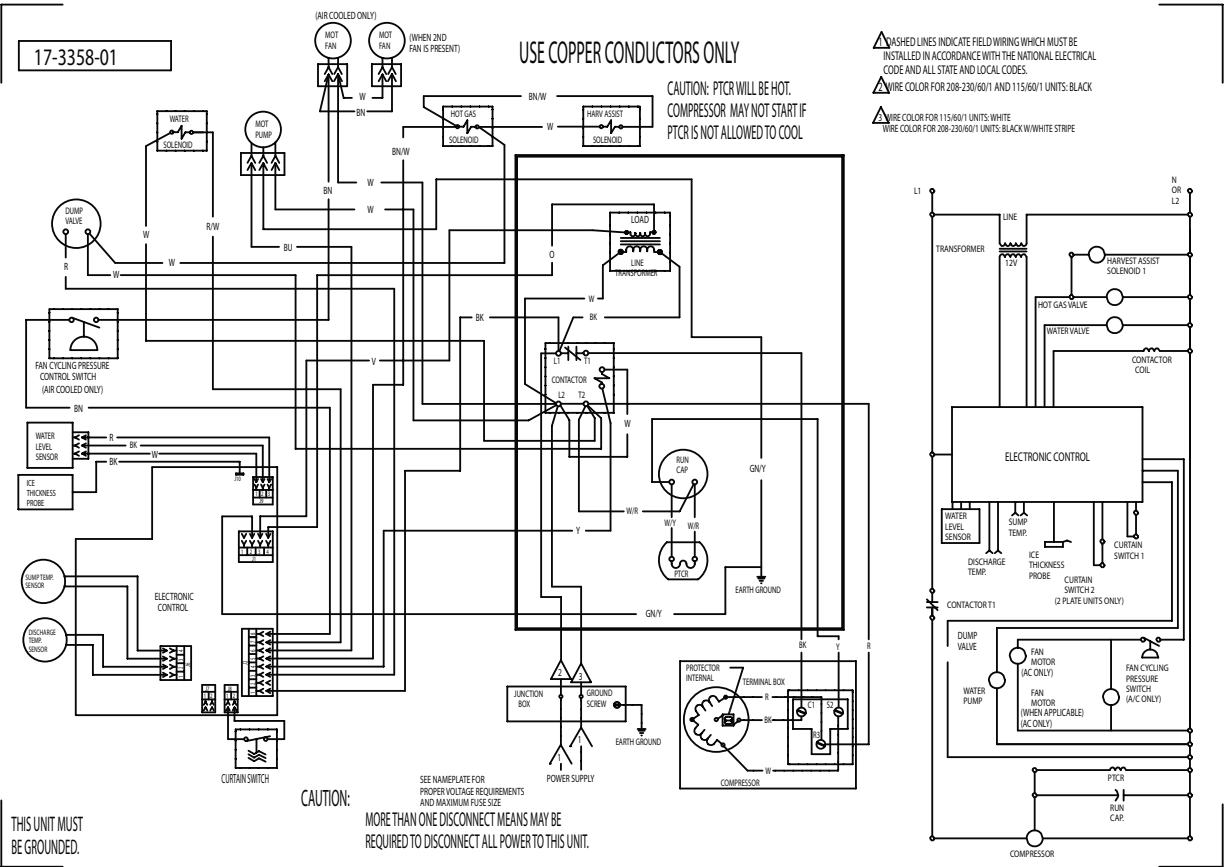

C0330 and C0530 D Series

Wiring Diagrams

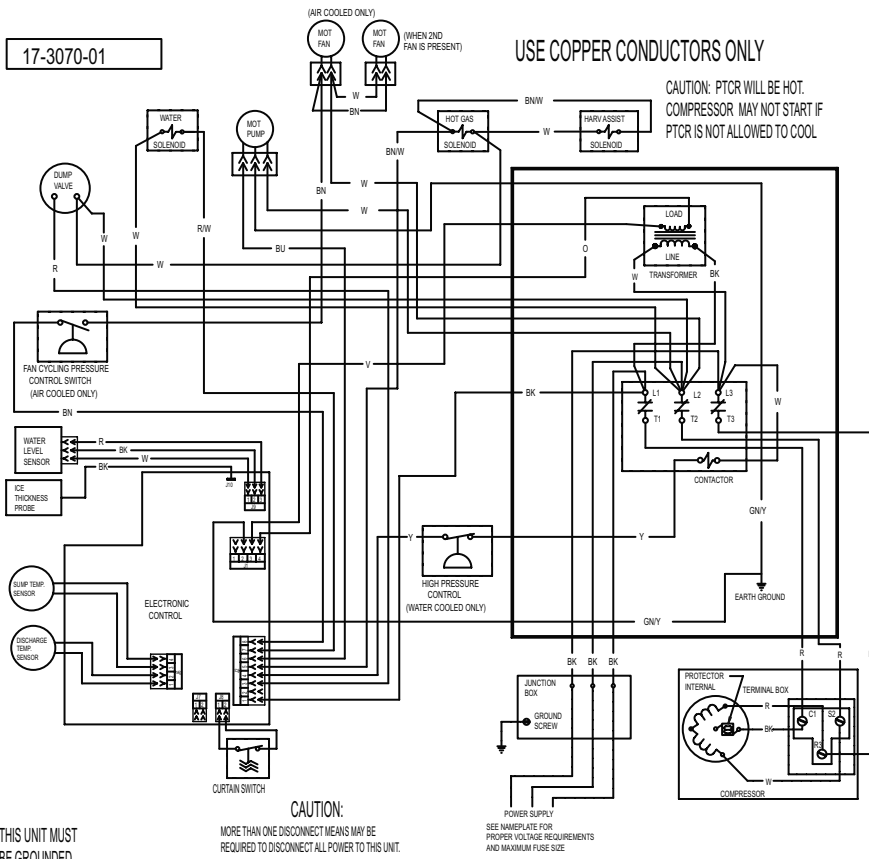

△ DASHED LINES INDICATE FIELD WIRING WHICH MUST BE INSTALLED IN ACCORDANCE WITH THE NATIONAL ELECTRICAL CODE AND ALL STATE AND LOCAL CODES.

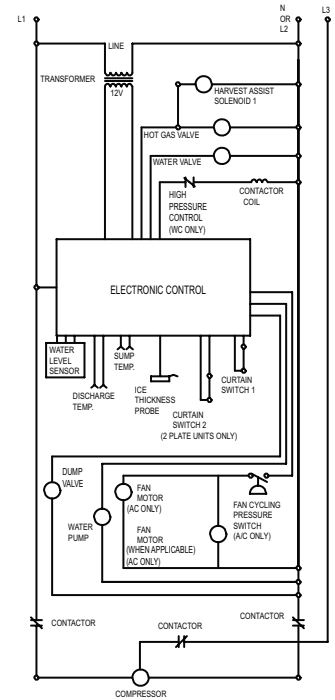

C0830, C1030 Three Phase A - B Series

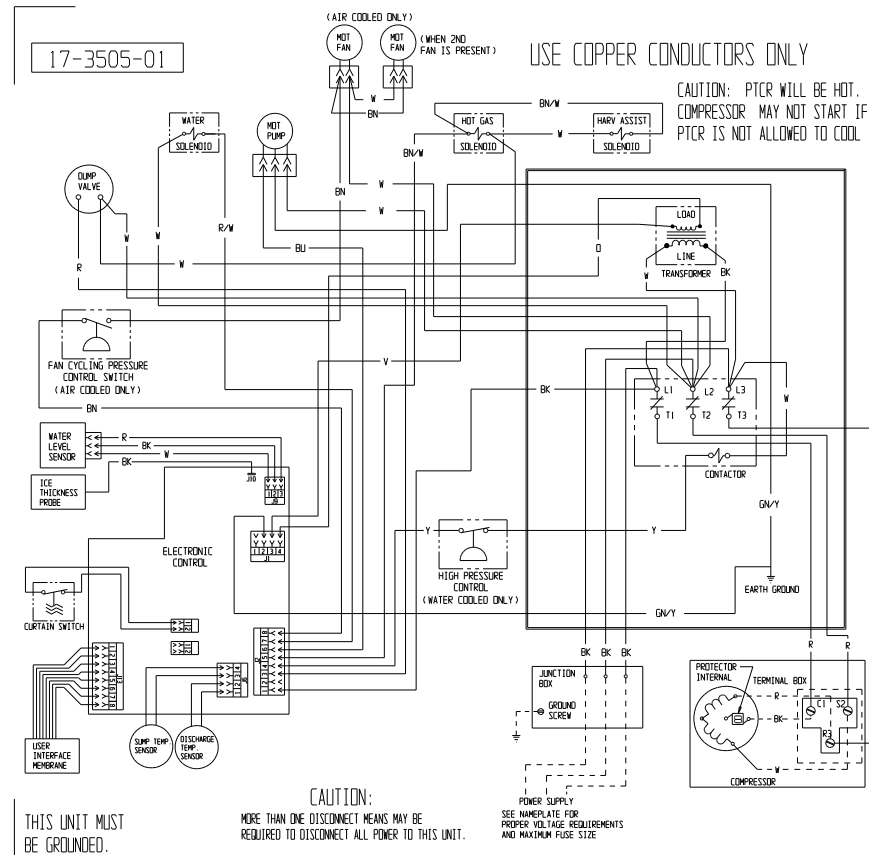

△ DASHED LINES INDICATE FIELD WIRING WHICH MUST BE INSTALLED IN ACCORDANCE WITH THE NATIONAL ELECTRICAL CODE AND ALL STATE AND LOCAL CODES.

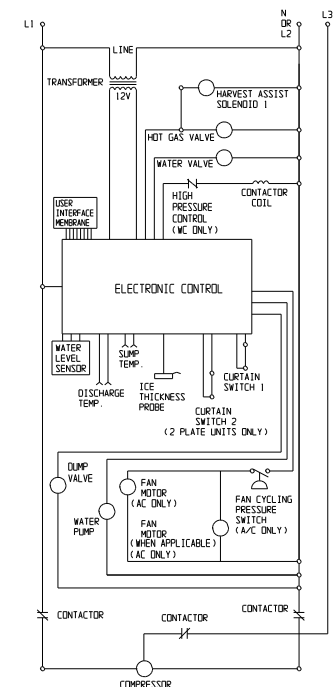

C0830, C1030 Three Phase D Series

Wiring Diagrams

17-3055-01

USE COPPER CONDUCTORS ONLY

- ⚠ DASHED LINES INDICATE FIELD WIRING WHICH MUST BE INSTALLED IN ACCORDANCE WITH THE NATIONAL ELECTRICAL CODE AND ALL STATE AND LOCAL CODES.
- ⚠ WIRE COLOR FOR 208-230/60/1 AND 115/60/1 UNITS: BLACK
- ⚠ WIRE COLOR FOR 115/60/1 UNITS: WHITE
- ⚠ WIRE COLOR FOR 208-230/60/1 UNITS: BLACK W/WHITE STRIPE

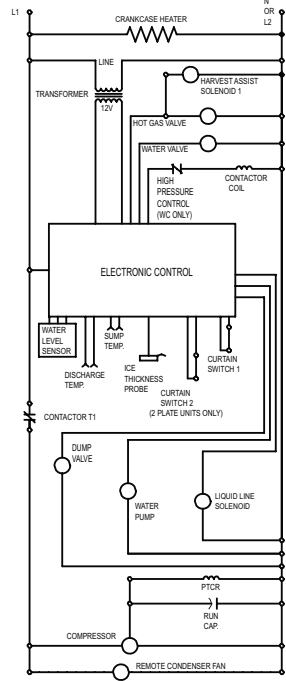
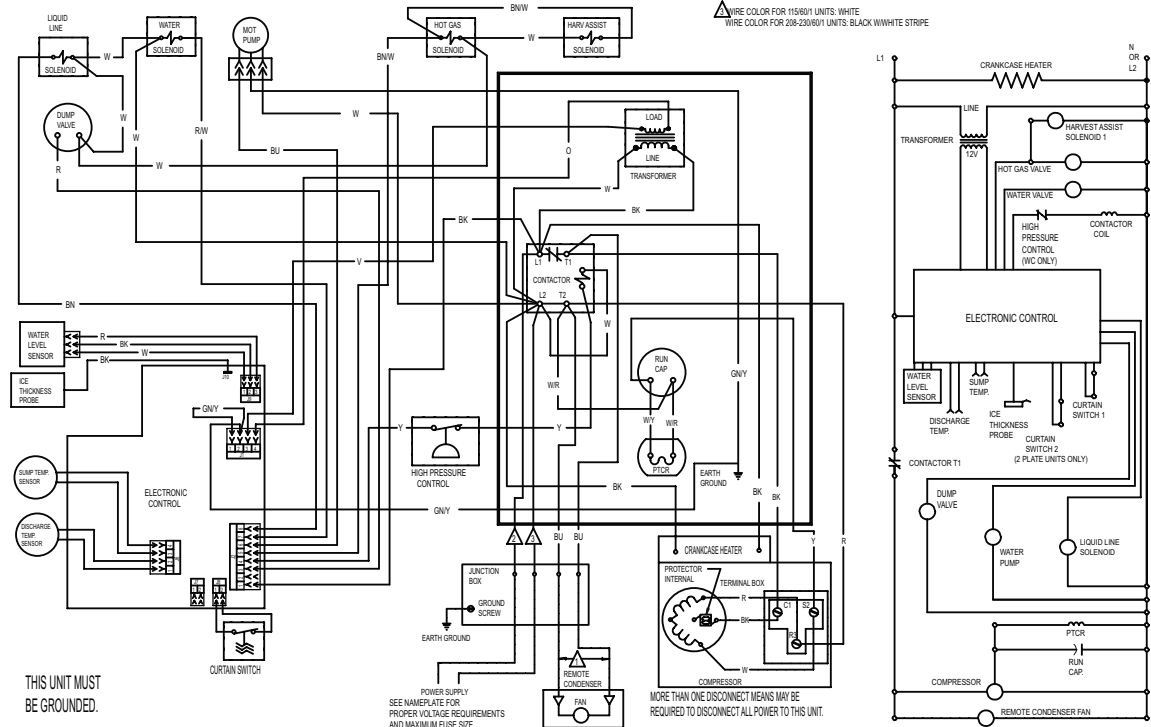

C0522R, C0530R, C0630R, C0830R, C1030R - Single Phase A - B Series

17-3506-01

USE COPPER CONDUCTORS ONLY

- ⚠ DASHED LINES INDICATE FIELD WIRING WHICH MUST BE INSTALLED IN ACCORDANCE WITH THE NATIONAL ELECTRICAL CODE AND ALL STATE AND LOCAL CODES.
- ⚠ WIRE COLOR FOR 208-230/60/1 AND 115/60/1 UNITS: BLACK
- ⚠ WIRE COLOR FOR 115/60/1 UNITS: WHITE
- ⚠ WIRE COLOR FOR 208-230/60/1 UNITS: BLACK W/WHITE STRIPE

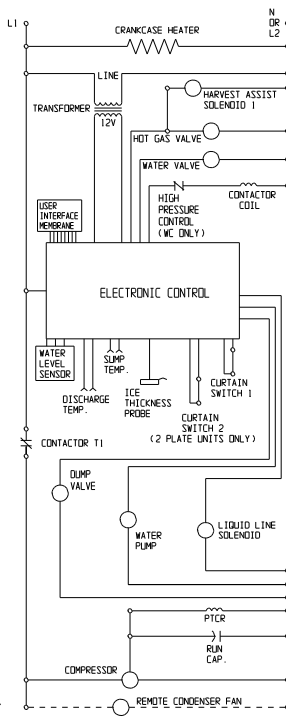
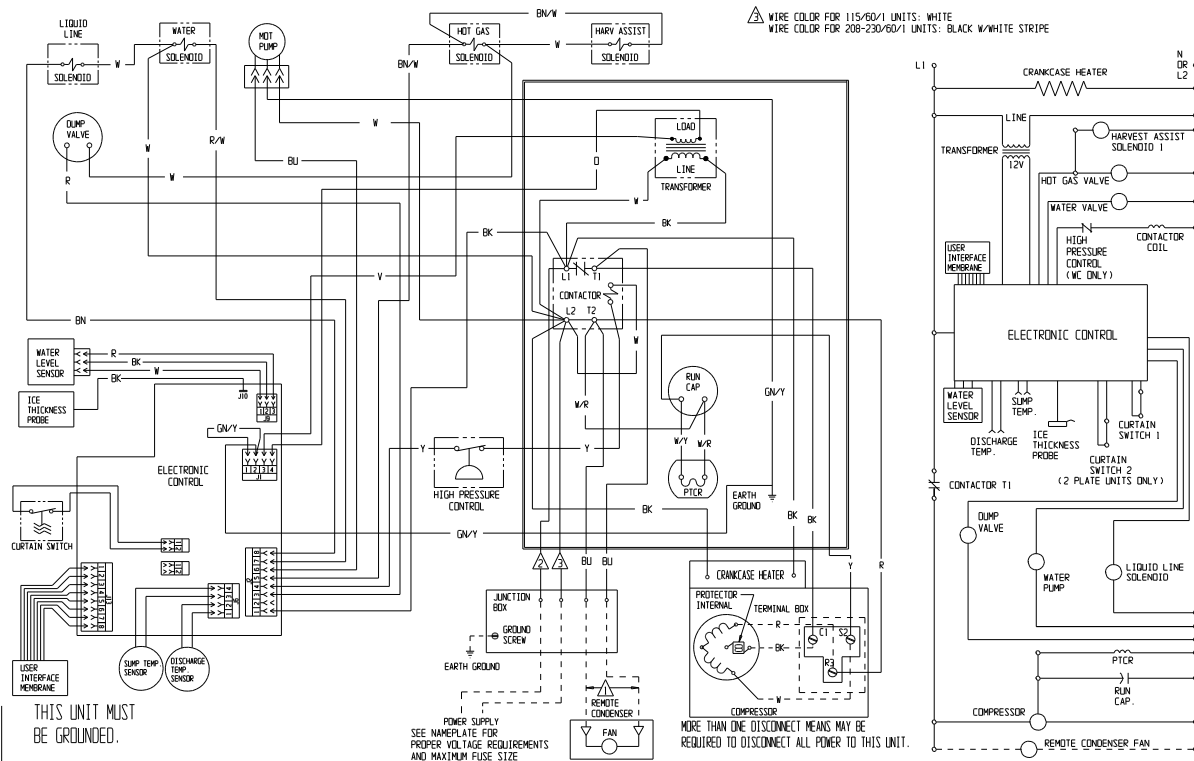

C0630R, C0830R, C1030R - Single Phase D Series

Wiring Diagrams

17-3359-01

USE COPPER CONDUCTORS ONLY

- ▲ DASHED LINES INDICATE FIELD WIRING WHICH MUST BE INSTALLED IN ACCORDANCE WITH THE NATIONAL ELECTRICAL CODE AND ALL STATE AND LOCAL CODES.
- ▲ WIRE COLOR FOR 208-230/60/1 AND 115/60/1 UNITS: BLACK
- ▲ WIRE COLOR FOR 115/60/1 UNITS: WHITE
- ▲ WIRE COLOR FOR 208-230/60/1 UNITS: BLACK W/WHITE STRIPE

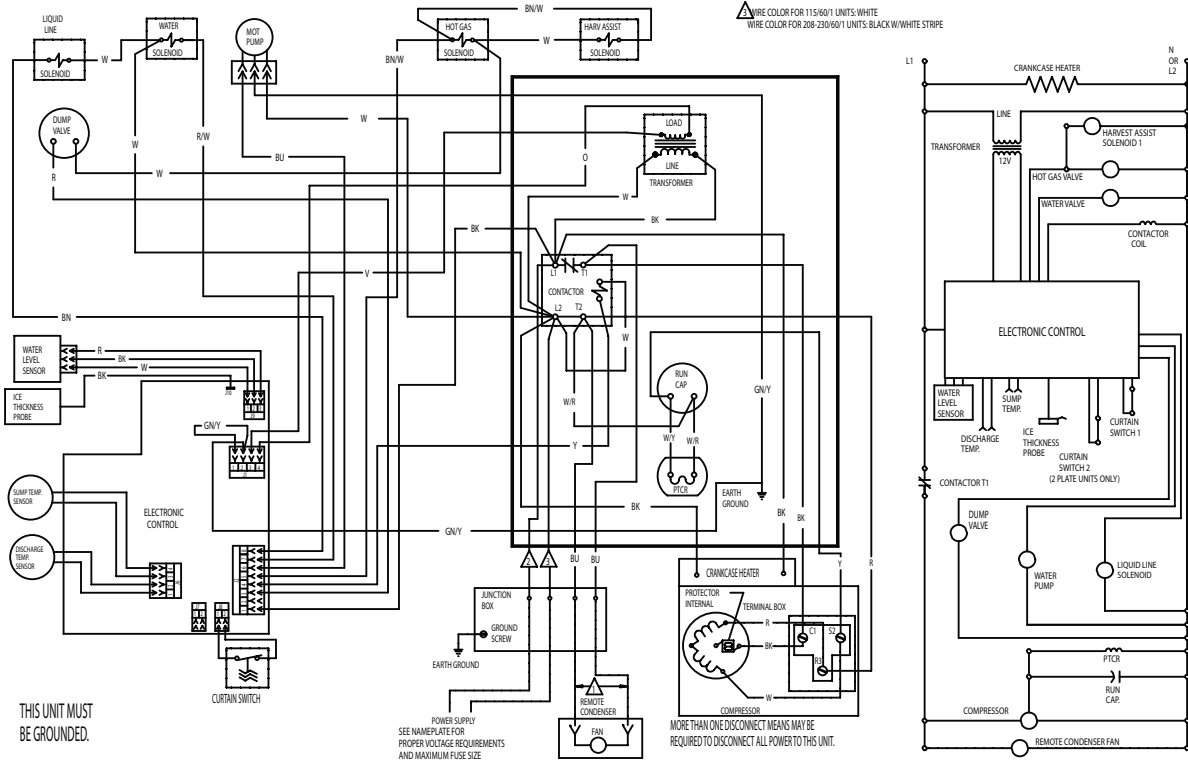

C0530R - C Series

17-3511-01

USE COPPER CONDUCTORS ONLY

- ▲ DASHED LINES INDICATE FIELD WIRING WHICH MUST BE INSTALLED IN ACCORDANCE WITH THE NATIONAL ELECTRICAL CODE AND ALL STATE AND LOCAL CODES.
- ▲ WIRE COLOR FOR 208-230/60/1 AND 115/60/1 UNITS: BLACK
- ▲ WIRE COLOR FOR 115/60/1 UNITS: WHITE
- ▲ WIRE COLOR FOR 208-230/60/1 UNITS: BLACK W/WHITE STRIPE

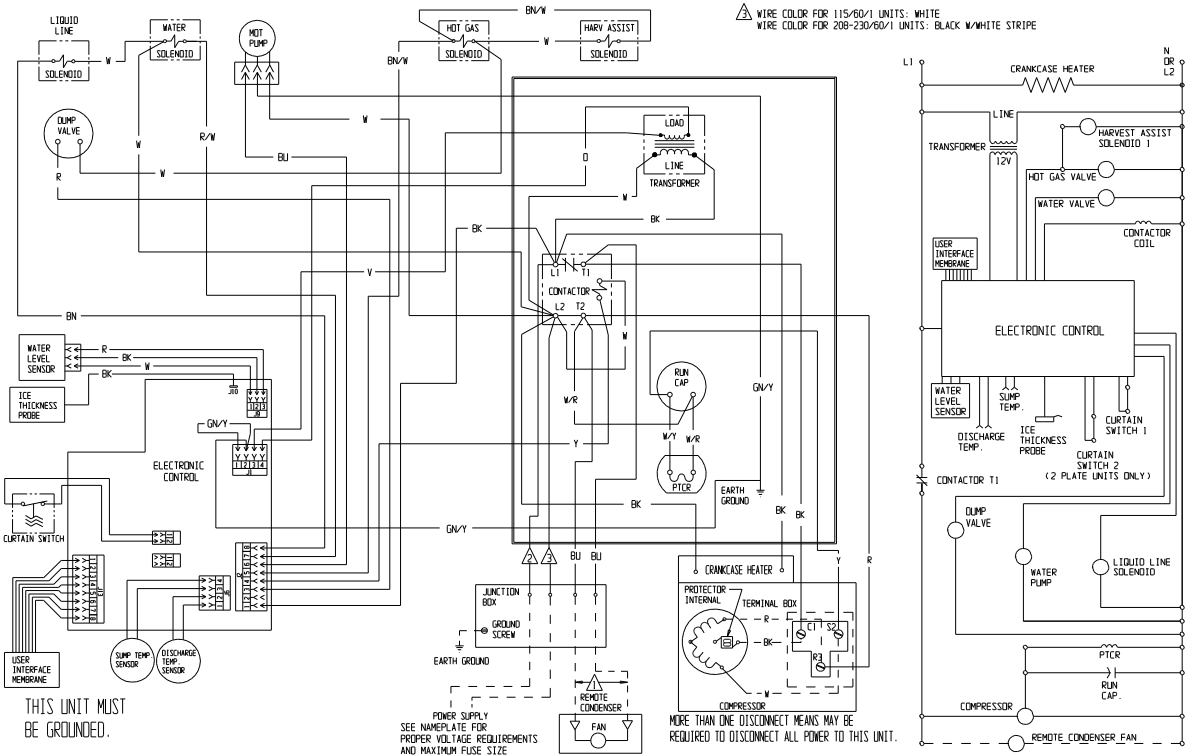

C0530R - D Series

Wiring Diagrams

17-3054-01

USE COPPER CONDUCTORS ONLY

⚠ DASHED LINES INDICATE FIELD WIRING WHICH MUST BE INSTALLED IN ACCORDANCE WITH THE NATIONAL ELECTRICAL CODE AND ALL STATE AND LOCAL CODES.

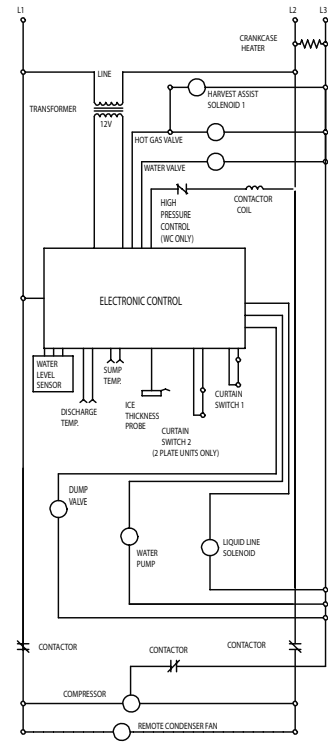
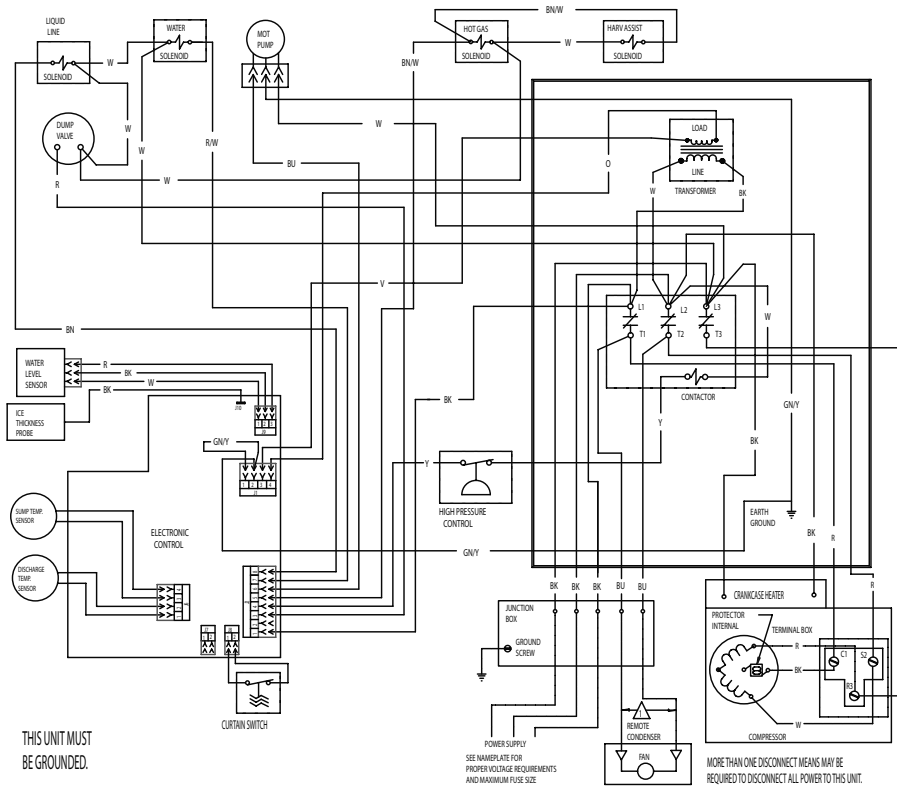

THIS UNIT MUST BE GROUNDING.

SEE NAMEPLATE FOR PROPER VOLTAGE REQUIREMENTS AND MAXIMUM FUSE SIZE.

MORE THAN ONE DISCONNECT MEANS MAY BE REQUIRED TO DISCONNECT ALL POWER TO THIS UNIT.

C0830R, C1030R Three Phase, A-B Series

17-3507-01

USE COPPER CONDUCTORS ONLY

⚠ DASHED LINES INDICATE FIELD WIRING WHICH MUST BE INSTALLED IN ACCORDANCE WITH THE NATIONAL ELECTRICAL CODE AND ALL STATE AND LOCAL CODES.

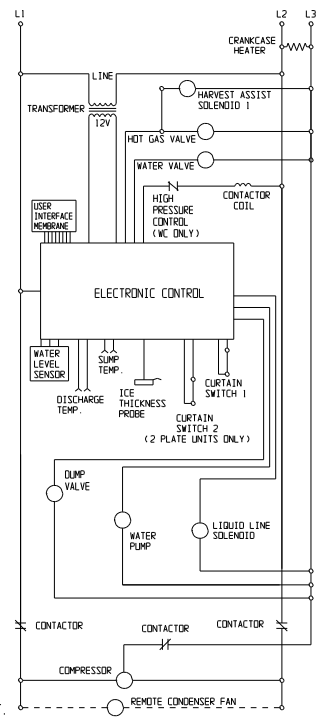
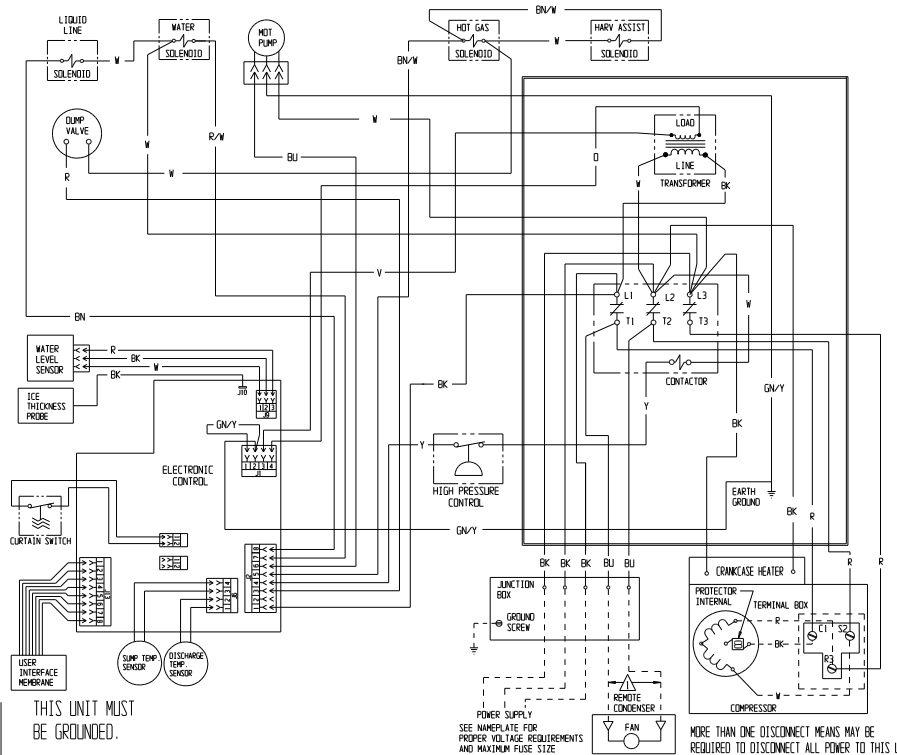

THIS UNIT MUST BE GROUNDING.

SEE NAMEPLATE FOR PROPER VOLTAGE REQUIREMENTS AND MAXIMUM FUSE SIZE.

MORE THAN ONE DISCONNECT MEANS MAY BE REQUIRED TO DISCONNECT ALL POWER TO THIS UNIT.

C0830R, C1030R Three Phase, D Series

Wiring Diagrams

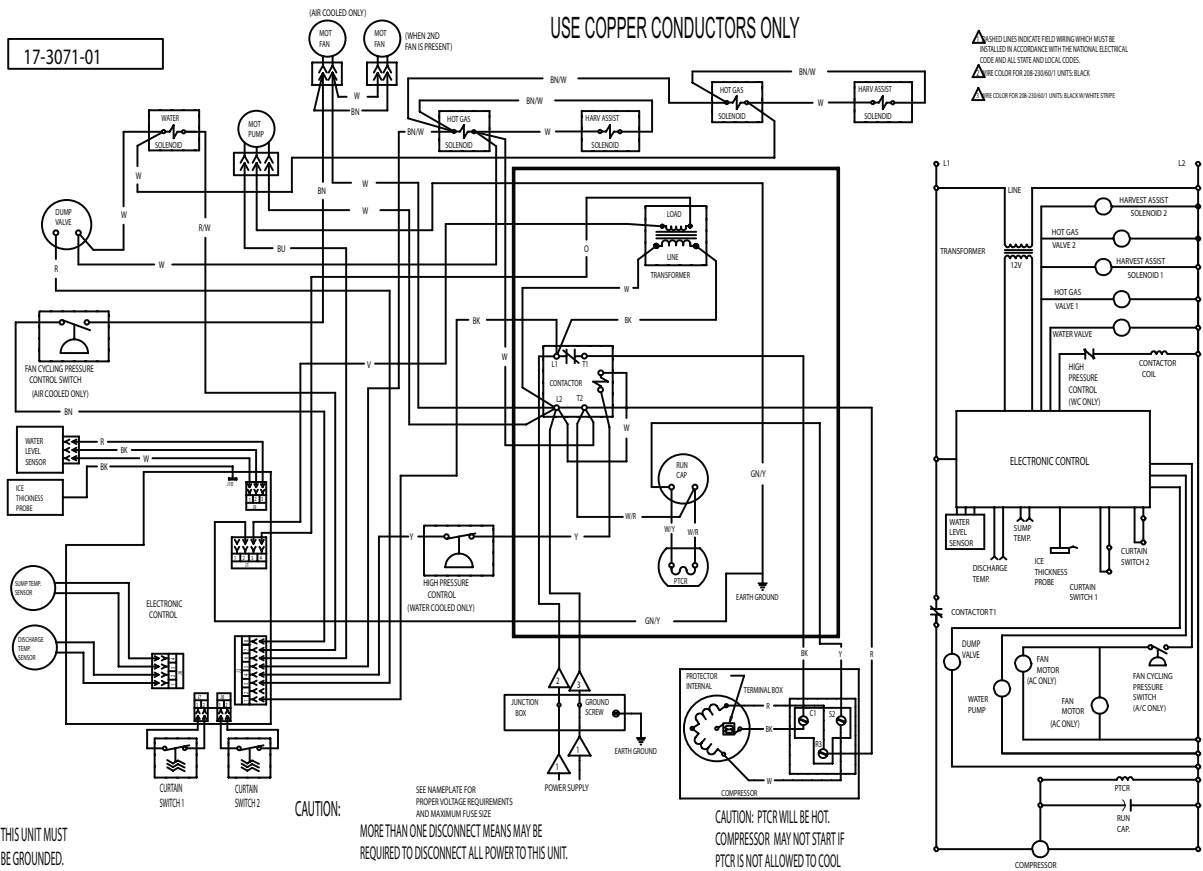

C1448, C1848, C2148 Single Phase, A-B Series

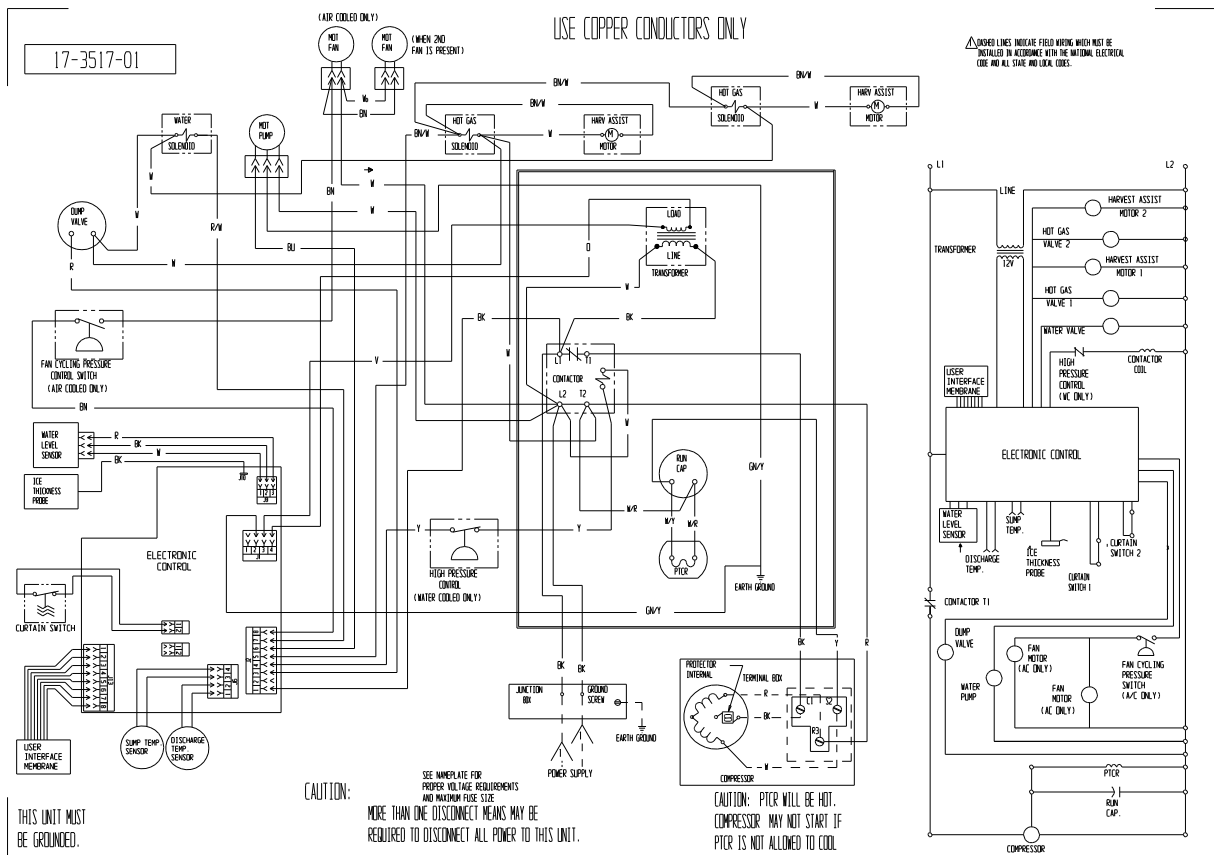

C1448, C1848 Single Phase, D Series

Wiring Diagrams

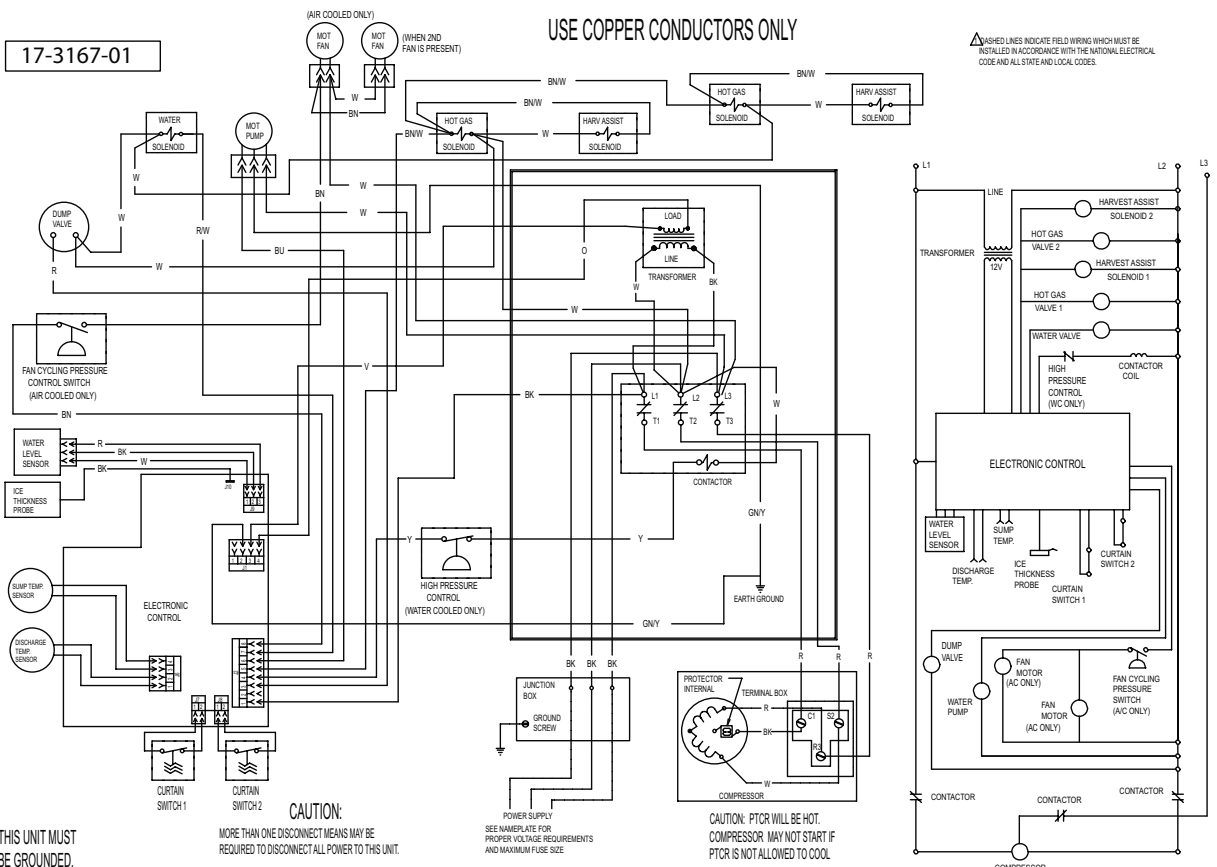

C1448, C1848, C2148 Three Phase, A-B Series

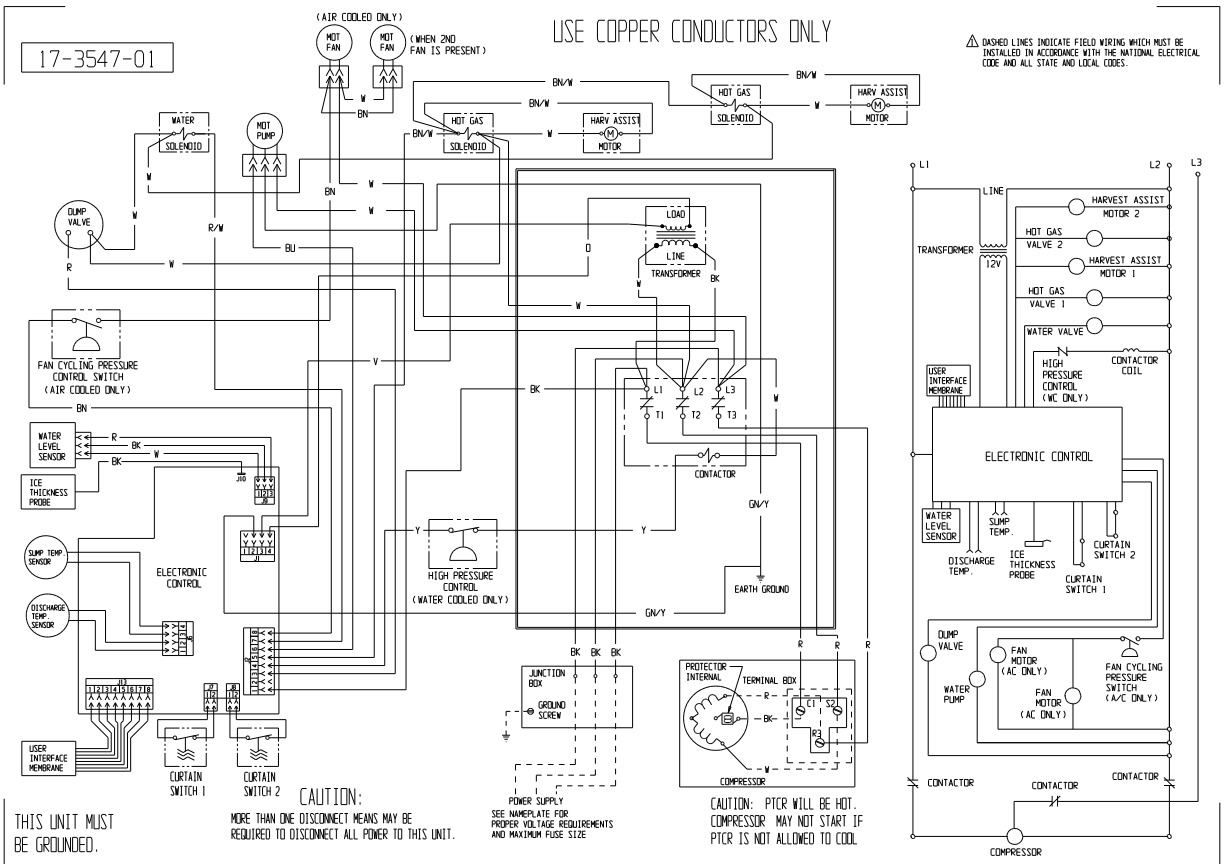

C1448 Three Phase, D Series

Wiring Diagrams

17-3074-01

USE COPPER CONDUCTORS ONLY

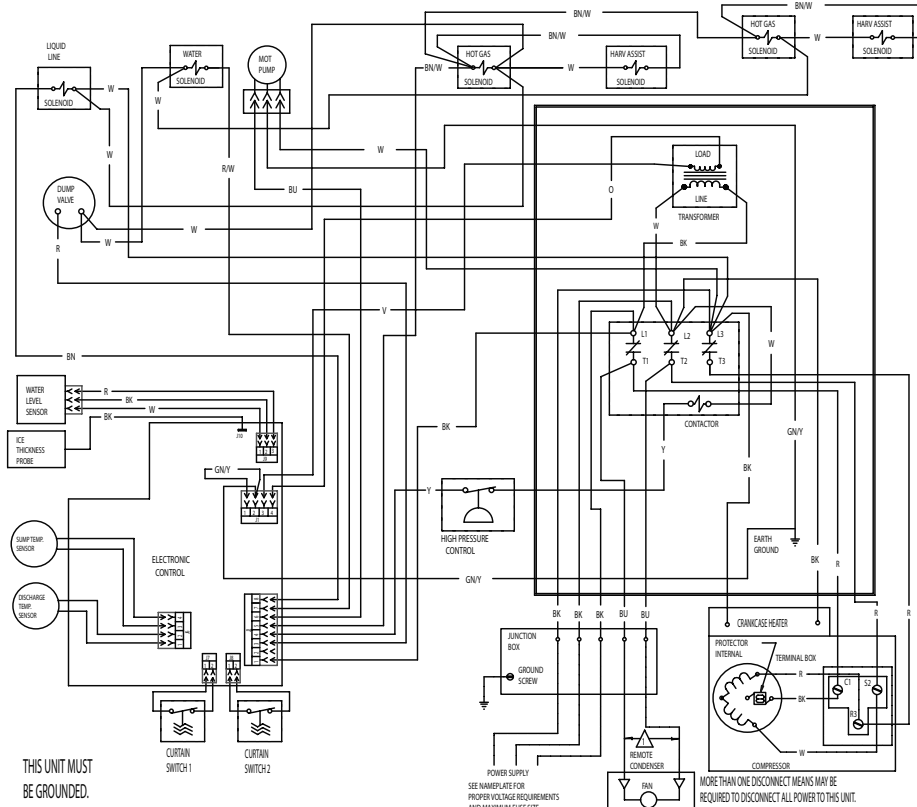

△ DASHED LINES INDICATE FIELD WIRING WHICH MUST BE INSTALLED IN ACCORDANCE WITH THE NATIONAL ELECTRICAL CODE AND ALL STATE AND LOCAL CODES.

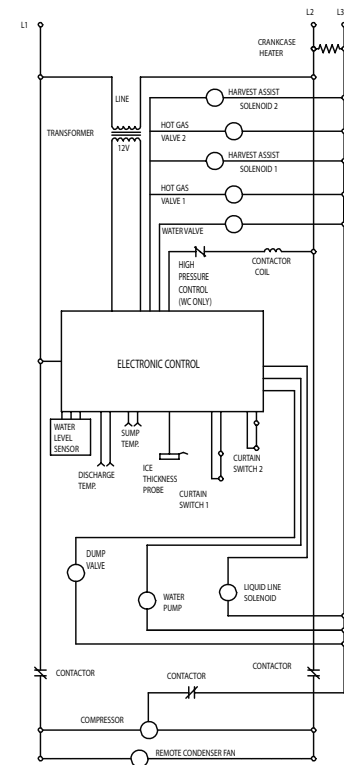

C1448R, C1848R, C2148R Three Phase, A - B Series

17-3546-01

USE COPPER CONDUCTORS ONLY

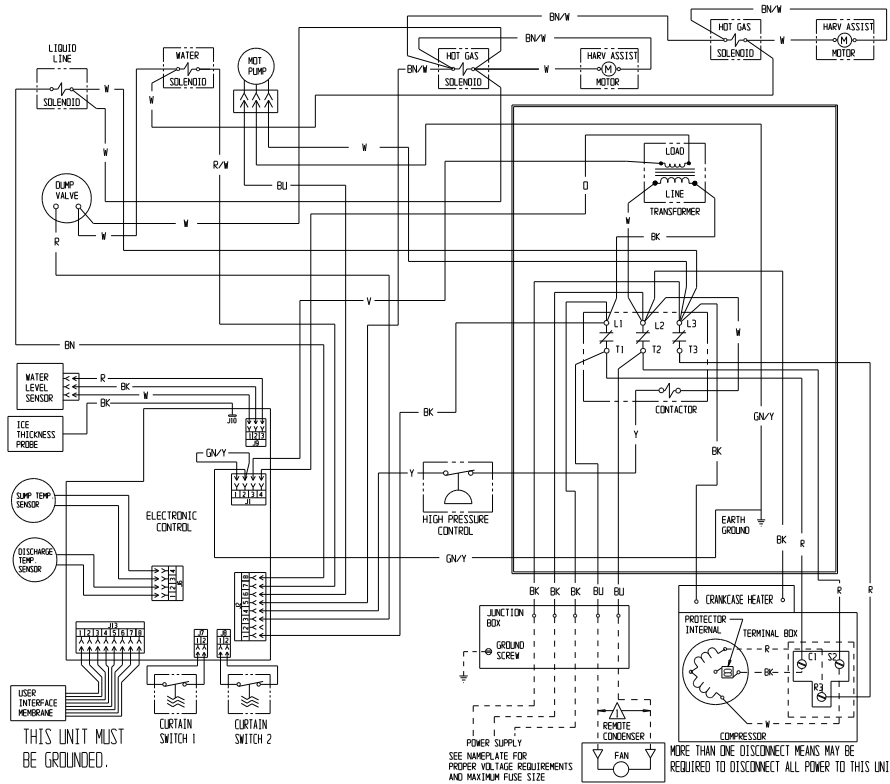

△ DASHED LINES INDICATE FIELD WIRING WHICH MUST BE INSTALLED IN ACCORDANCE WITH THE NATIONAL ELECTRICAL CODE AND ALL STATE AND LOCAL CODES.

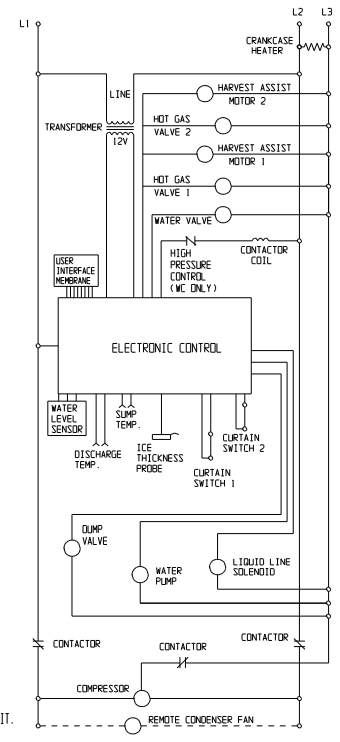

C1448R, C1848R, C2148R, Three Phase, D Series

Wiring Diagrams

17-3250-01

USE COPPER CONDUCTORS ONLY

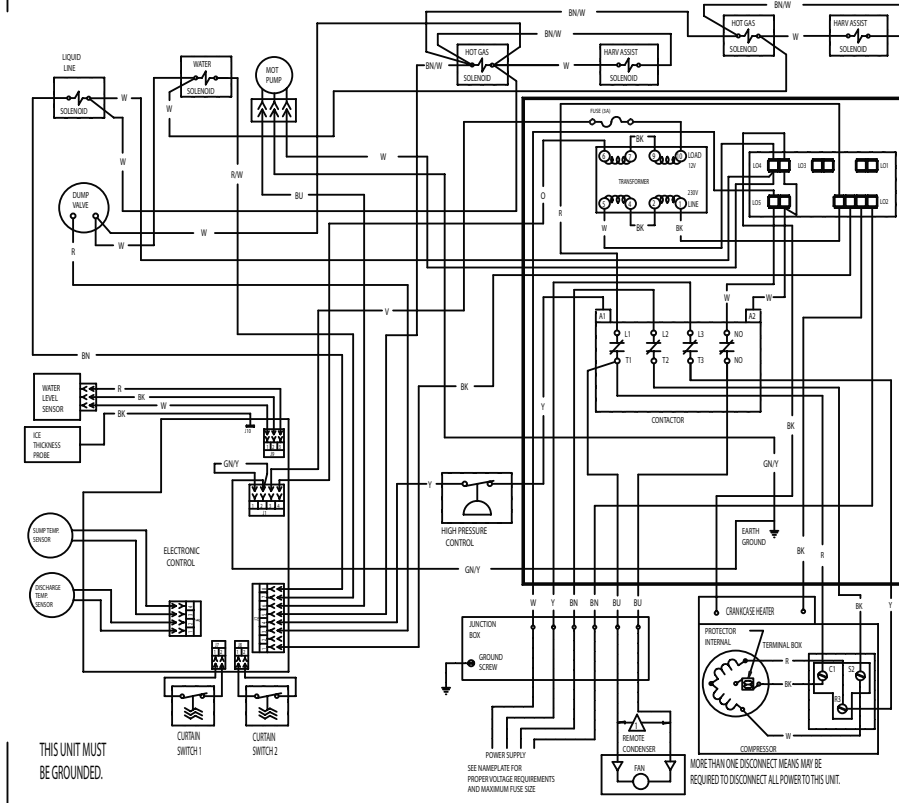

▲ WIPED LINES INDICATE FIELD WIRING WHICH MUST BE INSTALLED IN ACCORDANCE WITH THE NATIONAL ELECTRICAL CODE AND ALL STATE AND LOCAL CODES.

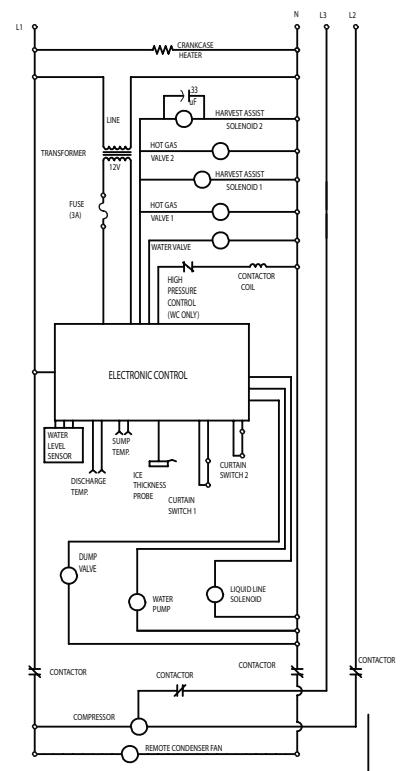

C1448R-63 230/380-420/50/3

17-3550-01

USE COPPER CONDUCTORS ONLY

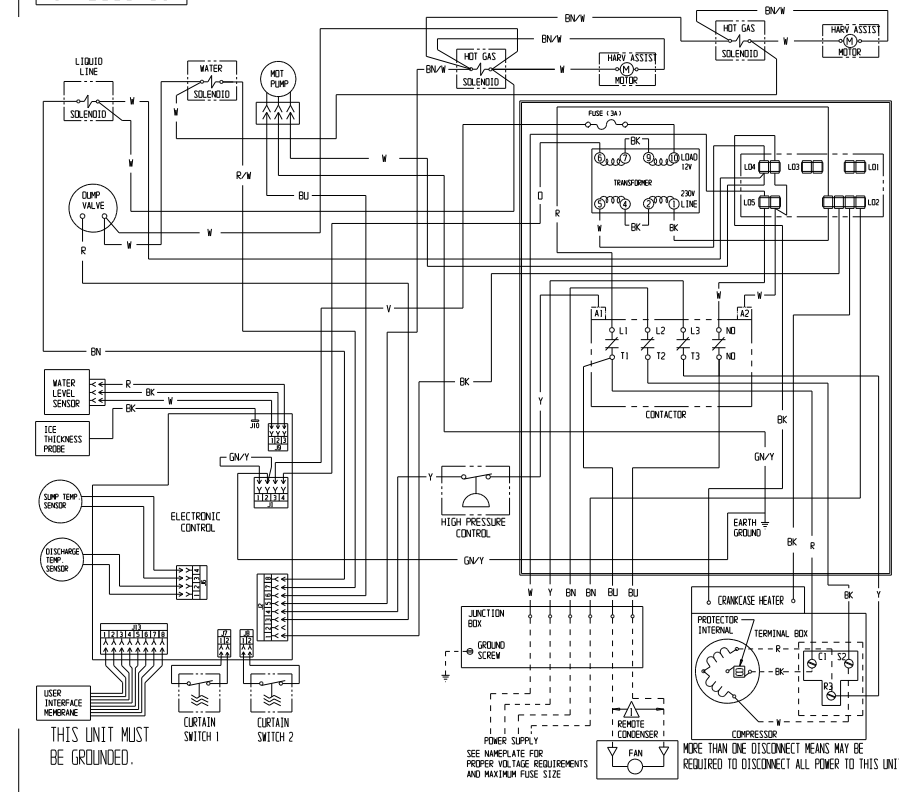

▲ DASHED LINES INDICATE FIELD WIRING WHICH MUST BE INSTALLED IN ACCORDANCE WITH THE NATIONAL ELECTRICAL CODE AND ALL STATE AND LOCAL CODES.

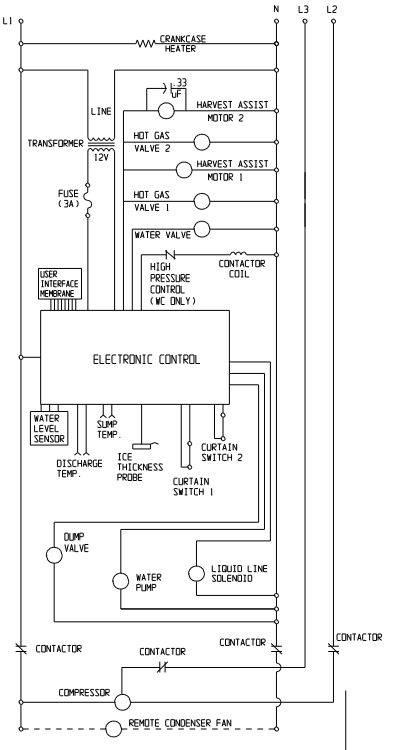

C1448R-63 230/380-420/50/3 D Series

Wiring Diagrams

17-3178-01

USE COPPER CONDUCTORS ONLY

△ DASHED LINES INDICATE FIELD WIRING WHICH MUST BE INSTALLED IN ACCORDANCE WITH THE NATIONAL ELECTRICAL CODE AND ALL STATE AND LOCAL CODES.

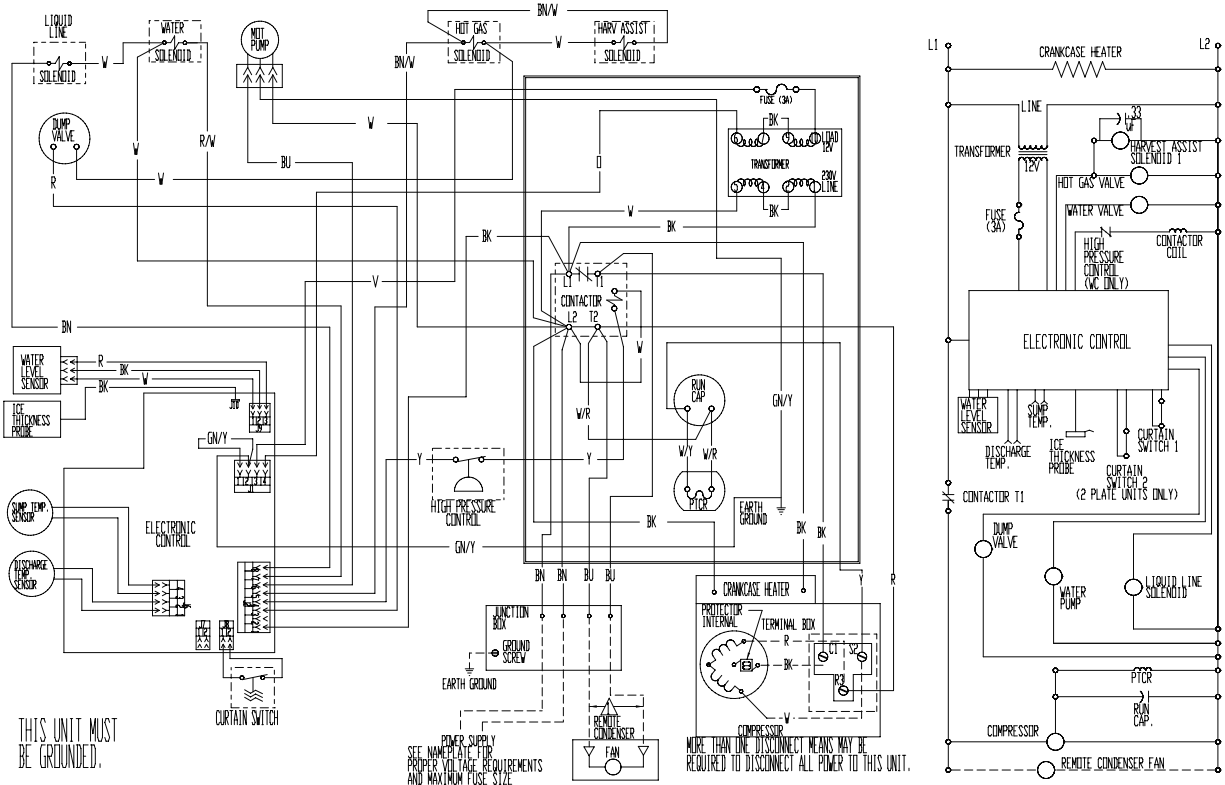

C0630R-6, C0830R-6, C1030R-6

17-3503-01

USE COPPER CONDUCTORS ONLY

△ DASHED LINES INDICATE FIELD WIRING WHICH MUST BE INSTALLED IN ACCORDANCE WITH THE NATIONAL ELECTRICAL CODE AND ALL STATE AND LOCAL CODES.

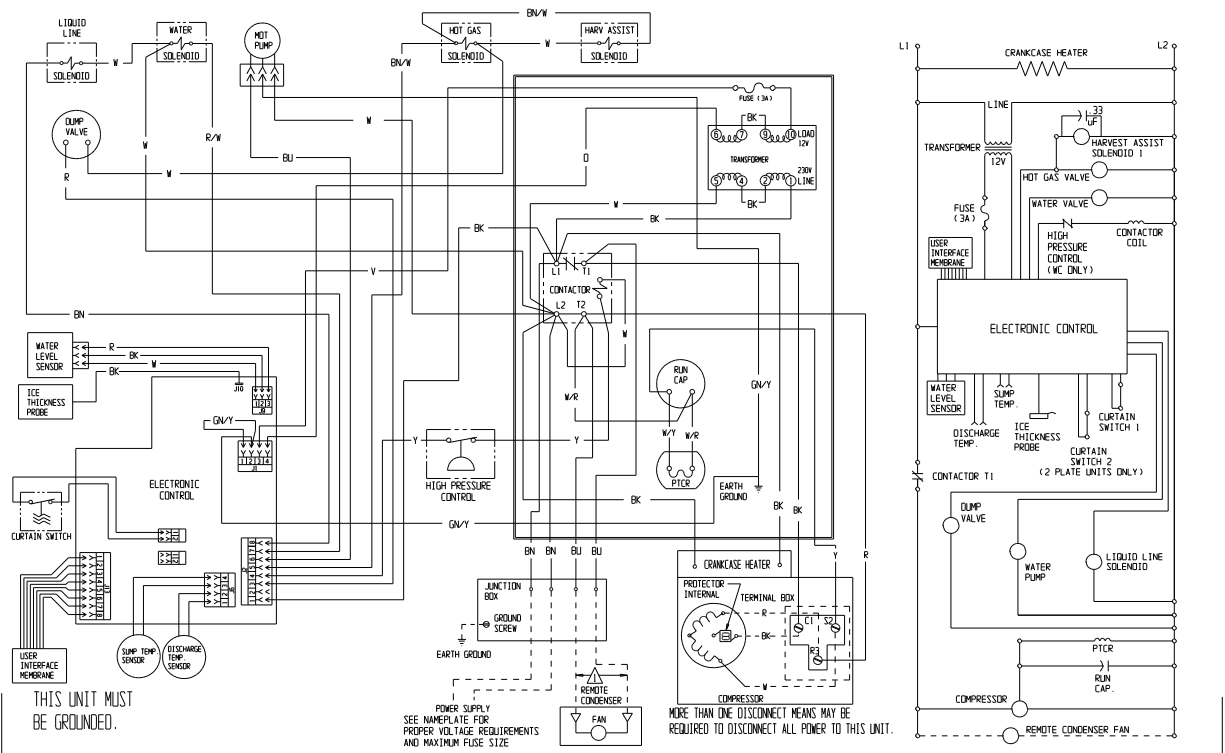

C0630R-6, C0830R-6, C1030R-6 D Series

Wiring Diagrams

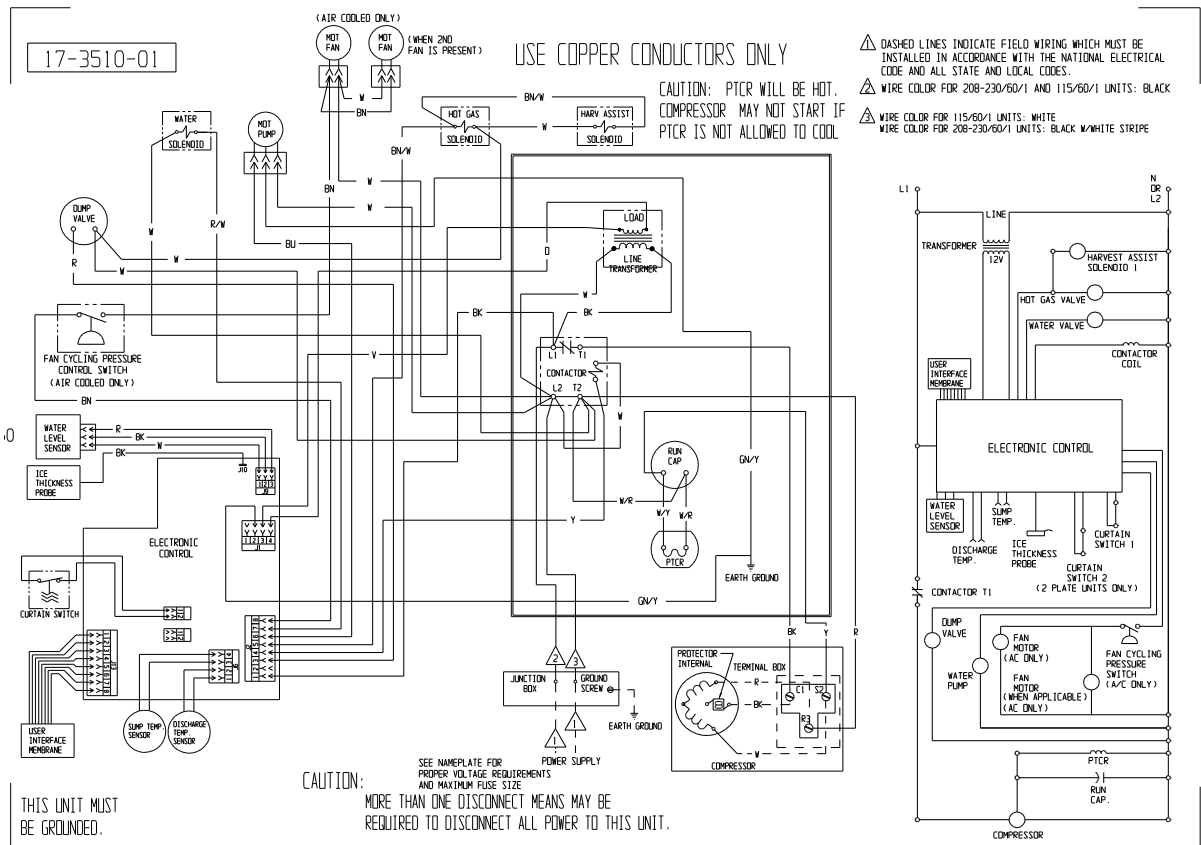
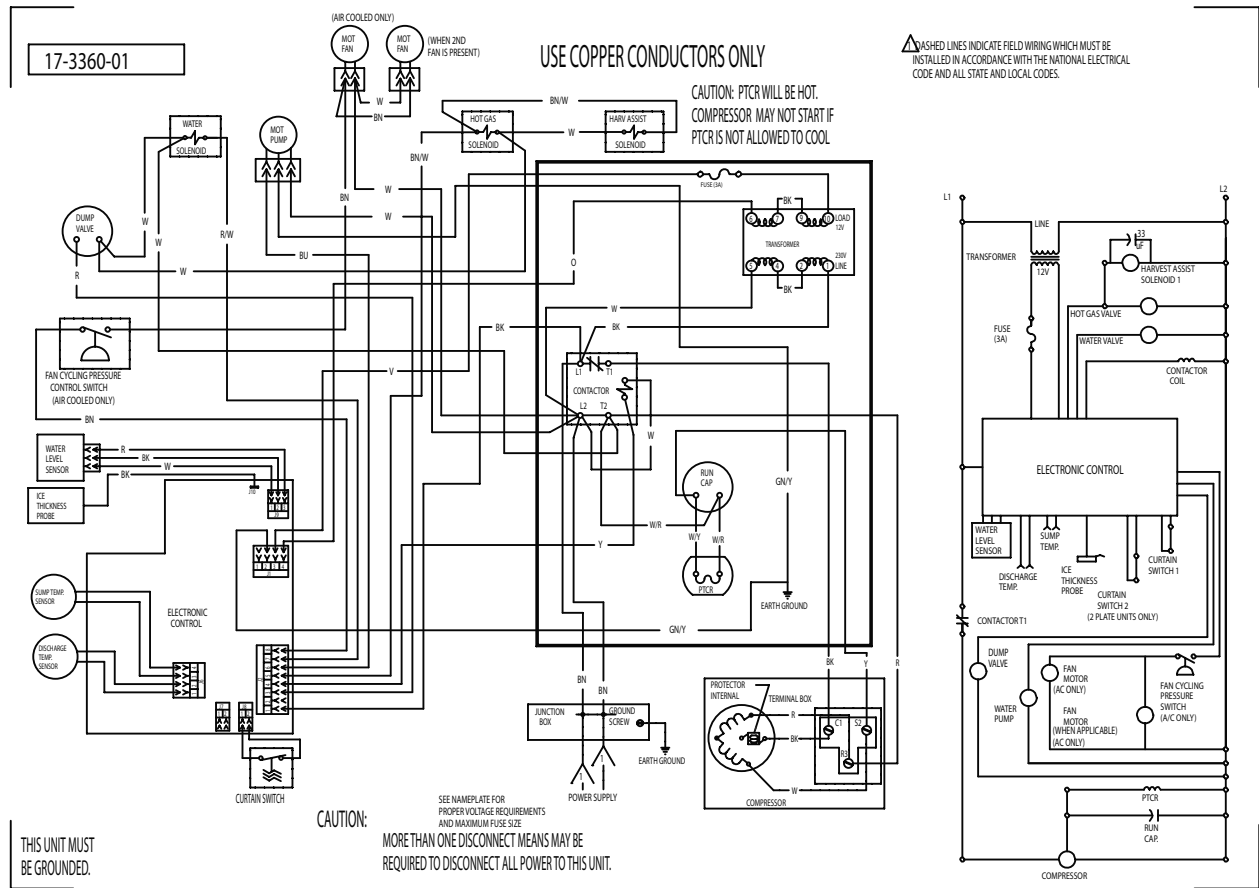

Repair Section

Inlet Water Solenoid Valve

1 Disconnect electrical power

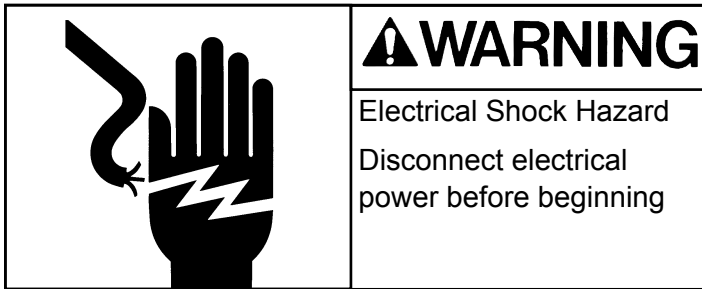

2 Shut off the water supply.

3 Remove front and left side panels.

4 Unplug wire from coil.

5 Disconnect water supply tube from the inlet of the valve.

6 Disconnect the water outlet tube.

7 Remove the two mounting screws holding the valve to the back panel.

8 Pull the valve forward and out of the machine.

Fan Blade or Motor

1 Push and release the Off button

2 Disconnect electrical power.

3 Remove front panel, sound shield and left side panel.

4 Unplug fan motor wire leads.

5 Remove fan motor mounting brackets from shroud. Note: Fastener size is 3/8" hex

6 Carefully remove fan motor and blade assembly from machine cabinet.

7 Loosen set screw, pull fan blade from motor shaft.

8 If the blade is the only part being changed, reverse to reassemble. Note: blade mounts purge to end of motor shaft.

9 If the motor will be changed, remove mounting brackets from fan motor. Note: Fastener size is 1/4" hex.

10 Reverse to reassemble.

Repair Section

Harvest Assist Solenoid / Mechanism

- 1 Remove front panel.
- 2 Push and release Manual Harvest button
- 3 Disconnect electrical supply

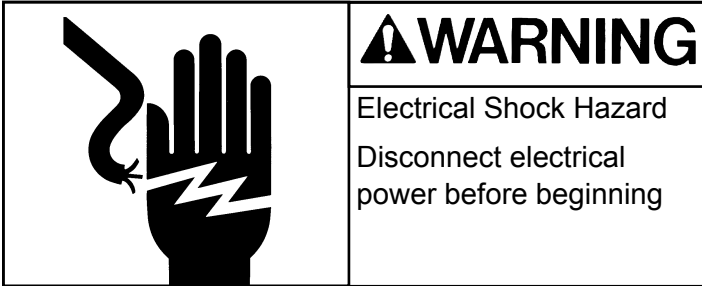

- 4 Remove sound shield (when used).
- 5 Unplug wires from solenoid or mechanism.
- 6 Remove screws and solenoid or mechanism from cabinet
- 7 Reverse to reassemble.

Note: Solenoid replaced by mechanism beginning in 2013. Solenoid prior to 2010 may be eligible for recall. See www.scotsman-ice.com for details

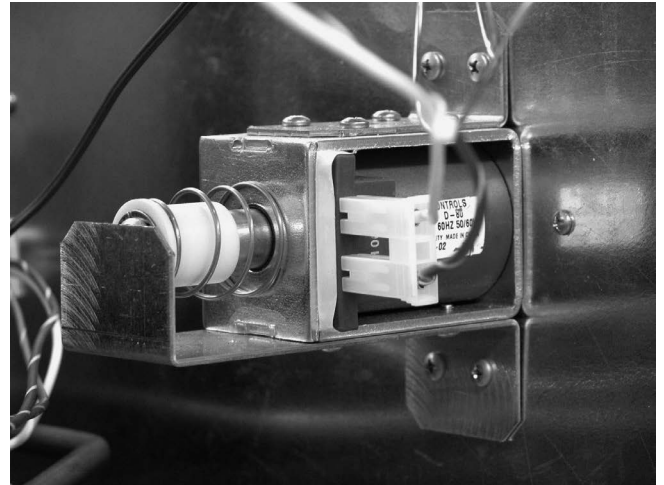

Original Harvest Assist Solenoid

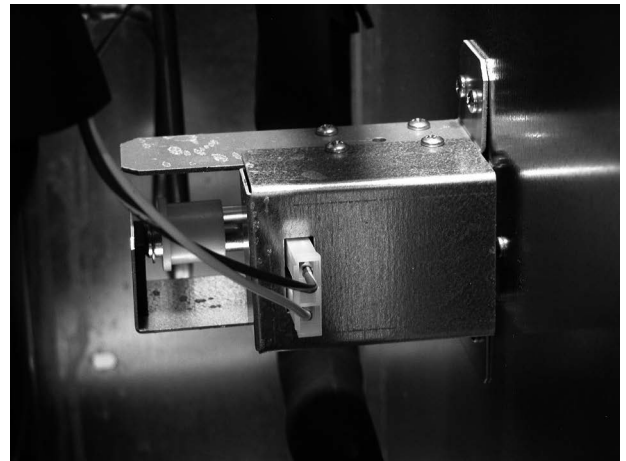

2010 and later Harvest Assist Solenoid



Harvest Assist Mechanism, use began 2013

Repair Section

Ice thickness sensor

1. Push and release the Off switch.
2. Remove front and top panels.
3. Push and release the Harvest switch
4. Remove the evaporator cover.
5. Remove the sound shield (when used).
6. Disconnect electrical power.

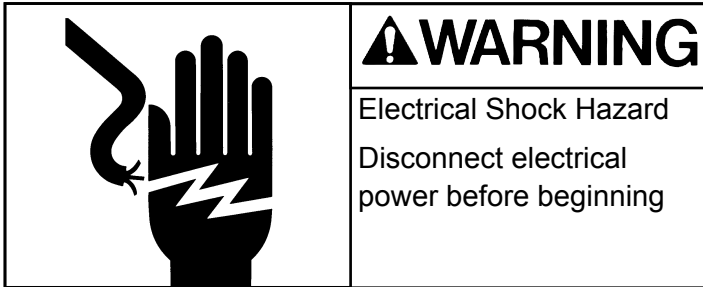

7. Open the control box.
8. Remove curtain.
9. Locate sensor, squeeze mounting legs together to release it from the mounting bracket.
10. Remove sensor, follow wire back to control box.
11. Disconnect from controller connection J10.
12. Remove sensor from machine.
13. Reverse to reassemble.
14. Set initial probe-to-evaporator-surface gap using a 7/32" drill bit as a gauge.

Repair Section

Capacitor (run)

1. Disconnect electrical power.
2. Remove front panel.
3. Open control box cover.
4. Remove right side of control box.
5. Remove metal barrier from control box
6. Remove screw holding strap to back of the control box.
7. Remove wires from capacitor
8. Connect wires to new capacitor, refer to wiring diagram as needed.
9. Reverse to reassemble.

Contactor

1. Disconnect electrical power.
2. Remove front panel.
3. Open control box cover.
4. Remove right side of control box.
5. Remove metal barrier from control box
6. Remove mounting screws holding contactor to control box.
7. Exchange wires from old controller to new. Refer to wiring diagram as needed.
8. Reverse to reassemble.

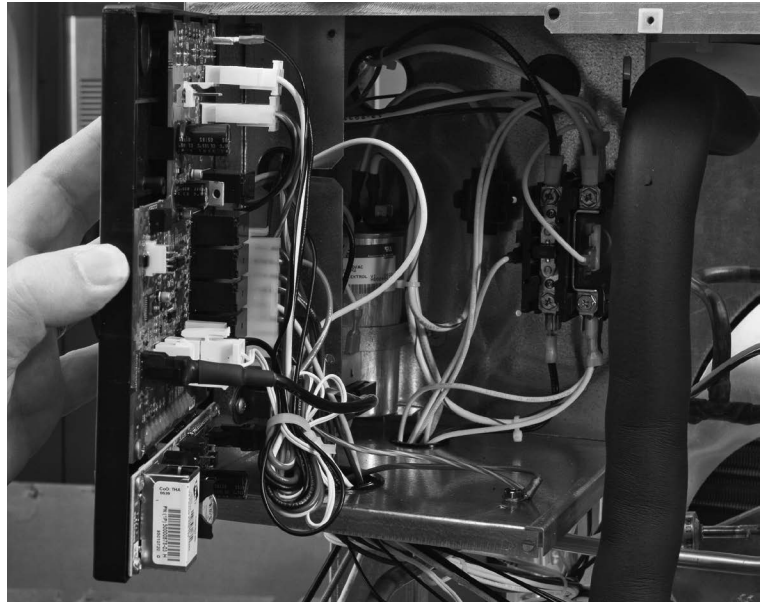

Repair Section

Controller

1. Disconnect electrical power.

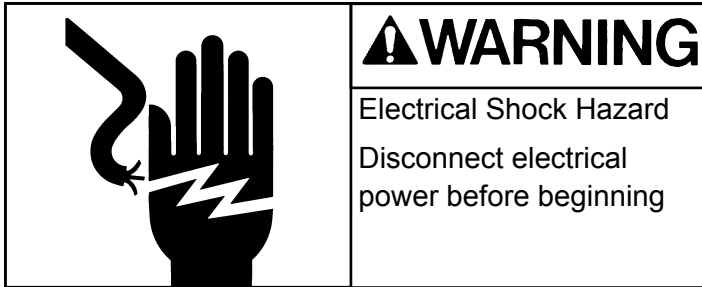

2. Remove front panel.
3. Open control box door.
4. Unplug all wires from controller.
5. Remove screws holding controller to door
6. Push controller snaps down and pull controller from mounting bracket.
7. Before touching new controller, discharge any static electricity by touching the metal surface of the ice machine cabinet.
8. Rotate selector switch to the proper model number for the machine the controller is being installed on.
9. Install new controller on mounting bracket, secure with original screws.
10. Attach all wires removed.
11. Shut control box cover.
12. Switch on the electrical power.

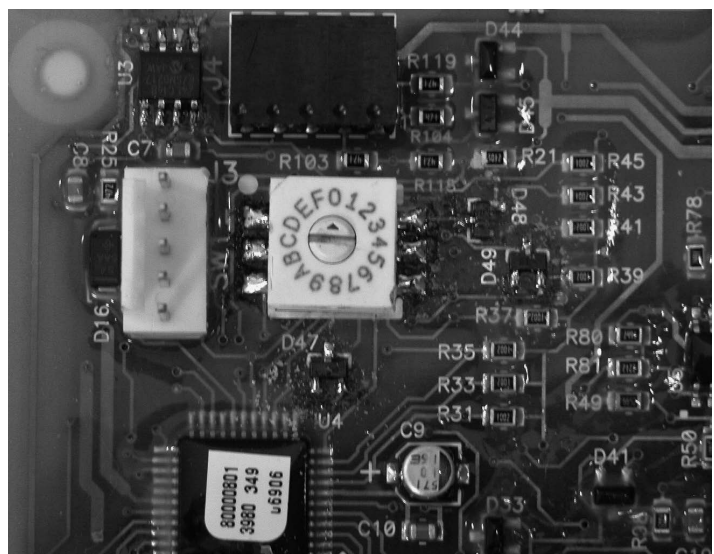
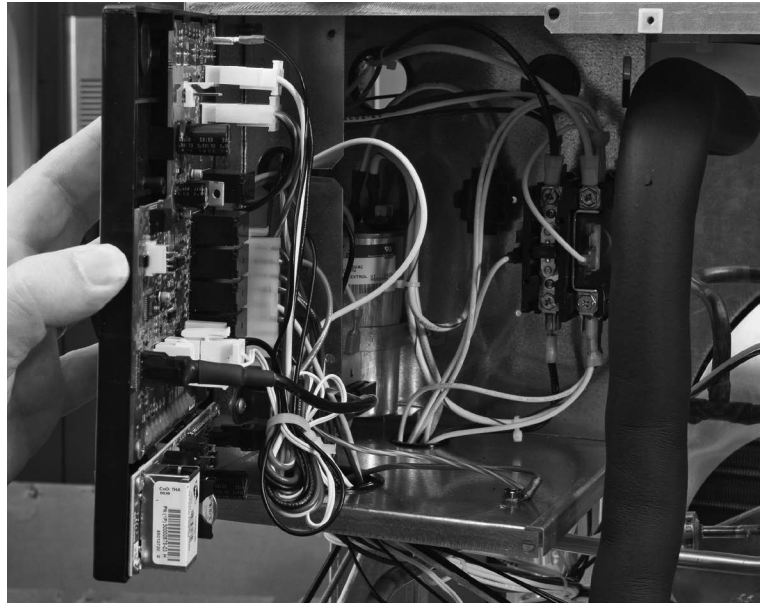

Controller's Model Selector Switch

Repair Section

Curtain

- Push and hold the Off button to shut the machine off.
- Remove front panel.
- Remove evaporator cover.
- Push inside tab in to release front curtain pin from holder.
- Pull curtain from machine.
- Reverse to reassemble.

Note: Two plate machines must place curtain on correct evaporator. Exception is the articulated curtain, which has magnets on both ends.

- Push and release the ON button to restart the machine.

Curtain switch

1. Push and hold the Off button to shut the machine off.
2. Disconnect electrical power

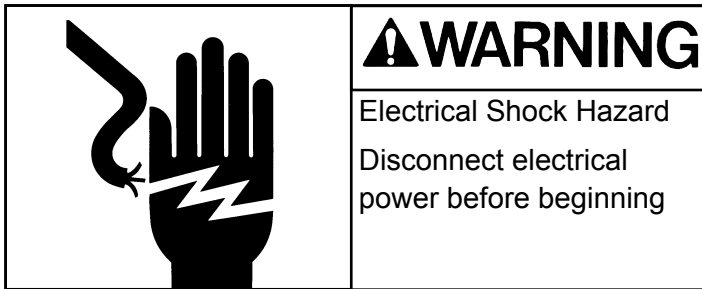

3. Remove front panel.
4. Remove evaporator cover.
5. Remove sound shield (when used)
6. Open control box.
7. Locate curtain switch on evaporator mounting bracket. Pull switch from its snaps or remove 2 screws.
8. Dismount wires from sump cover and remove from J7 or J8 connector on control board.
9. Reverse to reassemble. Be sure wires are re-mounted to sump cover edge.

Repair Section

Purge valve

1. Push and hold the Off button to shut the machine off.
2. Disconnect electrical power.

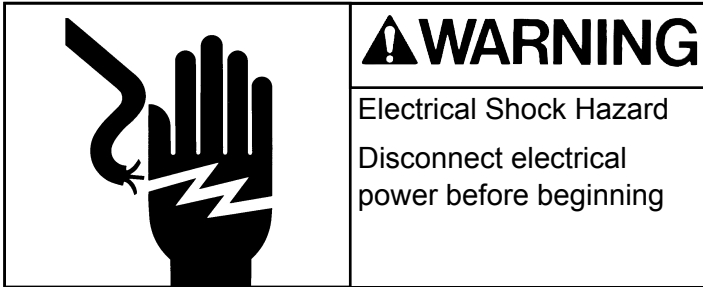

3. Remove front panel.
4. Remove left side panel.
5. Unplug wires from valve coil.

Note: The coil can be removed from the valve body by rotating it 1/8 turn CW. After removal of the coil the spring and plunger can be taken out.

6. Remove screws holding valve to mounting bracket.
7. Remove inlet and outlet hoses
8. Remove valve from cabinet.
9. Reverse to reassemble
10. Push and release the On button to restart the machine

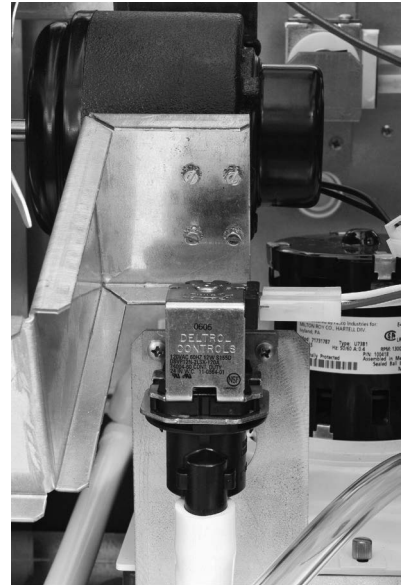

Water level sensor

1. Push and hold the Off button until the machine shuts off.
2. Remove the front panel.
3. Remove the sound shield.
4. Locate water level sensor.
5. Squeeze the locking tabs together and pull the sensor up and out of the sump.
6. Unplug the electrical connection from the sensor.
7. Reverse to reassemble

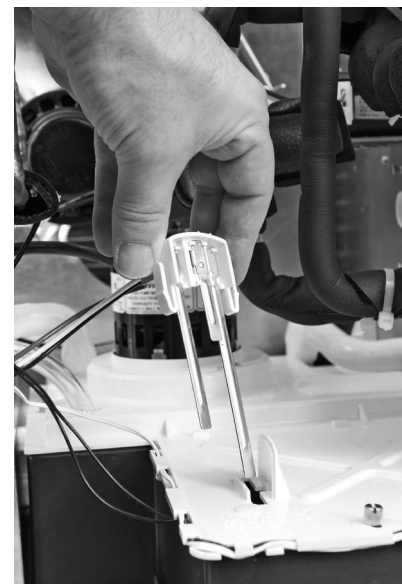

Repair Section

Water pump

1 Push and hold the Off button until the machine shuts off.

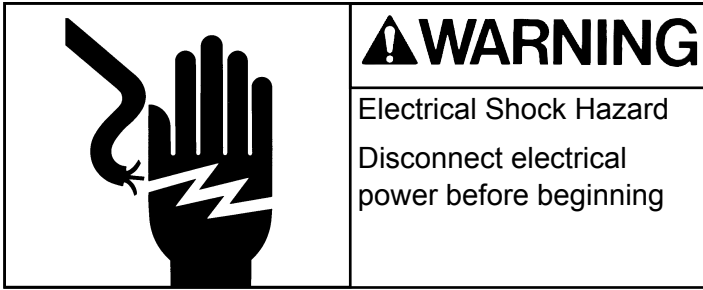

2 Remove the front panel.

3 Remove the sound shield.

4 Unplug the water pump

5 Rotate the pump CCW about 1/8 turn to release it.

6 Lift pump up and remove hose

7 Attach hose to new pump

8 Install in pump bracket.

9 Rotate CW about 1/8 turn to lock it in place.

10 Plug pump into harness

11 Return panels to their original positions and secure with the original screws.

12 Push and release the ON button to restart the machine.



Refrigeration Removal and Replacement

Evaporator

1. Remove panels as needed for evaporator access.
2. Remove evaporator cover.
3. If the machine was in operation, push and release the Harvest button to warm up the evaporator.
4. Disconnect electrical power.

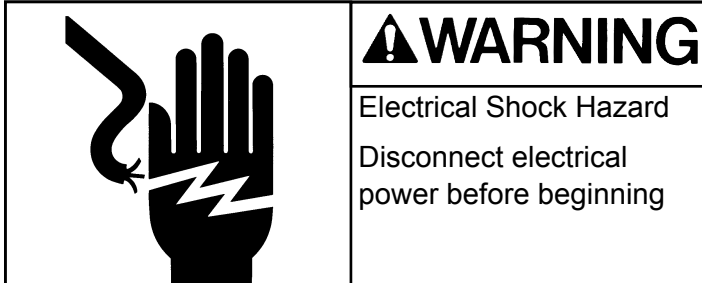

5. Remove harvest assist
6. Recover refrigerant.
7. Remove curtain
8. Remove water distributor
9. Release ice thickness sensor
10. Remove water distributor bracket from the top of the evaporator
11. Connect nitrogen bottle to discharge access port. Open both access valves.
12. Open nitrogen valve
13. Unsweat the inlet and outlet refrigerant tubes. Use caution when heating the tubing, do not damage the freezing compartment walls.
14. Shut nitrogen valve.
15. Gain access to the right side of the unit. Remove mounting screws holding the evaporator to the freezing compartment wall. Note: fastener size is 5/16" hex.
16. Remove the evaporator from the ice machine.
17. Attach new evaporator to freezing compartment wall, but do not secure tightly at this time.
18. Install the harvest assist. Be sure pin moves freely thru ejection hole.
19. Open nitrogen valve
20. Reconnect inlet and outlet tubes by brazing the copper tubes together.
21. Replace filter drier.
22. Shut access valves, remove nitrogen bottle.
23. Evacuate to at least 300 microns.
24. Weigh in the nameplate charge. Check for leaks.
25. Return ice thickness sensor bracket, ice thickness sensor, water distributor, curtain and evaporator cover to their original positions.
26. Reconnect electrical power.
27. Return panels to their original positions.

Refrigeration Removal and Replacement

Compressor

1. Remove front panel and sound shield (when used).
2. If the machine was in operation, push and release the Harvest button to shut it down. Wait until the harvest cycle has ended so the evaporator has no ice on it.
3. Open the replacement compressor box. Check the compressor nameplate, be SURE that the replacement compressor is the correct one for the unit.
4. Disconnect electrical power.

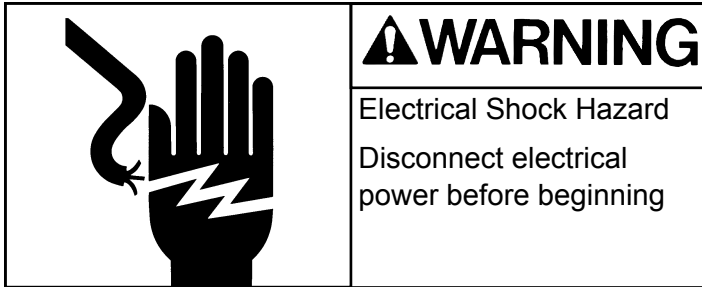

5. Recover refrigerant.
6. Remove compressor terminal cover and disconnect electrical leads.
7. Remove all the mounting bolts.
8. Open both discharge and suction access valves
9. Connect nitrogen to discharge access valve.
10. Open nitrogen valve.
11. Unsweat the suction, discharge and process tubes.
12. Unsweat the drier from the liquid line. Remove it.
13. Shut the nitrogen valve.
14. Remove the compressor from the ice machine. Note: Some models may require the control box to be moved slightly to allow compressor replacement.
15. Immediately place new compressor in ice machine.
16. Open nitrogen bottle and braze compressor suction, discharge and process joints together. Braze new drier into system.
17. Shut off nitrogen, shut access valves.
18. Evacuate to at least 300 microns.
19. Replace PTCR and run capacitor.
20. Weigh in the nameplate charge. Check for leaks.
21. Reconnect electrical leads.
22. Attach compressor terminal cover.
23. Reconnect electrical power.
24. Return sound shield and front panel to their original positions.

Note: If the compressor is being returned for warranty, braze the stubs shut and tag the compressor with the required information.

Refrigeration Removal and Replacement

Thermostatic Expansion Valve

1. Remove front panel.
2. Remove sound shield (when used)
3. If the machine was in operation, push and release the Harvest button to shut it down. Wait until the harvest cycle has ended so the evaporator has no ice on it.
4. Disconnect electrical power.

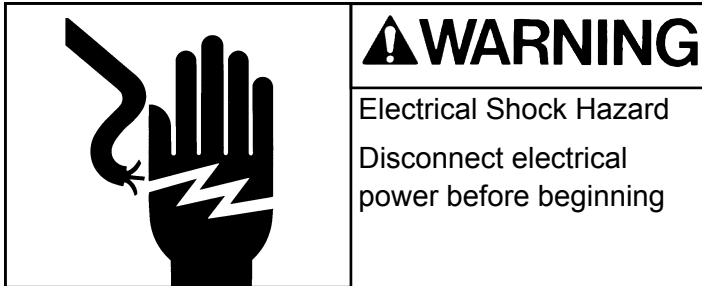

5. Recover refrigerant.
6. Remove insulation covering expansion valve and bulb.
7. Remove strap securing bulb to suction line.
8. Open both discharge and suction access valves
9. Unsweat the expansion valve from the liquid line. Remove it.
10. Unsweat the drier from the liquid line. Remove it.
11. Connect nitrogen to discharge access valve.
12. Immediately place new valve in ice machine.
13. Open nitrogen bottle and braze expansion valve inlet and outlet joints together. Braze new drier into system.
14. Shut off nitrogen, shut access valves.
15. Evacuate to at least 300 microns.
16. Weigh in the nameplate charge. Check for leaks.
17. Attach bulb to suction line. Position at 4 or 8 o'clock on the tube. Secure tightly but do not crush the bulb with the strap.
18. Attach valve and bulb insulation.
19. Reconnect electrical power.
20. Return sound shield and front panel to their original positions.

Optional add-on control information - KVS

Vari-Smart™ or KVS Adjustable ice level option

The adjustable ice level control is an optional add-on system consisting of an control board, label and sensor. The control board fits above the standard control and connects to it using connector J4. The sensor mounts to the base of the ice machine through a hole in the base.

The control has an adjustment knob. Rotating the knob CW lowers the maximum ice level that the ice machine will maintain in the bin or dispenser. When the ice level is at or above maximum for the setting, the bin full light on the ultrasonic board will be ON.

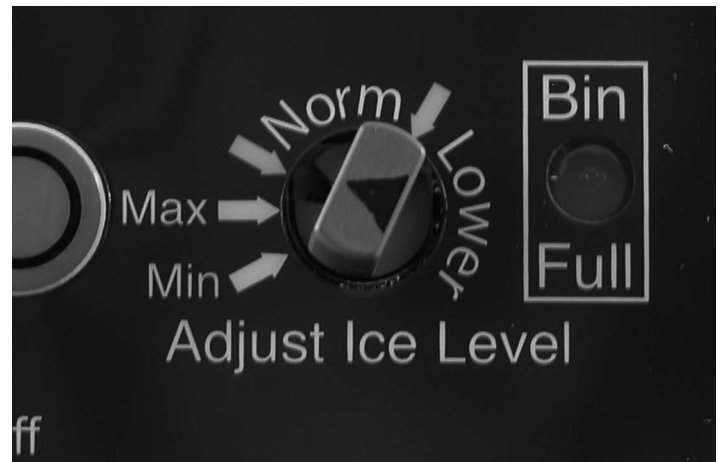
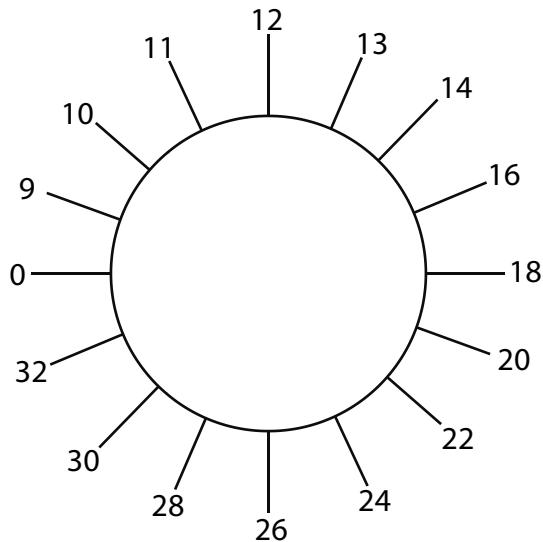

Vari-Smart Check Out

If the machine's sump water is below 40 degrees or so, the Vari-Smart will only signal Bin Full at the end of a harvest cycle. If above 40, it should do so at the beginning of freeze. The easiest way to check it is as follows:

1. Install the Vari Smart on the Prodigy.
2. Set the Vari-Smart on 32" (Min in photo above).
3. Connect power to the unit.
4. Put the unit into a Manual Harvest
5. Position something about 12" from the sensor. The object should be a solid, flat item like a panel or manual.
6. Cycle the curtain switch to terminate harvest (open and close the curtain – both on a two plate model).
7. The unit should shut off on bin full at the end of the harvest cycle. The Bin Full light will be on and a b will show in the code display of the controller.
8. Rotate the selector to the correct position and restart the ice machine.

Note: If a Smart-Board is on the machine, and it is controlling the Vari-Smart, rotating the Vari-Smart's knob will have no affect. The Smart-Board's control will have to be disengaged to perform this check out.

SCOTSMAN ICE SYSTEMS

775 Corporate Woods Parkway

Vernon Hills, IL 60061

USA

847-215-4500

800-726-8762

www.scotsman-ice.com