

CME1202 & CME1402 SERVICE PARTS

This parts lists shows the service parts for the CME1402, CME1202 air cooled and the CME1402, CME1202 water cooled.

Check the model number of the machine to be certain of obtaining the correct part.

Note: These machines are built in various electrical configurations, including single phase, 3 phase and 50 Hz. Double check all electrical components to be sure of obtaining the correct part.

Included at the back of the parts list are the wiring diagrams.

Table of Contents

Cabinet	Page 2
Refrigeration System	Page 3
Air and Water Cooled Parts	Page 4
Water System	Page 5
Control Box	Page 6
BH900 Bin	Page 7
Wiring Diagrams	Page 8

CME1202 & CME1402 SERVICE PARTS

CABINET PARTS

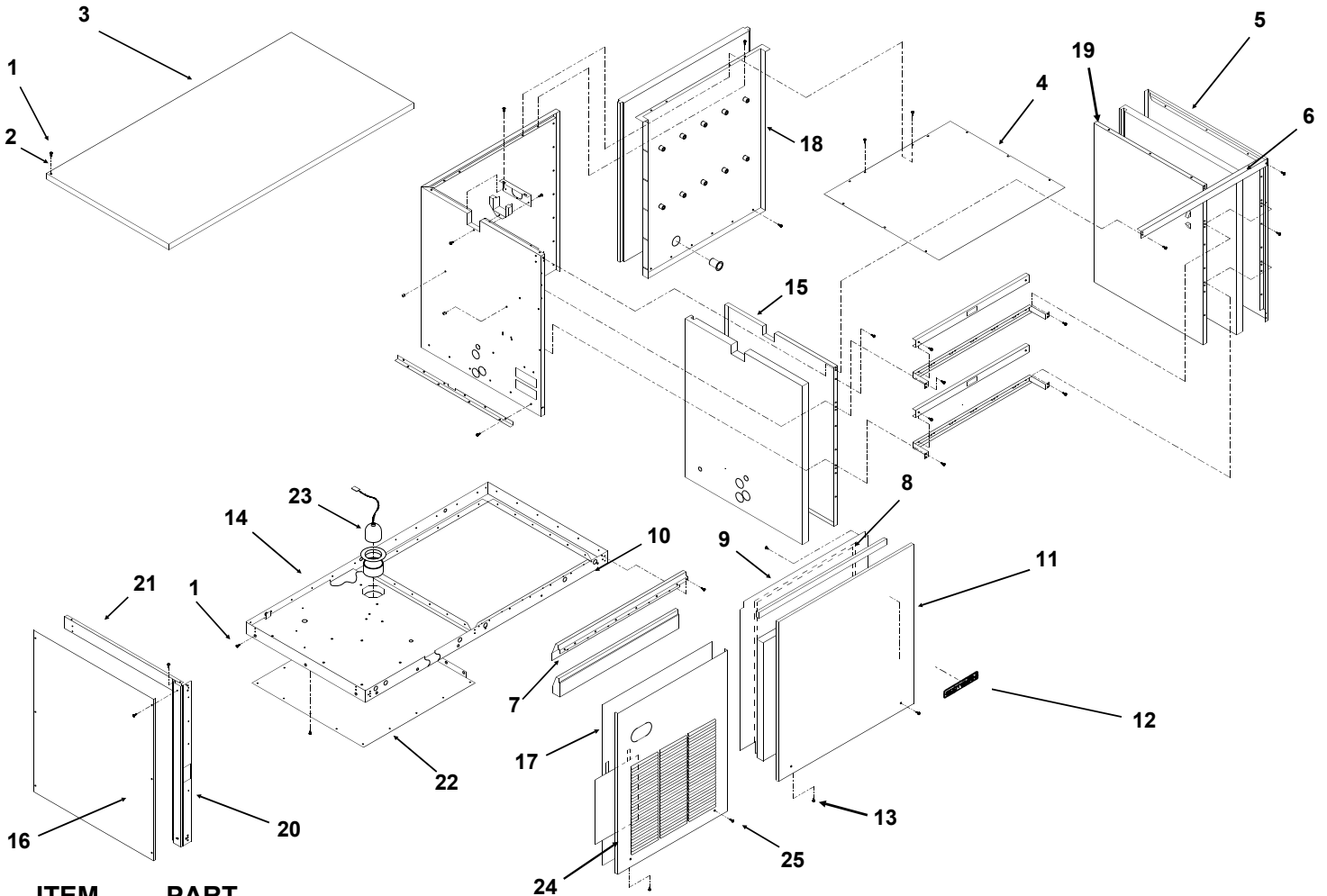

ITEM NUMBER	PART NUMBER	DESCRIPTION	ITEM NUMBER	PART NUMBER	DESCRIPTION
1	03-1531-01	Screws	13	03-1678-04	Thumb screw
2	03-1417-27	Washers		03-1678-03	Screw retainer
3	A35074-001	Panel top (sandalwood)	14	A35110-001	Base assembly
	A35074-015	Top panel, gray	15	02-2533-01	Liner, left side
	A35074-002	Panel top (stainless)	16	A35075-001	Left side panel, sandalwood
4	A33364-001	Liner top		A35075-015	Left side panel, gray
5	A29164-003	Right panel (sandalwood)		A35075-002	Left side panel, stainless
	A29164-015	Right panel, gray	17	02-3164-01	Air filter
	A29164-002	Right panel (stainless)	18	02-2531-01	Liner back
6	A30330-001	Brace front	19	02-2534-01	Right side liner
7	02-2532-01	Liner cap	20	A35069-001	Corner post
8	13-0595-00	Gasket (order per foot)	21	A35066-001	Brace
9	02-2795-01	Liner, front panel	22	02-3151-01	Plastic cover
10	03-1678-01	Speed clip	23	A34908-021	Transducer
11	A35401-022	Right front panel, stainless	24	A35400-001	Left frnt pnl, sandalwood
	A35401-021	Right front panel, sandalwood		A35400-015	Left front panel, gray
	A35401-024	Right front panel, gray		A35400-002	Left frnt pnl, stainless
	Front panels include insulation and liner.		25	03-1678-02	Panel screw
12	02-3252-01	Plastic bumper		03-1678-03	Screw retainer
	15-0711-01	Emblem for sandalwood		02-3252-01	Plastic bumper
	15-0808-03	Grey emblem for SS or gray			

CME1202 & CME1402 SERVICE PARTS

REFRIGERATION SYSTEM

ITEM NUMBER	PART NUMBER	DESCRIPTION	ITEM NUMBER	PART NUMBER	DESCRIPTION
1	16-0888-01	Defrost manifold assembly	8	18-2200-28	Grommet
2	16-0887-01	Evaporator suction assembly	9	03-1405-20	Screw
3	A30296-020	Evaporator plate		03-1407-07	Washer
4	16-0883-20	Accumulator		18-2200-27	Sleeve
4a	no number	1/2" armafex insulation	10	11-0495-21	Hot gas valve
5	11-0479-21	Fan control	11	16-0885-01	Distributor and tubes
6	11-0485-22	Hi press cut out, Air Cooled	12	12-2300-07	Hi temp cut out
	11-0486-21	Hi press. cut out, Water cooled	13	16-0882-21	TXV for all but 50 Hz
7		Compressors*		16-0882-21	TXV for 1202 50 Hz
18-8750-22	CME1202	60 Hz, single phase	14	02-3396-01	Insulation
18-8750-24	CME1202	60 Hz, 3 phase	15	16-0832-20	Access valve
18-8751-23	CME1402	60 Hz, single phase		16-0832-02	Stem cap
18-8751-25	CME1402	60 Hz, 3 phase		16-0832-03	Core or port cap
18-8750-27	CME1202	50 Hz, single phase		13-0617-51	O-ring

* Replacement compressors include a crankcase heater, not used on this model. It may be used or disconnected when installed. They also include a dryer

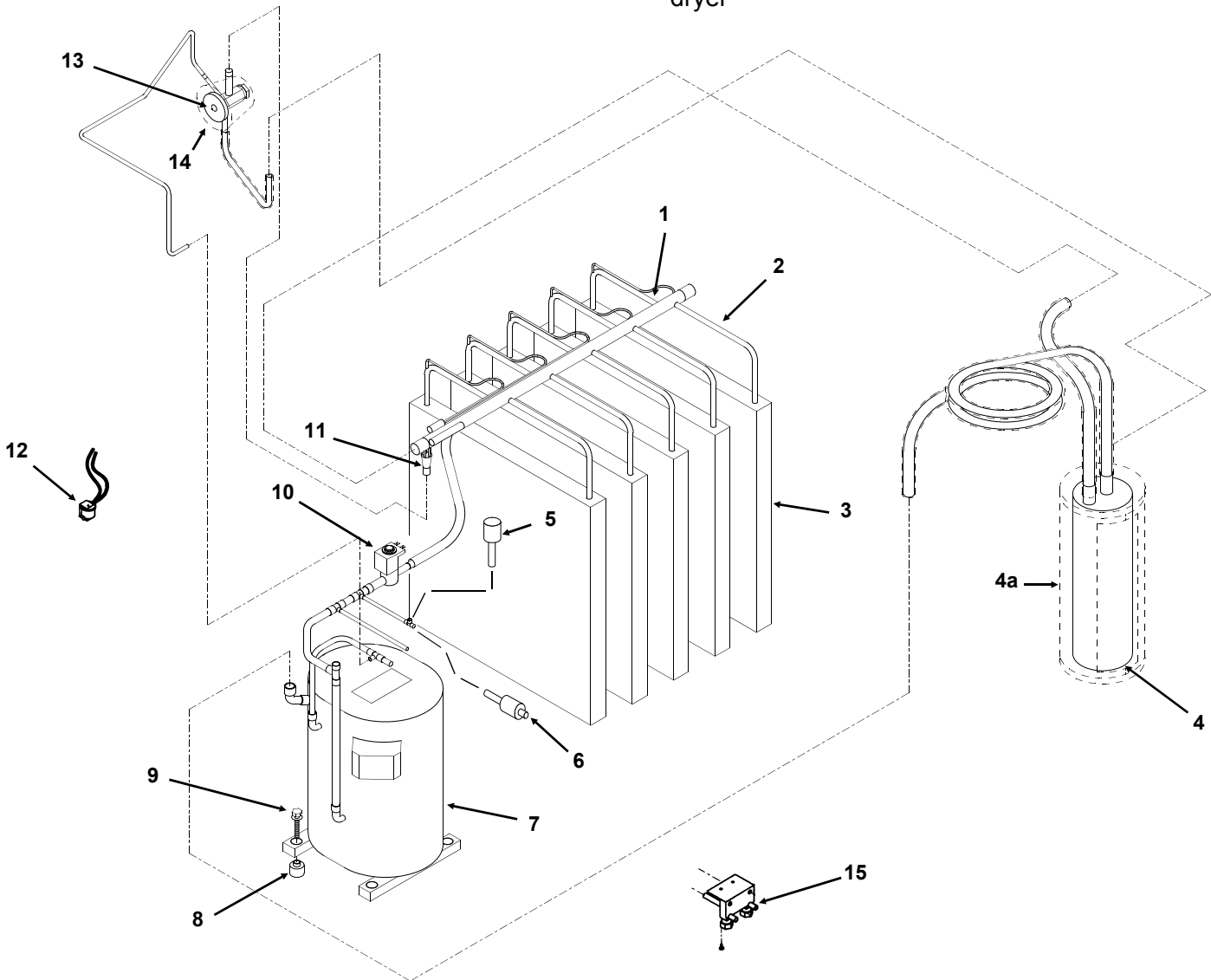

CME1202 & CME1402 SERVICE PARTS

CONDENSING ASSEMBLIES

AIR COOLED MODELS

ITEM NUMBER	PART NUMBER	DESCRIPTION
1	A36227-001	Fan shroud
2	18-8765-01	Fan blade
3	03-1251-01	Hex bolt
4	18-8764-01	Fan motor
5	A36397-001	Fan bracket
6	03-1406-10	Hex nut
7	02-3319-02	Dryer
8	18-8754-01	Condenser
9	A35069-001	Corner post

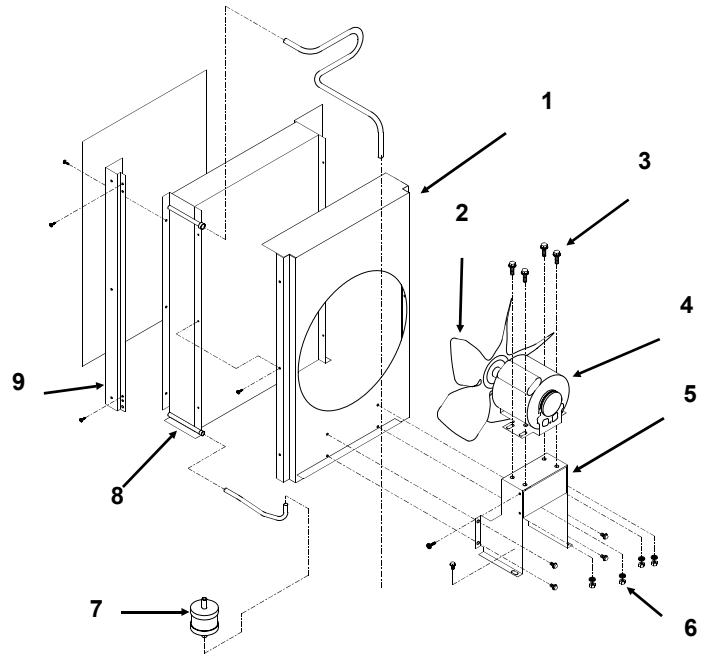

WATER COOLED MODELS

ITEM NUMBER	PART NUMBER	DESCRIPTION
1	11-0478-01	Water Regulator Valve
2	18-8767-25	Condenser, Water Cooled
3	03-1407-05	Washer
4	03-0571-01	Screw
5	A36206-001	Left back panel
6	02-2628-02	Receiver
7	A31828-001	Drain casting

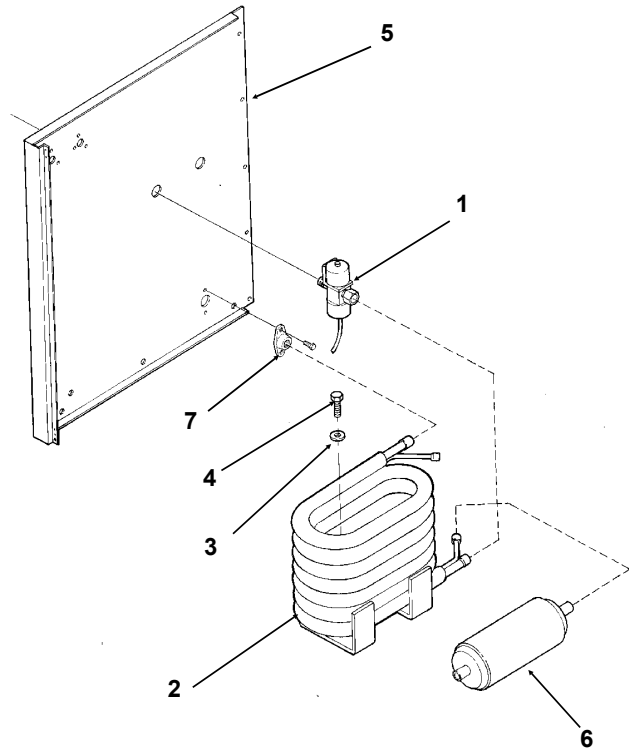

CME1202 & CME1402 SERVICE PARTS

WATER SYSTEM

ITEM NUMBER	PART NUMBER	DESCRIPTION
1	02-2521-01	Long water manifold
2	02-2519-01	Tee
3	A29703-001	Short water manifold
4	02-2527-01	Water dist. tube
5	02-1358-01	Clamp
6	A29730-001	Water Tube Assy
7	A30761-020	Sump Assembly
8	02-2814-10	Clamp
9	02-2814-12	Clamp
10	A30666-001	Pump Bracket
11	03-0571-01	Screw

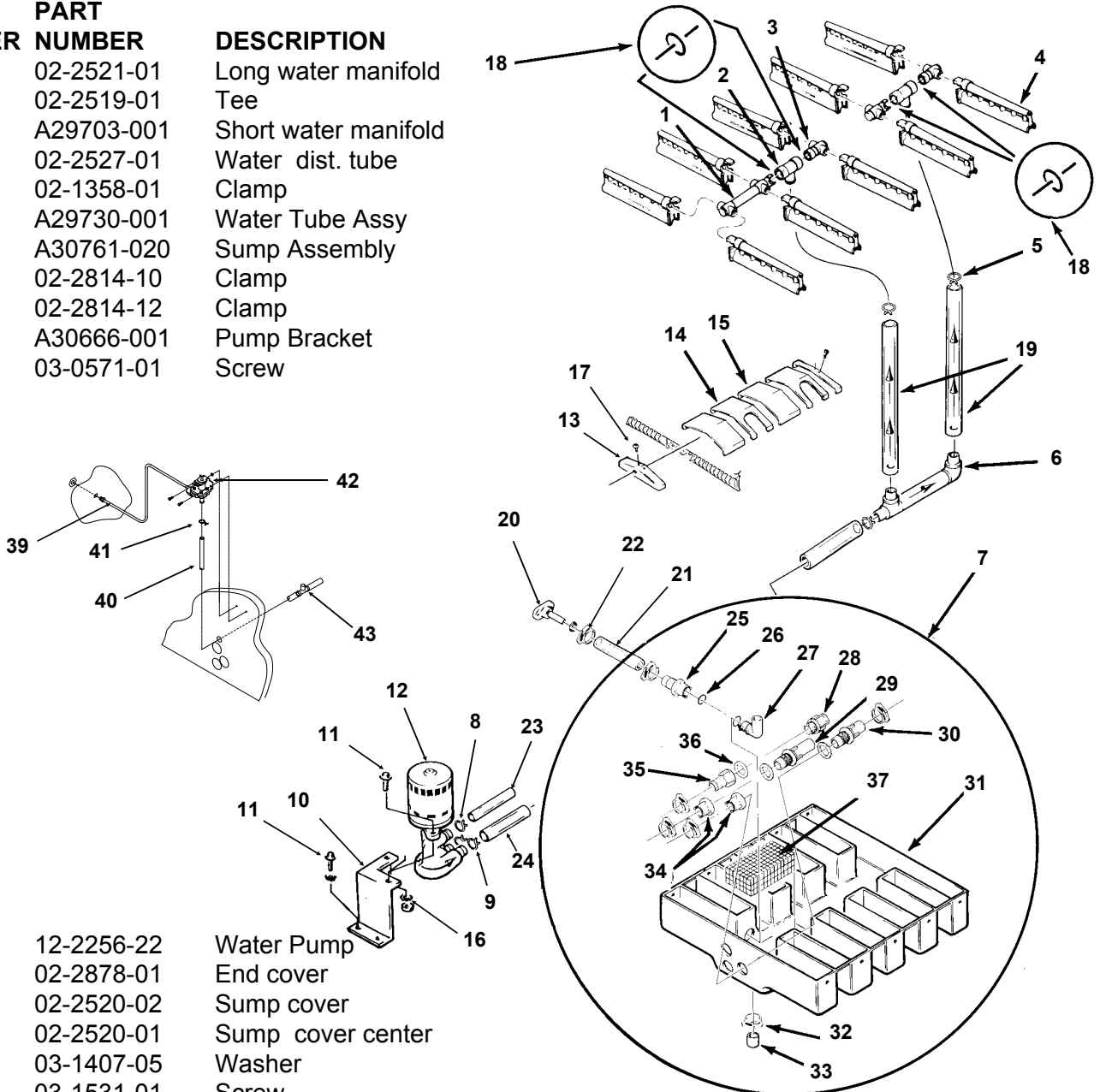

12	12-2256-22	Water Pump
13	02-2878-01	End cover
14	02-2520-02	Sump cover
15	02-2520-01	Sump cover center
16	03-1407-05	Washer
17	03-1531-01	Screw
18	13-0617-48	O-ring
19	13-0674-07	Hose (18.5")
20	A31757-002	Drain
21	13-0674-07	Tube, drain (7")
22	02-1358-01	Hose clamp
23	13-0674-07	Tube, need 6.25"
24	13-0674-08	Tube, need 6.6"
25	02-2606-01	Female tube
26	13-0617-02	O-ring
27	02-2125-01	Elbow
28	02-2080-01	Overflow
29	02-2792-01	Pick Up tube

30	02-2793-01	Inlet tube
31	no number	sump pan (see item 7)
32	02-1530-01	Clamp
33	13-0796-01	Rubber cap
34	02-2791-01	Water inlet nut
35	02-2606-01	Female tube
36	13-0617-02	O-ring
37	A30760-001	Screen
39	A35119-001	Water inlet assy.
40	13-0674-03	Tygon tube, 25" req.
41	02-2814-05	Hose clamp
42	12-2446-26	Inlet water valve
43	16-0670-02	Tee

CME1202 & CME1402 SERVICE PARTS

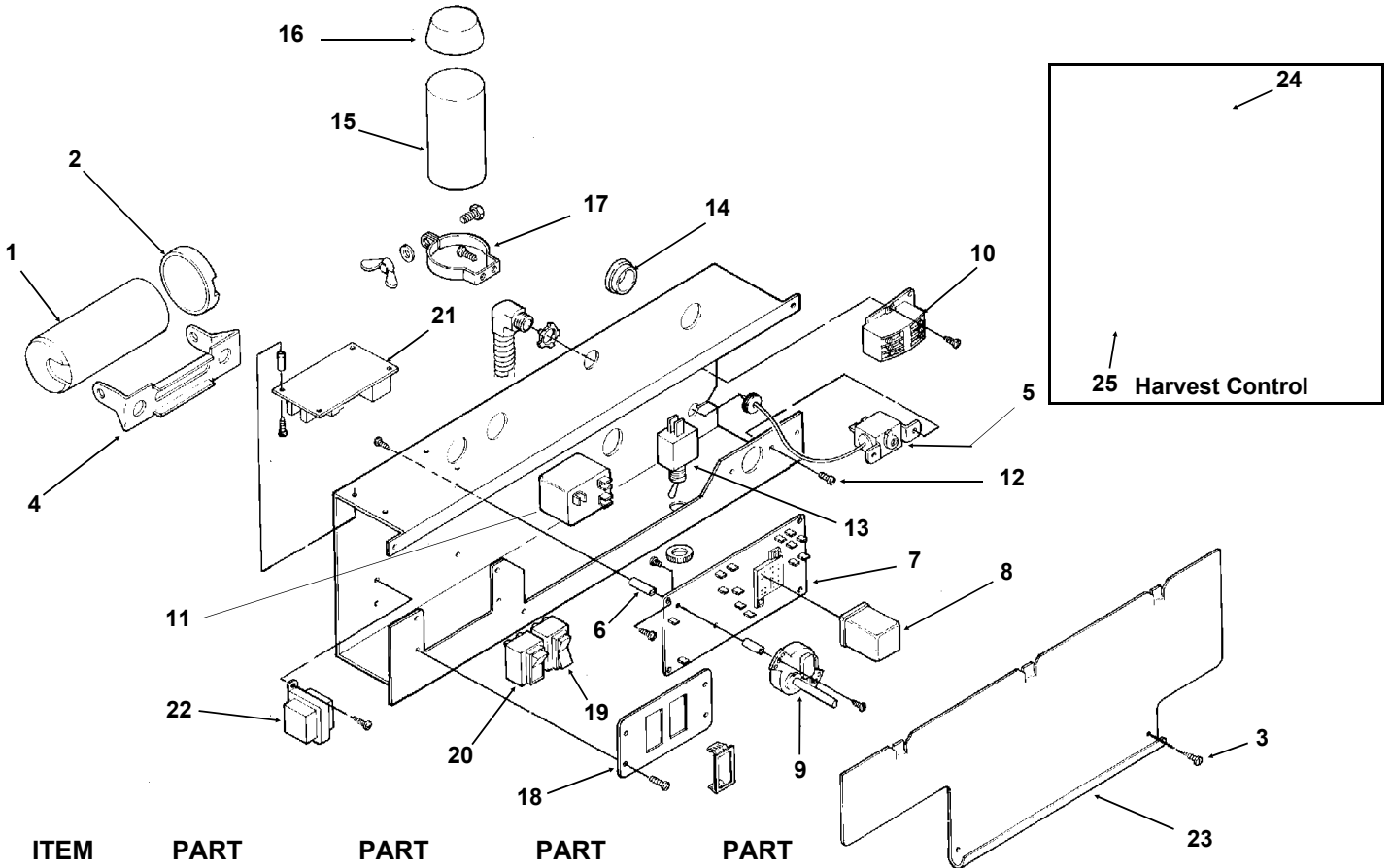

ITEM NUMBER	PART NUMBER	PART NUMBER	PART NUMBER	PART NUMBER	DESCRIPTION
	3 phase	single phase	single phase	single phase	
		1202 60 Hz	1402	1202 50 Hz	
1	-	18-1901-48	18-1901-27	same	Start Capacitor
2	-	A35328-001	same	same	Start Cap. Cap
3	-	03-1638-03	same	same	Screw
4	-	18-2200-39	same	same	Start cap. bracket
5	11-0351-22	same	same	same	Cube Size Control
6	02-2242-02	same	same	same	Stand off
7	12-1912-01	same	same	same	Circuit board
8	12-1879-03	same	same	same	Relay
9	12-2628-22	same	same	12-2628-26	Timer & Switch
10	12-0739-02	12-2469-02	same	same	Contactor
11	-	18-1903-46	same	same	Potential Relay
12	03-1403-17	same	same	same	Screw
13	12-0426-01	same	same	same	Comp. Switch
14	-	12-1213-12	same	same	Snap busing
15	-	18-1902-55	18-1902-56	18-1902-57	Run capacitor
16	-	13-0666-00	same	same	Terminal cover
17	-	A32872-001	same	same	Run Cap Bracket
18	02-3173-01	same	same	same	Switch plate
19	12-2414-01	same	same	same	Wash- Off - Ice switch
20	12-2411-01	same	same	same	Bin ice level switch
	12-2402-01	same	same	same	Wire harness, bin level switch to board
21	12-2376-21	same	same	same	Ice level control circuit board
22	12-2285-22	same	same	same	Transformer
23	A35082-001	same	same	same	Control box cover
24	11-0521-21	same	same	same	Harvest Thermostat (began May 1997)
25	12-2070-04	same	same	same	Relay for harvest thermostat

CME1202 & CME1402 SERVICE PARTS

BH900 ICE STORAGE BIN

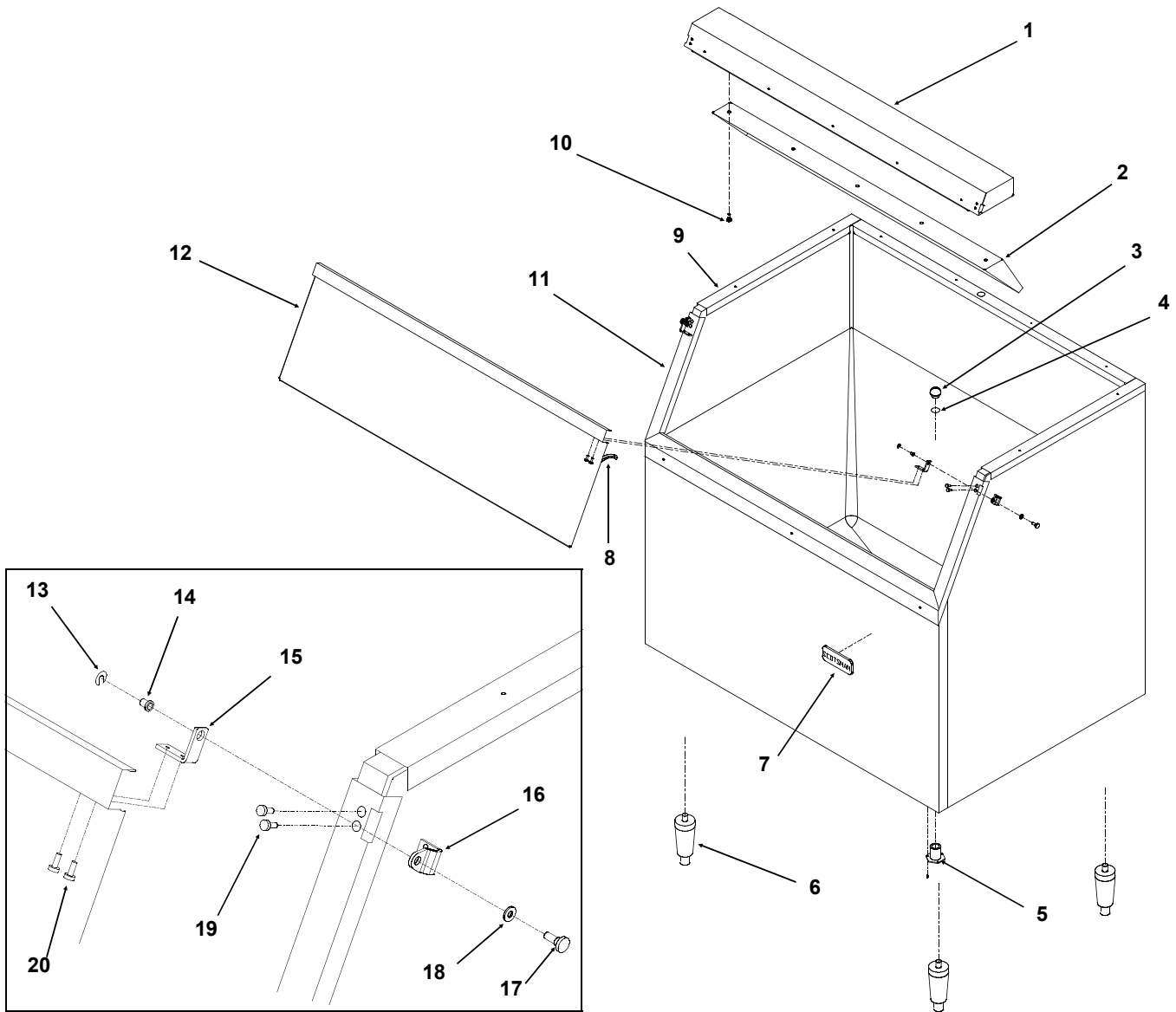

ITEM NUMBER	PART NUMBER	DESCRIPTION
1	A35322-020	Canopy Assembly
2	A35152-001	Ice Baffle
3	02-2809-01	Drain Top
4	13-0617-11	O-ring
5	02-3201-01	Drain casting
6	KLP2E	Leg Kit, Black
	KLP2S	Leg Kit, Nickel Plated
7	15-0711-01	Emblem
8	13-0595-00	Door gasket(6.25' reg.)
9	19-0503-04	Bin gasket
10	03-0727-11	Baffle screw
11	A35275-020	Door frame assy.
	A37641-021	Door frame, BH900S-C
12	A35323-001	Door with gasket
13	03-1539-09	"E" ring
14	02-2380-01	Hinge bushing

ITEM NUMBER	PART NUMBER	DESCRIPTION
15	02-3195-01	Door hinge
16	02-3196-01	Bin hinge
17	02-2806-01	Shoulder screw
18	02-2380-02	Spacer
19	03-1403-29	Screw 10-24
20	03-1403-24	Screw 10-24
21	02-0540-00	Scoop
22	A35280-001	Left bin channel
21a	A35311-001	Back bin channel
21b	A35279-001	Right bin channel

Note: There were a few BH900CE/CS type bins that used a different door, gasket, hinge & pin:

12	02-3222-01	Door, BH900CE / CS
	13-0595-01	Gasket, BH900CE / CS
	02-3225-01	Hinge kit, BH900CE / CS
	02-3226-01	Pivot pin set, BH900CE/CS

CME1202 & CME1402 SERVICE PARTS

Single Phase Wiring Diagram

A36249-001 THIS UNIT MUST BE GROUNDED
USE COPPER CONDUCTORS ONLY

CAUTION:
MORE THAN ONE DISCONNECT MEANS
MAY BE REQUIRED TO DISCONNECT
ALL POWER TO THIS UNIT.

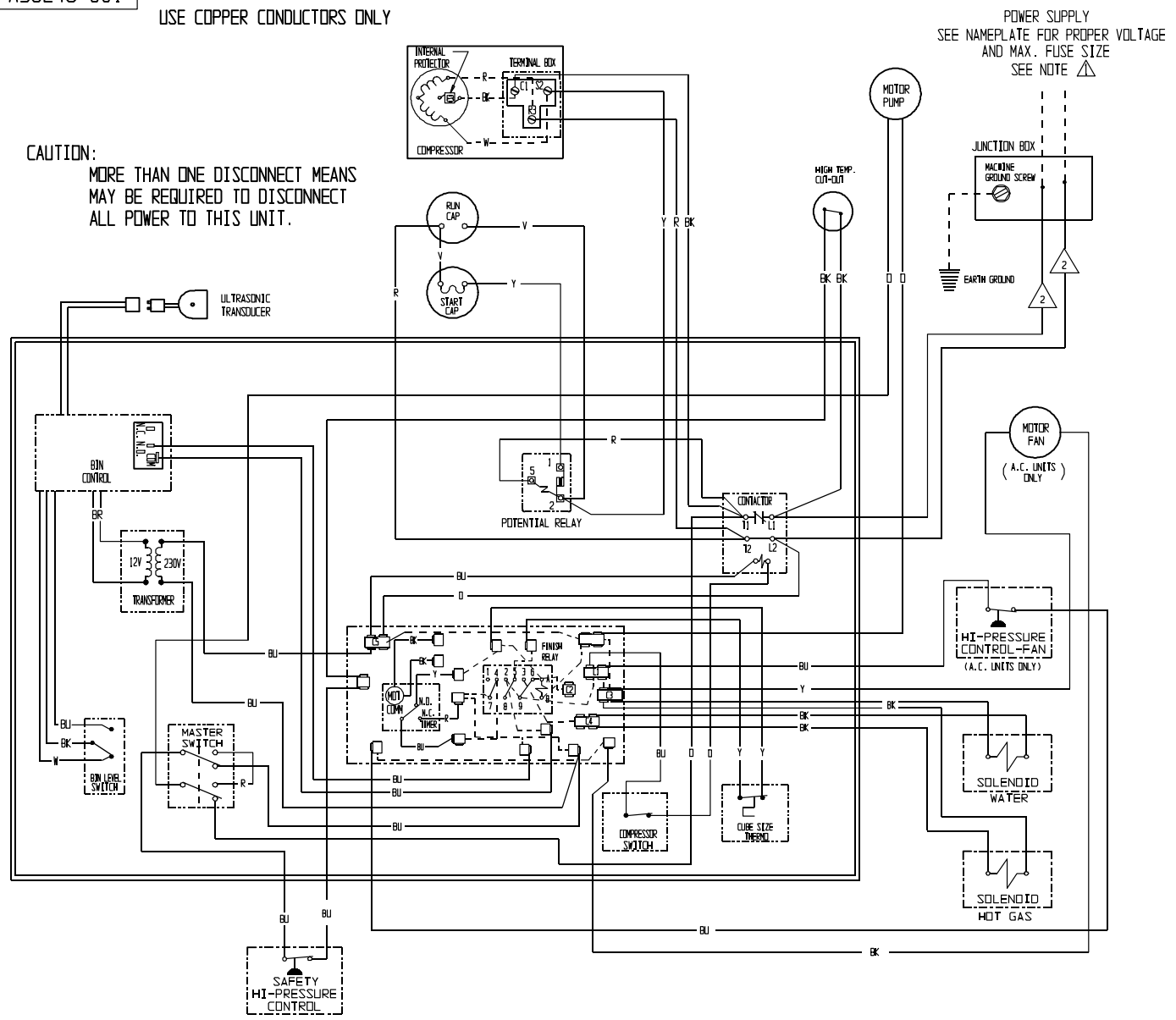

POWER SUPPLY
SEE NAMEPLATE FOR PROPER VOLTAGE
AND MAX. FUSE SIZE
SEE NOTE ⚠

CME1202 & CME1402 SERVICE PARTS

Single Phase Schematic Diagram

NOTES:

- ① DASHED LINES INDICATE FIELD WIRING WHICH MUST BE INSTALLED IN ACCORDANCE WITH THE NATIONAL ELECTRICAL CODE AND ALL STATE AND LOCAL CODES.
- ② WIRE COLOR FOR -32A (60 Hz) UNITS: BLACK
WIRE COLOR FOR -6A (50 Hz) UNITS : BROWN

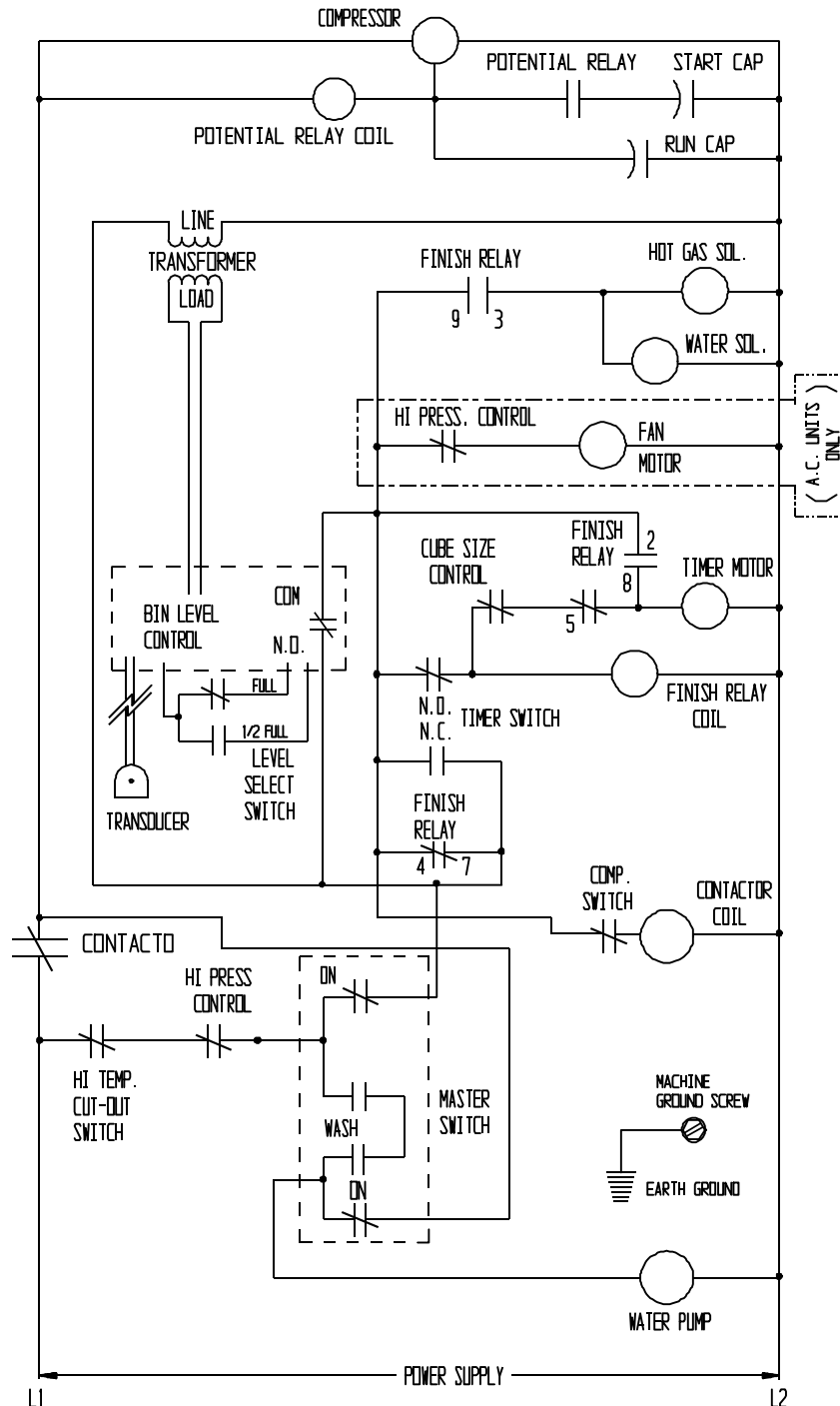

THIS UNIT SHOWN IN THE TIMED PORTION
OF THE FREEZING CYCLE

CME1202 & CME1402 SERVICE PARTS

3 Phase Wiring Diagram

A36249-003 THIS UNIT MUST BE GROUNDED
USE COPPER CONDUCTORS ONLY

CAUTION:
MORE THAN ONE DISCONNECT MEANS
MAY BE REQUIRED TO DISCONNECT
ALL POWER TO THIS UNIT.

SEE NAMEPLATE FOR
POWER SUPPLY VOLTAGE
AND MAX. FUSE SIZE
SEE NOTE Δ

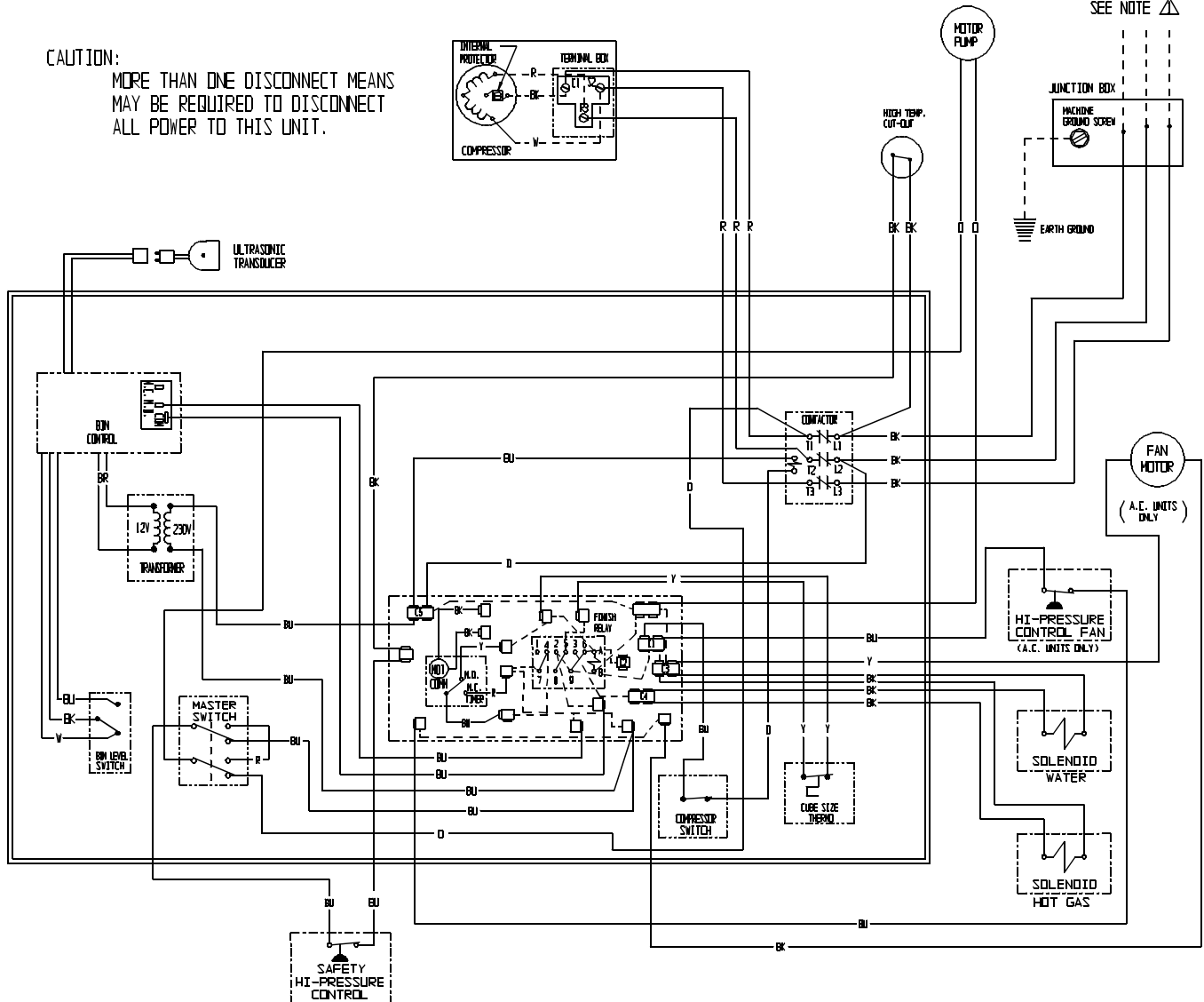

CME1202 & CME1402 SERVICE PARTS

3 Phase Schematic Diagram

NOTES:

△ DASHED LINES INDICATE FIELD WIRING WHICH MUST BE INSTALLED IN ACCORDANCE WITH THE NATIONAL ELECTRICAL CODE AND ALL STATE AND LOCAL CODES.

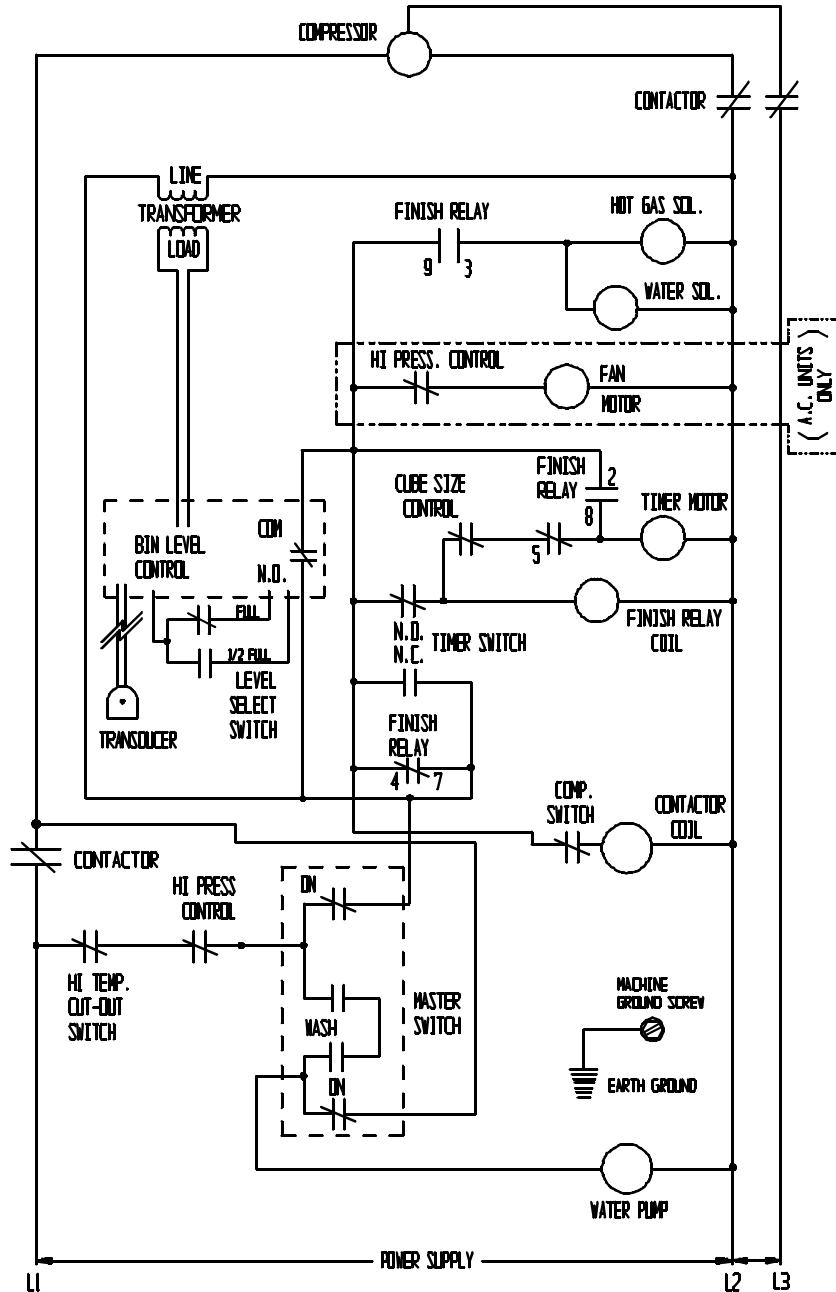

THIS UNIT SHOWN IN THE TIMED PORTION OF THE FREEZING CYCLE

CME1202 & CME1402 SERVICE PARTS

Single phase Wiring Diagram May 1997 production and later

17-2524-01 THIS UNIT MUST BE GROUNDED
USE COPPER CONDUCTORS ONLY

CAUTION:
MORE THAN ONE DISCONNECT MEANS
MAY BE REQUIRED TO DISCONNECT
ALL POWER TO THIS UNIT.

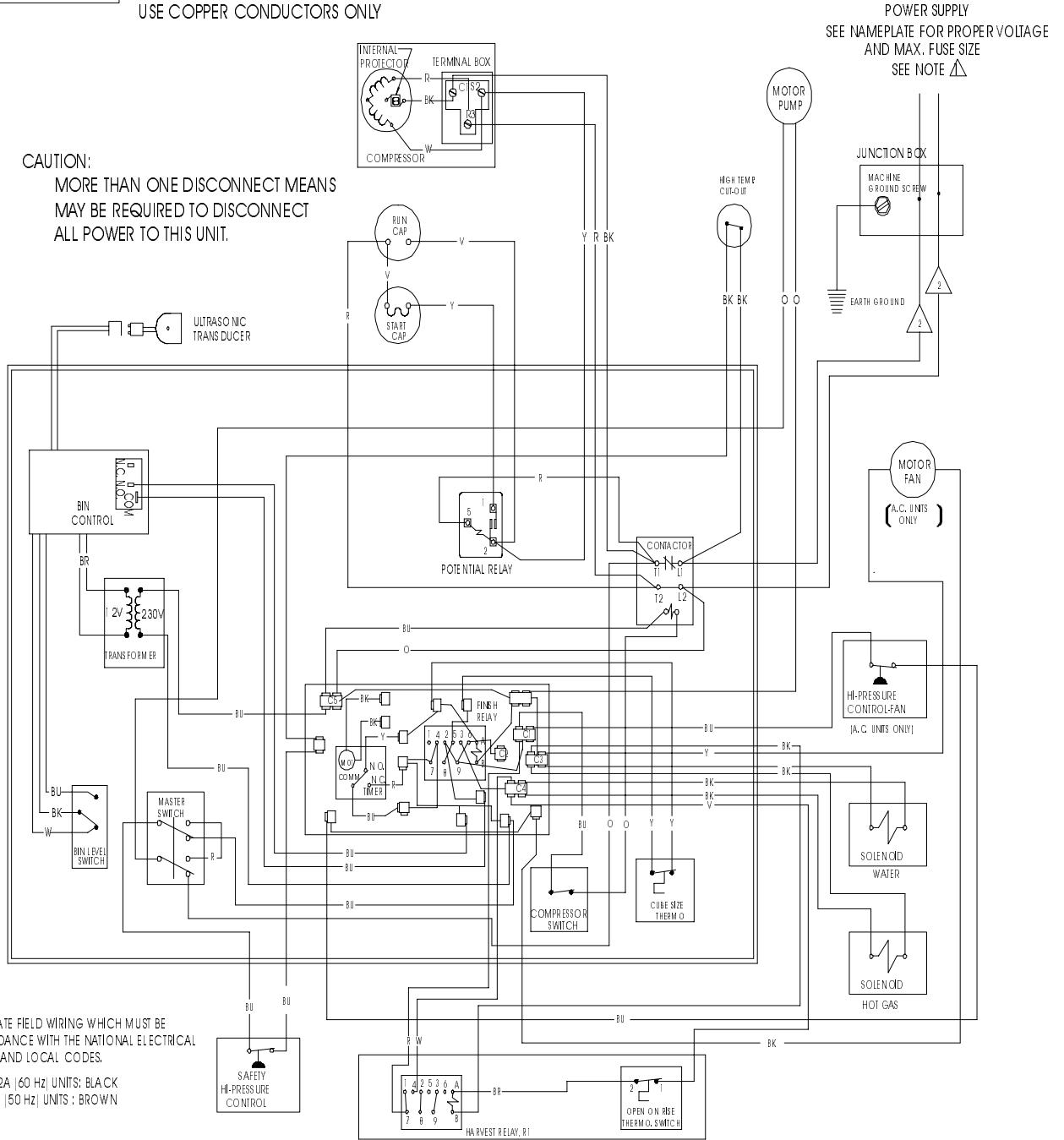

NOTES

DASHED LINES INDICATE FIELD WIRING WHICH MUST BE INSTALLED IN ACCORDANCE WITH THE NATIONAL ELECTRICAL CODE AND ALL STATE AND LOCAL CODES.

WIRE COLOR FOR -32A (60 Hz) UNITS: BLACK
WIRE COLOR FOR -6A (50 Hz) UNITS: BROWN

CME1202 & CME1402 SERVICE PARTS

Single phase Schematic Diagram May 1997 production and later

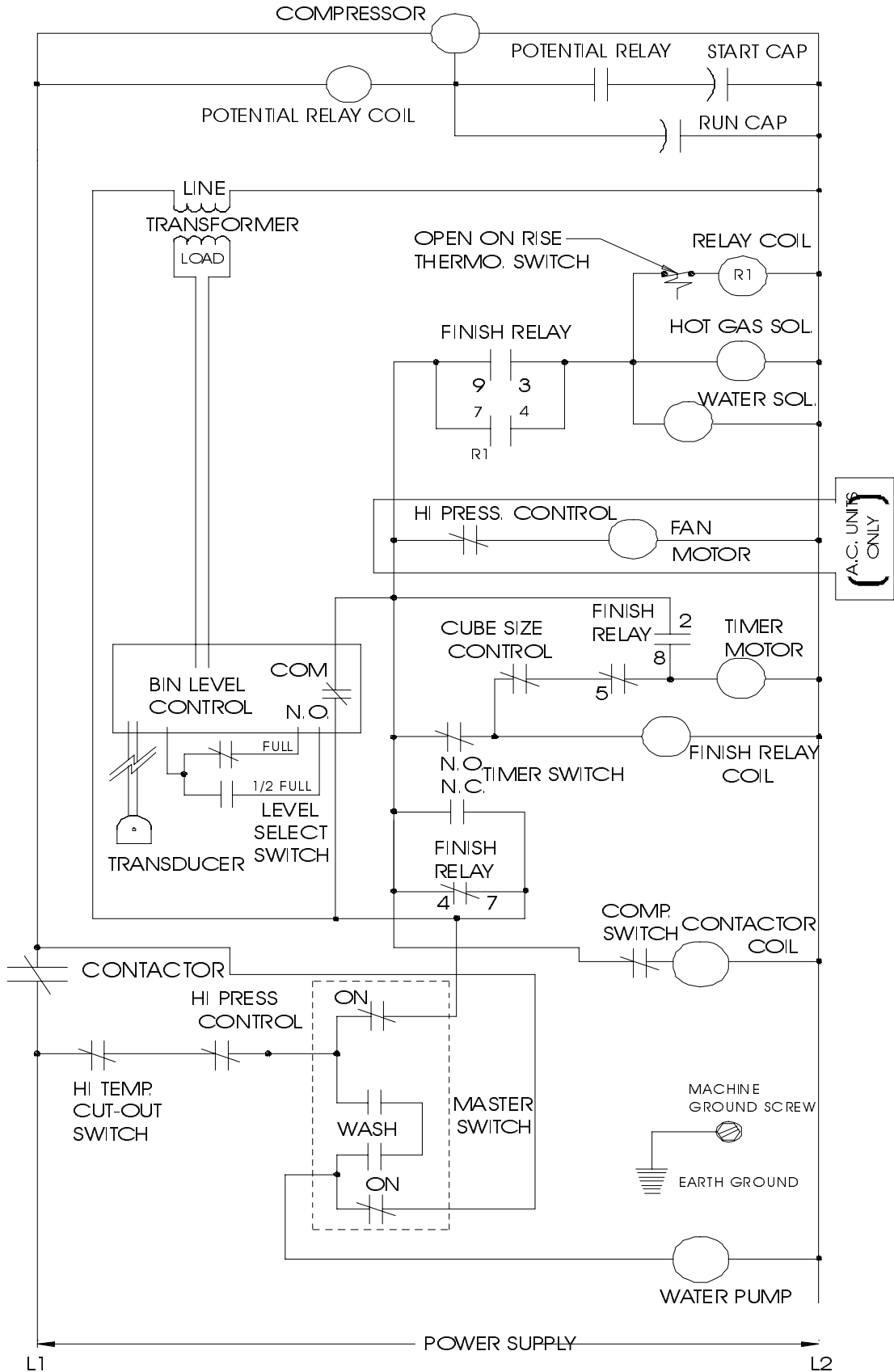

THIS UNIT SHOWN IN THE TIMED PORTION
OF THE FREEZING CYCLE

CME1202 & CME1402 SERVICE PARTS

3 phase Wiring Diagram May 1997 production and later

17-2525-03 THIS UNIT MUST BE GROUNDED
USE COPPER CONDUCTORS ONLY

SEE NAMEPLATE FOR
POWER SUPPLY VOLTAGE
AND MAX. FUSE SIZE
SEE NOTE Δ

CAUTION:
MORE THAN ONE DISCONNECT MEANS
MAY BE REQUIRED TO DISCONNECT
ALL POWER TO THIS UNIT.

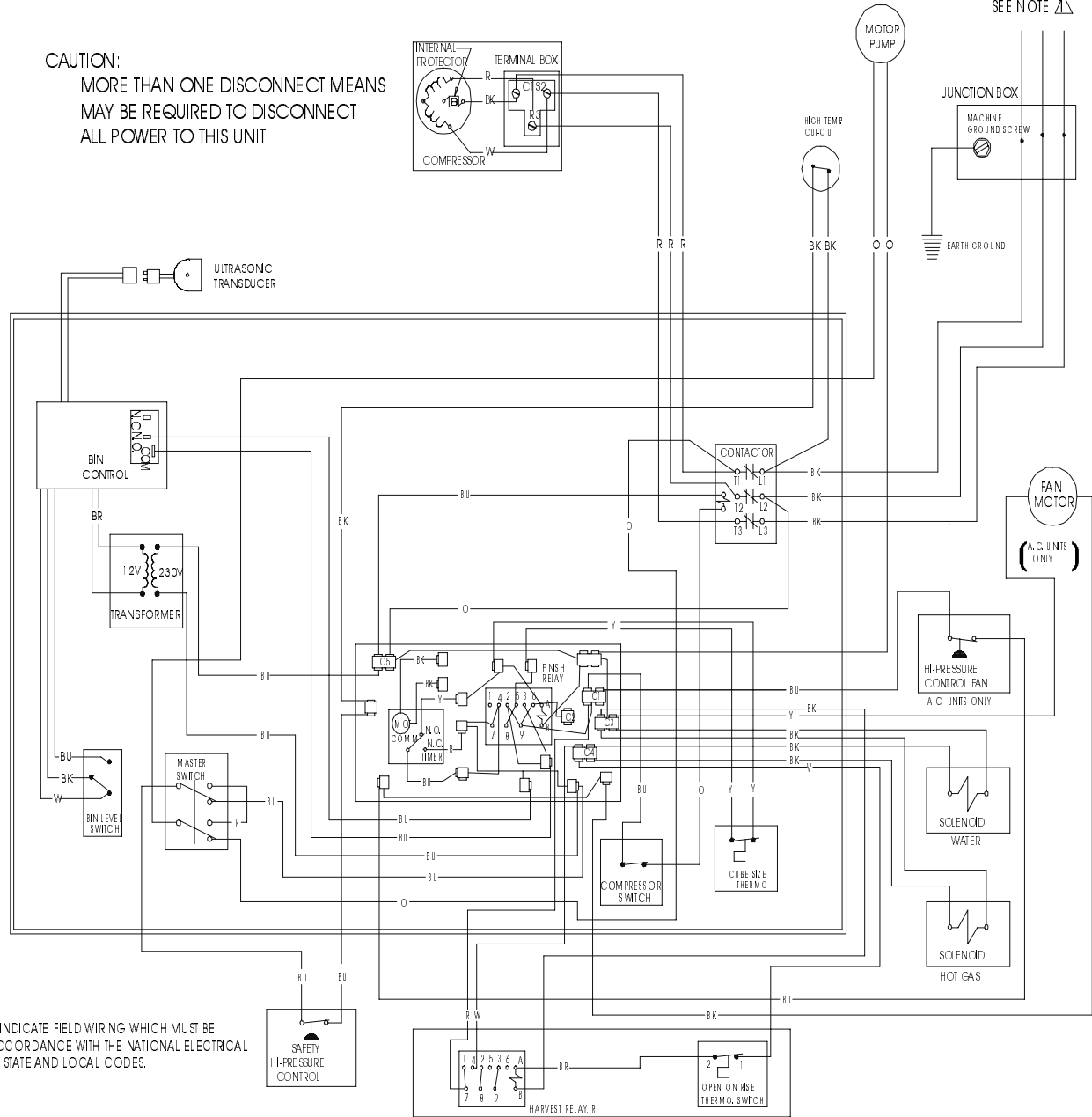

NOTES:
 Δ DASHED LINES INDICATE FIELD WIRING WHICH MUST BE
INSTALLED IN ACCORDANCE WITH THE NATIONAL ELECTRICAL
CODE AND ALL STATE AND LOCAL CODES.

CME1202 & CME1402 SERVICE PARTS

3 phase Schematic Diagram May 1997 production and later

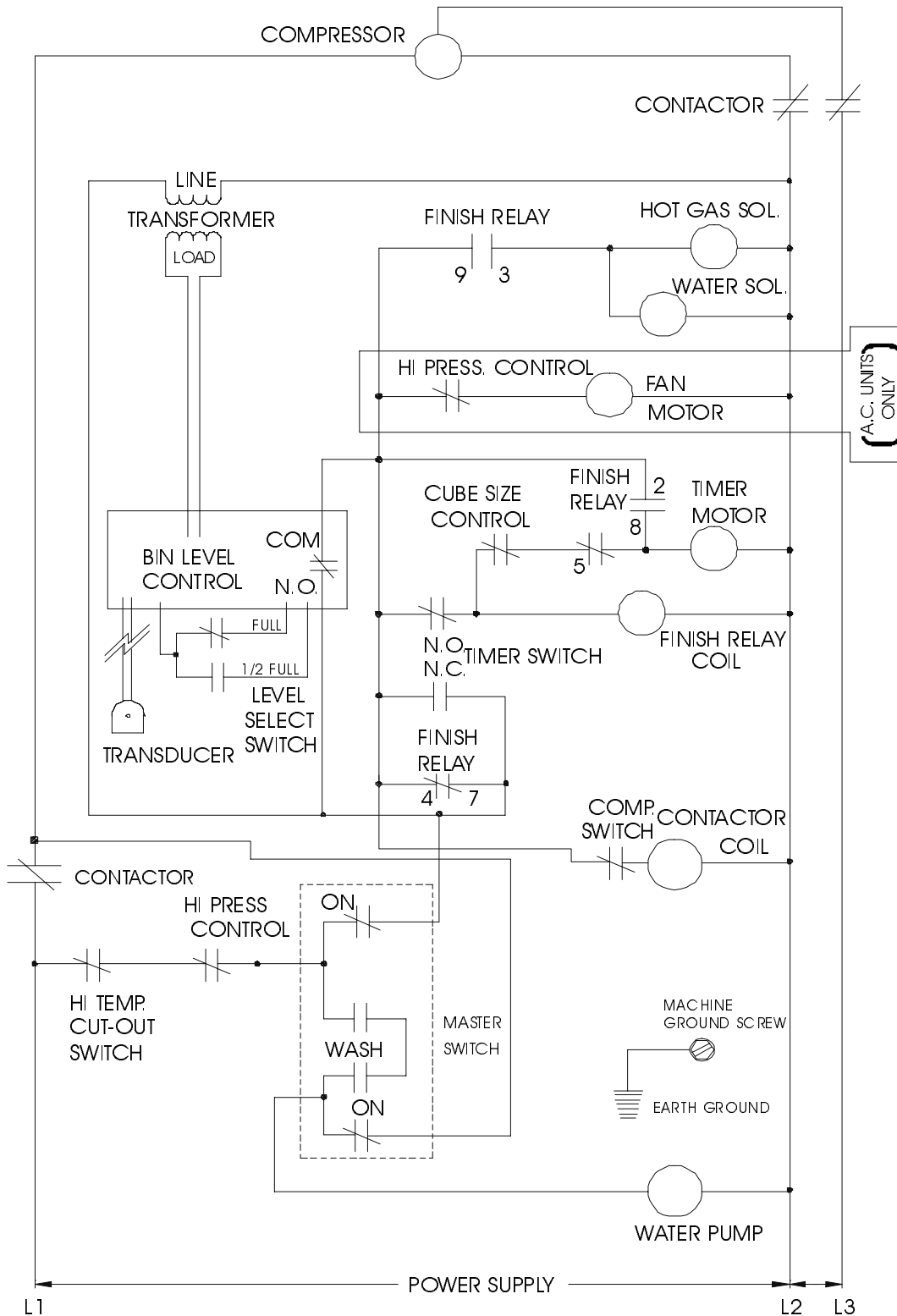

THIS UNIT SHOWN IN THE TIMED PORTION
OF THE FREEZING CYCLE