

# CME2006R Service Parts

This parts list contains the part numbers and description of the replacement parts available for this model. To avoid costly and time consuming errors, double check the model and voltage before ordering a part.

## Table of Contents

Cabinet . . . . . page 2

Water System . . . . . page 3

Refrigeration System . . . . . page 4

Electrical . . . . . page 5

ERC611 . . . . . page 6

BH900 . . . . . page 7

BH1650 . . . . . page 8

Kit Parts . . . . . page 9

Wiring Diagrams . . . . . page 10

# CME2006R Service Parts

## Cabinet

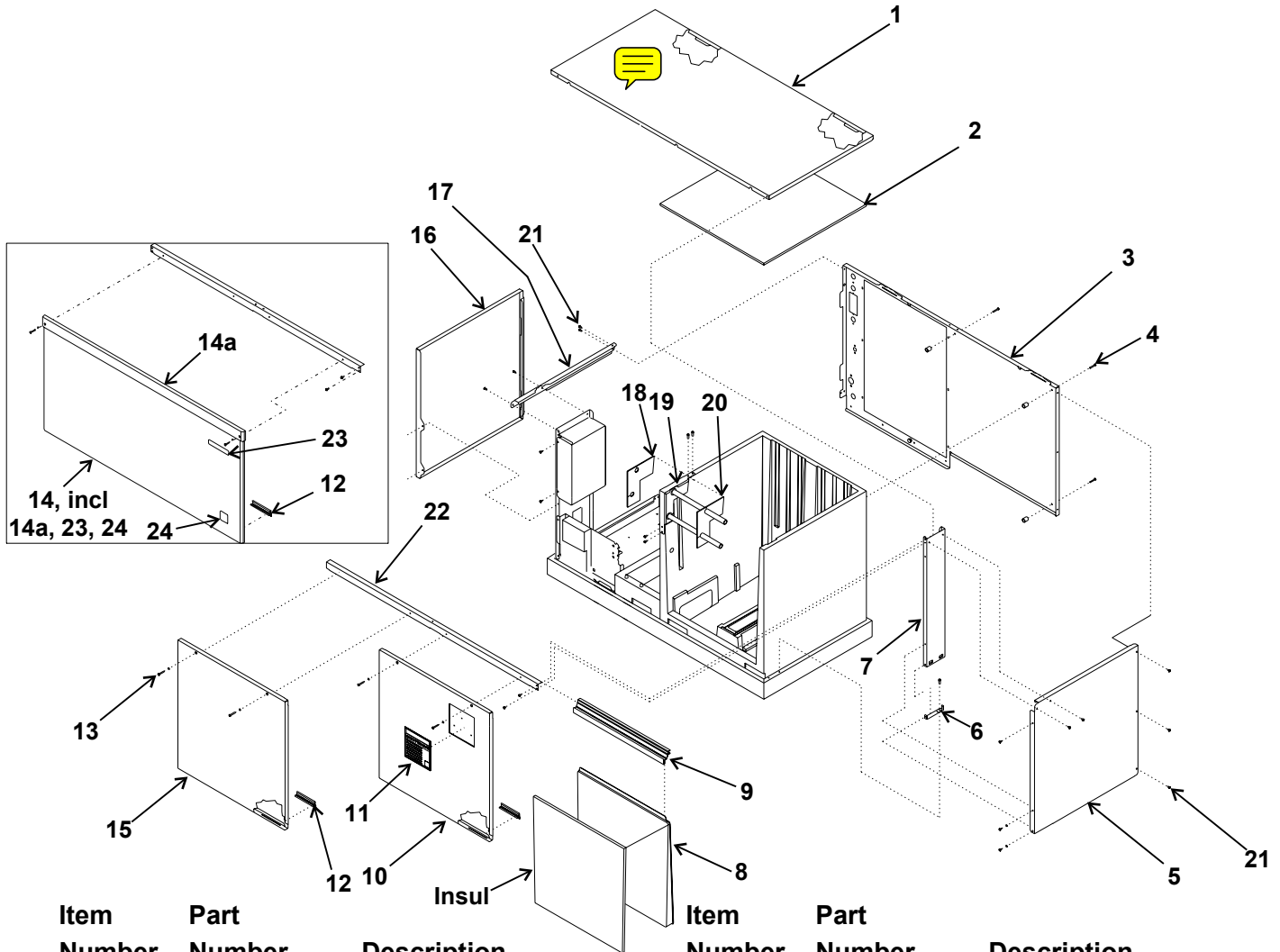

Item Number	Part Number	Description	Item Number	Part Number	Description
1	A37202-015	Top panel, Grey	14	A37489-002	One piece front panel, grey
	A37202-002	Top panel, SS		A37489-001	One piece front panel, SS
	02-3823-21	Top panel, plastic for C and D series. Will not fit A or B series.	14	03-1735-01	Screw for above panels
2	02-3686-01	Insulation	15	A37201-015	24" Left front panel, grey
3	A37197-001	Back panel		A37201-002	24" Left front panel, SS
4	03-1404-37	Screw	15a	02-3794-02	Trim strip
5	A37199-015	Right side panel, grey		03-1731-02	Push nut for trim strip
	A37199-002	Right side panel, SS	16	A37198-015	Left side panel, grey
6	A37194-001	Right bottom channel		A37198-002	Left side panel, SS
7	A37213-001	Right side support	17	A37365-001	Left side channel
8	02-3702-21	Evaporator cover & insulation	18	02-3696-03	Left grommet
9	02-3701-01	Cover retainer	19	A37216-001	Bracket
10	A37200-015	24" Right front panel, grey	20	02-3696-02	Right grommet
	A37200-002	24" Right front panel, SS	21	03-1531-01	Screw
11	15-0790-01	Emblem	22	A37195-001	Channel, front top
12	02-3699-01	Panel support clip	23	15-0808-03	Scotsman emblem
13	03-1735-01	Front panel screw	24	15-0792-02	CM <sup>3</sup> emblem

# CME2006R Service Parts

## Water System

Item Number	Part Number	Description
1	02-3613-01	Elbow
2	02-3725-01	Hose clamp
3	13-0617-48	O-ring
4	02-3518-01	Manifold
5	02-3519-01	Manifold right
6	13-0840-01	Plug
7	02-2527-01	Water distributor
8	A37315-021	Evaporator
9	02-3337-02	Ice deflector
10	02-3672-01	Right trough
11	02-3672-02	Left trough
12	A37337-001	Evap support
13	11-0540-21	Ice sensor (set)
14	02-3689-01	Ice sensor holder
15	02-3706-01	Upper inner splash

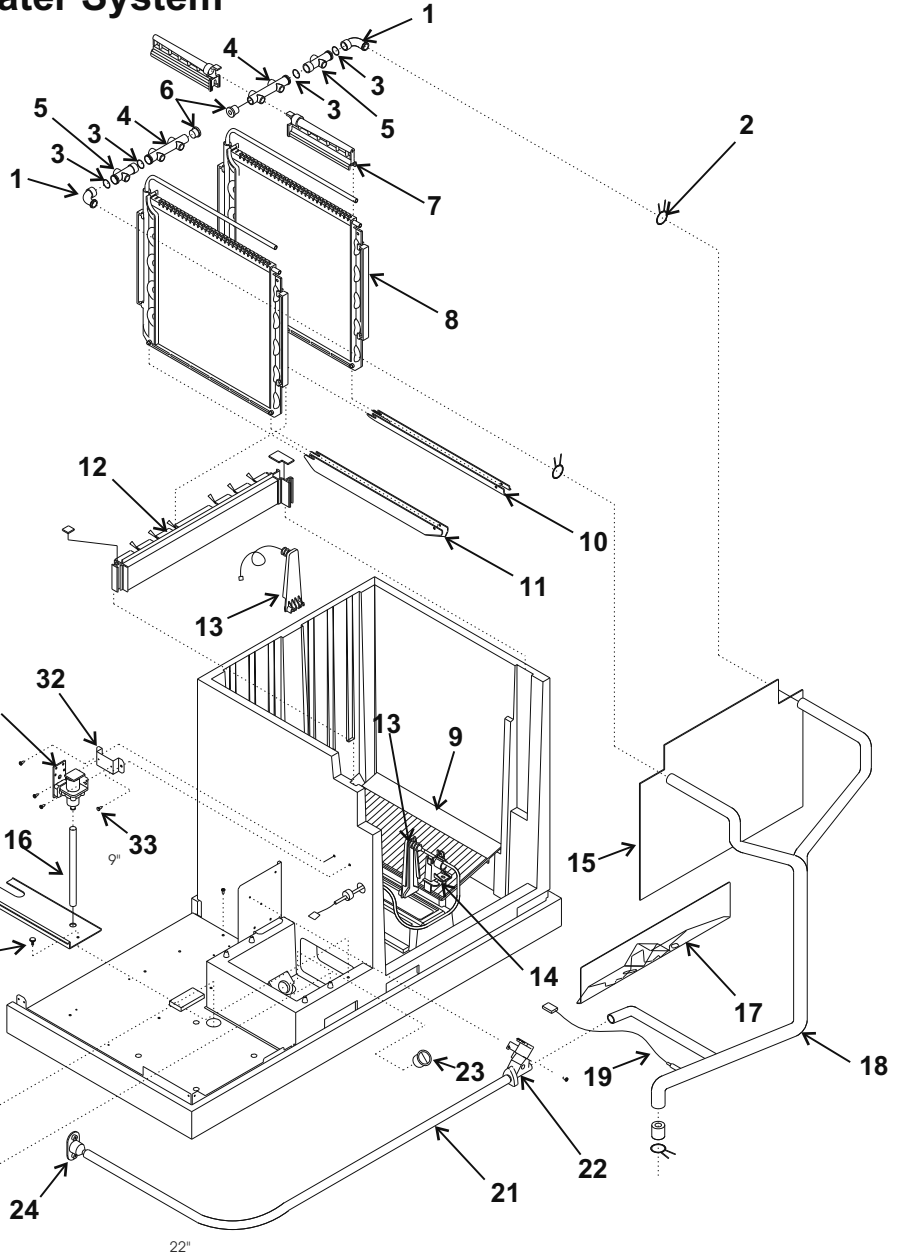

16	13-0674-02	Tube, order 1 unit	27	11-0539-51	Water level sensor
17	02-3680-01	Lower inner splash panel	28	12-2666-01	Water solenoid valve
18	02-3660-01	Water discharge hose		16-0355-00	Coupling half
19	11-0515-21	Temp sensor set	29	12-2665-01	Harness for water sensor
20	02-3383-06	Float stem	30	02-3388-05	Pump bracket
21	13-0674-06	Drain hose, order 2 units	31	12-2582-21	Water pump
22	11-0514-01	Purge valve	32	A37204-001	Bracket
23	02-3703-01	Drain plug	33	03-1404-18	Screw
24	02-3692-21	Drain fitting	34	03-1691-01	Nylon screw
25	02-3341-01	Float	35	02-3534-01	Reservoir cover
26	02-3388-04	Pump bracket			

# CME2006R Service Parts

## Refrigeration

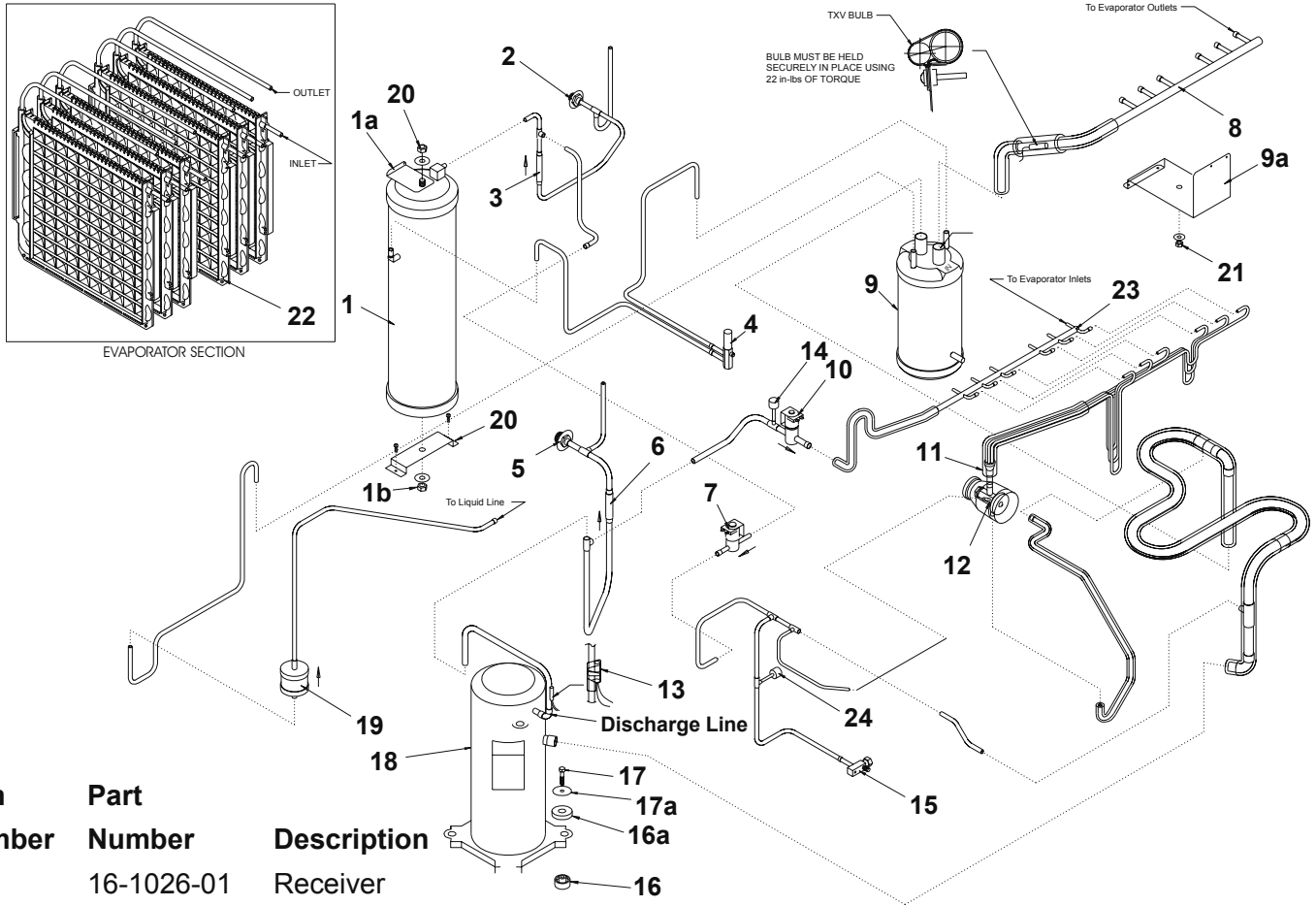

Item Number	Part Number	Description
1	16-1026-01	Receiver
1a	A37211-001	Top receiver bracket
1b	A37212-001	Bottom receiver bracket
2	16-0850-03	Liquid line fitting
3	16-1029-01	Liquid line check valve
4	16-1030-01	Liquid line access valve
5	16-0850-01	Discharge line fitting
6	16-1028-01	Discharge check valve
7	12-2471-22	Harvest bypass valve
7a	16-1063-01	Strainer for bypass valve
8	16-1055-01	Suction manifold
9	16-1054-22	Accumulator w/insul.
9a	A37402-001	Accumulator support
10	11-0507-23	Hot gas valve w/coil
	12-2719-23	Hot gas valve coil only
10a	16-1063-03	Strainer for HGV
11	A37405-001	Distributor and tubes
12	16-1041-21	TXV, AAE 2 5Z
	02-3396-01	Insulation for TXV
13	11-0515-21	Temp sensor set
14	11-0501-22	Hi pressure cut out
15	16-0832-20	Suction access valve
	16-0832-03	Port cap
	16-0832-02	Stem cap
16	03-1729-01	Solid Mount
16a	03-1729-03	Rubber pad
	03-3843-01	Rubber grommet
17	03-1405-20	Bolt
	18-2300-26	Sleeve for rubber grommet
17a	03-1729-02	Washer for solid mount
	03-1407-07	Washer for rubber grommet
18	18-8821-21	Compressor, 60 Hz, single phase
	18-8821-22	Compressor, 60 Hz, 3 phase
	18-8828-01	crankcase heater for 3 phase
	Replacement compressors include a dryer	
19	02-3319-02	Dryer
20	03-1406-13	Nut
21	03-1406-12	Nut
22	A37315-021	Evaporator
23	16-1050-01	Hot gas header
24	11-0502-21	Low pressure cut out

# CME2006R Service Parts

## Electrical

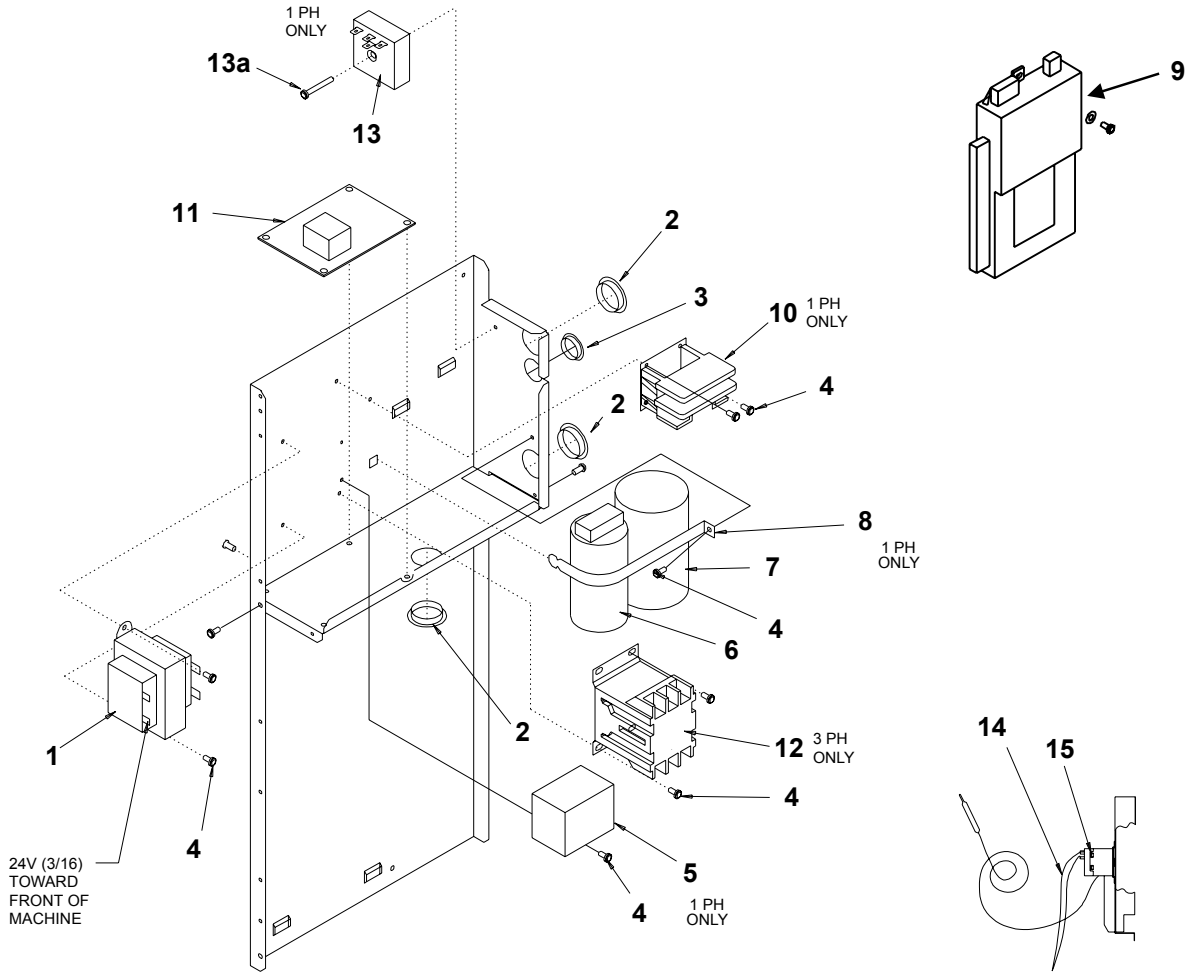

Item Number	Part Number	Description
1	A37217-001	Transformer
2	12-1213-11	Snap bushing
3	12-1213-10	Snap bushing
4	03-1531-01	Screw
5	18-1903-55	60 Hz potential relay
6	18-1902-59	Run capacitor
7	18-1901-58	60 Hz start capacitor
8	A37366-001	Strap
9	12-2838-23	Controller
10	12-2595-01	Single phase contactor
11	11-0531-22	Purge valve timer
12	12-2533-01	3 phase contactor
13	11-0530-01	Time delay relay
13a	03-1531-10	Screw

Item Number	Part Number	Description
14	12-2701-01	Bin thermo harness
15	11-0521-21	Bin thermostat
Not Shown:		
	02-3740-01	Thermostat bracket
	03-1675-03	3 pronged knob
	12-2663-02	Lo voltage harness
	12-2732-01	Hi voltage harness

# CME2006R Service Parts

## ERC611 Remote Condenser

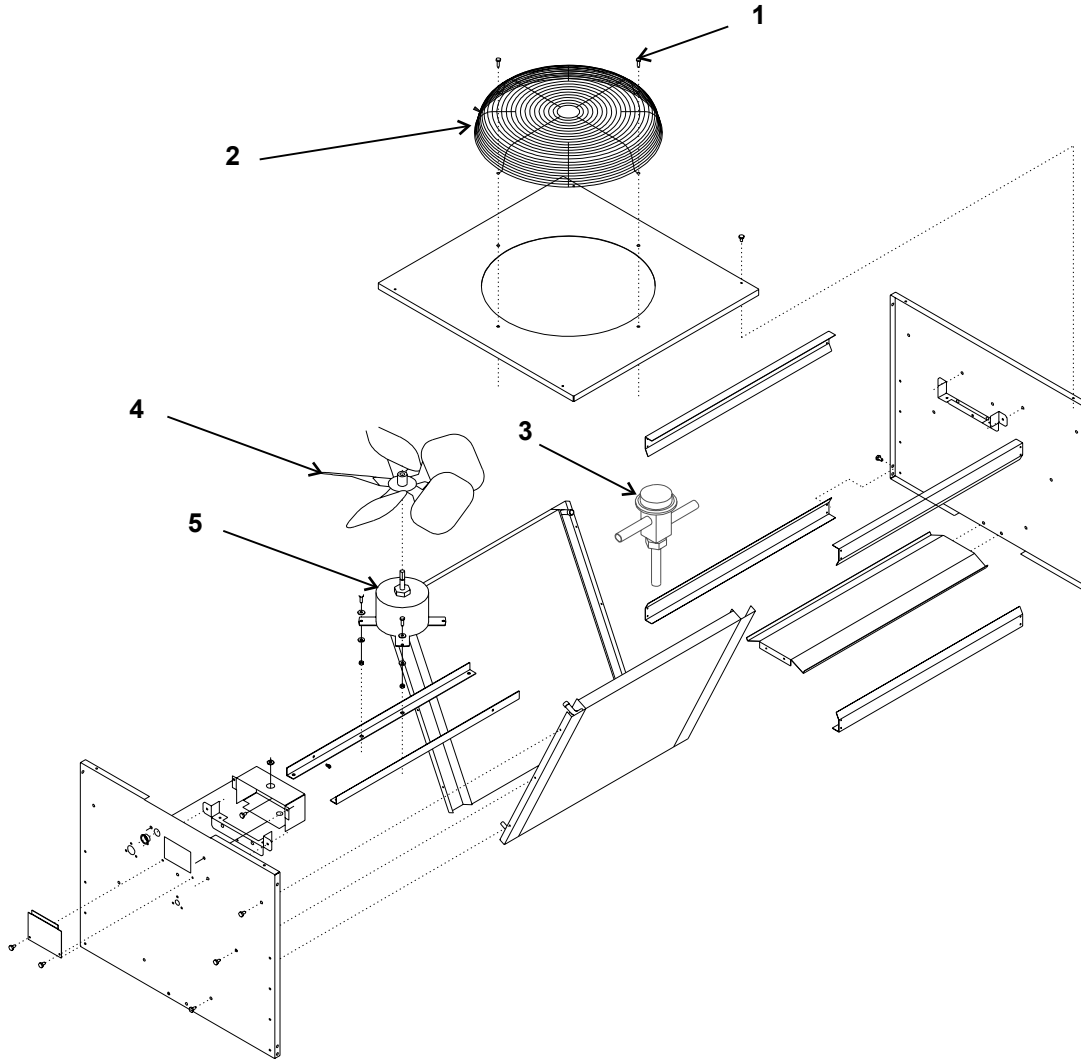

Item Number	Part Number	Description
1	03-1405-08	Screw
2	02-3770-01	Fan guard
3	16-1044-01	Headmaster
4	18-8820-01	Fan blade
5	12-2717-01	Fan motor

### Not Shown:

A37169-001	Leg
A37296-001	Leg brace
03-1645-01	Screw for legs
16-0850-01	Quick connect, discharge
16-0850-03	Quick connect, liquid

# CME2006R Service Parts

## BH900 Ice Storage Bin

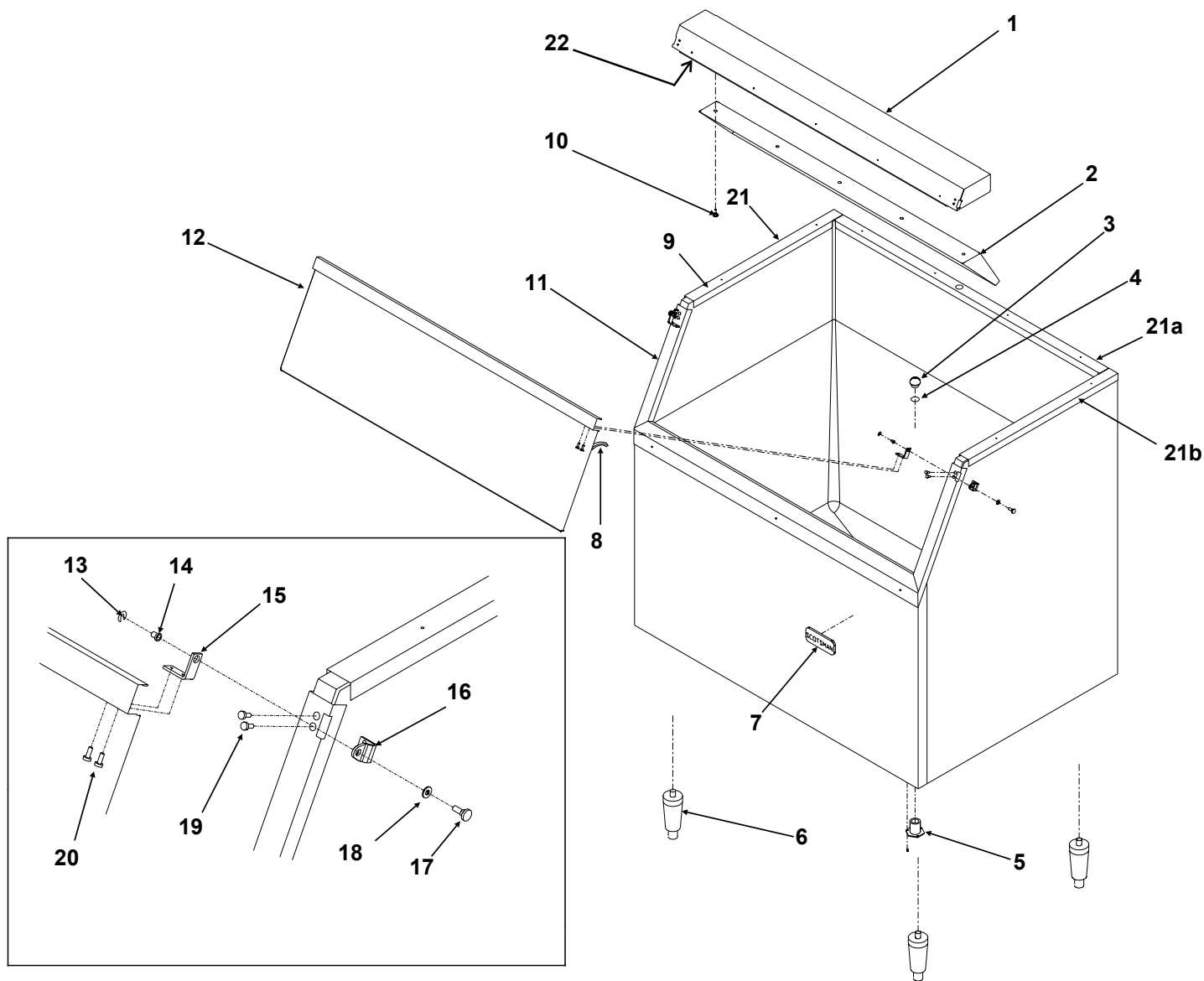

ITEM NUMBER	PARTS NUMBER	DESCRIPTION
1	A35322-020	Canopy Assembly
2	A35152-001	Ice Baffle
3	02-2809-01	Drain Top
4	13-0617-11	O-ring
5	02-3201-01	Drain casting
6	KLP2E	Leg Kit, Black
	KLB2S	Leg kit, nickel plated
7	15-0711-01	Emblem
8	13-0595-00	Door gasket (order qty 7)
9	19-0503-04	Bin gasket (order by foot)
10	03-0727-11	Baffle screw
11	A35275-001	Door frame assy.
	A37641-021	Frame, for BH900S-C
12	A35323-020	Door with gasket - BH900

13	03-1539-09	"E" ring
14	02-2380-01	Hinge bushing
15	02-3195-01	Door hinge
16	02-3196-01	Bin hinge
17	02-2806-01	Shoulder screw
18	02-2380-02	Spacer
19	03-1403-29	Screw 10-24
20	03-1403-24	Screw 10-24
21	A35280-001	Left bin channel
21a	A35311-001	Back bin channel
21b	A35279-001	Right bin channel
22	02-3202-01	Trim guard
BH900CE or CS used a different door, hinge & pin:		
12	02-3222-01	Door
	02-3225-01	Hinge kit
	02-3226-01	Pivot pin set

# CME2006R Service Parts

## BH1650 Ice Storage Bin

"Z" Brackets are used when attaching CME1356 or CME1656 to bin. Attaching screw pn: 03-1645-01

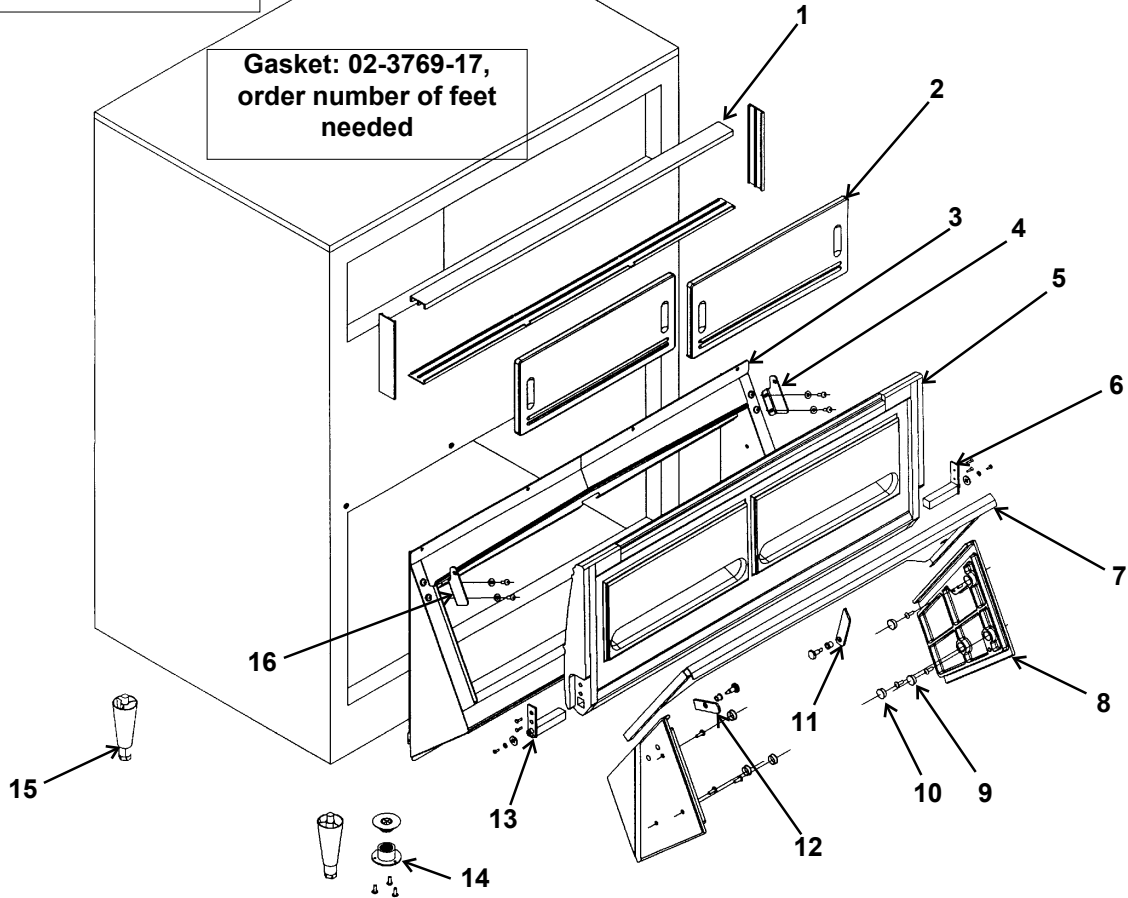

Item Number	Part Number	Description	Item Number	Part Number	Description
1	02-3769-02	Track	10	02-3769-14	Plugs for end plate
2	02-3769-16	Window	11	02-3769-10	Catch for ice gate
3	02-3769-04	Lower frame assembly	12	02-3769-15	Ice gate retainer
4	02-3769-08	Left and right hinges	13	02-3769-06	Left hinge
5	02-3769-05	Door with door hinges	14	02-3769-01	Plastic drain
6	02-3769-07	Right hinge	15	KLP2S	Legs
7	02-3769-09	Ice gate	Not Illustrated:		
8	02-3769-12	End plate guide (pair)		02-3769-18	Probe tool
9	02-3769-13	Screws for end plate		02-3769-19	Plastic Ice shovel.
				02-3775-01	Z brackets



# CME2006R Service Parts

## Kit Parts

Stacking Kit - KSCME6-LG-B

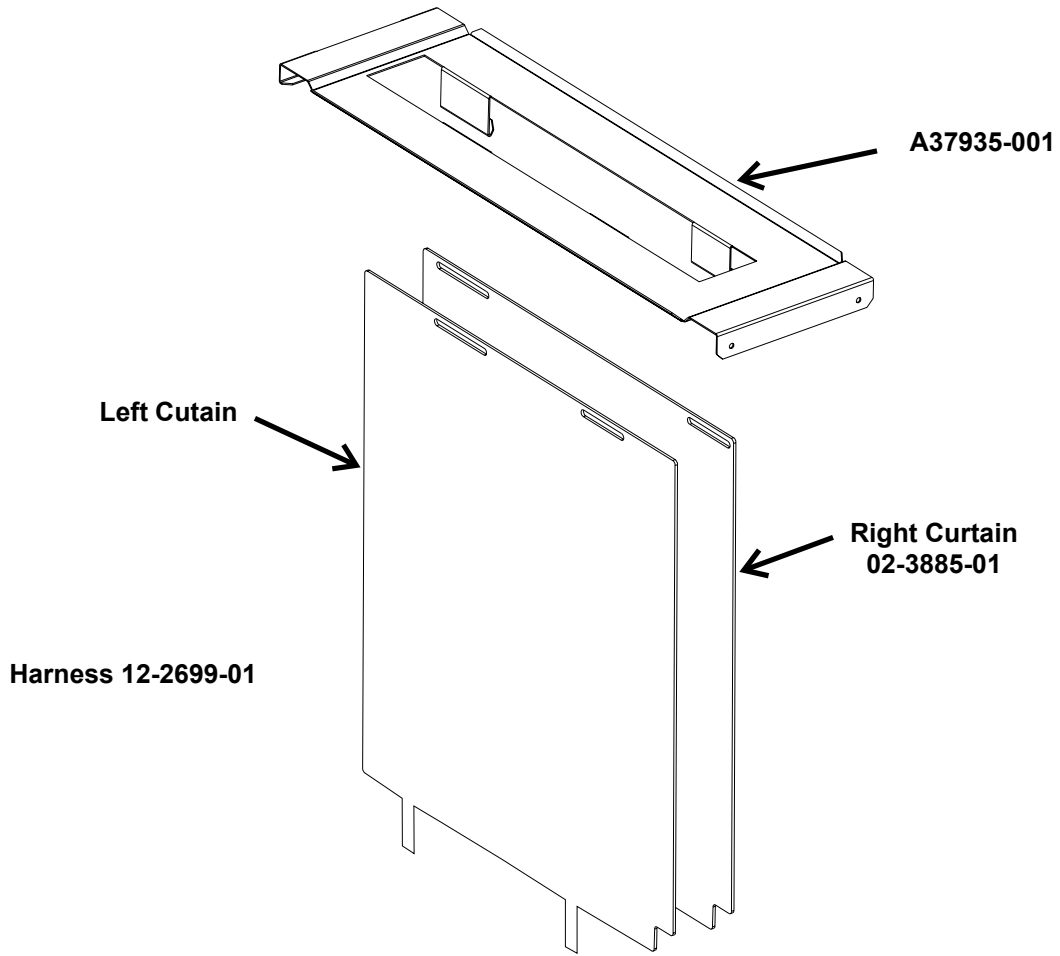

# CME2006R Service Parts

## Single Phase Wiring Diagram

17-2633-01

USE COPPER CONDUCTORS ONLY

▲ DASHED LINES INDICATE FIELD WIRING WHICH MUST BE INSTALLED IN ACCORDANCE WITH THE NATIONAL ELECTRICAL CODE AND ALL STATE AND LOCAL CODES.

▲ WIRE COLOR FOR 208-230/60/1 UNITS: BLACK  
WIRE COLOR FOR 230/50/1 UNITS : BROWN

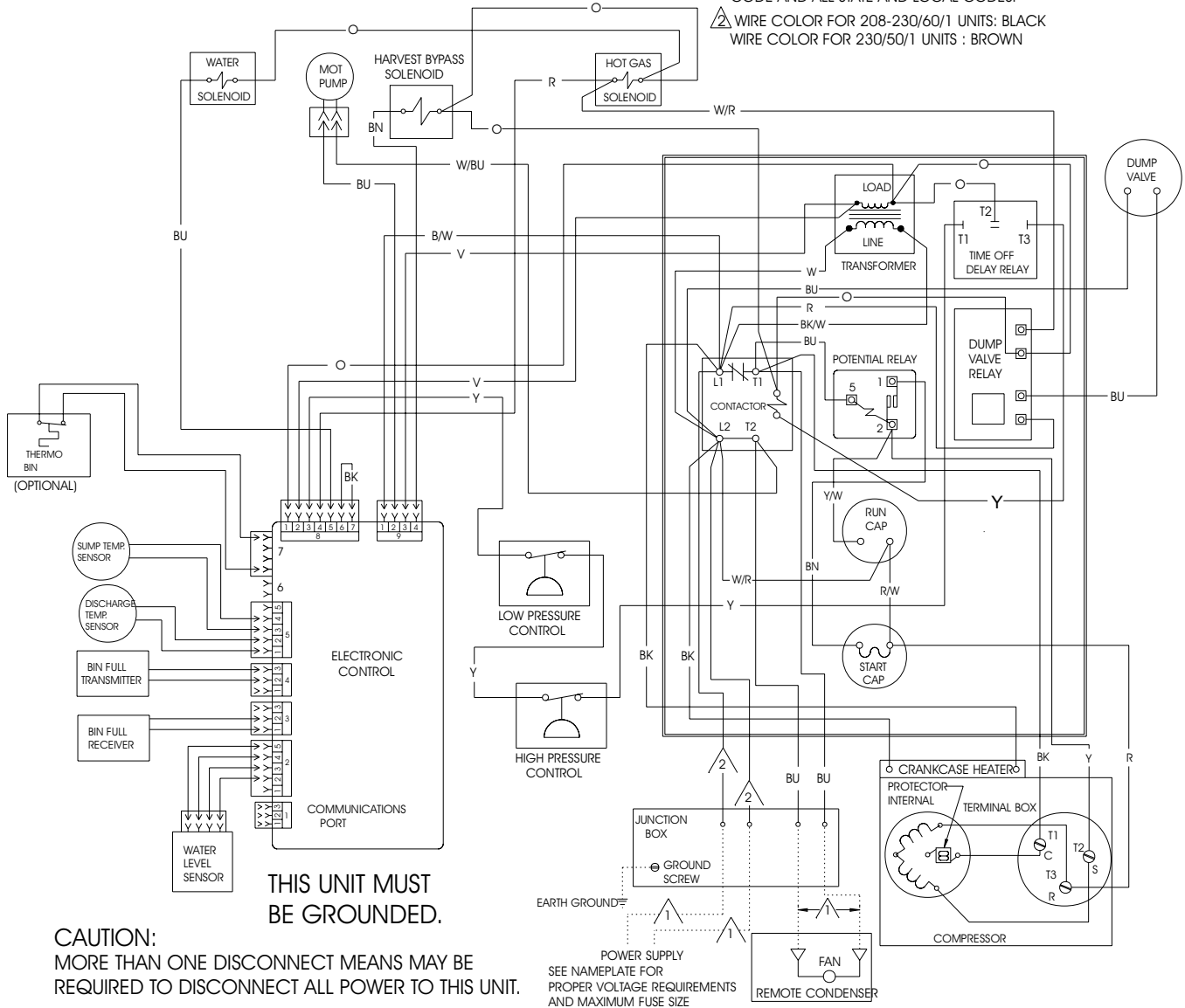

**CAUTION:**  
MORE THAN ONE DISCONNECT MEANS MAY BE  
REQUIRED TO DISCONNECT ALL POWER TO THIS UNIT.

# CME2006R Service Parts

## Single Phase Schematic Diagram

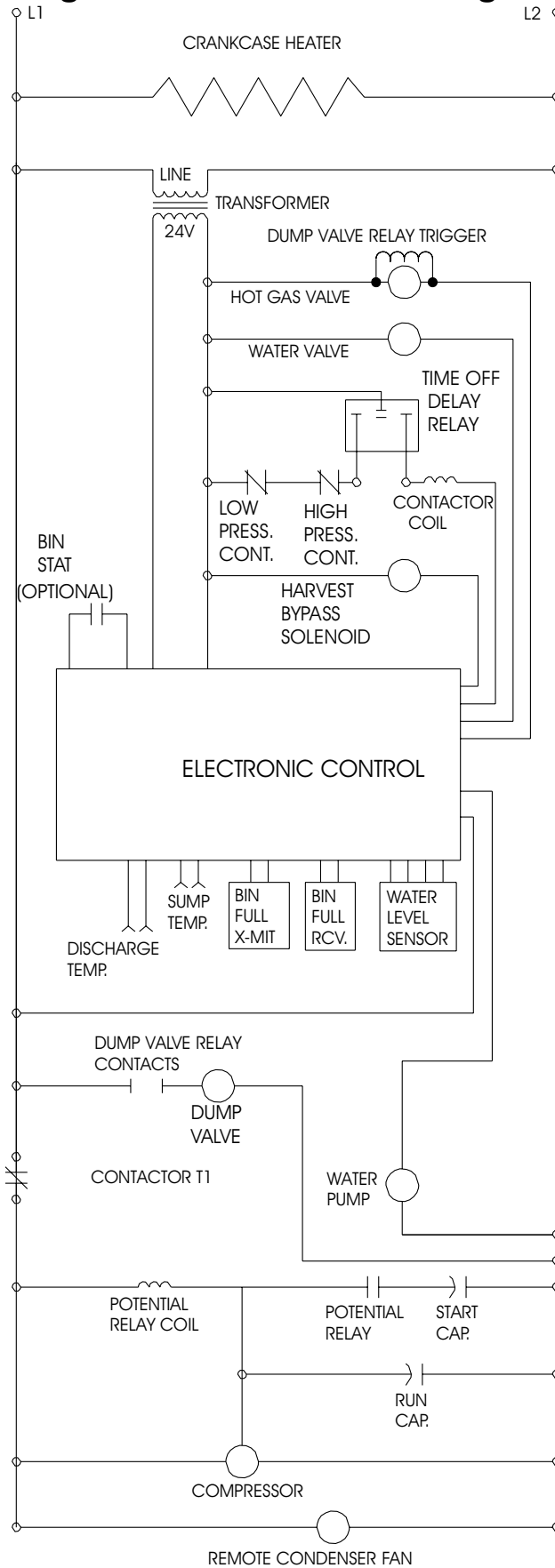

# CME2006R Service Parts

## Three Phase Wiring Diagram

17-2626-01

**USE COPPER CONDUCTORS ONLY**

⚠ DASHED LINES INDICATE FIELD WIRING WHICH MUST BE INSTALLED IN ACCORDANCE WITH THE NATIONAL ELECTRICAL CODE AND ALL STATE AND LOCAL CODES.

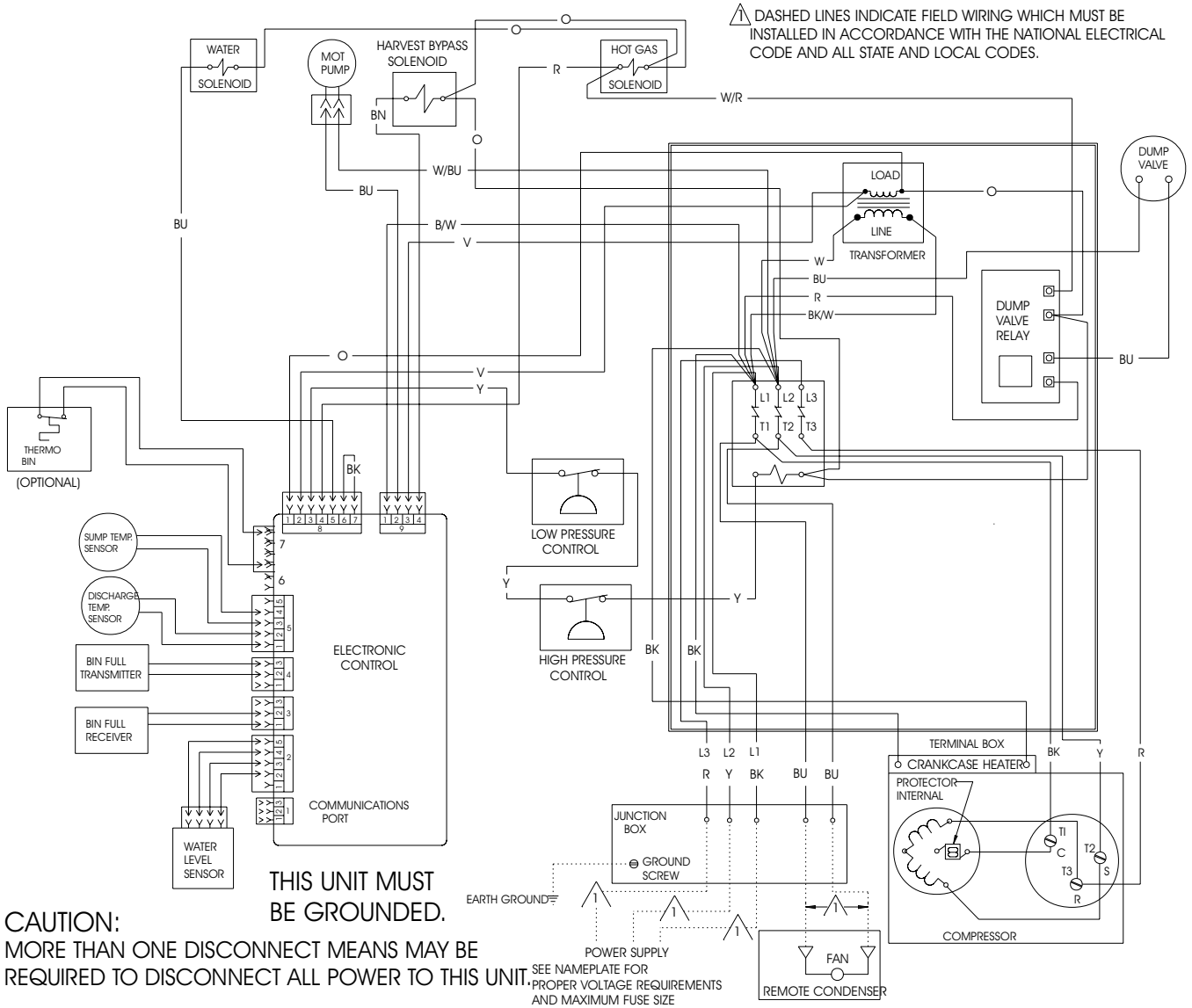

**CAUTION:**  
 MORE THAN ONE DISCONNECT MEANS MAY BE  
 REQUIRED TO DISCONNECT ALL POWER TO THIS UNIT.

SEE NAMEPLATE FOR  
 PROPER VOLTAGE REQUIREMENTS  
 AND MAXIMUM FUSE SIZE

# CME2006R Service Parts

## Three Phase Schematic Diagram

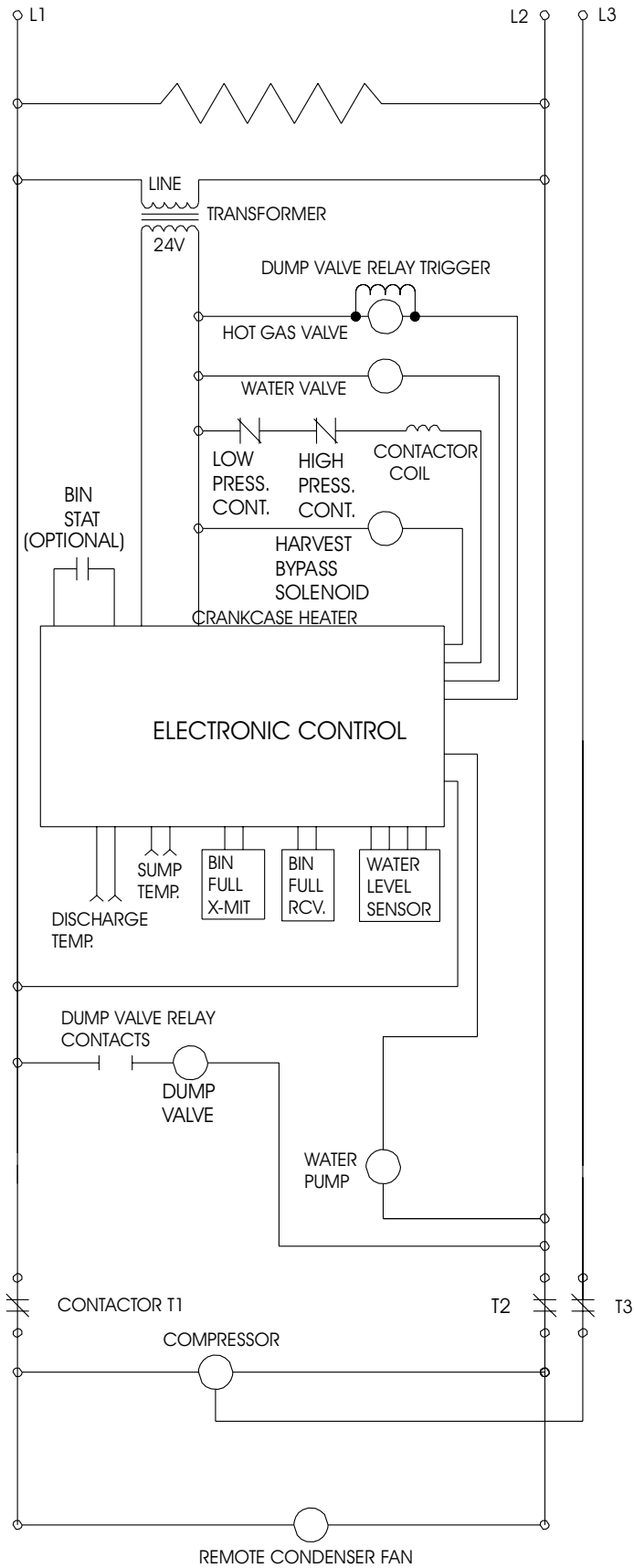

---

# SERVICE BULLETIN

---

**Subject: Controller Cover**

Affects all versions of models: CME1356, CME1656, CME1856 and CME2006

The above models are now manufactured with a sheet metal cover over the top of the controller.

Service controllers also are now shipped with a cover that should be applied to these models whenever replacing the controller if the machine does not already have a cover installed.

Whenever cleaning or servicing any unit, check to see whether it has a cover over the controller like the one shown below. If it does not, Scotsman recommends installing a cover. A separate part is now available for this purpose. Its part number is **A37480-021**. It mounts over the top end of the controller and is secured by two sheet metal screws. Use the cover as a template and drill two 1/8" holes for the two screws.



*Controller Cover*



*Cover Installed on Unit*

Scotsman is shipping a supply of covers to all Scotsman Distributors and listed service agencies. A supply of covers should be carried by each service person on service calls so a cover may be installed on the unit being cleaned or serviced if one is not already in place. Additional covers may be obtained free of charge from Scotsman, through the local Scotsman Distributor, as needed.