

Introduction

To the owner or user: This service manual is intended to provide you, and the maintenance or service technician, with the information needed to install, start up, clean, maintain and repair this product.

The refrigeration system uses HP62 as the refrigerant. HP62 models use polyolester refrigerant oil.

Information on HP62 is located on page 22.

The CME500 is an ice machine that produces cubed ice on 4 vertical cube freezing surfaces. The ice falls as vertical strips of cubes into the ice storage bin where they break up into individual cubes. The CME500 automatically maintains the level of ice by turning on when the ice level falls, and switches off when the bin is full.

Table of Contents

Specifications page 2

Limitations page 3

Installation page 4

Plumbing page 6

Electrical page 7

Final Check List page 8

Component Location page 9

Initial Start Up page 10

Electrical Sequence page 11

Cleaning page 12

Water/ Refrigeration Schematic page 15

Technical Characteristics page 17

Service Diagnosis page 18

Removal and Replacement page 20

Parts lists and wiring diagrams are located in the center of this manual, printed on yellow paper.

Note the warning symbol where it appears in this manual.

It is an alert for important safety information on a hazard that might cause serious injury.



Keep this manual for future reference.

This manual was printed on recycled paper.

CME500

Specifications

Information regarding Model Number, Serial Number, Ampacity and Maximum Fuse Size are located on the nameplate of the ice machine. The model number, serial number and refrigerant charge are also listed on the serial number plate just behind the front panel.

If recharging, always use the charge listed on the ice machine.

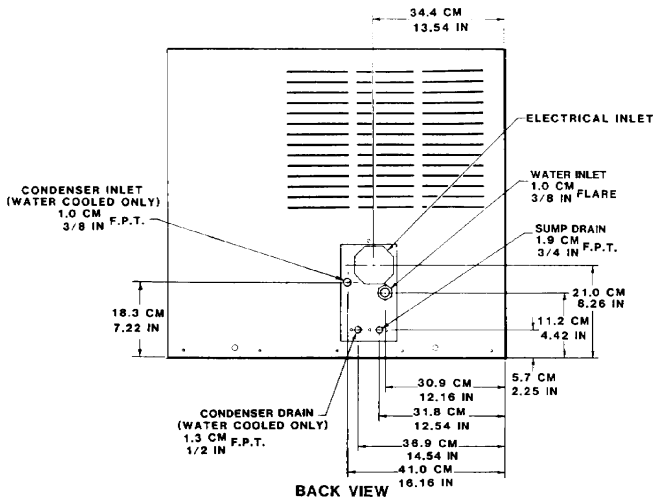
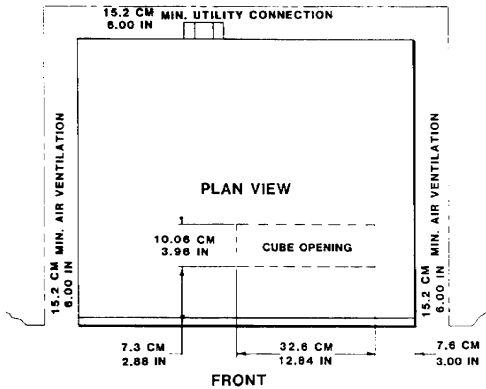
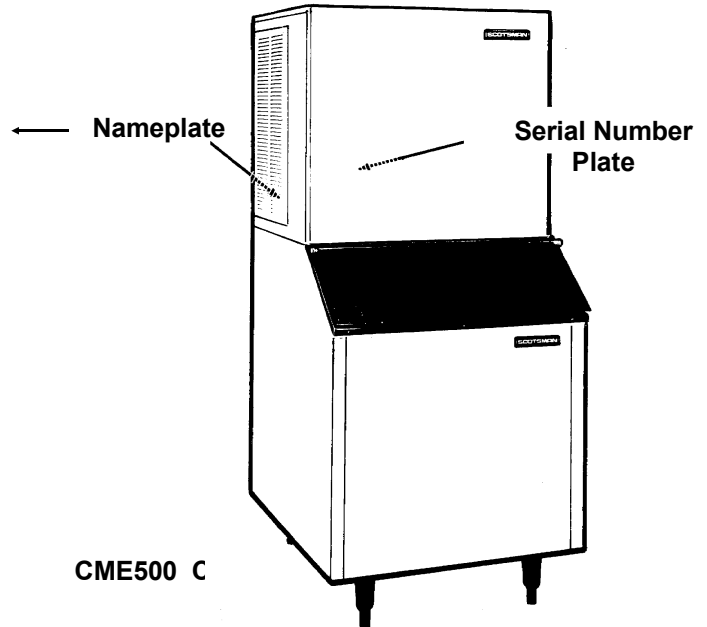
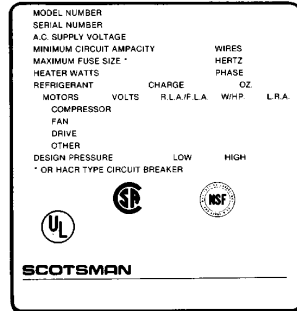

The CME500 will stack onto a variety of ice storage bins, see sales literature for proper ice storage bin. Examples of bins this machine will fit are:

- *BH550
- *HTB500, HTB350, HTB250
- BH800 (with bin top KBT23)
- BH900 (with bin top KBT22)
- BH1360

It will also fit these Scotsman Dispensers:

- CD200
- IS150 (with KADCM1)
- RS150 (with KADCM1)

* These smaller bins are recommended.

There is an optional stainless steel panel kit, SPKCMD-1, for this machine.

Specifications:

Model Number	Dimensions W" x D" x H"	Condenser Type	Basic Electrical	Minimum Circuit Ampacity	Maximum Fuse Size (or HACR circuit breakers)	Refrigerant Charge. HP-62 (R-404a)
CME500AE-1A	30 x 24 x 27	Air	115/60/1	19	20	32 ounces
CME500WE-1A	30 x 24 x 27	Water	115/60/1	19	20	20 ounces

For The Installer: Environmental Limitations

The ice machine must be installed indoors in a controlled environment.

	Minimum	Maximum
Air Temp	50 ⁰ F.	100 ⁰ F.
Water Temp	40 ⁰ F.	100 ⁰ F.
Water Pressure	20 PSI	80 PSI
Voltage	103.5	126.5

Operating the ice machine outside of the above limitations, or outdoors, is potentially damaging to the machine, and it is misuse of the machine. This may void the warranty.

Scotsman Ice Systems are designed and manufactured with the highest regard for safety and performance. They meet or exceed the standards of UL, NSF, and CSA.

Scotsman assumes no liability or responsibility of any kind for products manufactured by Scotsman that have been altered in any way, including the use of any part and/or other components not specifically approved by Scotsman.

Scotsman reserves the right to make design changes and/or improvements at any time.

Specifications and design are subject to change without notice.

Airflow on air cooled models is:

- Intake through the right side grill.
- Exhaust through the left side grill.

Do not install where this air flow is obstructed. A clearance of 6 inches is required at the back and sides.

CME500

Installation

Water

The water supply for this ice machine has been in contact with many materials since it fell from the sky as rain. All rain is slightly acidic, and tends to dissolve the materials it comes in contact with. During water's journey to the ice machine, it has flowed over and through the ground, been picked up by a municipal or private pump, forced through a series of pipes of differing construction and may have been treated by the municipality providing the water.

The water supplied to this ice machine will then contain a variety of substances that will likely show up as solids during the ice making process. These solids are similar to those found when water is boiled out of a saucepan. Only the water boils away, and the minerals that were in the water solidify in the pan. During ice making only the water is frozen into ice, the minerals stay behind in the reservoir. This machine pumps out the water in the reservoir every cycle to minimize the amount of minerals in the water system, but after time the minerals will appear and have to be dissolved by ice machine cleaner, then flushed away during the cleaning process.

An ice machine is a food manufacturing plant; it takes a raw material, in this case water, and transforms it into a food product, ice. The purity of the water is very important in obtaining pure ice and in maximizing product life.

The water to the ice machine should be filtered. Water filters vary greatly in ability and function. Install one that filters out suspended solids to a dimension of 5 microns or less. The finer the filter the better, but finer filters may plug-up sooner than course ones. It may be necessary to add a course filter ahead of the fine filter to prolong filter life.

Have the water tested. Acidic water or alkaline water will both cause corrosion. Dissolved solids cannot be filtered out. Check with a water treatment specialist regarding testing, treatment and filters.

Air cooled models blow air in and out through the grills at the sides (in the right and out the left). Space is required for air flow at the sides and utility connections at the back.

The ice machine is not designed for outdoor use. It must be installed indoors, in a controlled environment. The air and water temperatures must not exceed rated limits.

Pre-installation:

1. Inspect the place where the ice machine is to be installed. Check for:

- space for the cabinet,
- water supply,
- drain availability
- and electrical power supply.

No extension cords are allowed. The building drain inlet must be lower than the drain outlet of the ice bin. The water supply must have a hand shut off valve accessible when the unit is installed.

Installation

Assembly:

1. Attach the legs, or optional casters, onto the ice storage bin. Units that are stacked should only use legs, not casters.
2. Place the ice machine onto the storage bin.
3. Line up the ice machine, check that there is a good seal between the ice machine and the storage bin.
4. If on a Scotsman bin, attach the ice machine to the bin using the straps and bolts shipped with the ice machine. If on another brand bin, follow the directions included with that bin.

Bin Thermostat Installation:

1. Remove rubber cap from the end of the thermostat bracket.
2. Attach the bin thermostat bracket to the bottom of the ice machine using the thumb screws provided. There are pre-drilled and tapped holes located just behind the cube drop area. The end of the bin thermostat bracket with the plastic tubing on it will fit into the hole in the base of the machine.
3. Locate and uncoil a portion of the bin thermostat capillary tube. Route the end of the capillary tube into and through the bin thermostat bracket tube. It should be inserted the full length of the tube, but not past the end.

Stacking:

This machine will stack onto any CM250, CME250, CM450, CM500, CME500, CM650 or CME650 with the same cabinet depth (24").

1. Remove and discard the top panel from the lower unit.
2. Carefully lift the uncrated top unit onto the bottom unit. Use of a mechanical lift is recommended for this step.
3. Align the two ice maker cabinets.
4. Secure the top unit to the bottom one with the hardware and straps shipped with the upper machine.
5. Locate and uncoil all of the bin thermostat capillary tube.
6. Route the bin thermostat capillary tube from the upper unit, through the hole in the back of the reservoir, through the lower unit and into the bin thermostat bracket. Discard upper unit bracket.

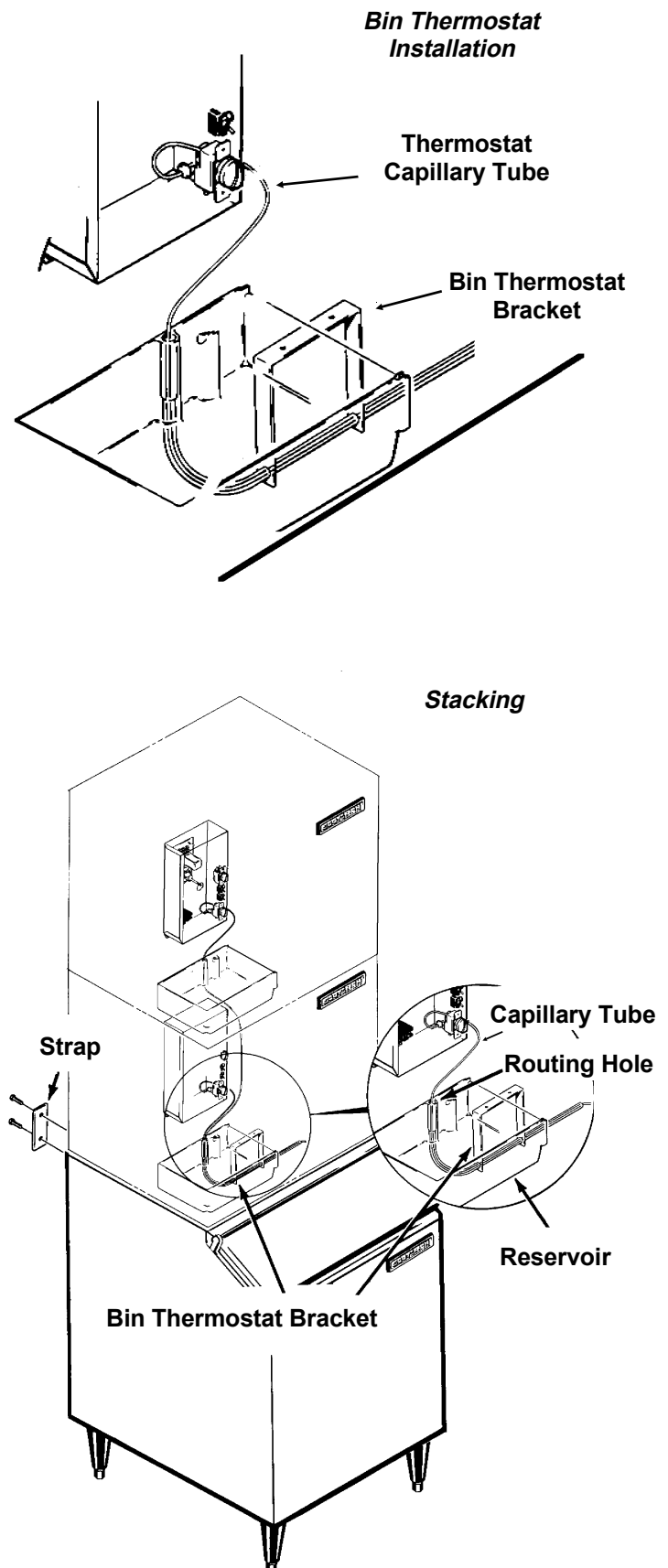

CME500

Installation

For The Plumber

1. Connect cold potable water to the 3/8" male flare at the back of the cabinet. A water filter is recommended. Flush the water line prior to connecting to the ice machine.

If water cooled, connect a separate water inlet line to the water cooled condenser inlet fitting. It should also have a hand shut off valve.

A loop of copper tubing may be used between the ice machine and the water supply. This will allow the ice machine to be pulled out from its installed location without disconnecting the water line. No back-flow preventer should be needed in the inlet potable water line because provision for that is incorporated in this N.S.F. listed product (the tube from the inlet water valve has an air break in it, is above the reservoir wall and cannot siphon).

2. Connect a drain tube to each drain. The drain tubes from these connections must be run separately. There are two connections, one is the bin drain and the other is the reservoir drain. The reservoir drain is a 3/4" F.P.T. brass fitting.

Drain tube material must be rigid and meet local code.

Traps in the bin drain line without vents ahead of them will cause poor draining.

The bin drain must be vented if there is a long horizontal run (5' or more). The reservoir drain must be vented and not connected to the bin drain. All drains are gravity, and must have a minimum fall of 1/4" per foot of horizontal run. The water cooled condenser drain is not vented, and is routed separately.

Maintain the air gap required by local code between the end of the drain tubes and the building drain receptacle.

Note: Drain tubing should be insulated to prevent condensation from forming on the tubing.

CONFORM TO ALL LOCAL CODES

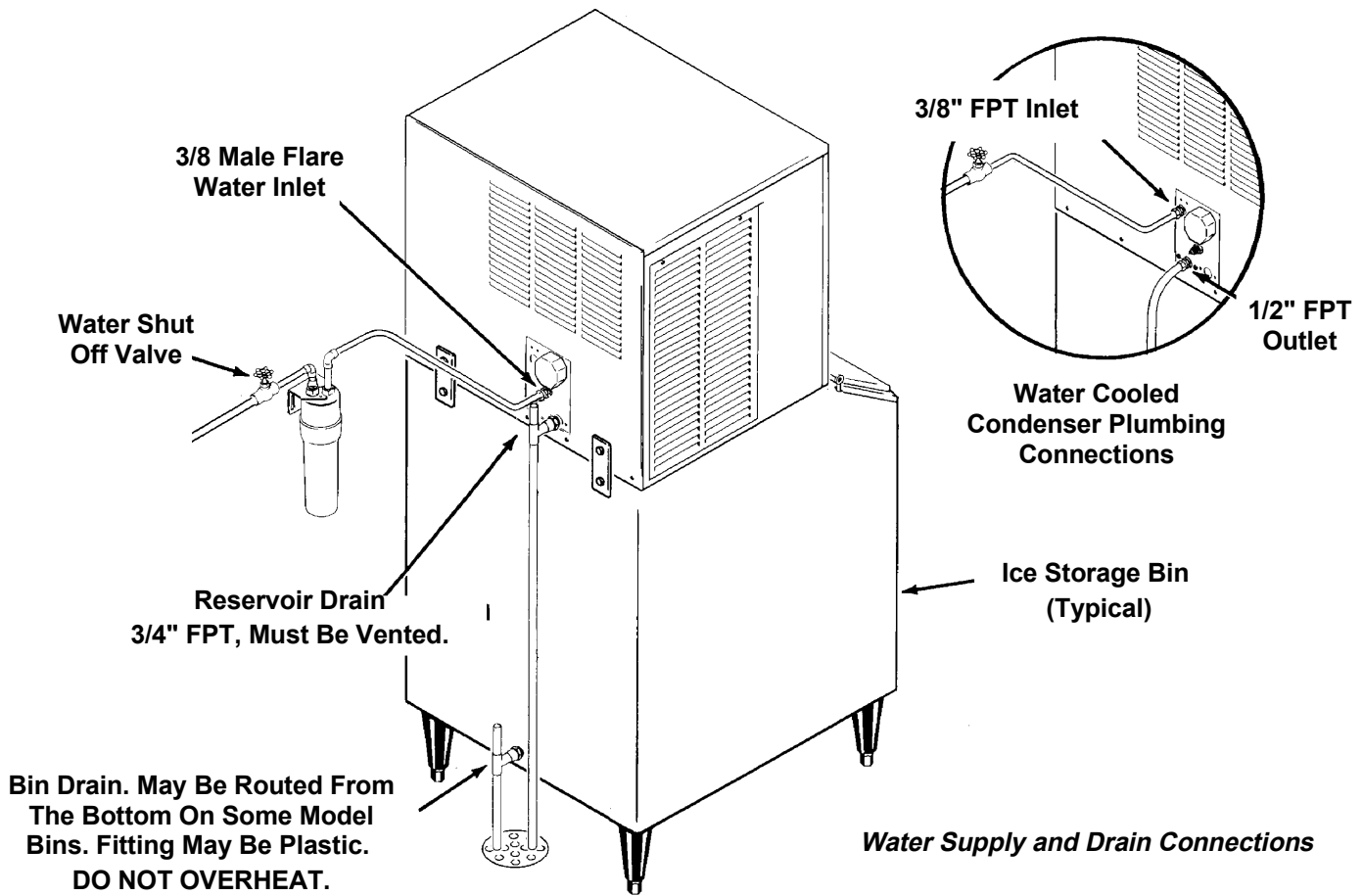

Installation

For The Electrician

This unit must be on a separate 115 volt AC 60 cycle single phase power supply. The maximum fuse size for this circuit is listed on the nameplate, and per the nameplate use fuses, or HACR circuit breakers.

Electrical connections are made at the rear of the ice maker, inside the junction box.

Recommendation: If using wire nuts, cut off the "tinned" ends of the wires and strip off 1/2" of insulation from the end of the wires so there is a copper to copper connection.

Follow All Local Codes - This Unit Must Be Grounded. Usually a licensed electrician will be required to connect the electrical service.

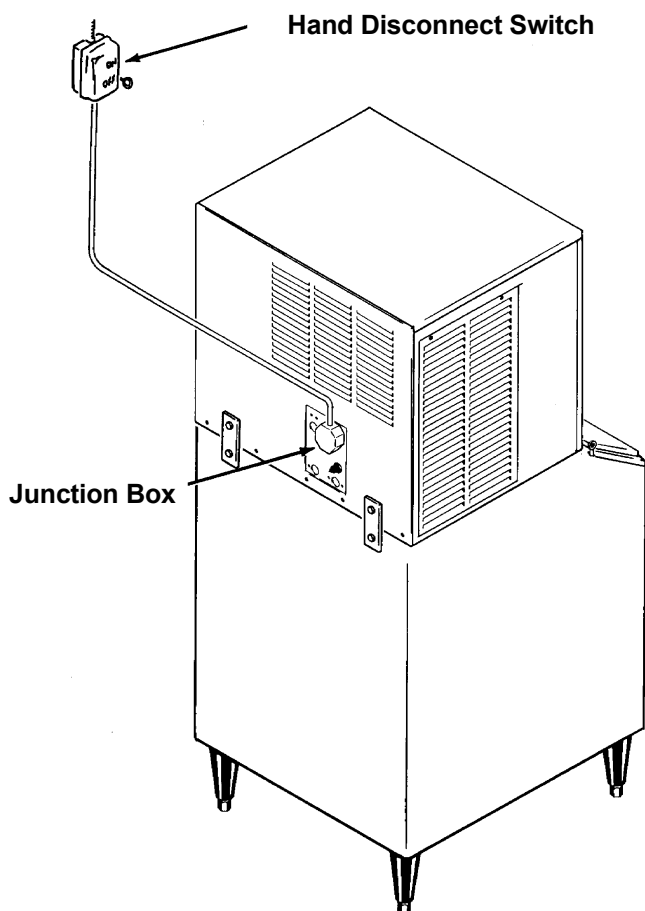

CME500

After Utility Connections

1. Level the cabinet, use the leg levelers on the end of the legs to adjust the cabinet height. (Legs should have been installed when the bin was unpacked).
2. Wash out the bin. If desired, the interior of the bin could be sanitized.

Final Check List

1. Is the ice maker cabinet in a room where ambient temperatures are within the minimum and maximum temperatures specified?
2. Has the water supply been connected?
3. Is the water pressure adequate?
4. Have the water connections been checked for water leaks?
5. Have the drain connections been made?
6. Have the drain connections been checked for leaks?
7. Is the cabinet level?
8. Is the ice machine connected to a 115 volt electrical power supply and is the ice machine the only load on that circuit?
9. Has all of the shipping material been removed from the inside of the cabinet?
10. Has the bin thermostat bracket been attached to the bottom of the ice machine, and the capillary tube routed thru the bracket?
11. Has the bin and cabinet been wiped clean and sanitized?
12. Has the Customer Evaluation & Warranty Registration form been properly filled out? Check for correct model and serial numbers from the nameplate, then mail the completed form to Scotsman.
13. Has the owner/user been given the name and telephone number of the authorized Scotsman Service Agency serving that location?

Component Location

The ice machine is designed for front service. Many components are serviceable from the front without removing the side panels.

Behind the front panel:

- Water pump
- Inlet water valve
- Reservoir
- Evaporators
- Water distributor
- Control box with cube size control adjustment
- ON/OFF switch
- Compressor switch

Inside the control box is control system for the ice machine.

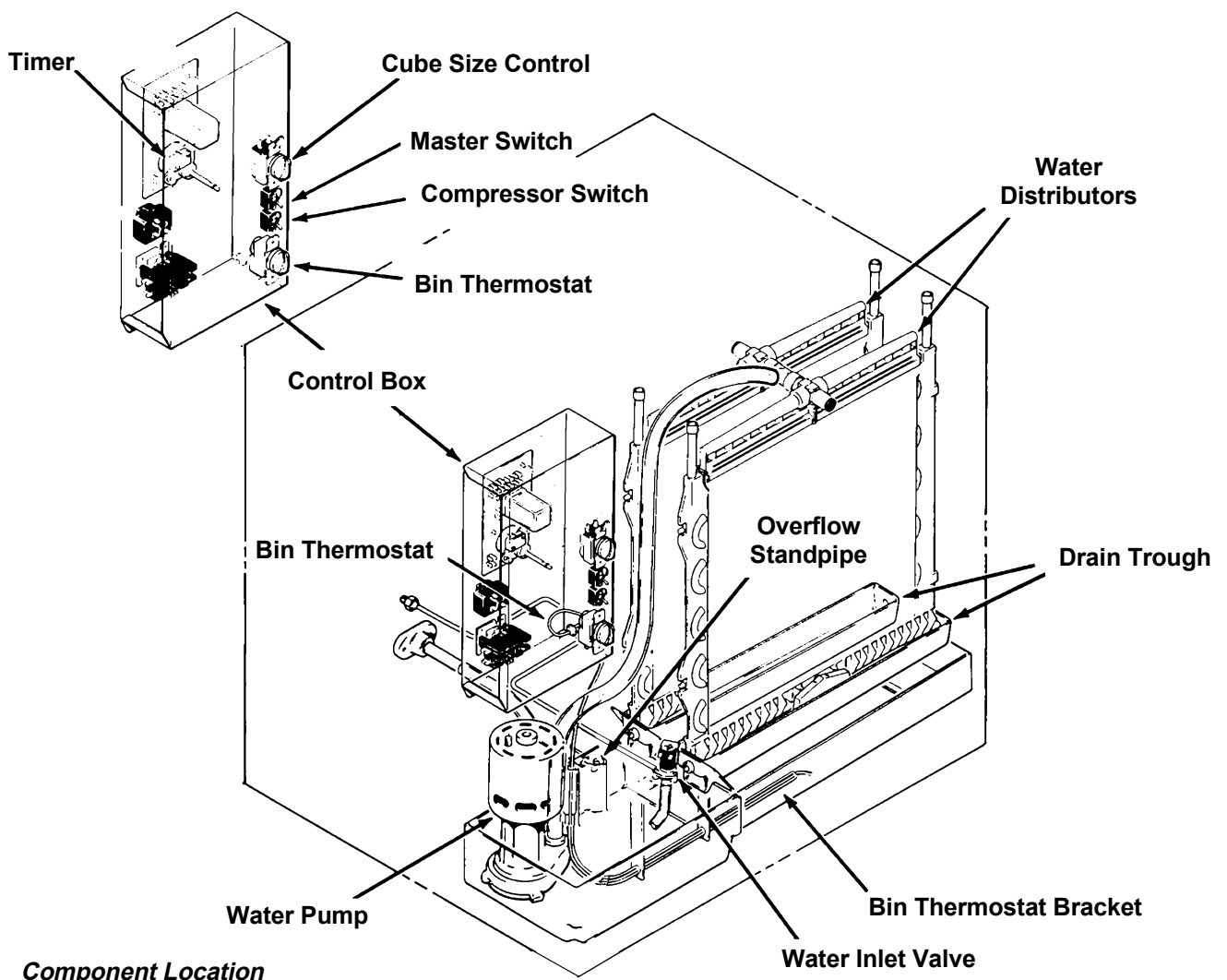

CME500

Initial Start Up

After the final check list has been gone through, the ice machine may be started up.

1. Open the water shut off valve.
2. Switch on the electrical power.
2. Remove the front panel.
4. Remove the control box cover.

5. Locate the timer and rotate the cam clockwise until the timer is in the Harvest Position.

Control Box

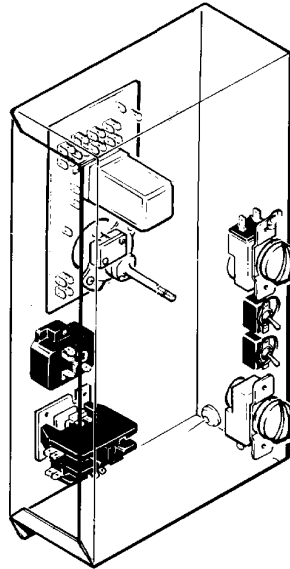

Cube Size Control Knob

Bin Thermostat

6. Switch the compressor switch to OFF.

3. Locate the ON/OFF switch, switch it to ON.

4. The inlet water valve will open, and water will flow into the reservoir. The water pump will begin to pump water over the evaporators.

5. Allow the reservoir to fill.

6. Switch the compressor switch to ON.

7. On air cooled models the fan motor will begin to turn, and warm air will be discharged from the left side of the ice machine. On water cooled models warm water will begin to flow from the condenser drain.

Note: To optimize the balance between ice production and water use, the water cooled discharge pressure **must be 245 P.S.I.G.** Check discharge pressure and adjust water regulating valve to obtain 245 P.S.I.G. discharge pressure.

8. The water temperature in the reservoir will soon be 32°F., and ice should begin to form on the evaporators. Note: In some cases some slush will form in the reservoir. This is temporary and normal.

9. Allow the ice machine to operate for about 22 minutes. The ice should be fully formed and should be harvested within a few minutes.

10. After harvest, check the ice cube size. If needed, adjust the cube size by rotating the adjustment knob of the cube size control. Rotate it 1/8 turn clockwise to make the cubes thicker, and rotate it 1/8 turn counterclockwise to make the cubes thinner.

The machine is designed to only harvest cubes that are the correct thickness.

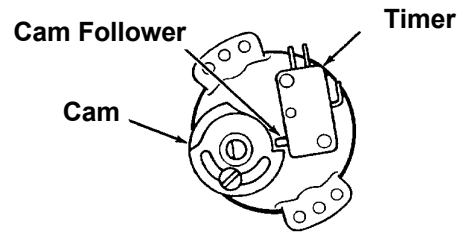

Timer Shown In Harvest Position

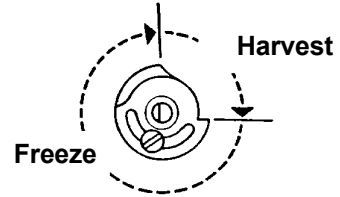

Cubes Too Thick

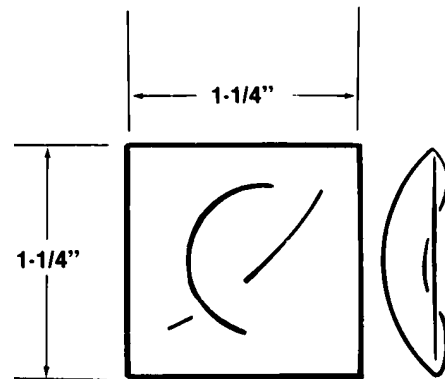
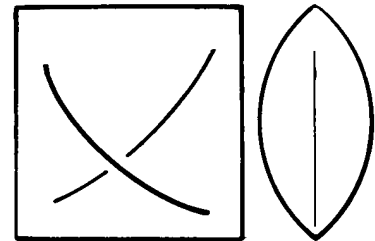

Correct Size & Shape

At this size, the typical batch weight will be 5.5 lb. per cycle.

Cubes Too Thin

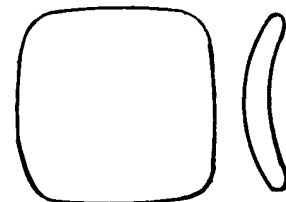

Initial Start Up

11. **Check harvest time. The machine will have to harvest all of the cubes before it goes back into the freeze cycle.**

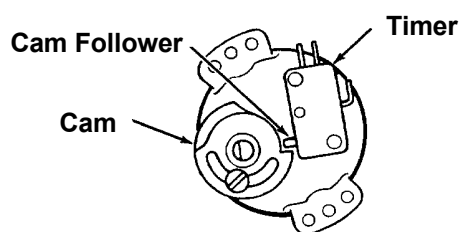

Timer Shown In Harvest Position

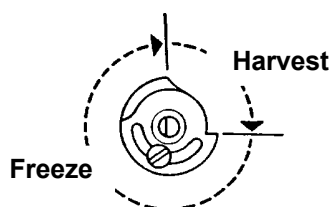

Increase the Harvest Time if there is less than 15 seconds of harvest time after the last cube has fallen into the bin. The machine ships set at 2 $\frac{2}{3}$ minutes of harvest time.

Decrease the Harvest Time if there is much more than 15 seconds of harvest time after the last cube has fallen into the bin. Note: Harvest time is dependent upon the water and air temperatures at the ice machine. Colder air and water will result in faster ice making, but longer harvest cycles. Do NOT adjust harvest time too short, as this will cause a freeze up of the evaporators.

To Adjust Harvest Time:

1. Disconnect electrical power.
 2. Locate time cam in control box.
 3. Loosen set screw holding the two halves of the cam together, and rotate the front half to increase or decrease the harvest portion of the cam (low part).
 4. Re-tighten the set screw.
 5. Reconnect power and check cube size of the next cycle, as it may require adjustment after the harvest time has been set.
12. Check operation of the bin control circuit by holding ice on the bin control tube in the bin. This simulates bin full and the ice machine should switch itself off at the end of a harvest cycle.
13. Replace all the panels. The ice machine is now ready for automatic operation..

Electrical Sequence:

This describes the sequence through a complete cycle.

Freeze Cycle:

During the first part of the freeze cycle, the ice machine compressor, fan motor if air cooled, and water pump are operating. The relay in the middle of the circuit board is energized.

Timed Freeze:

Cube size control closes, connecting power to the timer motor, and after a few (4.5-5.5) minutes this timer opens the circuit to the relay on the circuit board. This starts the harvest cycle.

Harvest:

In the harvest cycle, the water pump and compressor stay operating, and these two valves are energized:

- Hot gas valve
- Inlet water valve

The unit stays in the harvest cycle until the timer has turned the cam which has pushed the timer micro switch button IN. If the bin thermostat is OPEN, the ice machine will stop. If the bin thermostat is CLOSED, the relay will energize, and the unit will make another batch of cubes.

CME500

Maintenance and Cleaning

Cleaning Schedule:

- Scrub the outside of the cabinet once a week with soap and water.
- Wash off the bin door, frame and gaskets daily.
- Sanitize the bin interior once a month.
- Clean the water system and air cooled condenser a minimum of twice per year. If in an area of high mineral concentration in the water supply, clean water system 4 times a year.

This ice machine will perform at its best when kept clean. There are two areas to keep clean: The water system including the water reservoir, distributor tube and evaporator surface; and the air cooled condenser filter and the condenser itself.

Inlet Water Valve Screens

If a restriction of incoming water is suspected, the screen on the inlet side of the water valve should be inspected & cleaned. Some models also have a strainer in the water line; the strainer screen should also be inspected for restricting minerals.

Inlet Water Valve

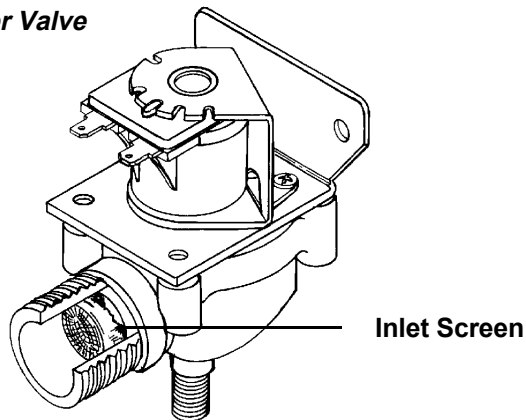

Air Filter (air cooled only):

1. Remove the grill on the right side of the unit.
2. Remove the filter pad from in front of the condenser.
3. Wash the surface of the filter off with cold water, or, if torn or so dirty it can't be cleaned, replace with a new filter.
4. Return the filter to its installed position.
5. Replace the grill. Do not operate the unit without the filter in place.

Note: If the unit has been operated without the filter in place, the fins of the condenser will become fouled with dirt, and must be cleaned. A vacuum cleaner with a soft brush attachment will extract most loose dust stuck to the surface of the condenser fins. If there is any doubt about dirt inside the fins of the condenser, the cabinet should be removed and a qualified service agent should clean the condenser.

Water cooled units:

The water cooled condenser may, over time and under certain water conditions, become internally restricted by minerals. These will have to be dissolved by acid or the condenser replaced. Only a qualified service agent should attempt this type of service.

Cleaning: Ice Storage Bin

The interior liner of the bin is in contact with a **food** product: **ice**. The storage bin must be **cleaned** regularly to maintain a **sanitary** environment.

Every 30 days, the liner should be sanitized with a commercial ice machine sanitizer, according to the directions of the sanitizer, or with a solution of household bleach and water:

1. Mix the bleach and water using the ratio of one ounce of bleach to two gallons of water.
2. Wipe all interior surfaces of the ice storage bin with the bleach and water.
3. Allow to air dry.

Note: If the ice baffle was removed from the bin during cleaning it must be reinstalled in the bin.

To Remove Scale:

1. Mix a cleaning solution of 4 ounces of Scotsman Ice Machine Cleaner to 4 pints of hot (95⁰F.-110⁰F.) water.
2. Using rubber gloves, dip a nylon scouring pad into the cleaning solution and scrub the scale off the liner.
3. After the scale has been removed, rinse all surfaces inside the bin with clean, potable water.

Stainless Steel Components Inside Bin

The stainless steel parts in the bin also require periodic cleaning. Chemicals in the water supply, such as chlorine, cause brown stains to appear on the surface of the stainless steel parts.

1. General Cleaning - staining is usually removed by washing the parts with ordinary cleaning powder such as Bon-Ami or Copper-Glo and water. After cleaning, rinse with clear water.
2. Water treatment. The chlorine enters the machine from the municipal water supply. It can be removed from the water supply by using a charcoal or activated carbon water filter to treat the water to the ice machine. If staining is severe, filters of this type are recommended.

Exterior Cabinet Cleaning:

The exterior cabinet may be cleaned by scrubbing with soap and water. Do not use cleaners containing petroleum products.

A nylon type brush may be used to scrub stubborn deposits.

CME500

Cleaning: Ice maker

1. Remove front panel.
2. Remove control box cover, and turn the timer cam clockwise until the unit is in a harvest cycle. At the end of the harvest cycle switch the master and compressor switches to OFF. Replace the control box cover.
3. Remove all ice from the bin.
4. Remove 4 thumbscrews and the evaporator cover.
5. Remove water pump discharge hose from evaporator water inlet, direct hose into bin or bucket and switch the master switch ON until reservoir is empty of water. Replace hose on inlet.
6. Replace evaporator cover.

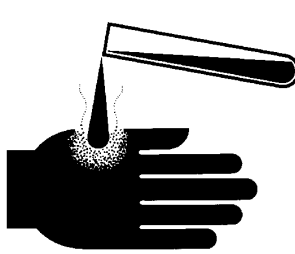
<p>Scotsman Ice Machine Cleaner contains acids. These compounds may cause burns.</p> <p>If swallowed, DO NOT induce vomiting. Give large amounts of water or milk. Call Physician immediately. In case of external contact, flush with water.</p> <p>KEEP OUT OF THE REACH OF CHILDREN.</p>	<p>WARNING</p> 
---	--

7. Mix 8 ounces of Scotsman Ice Machine Cleaner with 1 gallon of warm (95°F. - 115°F.) water and pour into the reservoir until full.
8. Switch the master switch ON, and operate the unit for 20 minutes, then switch the unit OFF.
- 9 Repeat steps 4 and 5.
10. Wash the plastic and stainless liners of the freezer section with a solution of household bleach (1 ounce of bleach to 2 gallons of water) and warm (95°F. - 115°F.) water. Allow to air dry.
11. Pour 1/2 gallon of the solution mixed in step 10 into the reservoir. Replace the evaporator cover.
12. Switch the master switch back ON, operate the unit for 5 minutes. Switch unit OFF.
13. Repeat steps 4, 5 and 6.
14. Pour about 1/2 gallon of clean potable water into the reservoir, and switch the master switch ON. After 5 minutes switch the master switch OFF and repeat steps 4, 5 and 6.

15. Switch master and compressor switches ON.
16. Replace the front panel
17. Discard the next batch of cubes to make sure all of the acid & sanitizer is gone.

//////////////////////////////////**CAUTION**//////////////////////////////////

DO NOT use ice cubes produced from the cleaning or sanitizing solutions. Be sure none remain in the bin.

//////////////////////////////////

18. Pour hot water into the storage bin to melt the cubes and also clean out the bin drain.
19. Wash the bin liner with a solution of household bleach (1 ounce of bleach to 2 gallons of water) and warm (95°F. - 115°F.)water. Allow to air dry.
20. The unit will now continue automatic operation.

Water Distributor:

Note: The water distributor may need to be cleaned separately.

1. Remove evaporator cover.
2. Remove water distributor assembly by pushing the assembly to the right until the left end clears the retaining tab.

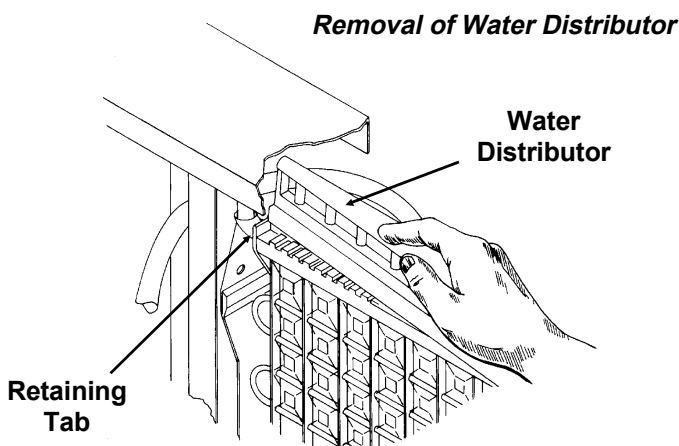

3. Lift up the left end of the water distributor assembly and pull the assembly to the left.
4. Un-snap the water distributors from the "T", and inspect for mineral deposits. Clean as required.
5. Reverse above steps to reassemble. Be certain that water distributors are in place and secure.

Scale that may form on the plastic liner can be removed by scrubbing the surface with a mixture of Scotsman Ice Machine Cleaner and hot water. Remove any scale prior to cleaning.

Refrigeration Schematic:

Freeze Cycle:

From the compressor, hot discharge gas is pumped to the condenser, either air or water cooled.

At the condenser, heat from the refrigerant flows into the cooling medium, either air or water, and the refrigerant condenses into a liquid. From the condenser the liquid refrigerant flows through the liquid line to the metering device - a thermostatic expansion valve.

At the expansion valve, liquid refrigerant passes from a high pressure zone to one of relatively low pressure, and in the low pressure zone it evaporates. The low pressure zone where the refrigerant evaporates is the evaporator. When the refrigerant evaporates, it absorbs heat from the metal parts of the evaporator and the water flowing over it.

From the evaporator, the refrigerant flows back to the compressor through the suction line.

Water Schematic:

Water flows into the ice machine from its inlet connection at the back of the cabinet, through the inlet water valve and into the reservoir. The water in the reservoir is pumped up and through the water distributor tube at the top of the evaporators. From there, the water flows over both sides of the evaporators and back into the reservoir.

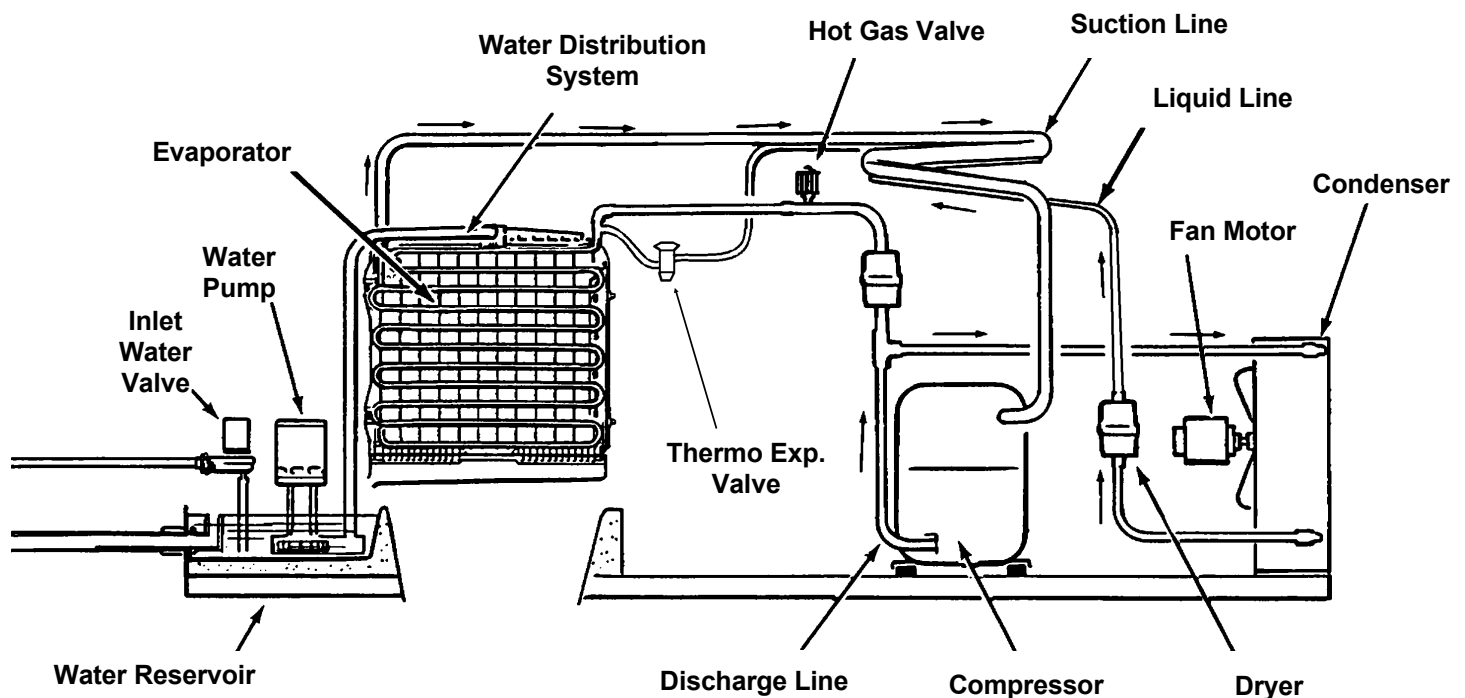

Refrigeration Schematic

CME500

Harvest Cycle:

During the harvest cycle, the refrigerant flows from the compressor, through the discharge line to a branch in the line containing the Hot Gas Valve. This valve is Open during the harvest cycle, allowing the hot discharge gas to bypass the condenser and enter the evaporator at its inlet.

The hot discharge gases warm up the evaporator enough to allow the surface of the ice frozen to the evaporator to melt. The remaining ice will then fall off into the bin.

During the Harvest Cycle, the inlet water valve opens, filling the reservoir and allowing the reservoir to overflow the drain.

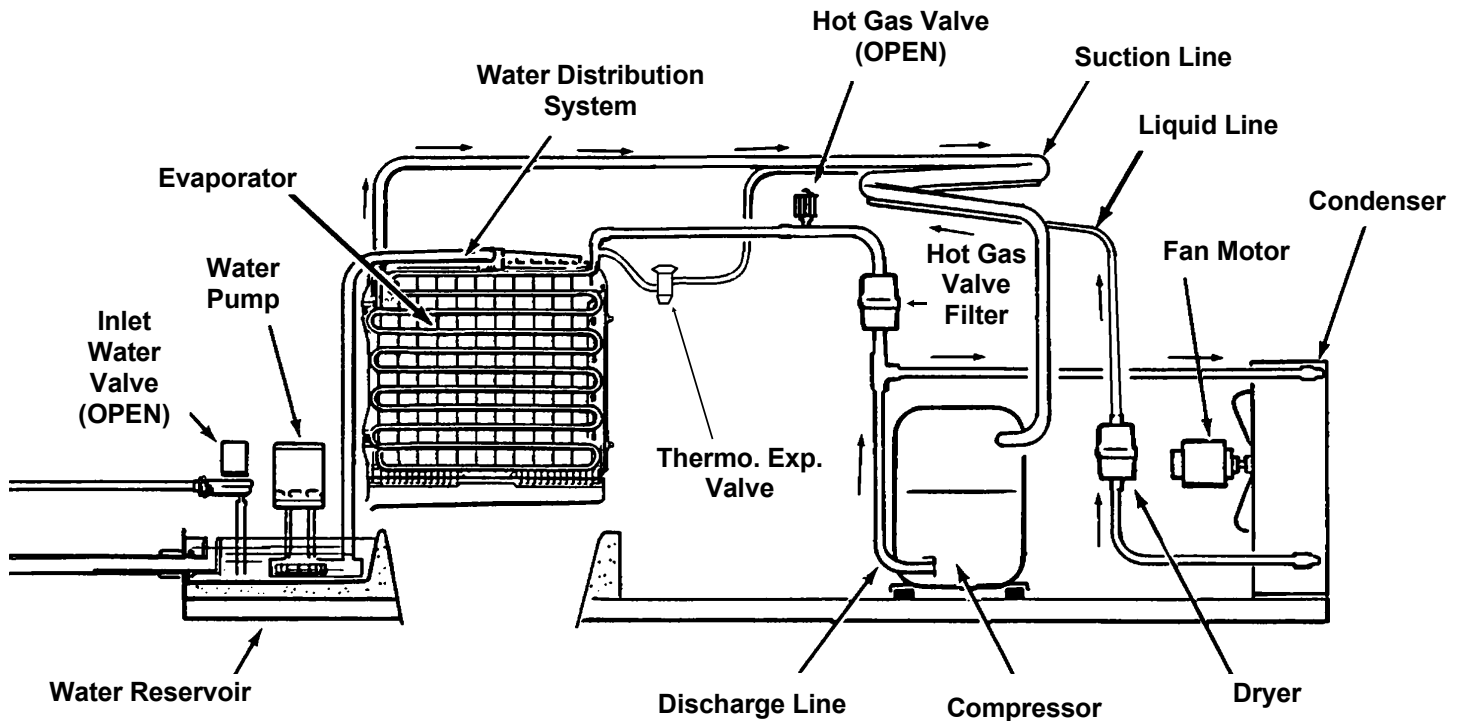

Refrigeration Schematic

Technical Characteristics

Typical Cycle Time

- 24 minutes @ 90°F. air and 70°F. water
- 19 minutes @ 70°F. air and 50°F. water

Typical Harvest Ice Weight

- 5.5 - 6 pounds.

Typical Low Side Pressure Just Before Harvest

- Air cooled = 40 PSIG; Water cooled = 35 PSIG

Typical Freeze Cycle Air Cooled Discharge Pressure

- 275 - 290 PSIG @ 90°F. air and 70°F. water

Refrigerant Charge:

- Air cooled = 32 ounces R-404A
- Water cooled = 20 ounces R-404A

Harvest Time

- Pre-set at 2 and $\frac{2}{3}$ minutes. Adjustable to match field requirements.

Typical Low Side Pressure, in harvest:

- Air cooled = 105 PSIG; Water cooled = 85 PSIG

Typical Peak Discharge Pressure, in harvest:

- 200-210 PSIG

Hi Pressure Cut Out Point:

- 450 PSIG, air cooled; 400 PSIG, water cooled

Fan Pressure Switch

- 240 PSIG C.I.
- 190 PSIG C.O.

Hi Temperature Cut Out Point:

- 140°F. (at hot gas valve)

Typical Compressor Amp Draw:

- 10-12 during the freeze cycle and 12-15 during the harvest cycle (115 v).

Compressor:

- Copeland: RS55C1E-PAA-213

Water Inlet Valve Flow Rate:

- .75 g.p.m.

Cube Size Thermostat:

- Adjustable Cut In as needed to obtain correct cube size, C.I. range between 42°F. and 5°F

Bin Thermostat

- Adjustable; C.I. range between 38.5°F. and 43.5°F, C.O. range between 33.5 °F. and 38.5 °F

Thermostatic Expansion Valve

- Not adjustable

CME500

Service Diagnosis:

SYMPTOM	POSSIBLE CAUSE	PROBABLE FIX
No ice is made, nothing operates	Unit off, due to no power	Restore power
	Unit off, due to master switch in OFF position	Switch master switch to ON
	Unit off, due to bin thermostat open	Check temperature at bin thermostat bracket, if warmer than 40° F., thermostat should be closed. Adjust/replace thermostat.
	Unit off, due to hi pressure cut out open	Reset and check for dirty condenser, hot location, or water interruption (if water cooled).
	Unit off, due to hi temperature cut out open	Hot gas valve leaking thru, replace hot gas valve.
	Unit off, due to circuit board open	Check for short circuit and replace circuit board.
No ice is made	No water due to water turned off.	Reconnect water supply
	No water due to water filter plugged.	Replace water filter
	No water due to inlet water valve screen plugged	Clean out inlet screen
	No water due to strainer screen plugged	Clean out inlet screen
	No water due to Inlet water valve coil open	Replace valve
	No water due to inlet water valve will not open	Replace valve
	Water in reservoir, but no water over evaporators	Water pump does not work, replace pump
	No cooling at evaporator due to compressor switched off	Switch compressor on.
	No cooling at evaporator due to too much heat load because inlet water valve leaks thru	Replace inlet water valve
	No cooling at evaporator due to hot gas valve leaking thru	Replace hot gas valve
	No cooling at evaporator due to fan not turning	Check & replace fan motor or fan control switch
	No cooling at evaporator due to dirty condenser	Clean condenser

Service Diagnosis

SYMPTOM	POSSIBLE CAUSE	PROBABLE FIX
No ice is made	No cooling due to low refrigerant charge	Locate leak, recover remaining refrigerant, replace dryer, evacuate and weigh in nameplate charge.
	Will not harvest due to hot gas valve not opening.	Check for voltage to coil in harvest, if there is voltage check coil, if coil is ok, replace hot gas valve
	No cooling due to compressor not operating	Check compressor for voltage, continuity, and operation. Replace if found to be faulty.
	Will not harvest due to not enough harvest time.	Adjust harvest time longer.
	Will not harvest due to lack of water.	Check water supply & distribution system. Clean water system with Scotsman Ice Machine Cleaner.
Makes ice, but very little	High discharge pressure, due to dirty condenser, faulty fan motor, fan pressure switch, not enough water thru water cooled condenser.	Check for causes of high discharge pressure and correct.
	Inlet water temperatures and room ambient very high	Advise user, suggest additional room cooling.
	Compressor inefficient	Check/replace compressor
Cubes are wrong size/shape	Cube size control not adjusted properly	Adjust cube size control
	Water system is restricted with minerals	Clean water system with Scotsman Ice Machine Cleaner
	Not enough water	Check water supply pressure Check water supply for restrictions
Ice fused together in bin	Ice in bin too long	Advise user to pour water on ice to ease removal
	Too many minerals in water	Suggest water treatment to user.
Water drips on ice	Water distributors loose	Set water distributors in place on top of evaporator.
	Some water is normal.	Advise user.
	Cube size too small	Adjust thicker.
	Water system is dirty	Clean water system with ice machine cleaner.

CME500

Removal and Replacement

Cube Size Control:

Before replacing the cube size control, it should be positively determined that it is at fault.

If it does not open when warm, replace it.

1. Disconnect electrical power.

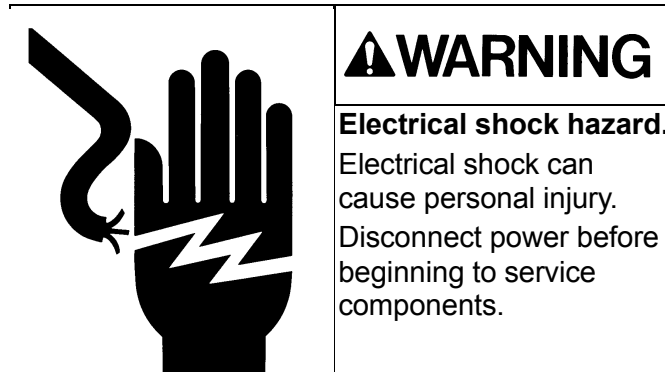

2. Remove the front panel.
3. Remove the control box cover.
4. Locate the cube size control.
5. Remove the two screws holding the control to the control box, and lift the control out.
6. Pull the two wires off the posts of the cube size control.
7. Follow the capillary tube of the cube size control and remove it from the grommet in the back of the control box.
8. Locate bulb on suction line.
9. The end of the cube size control is inserted in a socket attached to the suction line. Pull it out of the socket.
10. Replace the cube size control with the proper part number, following the above steps from 9-1.

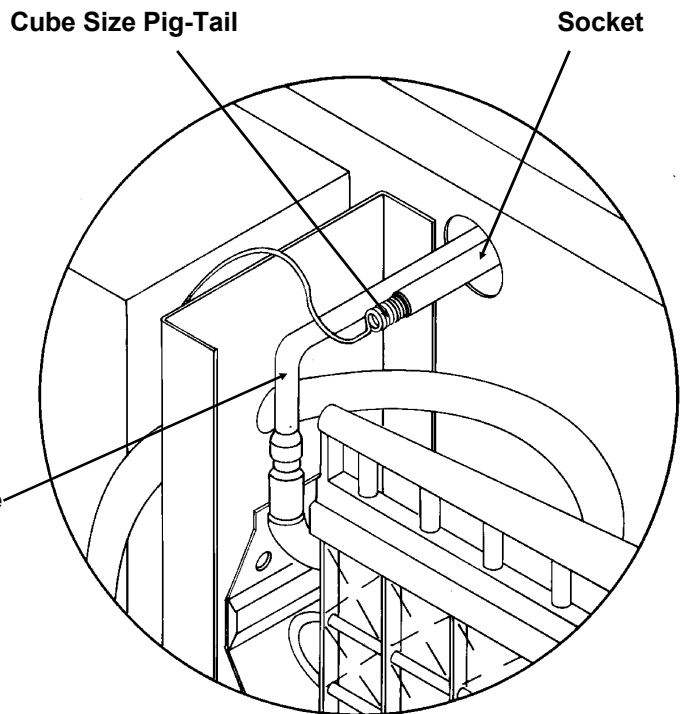

Replacement of Cube Size

Removal and Replacement

Water Pump

The pump provides the force to move the water from the reservoir to the freezing surface. The pump does not need oil, but if it becomes noisy, overheats, or will not pump it should be replaced. Be certain to confirm electrical faults with a voltmeter or ohmmeter before replacing the pump. The pump should be operating whenever the compressor is.

1. Unplug or disconnect the electrical power.

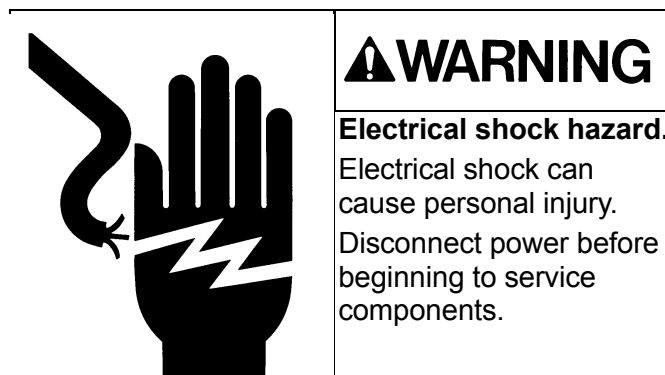

2. Unplug the pump from its connection.
3. Loosen the two fasteners holding the bracket to the wall.
4. Pull discharge hose from pump discharge port.

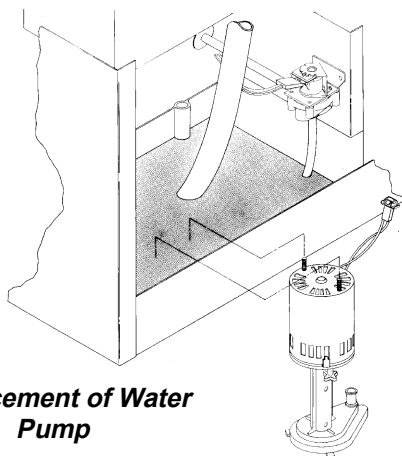

Replacement of Water Pump

5. Remove pump from ice machine.
6. Remove bracket from pump.
7. Reverse above steps to replace.

Inlet Water Valve

The valve water to enter the reservoir during harvest but not during freeze. The valve may plug-up from minerals in the water, and may be cleaned rather than replaced.

1. Shut off the water supply.
2. Unscrew the fitting at the back of the valve, and pull the water inlet tube out of the valve body.
3. Remove the screws holding the valve to the bracket.
4. Unplug the electrical connection from the valve.
5. Remove the valve from the ice machine.
6. Reverse the above steps to reassemble.

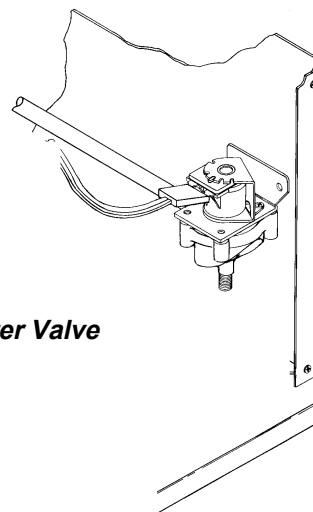

Inlet Water Valve

CME500

REFRIGERATION SYSTEM: HP62 (R-404A) Refrigerant

THIS ICE MACHINE USES HP62 REFRIGERANT AND POLYOLESTER COMPRESSOR OIL

DO NOT USE MINERAL OIL IN THIS REFRIGERATION SYSTEM.

- HP62 is a "Near Azeotrope", and therefore liquid charging is required.
 - ☒ Weigh in as much of the charge (as liquid) as possible into the discharge size.
 - ☒ Install a sight glass between the suction side and the gage manifold. Use the manifold valve to "flash off" the liquid refrigerant before it enters the ice machine. Do this until the proper charge is weighed into the system.
- When the system is serviced, a special liquid line dryer is required (see parts list).
- Polyolester oil absorbs water very easily, and therefore when the system is opened for service, it must be re-sealed as soon as possible (15 minutes maximum).
- Special leak detection equipment is required to locate small refrigerant leaks. Usually a leak detector capable of detecting a Halogenated refrigerant or HFC-134a will work. Check with the leak detector manufacturer if in doubt.
- Do NOT mix with air for leak testing.

Pressure-Temperature Chart for HP62

VAPOR		VAPOR	
TEMP.	PRESSURE	TEMP.	PRESSURE
(DEG F)	(PSIG)	(DEG F)	(PSIG)
-20	17	70	146
-18	18	72	150
-16	20	74	155
-14	21	76	161
-12	23	78	166
-10	24	80	171
-8	26	82	177
-6	28	84	182
-4	29	86	188
-2	31	88	194
0	33	90	200
2	35	92	206
4	37	94	212
6	39	96	219
8	41	98	225
10	43	100	232
12	46	102	239
14	48	104	246
16	50	106	253
18	53	108	260
20	55	110	268
22	58	112	275
24	60	114	283
26	63	116	291
28	66	118	299
30	69	120	307
32	72	122	316
34	75	124	324
36	78	126	333
38	81	128	342
40	85	130	351
42	88	132	360
44	91	134	370
46	95	136	379
48	99	138	389
50	102	140	399
52	106	142	409
54	110	144	420
56	114	146	430
58	118	148	441
60	123	150	452
62	127	152	464
64	132	154	475
66	136	156	487
68	141	158	499

REFRIGERATION SERVICE

General:

- Scotsman recommends that any work on the refrigeration system only be done when it is certain that the system needs repair. **Use conservation minded service procedures:**
- **Refrain from checking refrigeration pressures without reason.** There are many ways to determine the proper operation of a Scotsman ice machine without using refrigerant gauges. Visual inspection of the water system, observation of the ice formation, amp draw, voltage, and other techniques will lead to proper diagnosis. Scotsman also recommends that, at the time of initial start up, gauges not be used.
- Refrigerant should not be added except as a way to determine the proper operation of the product. If the system was low on refrigerant, there is a leak, and it must be found and repaired.
- Refrigerant should not be wasted to the atmosphere.
- This system has a critical charge, it must be recharged with the correct amount of refrigerant as listed on the nameplate of the ice machine, or performance will suffer.
- Anytime the refrigeration system has been opened, the dryer should be replaced. **Note: Only a HFC type dryer should be used.**
- When brazing the tubing connections to the hot gas valve, the component must be protected by heat sink material.
- **If gauges must be used, do not always check the high side pressure.** If the condenser is clean and seems to be operating correctly, it most likely is. The low side pressure is much more important on an ice machine than is the high side.
- If gauges must be used, use very short hoses. Minimal refrigerant discharged into the hoses equals minimal refrigerant discharged into the air.

Recover, reclaim or recycle refrigerant.

The method chosen is up to the service company. There are various mechanical devices that may be used to recycle refrigerant at the field level, however, Scotsman requires that any refrigerant placed into a Scotsman ice machine meet ARI

spec 700-88. Reclaim programs are available through most refrigerant wholesalers.

Access Valves: To use the access valves:

Remove the cap from the stem of the valve, then use a 3/16" allen wrench to check that the valve is closed. The core cap may then be removed.

Close the valve and replace the caps when the

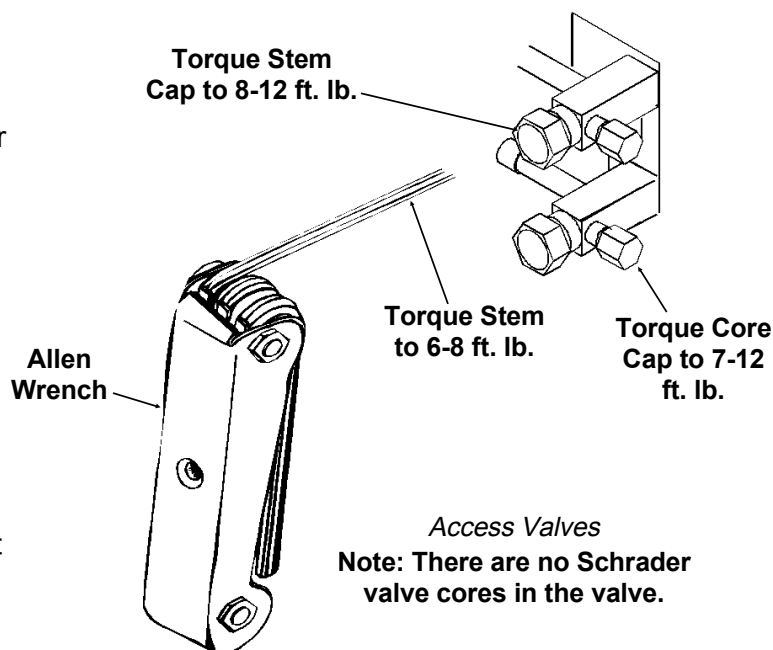

job is finished. The valve must be closed and the caps must be on or the valve will leak.

CME500

Removal and Replacement: Refrigeration System

If the refrigeration system must be serviced, the **quality of service must insure that there will not be a repeat failure**, as repeat failures will cause refrigerant to be discharged into the air by the failure or when the failure is corrected:

- If there has been a compressor burn out, check for acid in the oil. If acid is indicated, extra steps must be taken to clean up the system.
- Never use refrigerant to clean up or flush out a refrigeration system. When system clean-up is required, the use of suction line filter-dryers and liquid line filter-dryers are recommended (they must be compatible with polyolester oil and HFC refrigerant).
- Always replace the dryer when repairing a leak or replacing a refrigeration component.
- Evacuate the system with a good vacuum pump to 200 microns or less. If the triple evacuation method is used, the vacuum should be broken each time with dry nitrogen, not refrigerant. Evacuation must be from both sides of the system.
- Weigh in or measure in the nameplate charge. Recharge into the high side.
- Check for leaks with a high quality, electronic leak detector capable of locating HP62.
- If using recycled refrigerant, it must meet ARI spec 700 or have been cleaned by a machine capable of attaining ARI spec 700-88.

If an ice machine is to be discarded and still contains refrigerant, Scotsman recommends that the refrigerant be recovered, reclaimed, or recycled so that it is not discharged into the air.