

CME506R, CME656R & CME806R Service Parts

This parts list contains the service part numbers for 3 basic Electrical Components Common to All Machines models, plus 4 different electrical configurations. It contains service parts for all series machines. The series differences include:

- A - first production
- B - not used
- C - New front panel and side panels
- D - New top panel and PTCR
- E - New side panels and CME506R expansion valve change
- Inlet water valve
- System controller
- Water sensor
- Discharge line sensor
- Bin controls
- Water level sensor
- Hi pressure cut out

The complete model number will be needed to identify the correct part.

Unique parts include: cabinet, electrical and refrigeration.

Electrical Codes are located at the end of the model number (voltage/hertz/phase):

- -1 is 115/60/1
- -32 is 208-230/60/1
- -3 is 208-230/60/3
- -6 is 250/50/1

Unique Electrical Components

- Compressor and related starting components
- Contactor (single / three phase)
- Fan motor
- Water pump
- Transformer
- Hot gas valve

Table of Contents

Cabinet	page 2
Interior Structure and Controls	page 3
CME506 Refrigeration	page 4
CME506 E Series Refrigeration	page 5
CME656 Refrigeration	page 6
CME806 Refrigeration	page 7
Receiver	page 8
Water System Components	page 9
Compressors and Electrical Components	page 10
HTB555 Ice Storage Bin	page 11
Remote Condenser	page 12
Wiring Diagrams	page 13

CME506R, CME656R & CME806R Service Parts

Cabinet

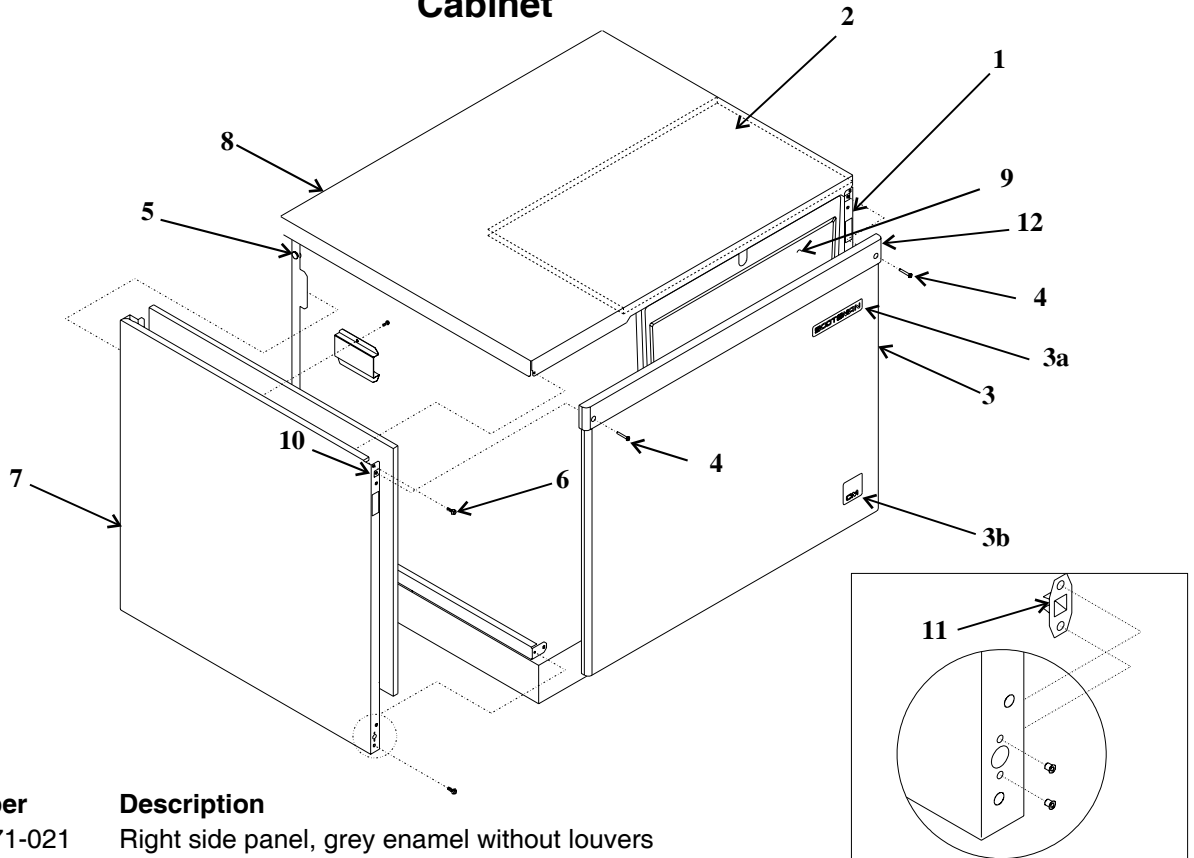

Item Number	Part Number	Description		
1	A37071-021	Right side panel, grey enamel without louvers		
	A37071-022	A - D series right side panel, stainless steel without louvers		
	A38126-021	E Series right side panel		
2	02-3659-01	Top insulation		
3	02-3797-21	C series Front panel kit, gray plastic , includes trim strip & emblems		
	03-1733-01	Strike (for C model panel, SS and plastic)		
	A37167-001	Front panel kit, gray plastic, includes item 10a (for A series)		
	A37488-021	C or higher series Front panel kit, stainless steel , includes trim strip & emblems		
	A35964-002	Front panel kit, stainless steel (for A models)		
3a	15-0808-01	Emblem for ss panel (Scotsman); 03-0271-00 is the speed nut for emblem		
3b	15-0792-02	Emblem for C to E series front panel, (CM ³)		
4	03-1735-01	Screw for trim strip (for C or D or E series)		
	03-1404-12	Sheet metal screw for plastic front panel (for A series)		
	03-1419-22	Sheet metal screw for ss front panel		
5	02-1875-03	Panel bumper/hole plug		
6	03-1531-01	Sheet metal screw for A - C series		
	03-1403-19	Machine screw for D series		
7	A37070-021	Left side panel, grey enamel without louvers A - D series only		
	A37070-022	Left side panel, stainless steel without louvers A - D series only		
	A38127-021	E Series Left side panel		
8	A35965-001	Top panel, grey enamel, order item 2 also		
	A35965-002	Top panel, stainless steel, order item 2 also		
	02-3822-21	Top panel, plastic, original with D series, fits all and includes item 2		
9a	02-3663-01	Evaporator cover, use began Feb. 1997. For A and B series		
	02-3796-01	Evap cover insulation for above cover		
	02-3663-20	Evaporator cover w/ins for C - higher series		
10	03-1423-06	Speed nut for panel screws		
11	03-1733-02	Catch		
		12	02-3794-31	Trim strip.
			03-1731-02	Push nut for trim strip

CME506R, CME656R & CME806R Service Parts

Interior Structure & Controls

Note: Item 25 mounts to Item 1.
Item 1 must have rectangular tabs. All units after 9/96 were mfg. with rectangular tabs.

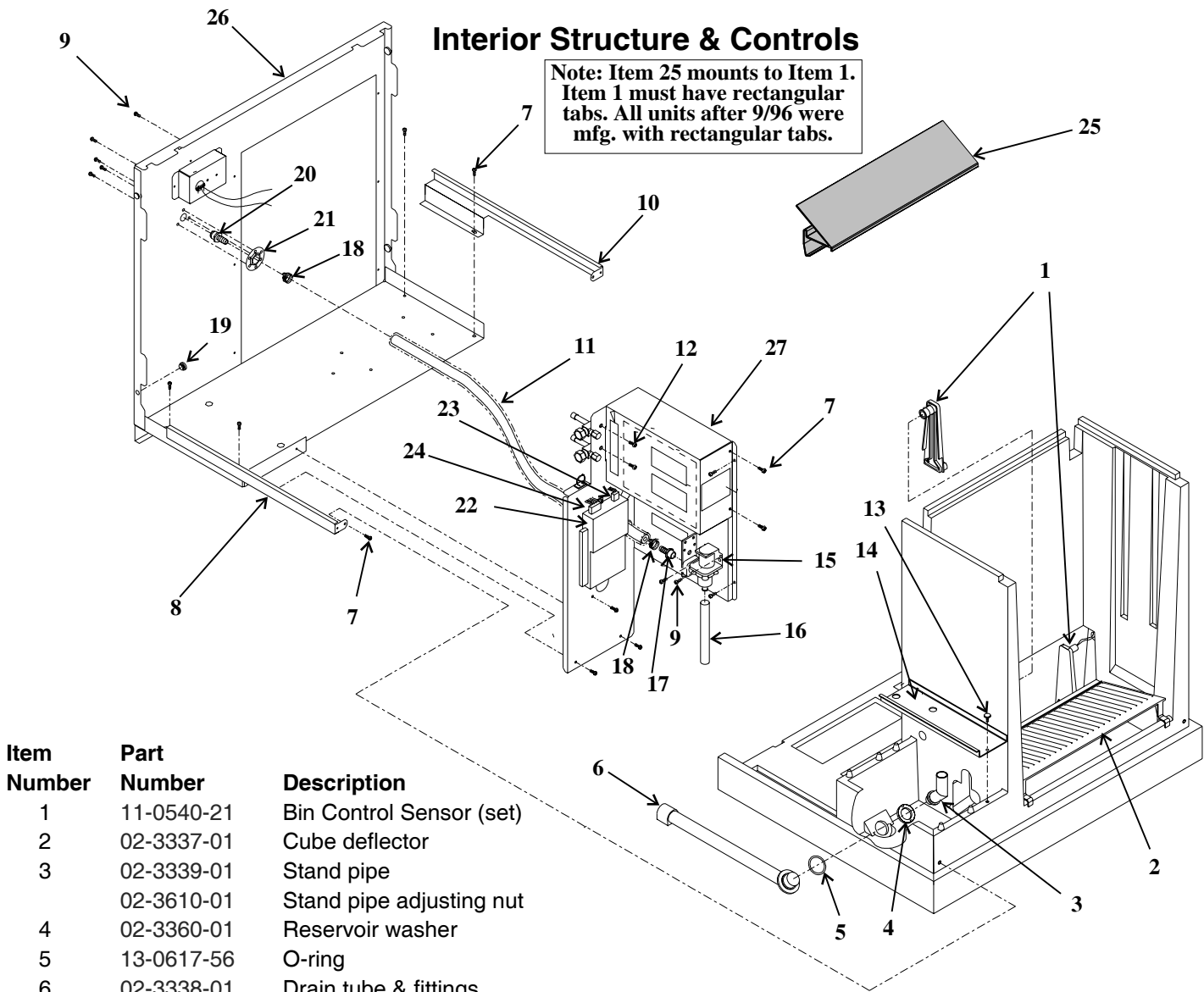

Item Number	Part Number	Description
1	11-0540-21	Bin Control Sensor (set)
2	02-3337-01	Cube deflector
3	02-3339-01	Stand pipe
	02-3610-01	Stand pipe adjusting nut
4	02-3360-01	Reservoir washer
5	13-0617-56	O-ring
6	02-3338-01	Drain tube & fittings
7	03-1404-18	Screw
8	A36298-001	Left side channel
9	03-1404-07	Screw
10	A36297-001	Right side channel
11	13-0906-01	Plastic Inlet water tube, 21"
		not used after Sept. 1996
12	03-1645-01	Screw
13	03-1691-01	Nylon screw
14	02-3340-01	Reservoir cover
15	12-2548-01	Inlet water valve
16	13-0674-02	Tubing, 9" req., order 1 unit
17	obsolete	Water inlet fitting for hose
	16-1020-01	Water fitting for copper
18	obsolete	Clamp for hose
19	13-0903-01	Bumper for side panels
20	16-0997-01	Inlet water fitting for hose
	16-1019-01	Inlet water fitting for copper

Item Number	Part Number	Description
21	16-0701-07	Mounting flange
22	12-2838-23	System controller, fits all
23	12-2541-21	Hi Voltage harness A - C
	12-2785-01	Hi voltage harness - D series
24	12-2644-02	Lo voltage harness A - C
	12-2782-02	Lo voltage harness, D + series
25	02-3657-01	Cascading shield, use began 2/97.
26	A36460-001	Back panel assy
27	A35959-001	Hi voltage box cover

CME506R A - D Series Refrigeration System

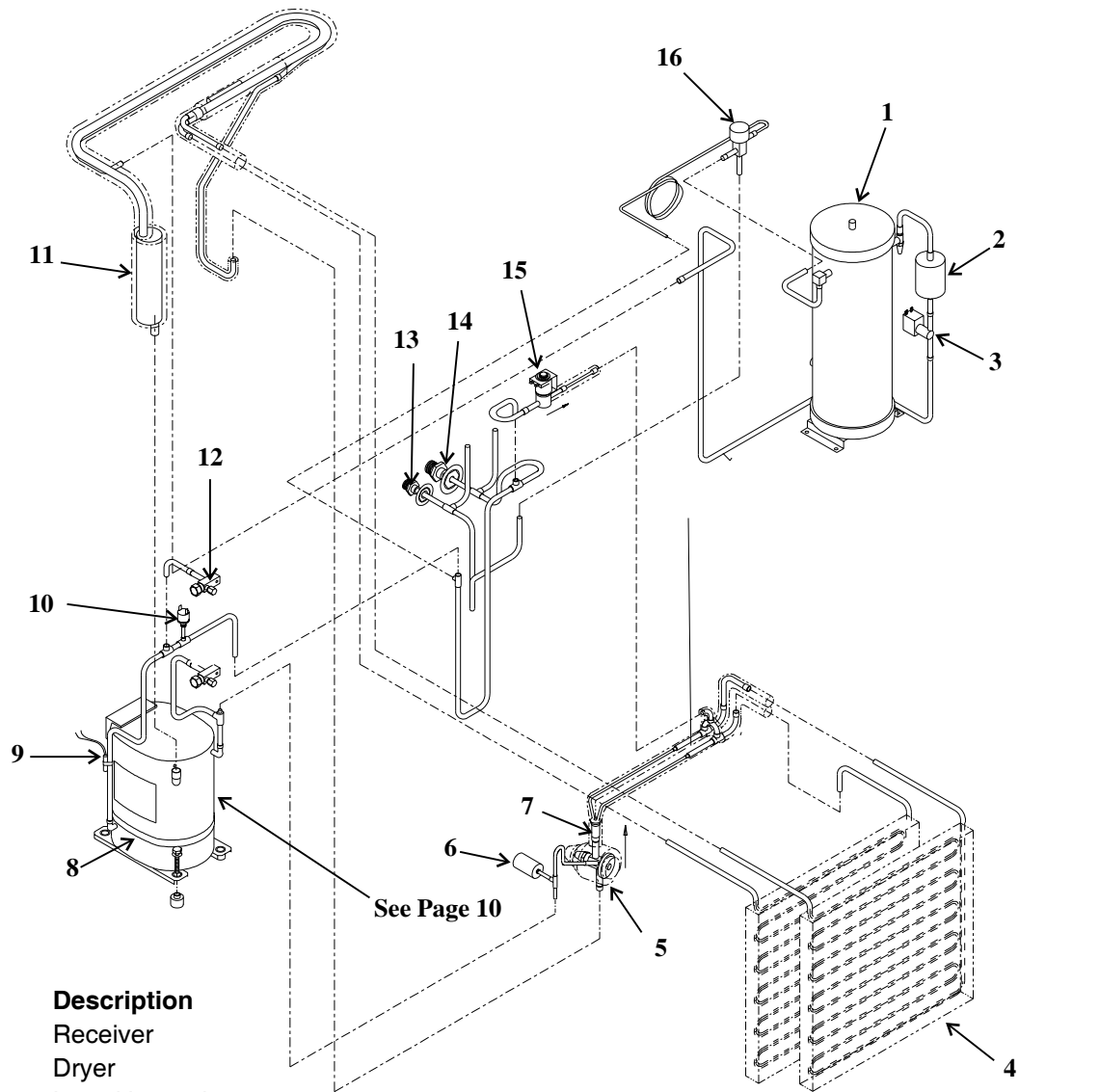

Item Number	Part Number	Description	
1	16-0761-01	Receiver	
2	02-3319-02	Dryer	
3	12-2471-23	Liquid line valve	
4	A36734-020	Evaporator	
5	16-1017-21	TXV	
	02-2920-01	Insulation for TXV	
6	11-0502-21	Pump down pressure switch	
7	16-0843-03	Distributor and tubes	
8	12-1868-01	Crankcase heater	
9	02-3410-21	Discharge line temperature sensor, includes water temp sensor & clip	
	03-1711-01	Sensor clip	
10	11-0501-22	Hi pressure cut out switch	
11	16-0778-21	Accumulator	
12	16-0832-20	Access valve	
	16-0832-03	Port cap	
	16-0832-02	Stem cap	
13	16-0850-03	Liquid line fitting	
14	16-0850-01	Discharge line fitting	
15	12-2471-22	Hot gas valve complete	
	12-2719-23	Hot gas valve coil	
	16	11-0422-24	Discharge pressure control valve
	17	16-1063-01	Hot gas valve strainer, not shown

CME506R E & Higher Series Refrigeration System

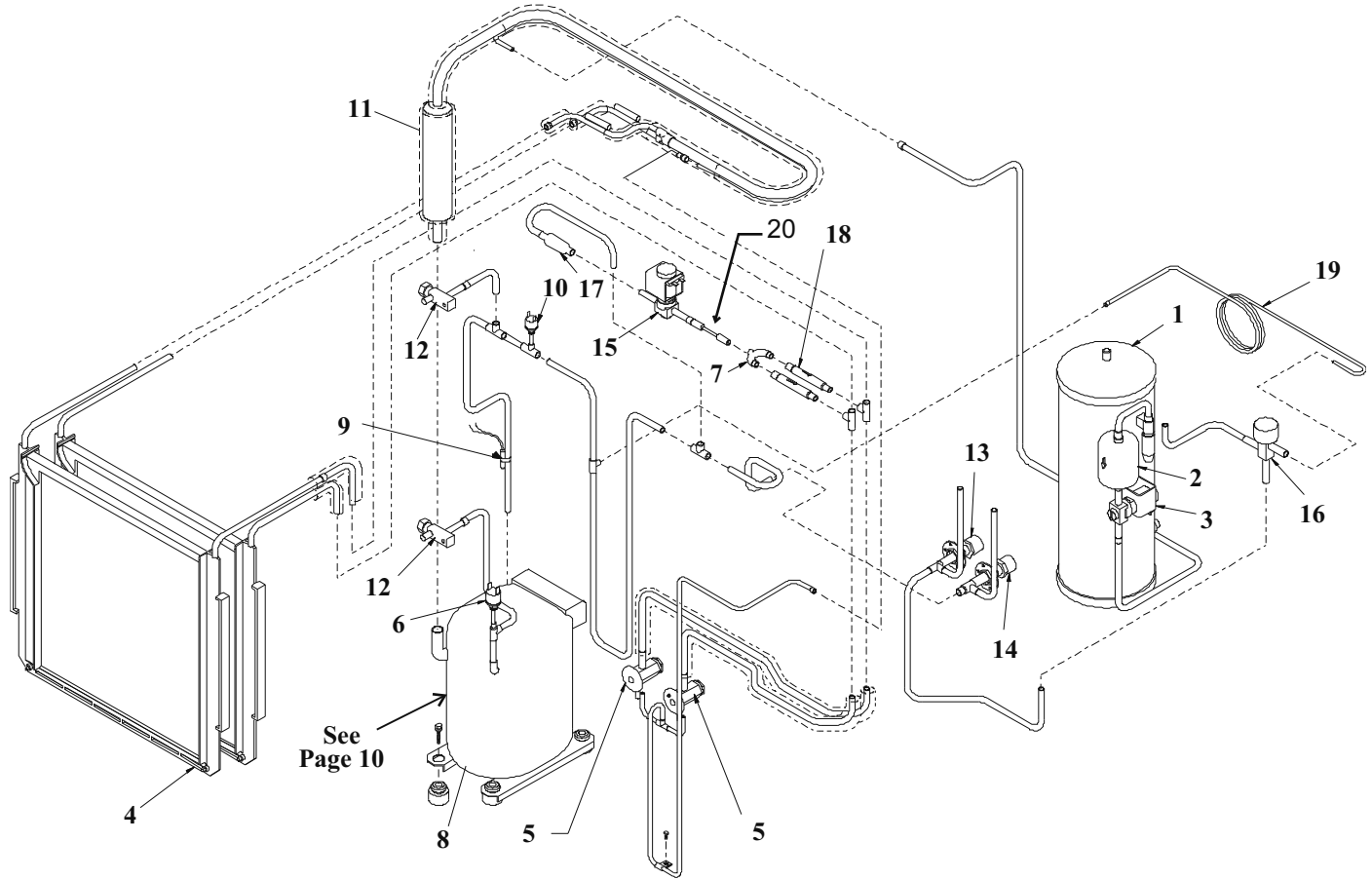

See Page 10

Item Number	Part Number	Description	Item Number	Part Number	Description
1	16-0761-01	Receiver	16	11-0422-24	Discharge pressure control valve
2	02-3319-02	Dryer	17	16-1063-01	Hot gas valve strainer
3	12-2471-23	Liquid line valve	18	16-1071-01	Check valve
4	A36734-020	Evaporator	19	A36427-001	By-pass tubing
5	16-1009-22	TXV - only for E series	20	16-1095-01	Restrictor
	02-3792-01	Insulation for TXV			
6	11-0502-21	Pump down pressure switch			
7	16-0776-01	Tee			
8	12-1868-01	Crankcase heater			
9	02-3410-21	Discharge line temperature sensor, includes water temp sensor & clip			
	03-1711-01	Sensor clip			
10	11-0501-22	Hi pressure cut out switch			
11	16-0778-21	Accumulator			
12	16-0832-20	Access valve			
	16-0832-03	Port cap			
	16-0832-02	Stem cap			
13	16-0850-03	Liquid line fitting			
14	16-0850-01	Discharge line fitting			
15	12-2471-22	Hot gas valve complete			
	12-2719-23	Hot gas valve coil			

CME656R Refrigeration System

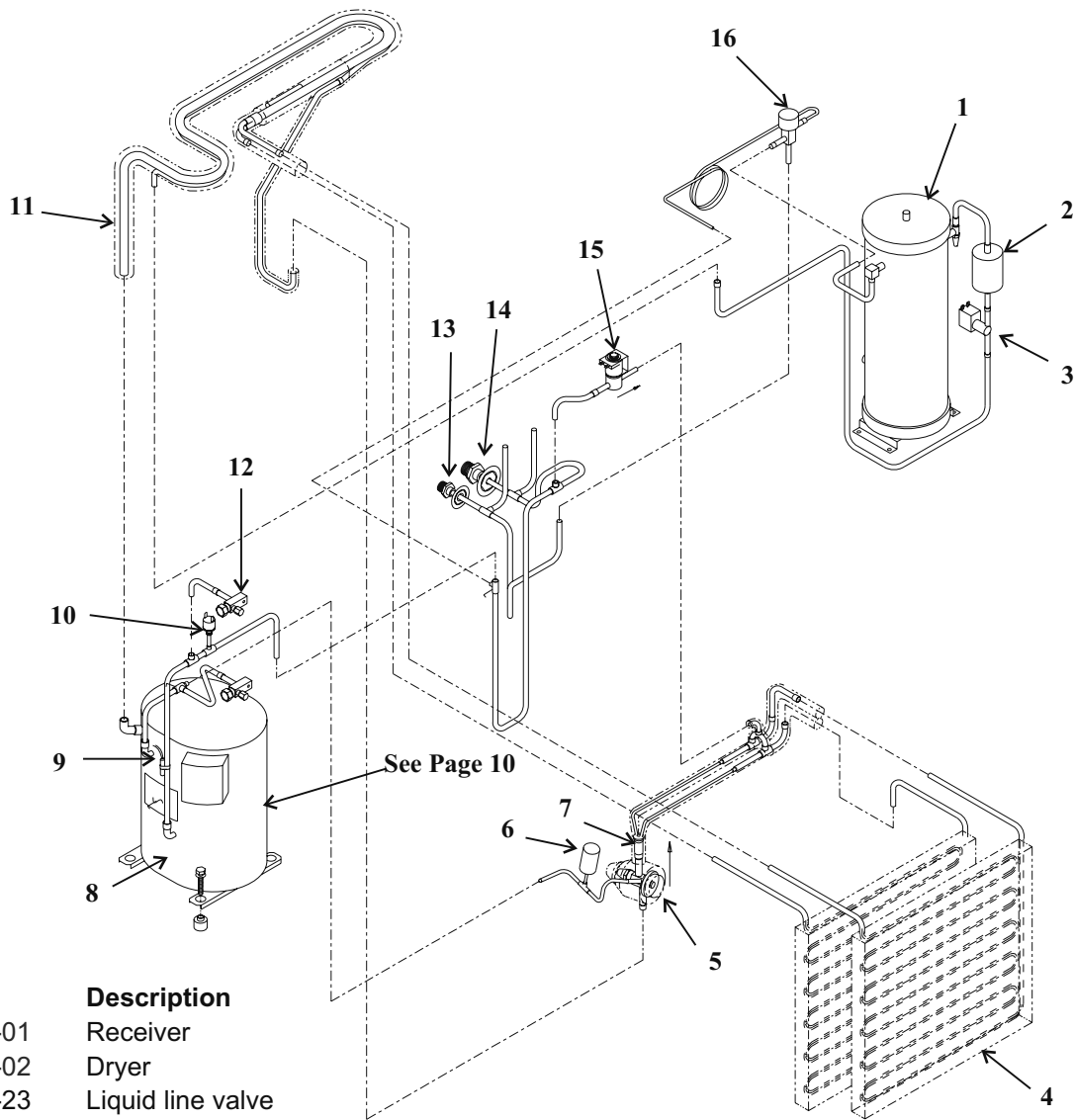

Item Number	Part Number	Description	
1	16-0761-01	Receiver	
2	02-3319-02	Dryer	
3	12-2471-23	Liquid line valve	
4	A36734-020	Evaporator	
5	16-1076-21	TXV (interchangeable with all prior valves)	
	02-2920-01	Insulation for TXV	
6	11-0502-21	Pump down pressure switch	
7	16-0843-02	Distributor and tubes	
8	12-2308-01	Crankcase heater	
9	02-3410-21	Discharge line temperature sensor, includes water temp sensor & clip	
	03-1711-01	Sensor clip	
10	11-0501-22	Hi pressure cut out switch	
11	no number	Suction line	
12	16-0832-20	Access valve	
	16-0832-03	Port cap	
	16-0832-02	Stem cap	
13	16-0850-03	Liquid line fitting	
14	16-0850-01	Discharge line fitting	
15	12-2471-22	Hot gas valve complete	
	12-2719-23	Hot gas valve coil	
	16	11-0422-24	Discharge pressure control valve
	17	16-1063-01	Hot gas valve strainer, not shown

CME806R Refrigeration System

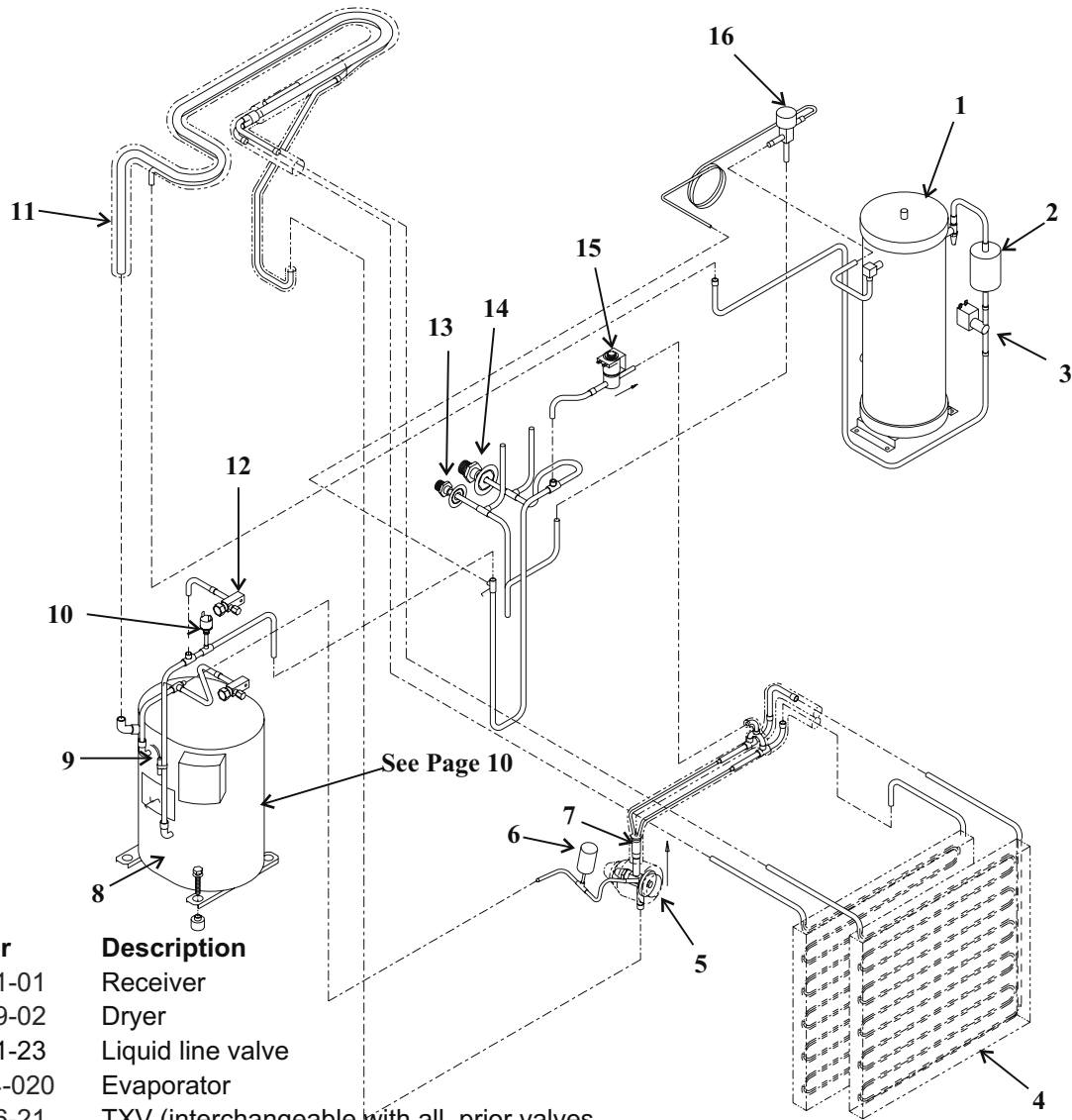

Item Number	Part Number	Description
1	16-0761-01	Receiver
2	02-3319-02	Dryer
3	12-2471-23	Liquid line valve
4	A36734-020	Evaporator
5	16-1076-21	TXV (interchangeable with all prior valves)
	02-3396-01	Insulation for TXV
6	11-0502-21	Pump down pressure switch
7	16-0843-02	Distributor and tubes
8	12-2308-01	Crankcase heater
9	02-3410-21	Discharge line temperature sensor, includes water temp sensor & clip
	03-1711-01	Sensor clip
10	11-0501-22	Hi pressure cut out switch
11	no number	Suction line
12	16-0832-20	Access valve
	16-0832-03	Port cap
	16-0832-02	Stem cap
13	16-0850-03	Liquid line fitting
14	16-0850-01	Discharge line fitting
15	12-2471-24	Hot gas valve complete
	12-2719-23	Hot gas valve coil
16	11-0422-23	Discharge pressure control valve

CME506R, CME656R & CME806R Service Parts

Receiver

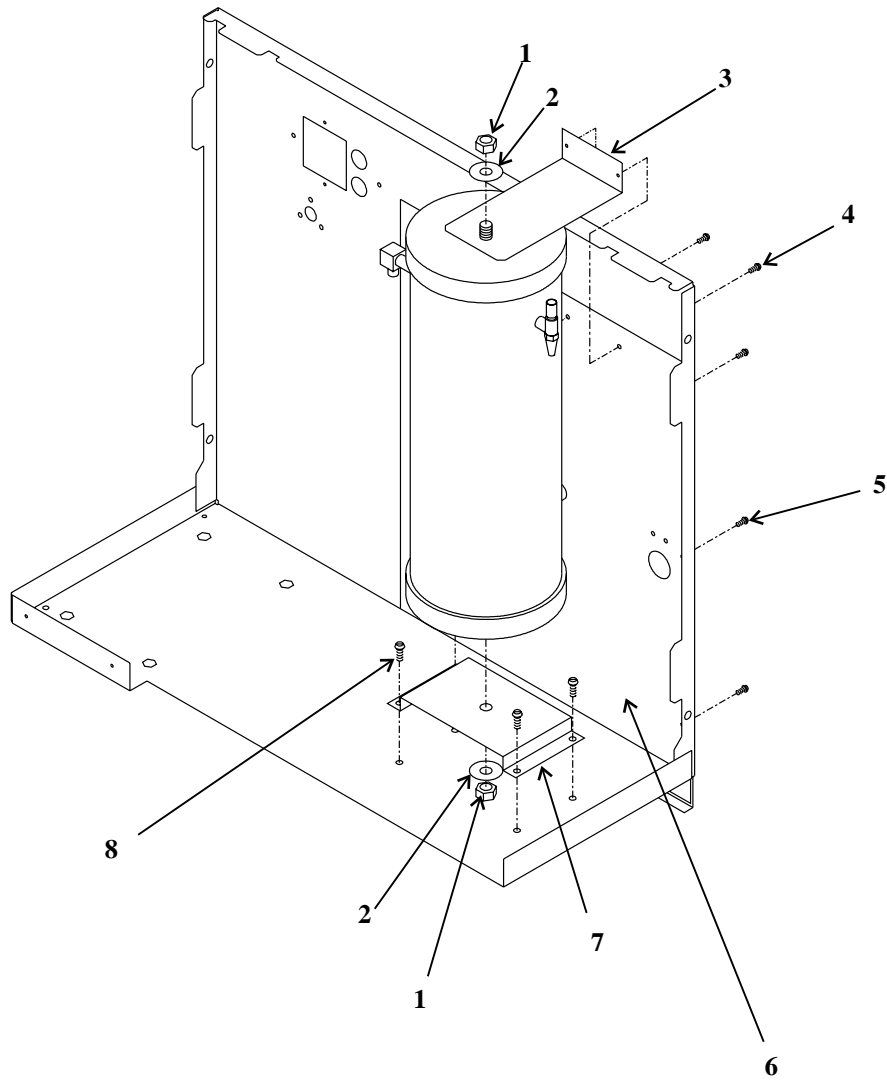

Item Number	Part Number	Description
1	03-1406-13	Nut
2	03-1410-06	Washer
3	A36454-001	Bracket
4	03-1638-03	Screw
5	03-1531-01	Screw
6	A36440-001	Back cover
7	A36021-001	Bracket
8	03-1645-01	Screw

CME506R, CME656R & CME806R Service Parts

Water System Components

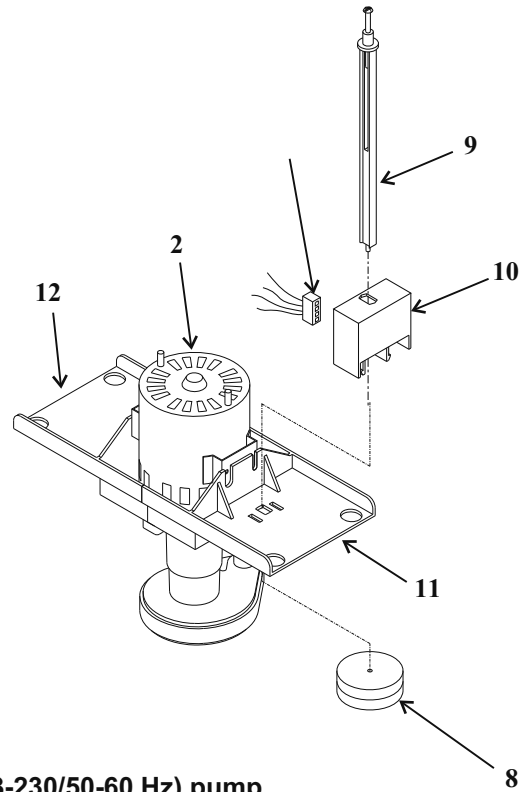
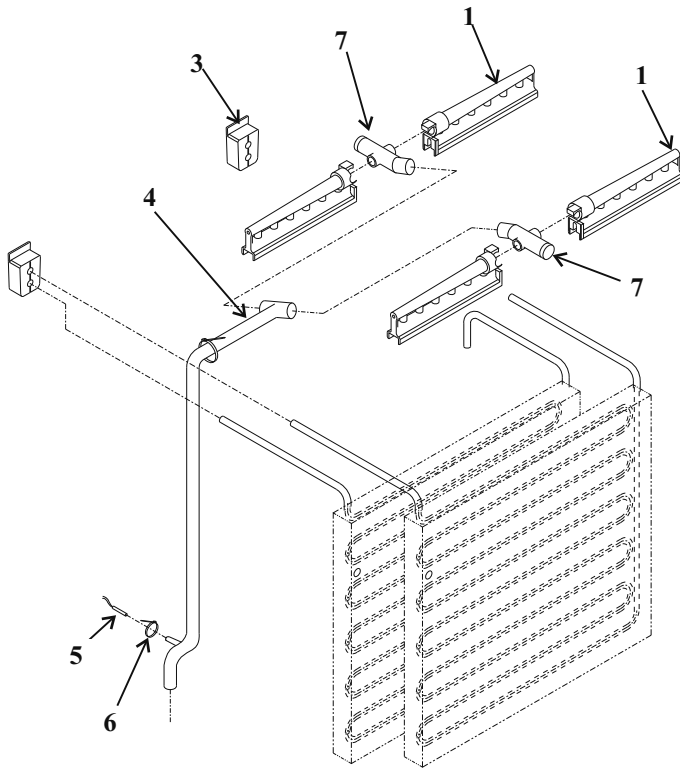

Item Number	Part Number	Description
1	02-2527-01	Water distributor
2	12-2586-27	CME506-1 pump (115/60 Hz)
	12-2586-23	CME656 or CME506-6 or CME806 (203-230/50-60 Hz) pump
3	13-0898-01	Tubing grommet
4	02-3336-01	Water distributor tube
5	02-3410-21	Water temperature sensor includes disch. temp. sensor
6	no number	Cable tie
7	02-3405-01	Inlet Tee
	13-0840-01	Rubber plug
8	02-3341-01	Float
9	02-3383-02	Float stem grey, non adjustable after 2/97
10	11-0539-51	Float sensor
11	02-3388-04	Front pump bracket for 12-2586 type pump
12	02-3388-05	Rear pump bracket for 12-2586 type pump
13	12-2506-01	Harness

CME506R, CME656R & CME806R Service Parts

Compressors and Electrical Components

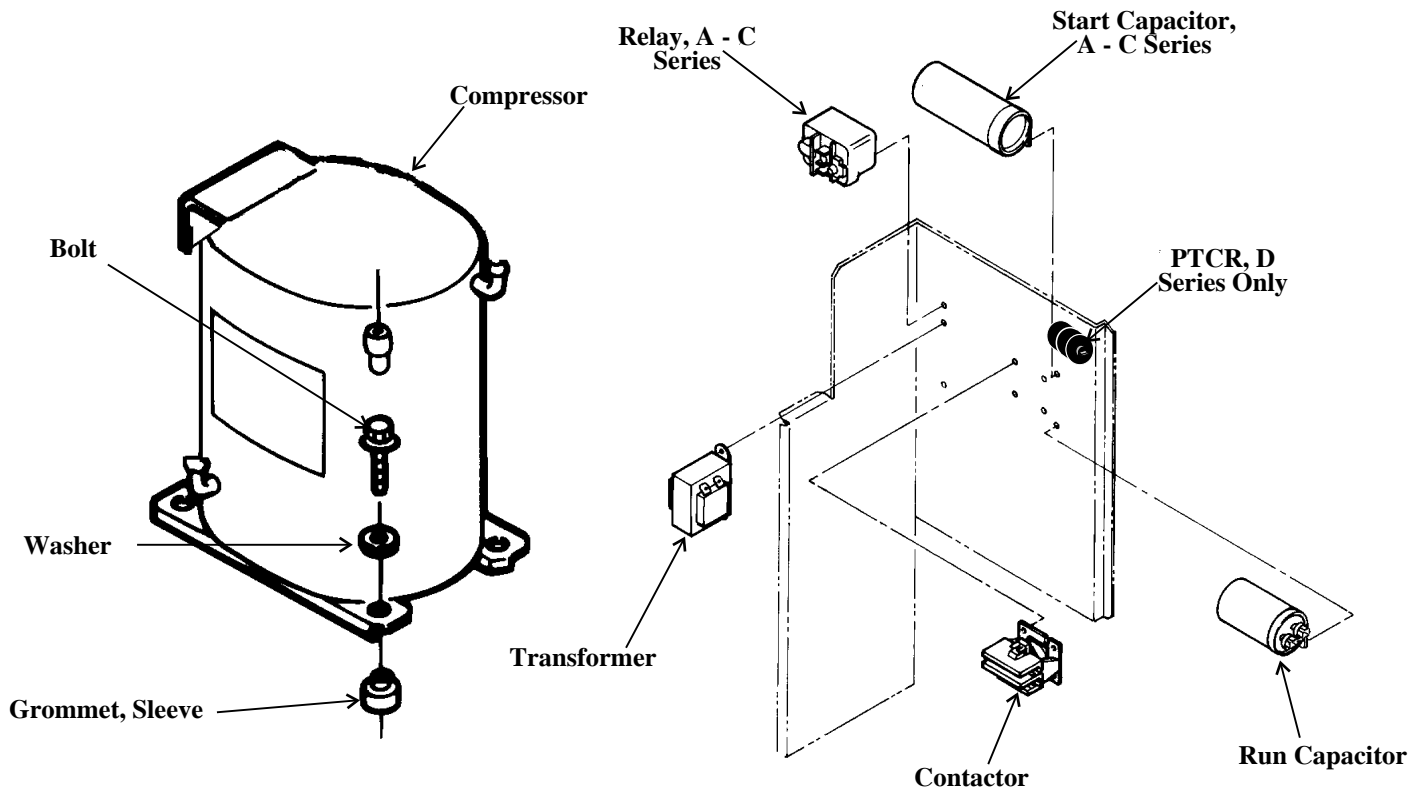

Model	CME506		CME656			CME806	
Voltage/Hz	115/60	250/50	208-230/60	208-230/60	250/50	208-230/60	230/50
Phase	Single	Single	Single	Three	Single	Single	Single
Compressor*	18-8721-21*	18-8721-22	18-8813-23*	18-8813-25	18-8813-27	18-8749-22*	18-8749-27
PTCR** D series	18-8835-01	18-8835-01	18-8835-01	18-8835-01	18-8835-01	18-8835-01	18-8835-01
Start Relay**	18-1903-50	18-1903-29	18-1903-33	not used	18-1903-29	18-1903-46	18-1903-33
Start Capacitor**	18-1901-03	18-1901-43	18-1901-15	not used	18-1901-52	18-1901-48	18-1901-48
Run Capacitor	18-1902-45	18-1902-30	18-1902-53	not used	18-1902-53	18-1902-55	18-1902-55
Overload	18-8711-50	18-8721-50	internal	internal	internal	internal	internal
Mounting Bolt	03-1405-20	03-1405-20	03-1405-20	03-1405-20	03-1405-20	03-1405-20	03-1405-20
Sleeve	18-2200-27	18-2200-27	18-2200-27	18-2200-27	18-2200-27	18-2200-27	18-2200-27
Washer	03-1407-07	03-1407-07	03-1407-07	03-1407-07	03-1407-07	03-1407-07	03-1407-07
Grommet	18-2200-28	18-2200-28	18-2200-28	18-2200-28	18-2200-28	18-2200-28	18-2200-28
Contactor	12-2469-01	12-2469-01	12-2469-01	12-2533-01	12-2469-01	12-2469-01	12-2469-01
Transformer	A37231-001	A37217-001	A37217-001	A37217-001	A37217-001	A37217-001	A37217-001

CME506R, CME656R & CME806R Service Parts

HTB555 Ice Storage Bin

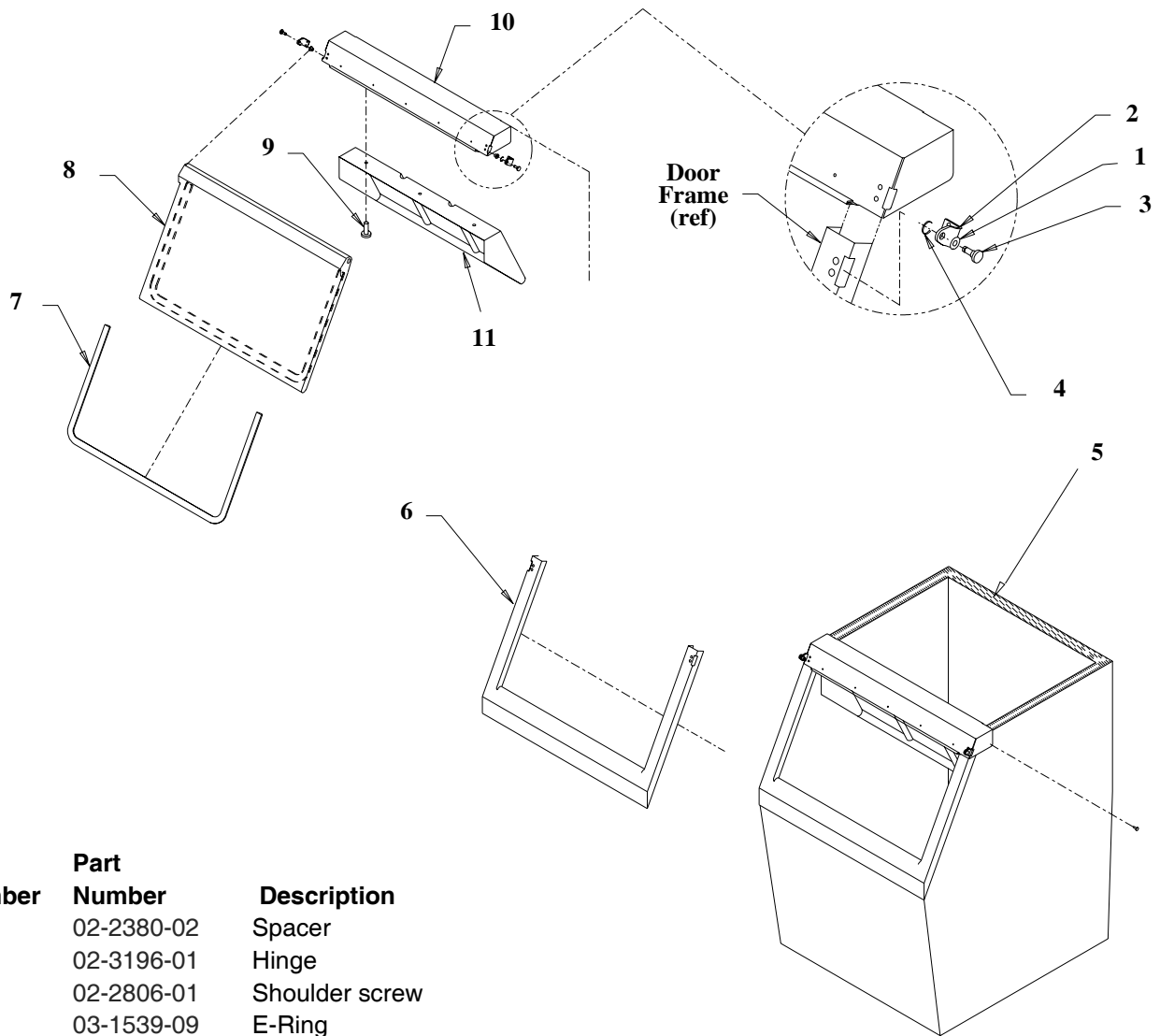

Item Number	Part Number	Description
1	02-2380-02	Spacer
2	02-3196-01	Hinge
3	02-2806-01	Shoulder screw
4	03-1539-09	E-Ring
5	19-0503-04	Gasket, order 9 units
6	02-3274-02	Door frame - Grey
7	13-0909-01	Door gasket, order 5 units
8	A36481-022	Door - Grey
9	03-0727-11	Thumb screw
10	A35637-001	Canopy
11	A37310001	Baffle
12	02-2809-02	Drain top
13	13-0617-09	O-Ring
14	02-3108-01	Drain bottom
Not shown	05-0586-01	Drain elbow
	02-0540-00	Scoop

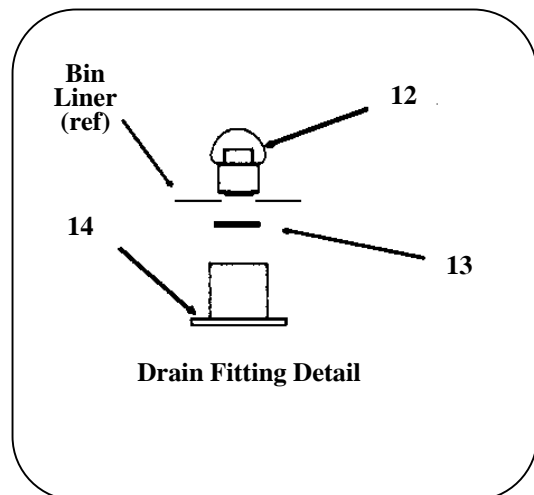

CME506R, CME656R & CME806R Service Parts

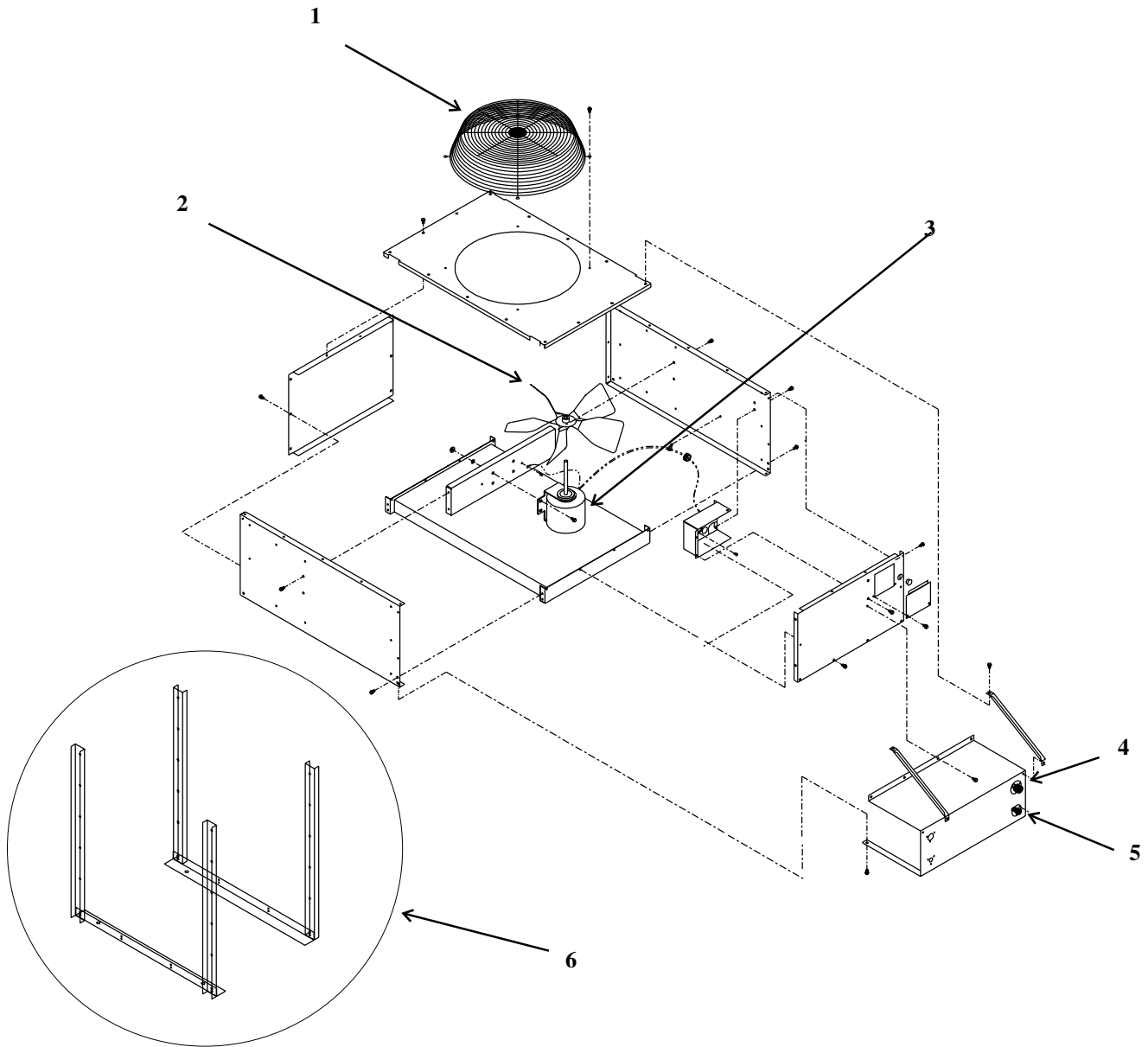

ITEM NUMBER	NUMBER	PART DESCRIPTION
1	02-3575-01	Fan guard
2	18-8800-01	Fan blade
3	18-8796-01	Fan motor ERC101
	18-8796-32	Fan motor ERC201, ERC402
4	16-0850-01	Quick connect, discharge
5	16-0850-03	Quick connect, liquid
6	A36990-001	Leg kit for ERC101, 201
	A36990-002	Leg kit for ERC402
Filters:		
	02-3231-03	Discharge line
	02-3231-02	Liquid line

CME506R, CME656R & CME806R Service Parts

D Series, Single Phase Schematic Diagram

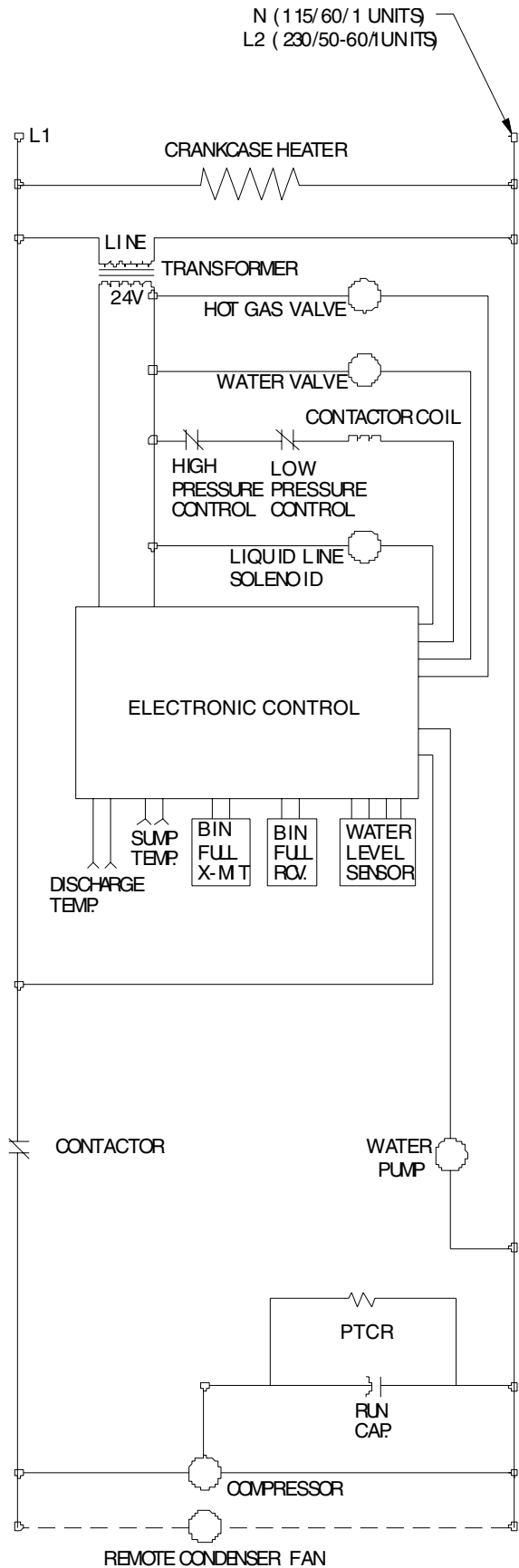

CME506R, CME656R & CME806R Service Parts

D Series, CME506R Wiring Diagram

17-2748-01

USE COPPER CONDUCTORS ONLY

- 1 DASHED LINES INDICATE FIELD WIRING WHICH MUST BE INSTALLED IN ACCORDANCE WITH THE NATIONAL ELECTRICAL CODE AND ALL STATE AND LOCAL CODES.
- 2 WIRE COLOR FOR 115/60/1 UNITS: BLACK
WIRE COLOR FOR 230/50/1 UNITS: BLUE
- 3 WIRE COLOR FOR 115/60/1 UNITS: WHITE
WIRE COLOR FOR 230/50/1 UNITS: BROWN

CAUTION: PTCR WILL BE HOT.
COMPRESSOR MAY NOT START IF
PTCR IS NOT ALLOWED TO COOL.

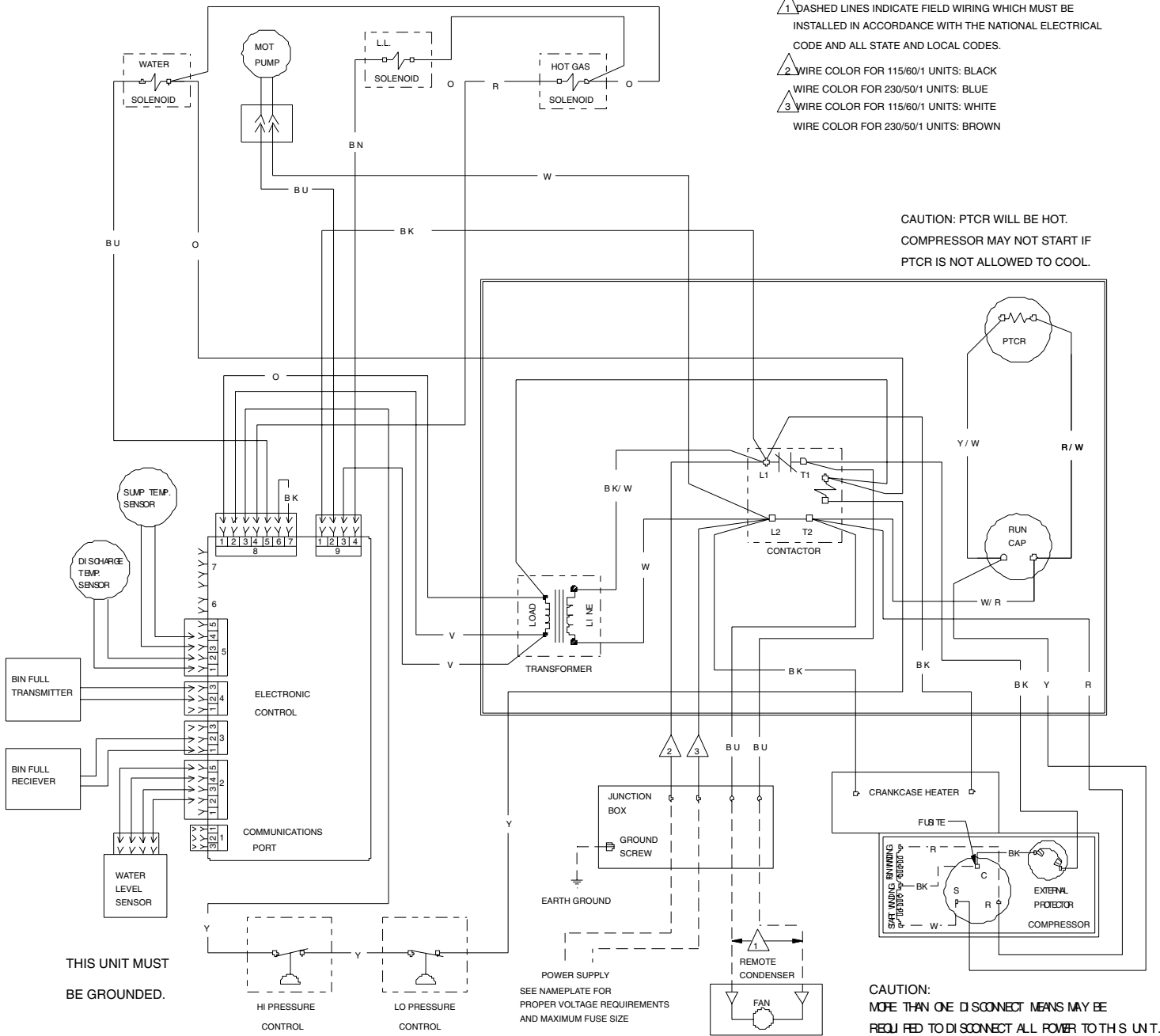

THIS UNIT MUST
BE GROUNDED.

POWER SUPPLY
SEE NAMEPLATE FOR
PROPER VOLTAGE REQUIREMENTS
AND MAXIMUM FUSE SIZE

CAUTION:
MORE THAN ONE DISCONNECT MEANS MAY BE
REQUIRED TO DISCONNECT ALL POWER TO THIS UNIT.

CME506R, CME656R & CME806R Service Parts

D Series, CME656R and CME806R Single Phase Wiring Diagram

17-2751-01

USE COPPER CONDUCTORS ONLY

△ DASHED LINES INDICATE FIELD WIRING WHICH MUST BE INSTALLED IN ACCORDANCE WITH THE NATIONAL ELECTRICAL CODE AND ALL STATE AND LOCAL CODES.

CAUTION: PTCR WILL BE HOT. COMPRESSOR MAY NOT START IF PTCR IS NOT ALLOWED TO COOL.

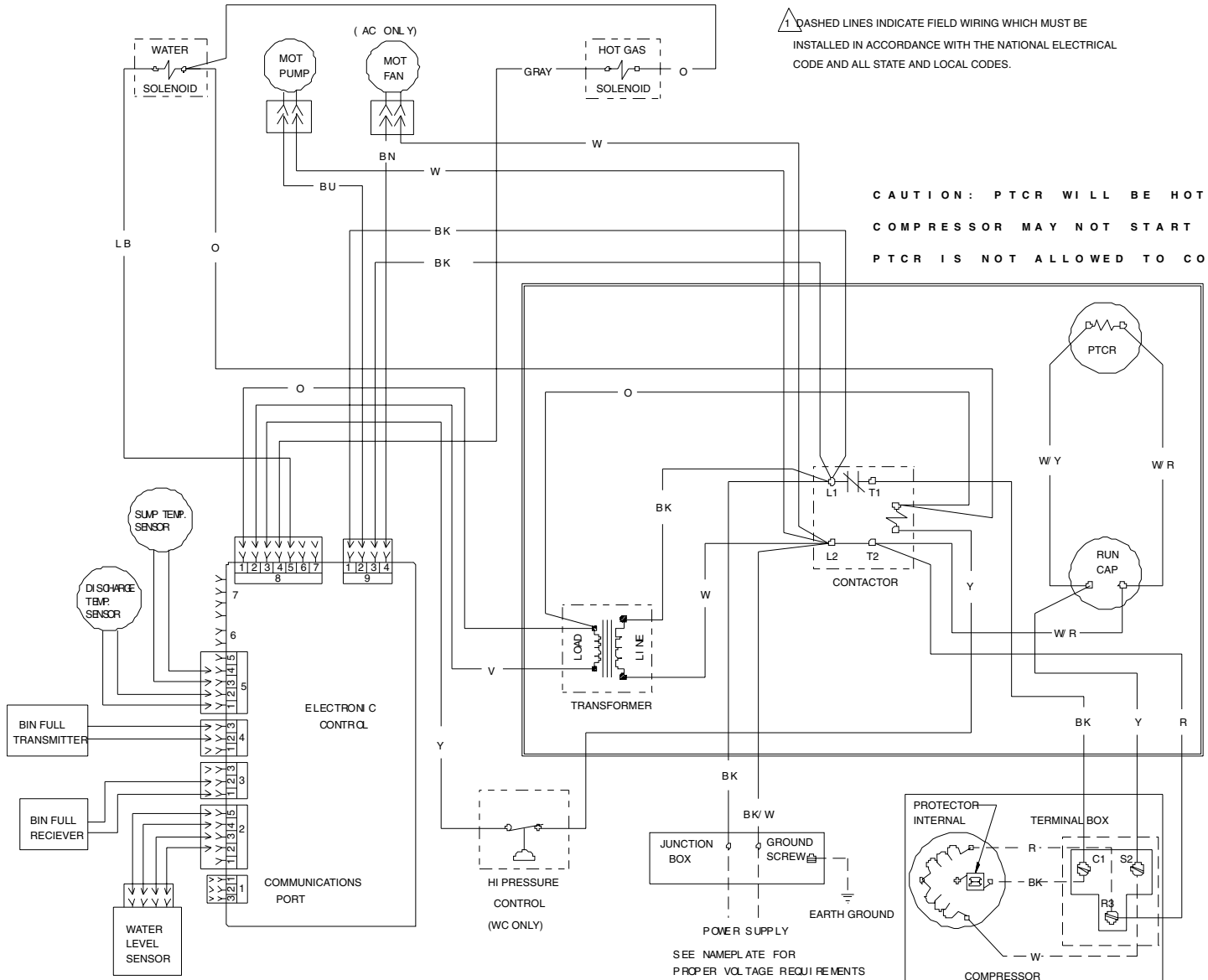

THIS UNIT MUST BE GROUNDED.

CAUTION:
MORE THAN ONE DISCONNECT MEANS MAY BE REQUIRED TO DISCONNECT ALL POWER TO THIS UNIT.

SEE NAMEPLATE FOR PROPER VOLTAGE REQUIREMENTS AND MAXIMUM FUSE SIZE

CME506R, CME656R & CME806R Service Parts

D Series, Three Phase Schematic Diagram

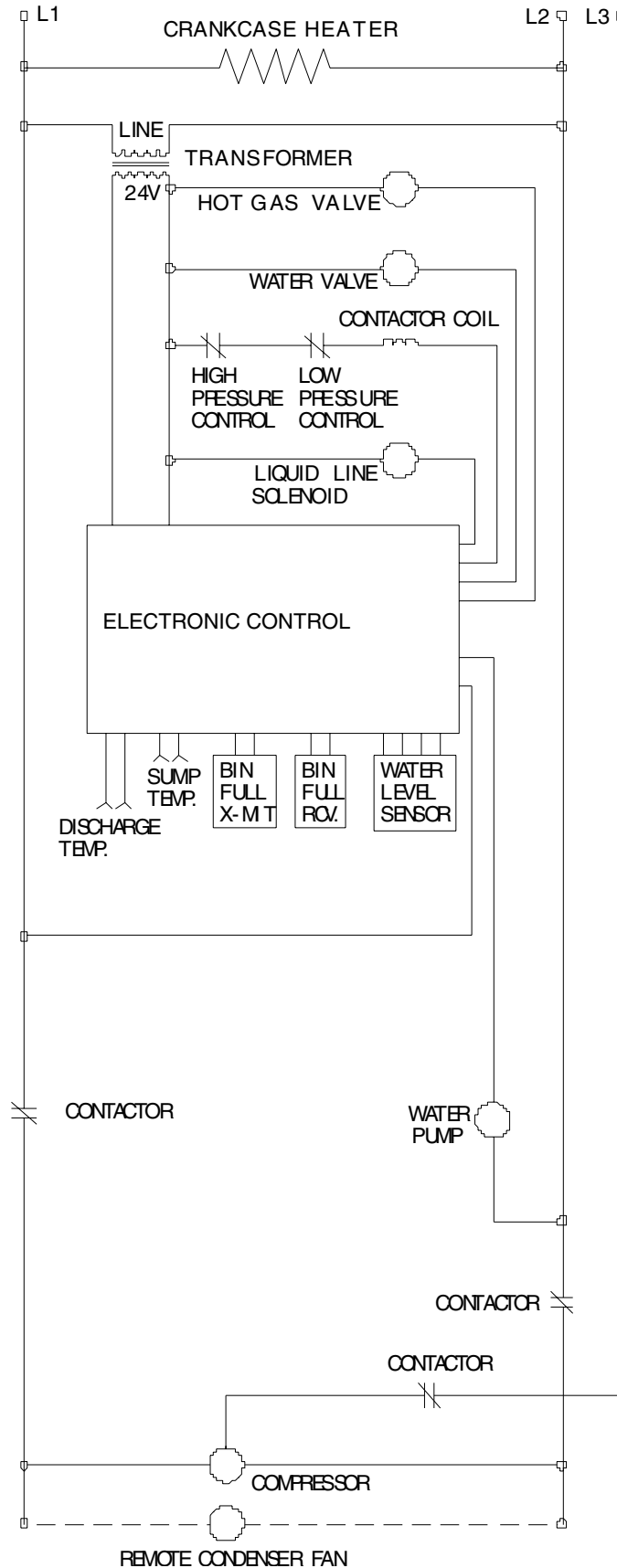

CME506R, CME656R & CME806R Service Parts

D Series, Three Phase Wiring Diagram

17-2758-01

USE COPPER CONDUCTORS ONLY

1 DASHED LINES INDICATE FIELD WIRING WHICH MUST BE INSTALLED IN ACCORDANCE WITH THE NATIONAL ELECTRICAL CODE AND ALL STATE AND LOCAL CODES.

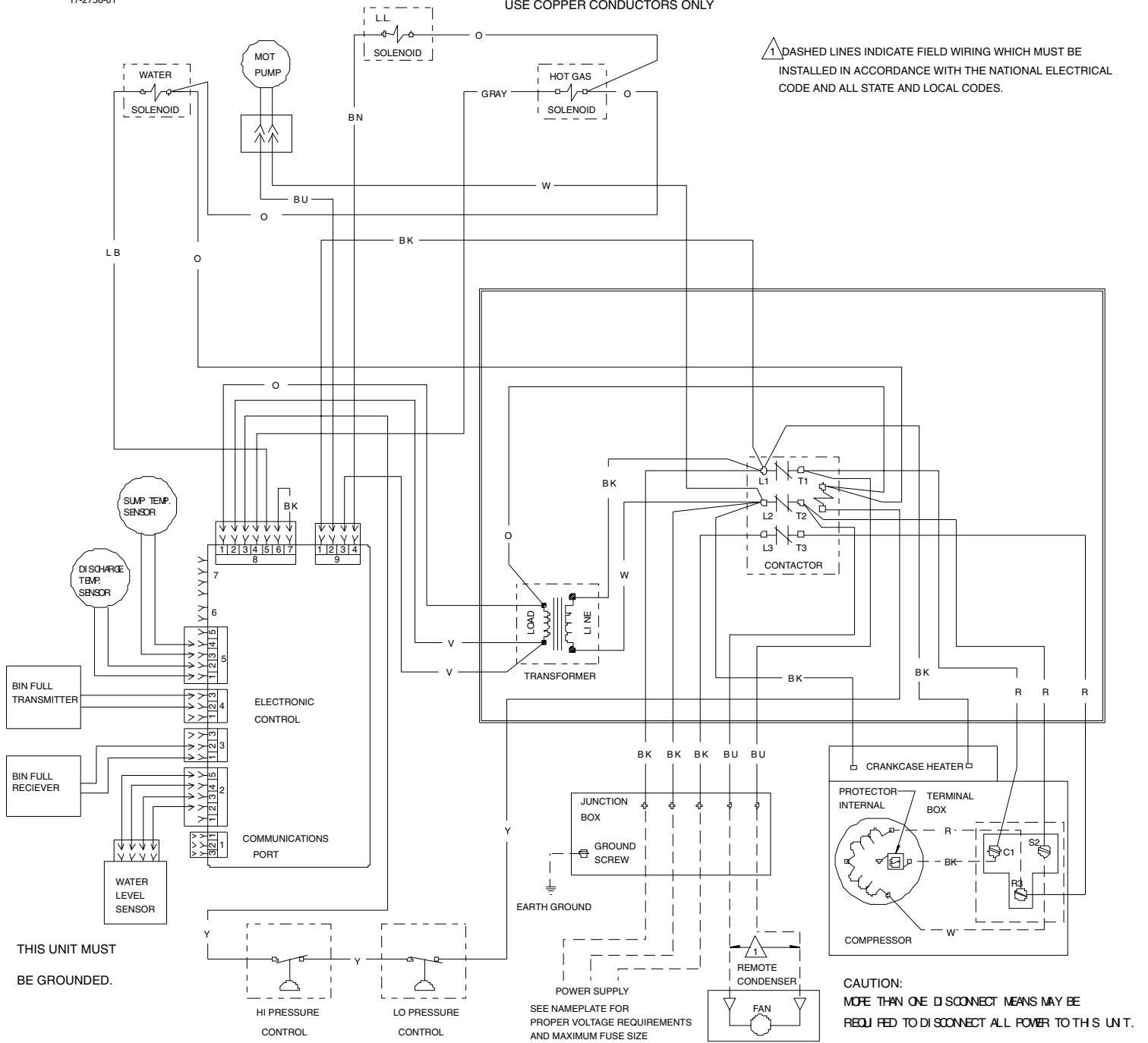

CME506R, CME656R & CME806R Service Parts

Single Phase Schematic Diagram, A - C Series

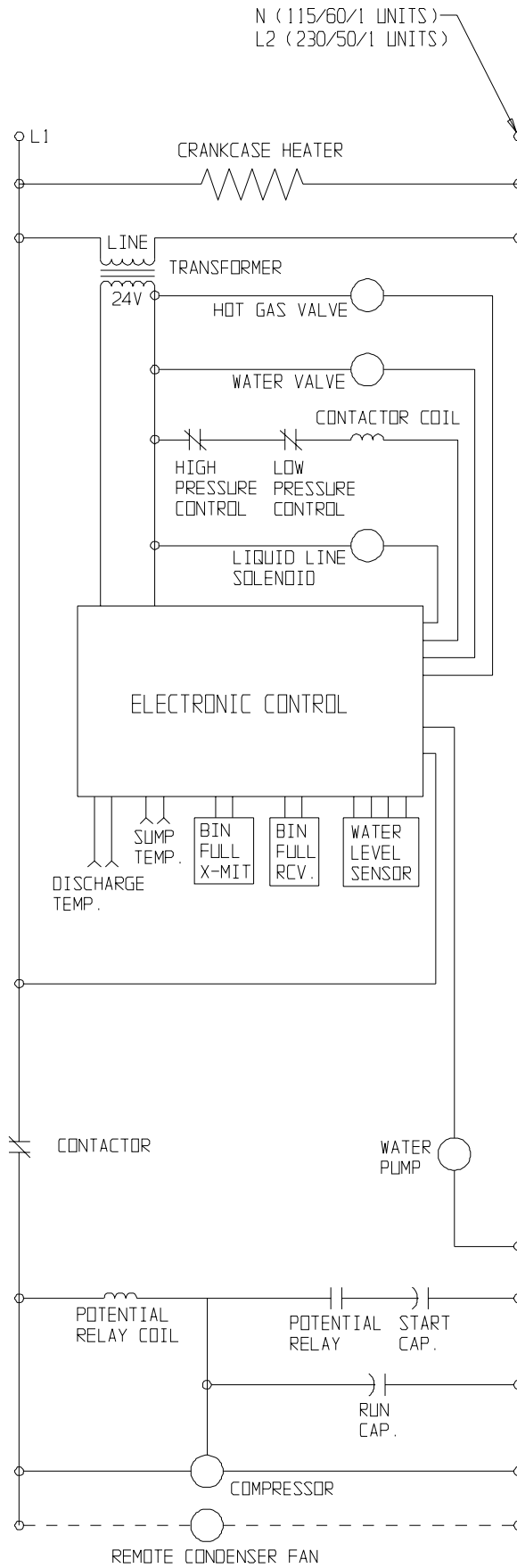

CME506R, CME656R & CME806R Service Parts

A-C Series Single Phase Wiring Diagram

A36671-001

USE COPPER
CONDUCTORS ONLY

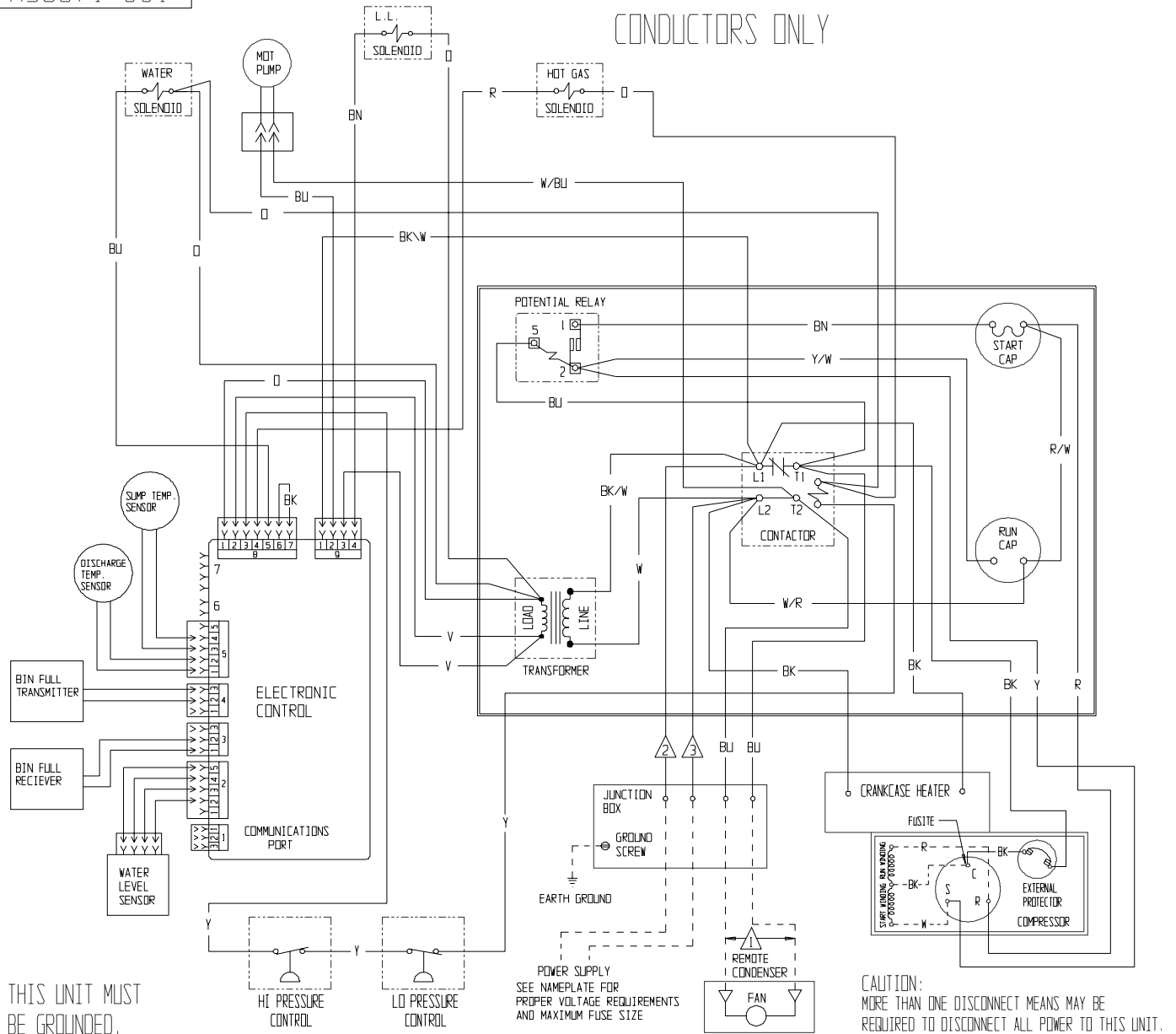

THIS UNIT MUST
BE GROUNDED.

CAUTION:
MORE THAN ONE DISCONNECT MEANS MAY BE
REQUIRED TO DISCONNECT ALL POWER TO THIS UNIT.

A -C Series Three Phase Schematic Diagram

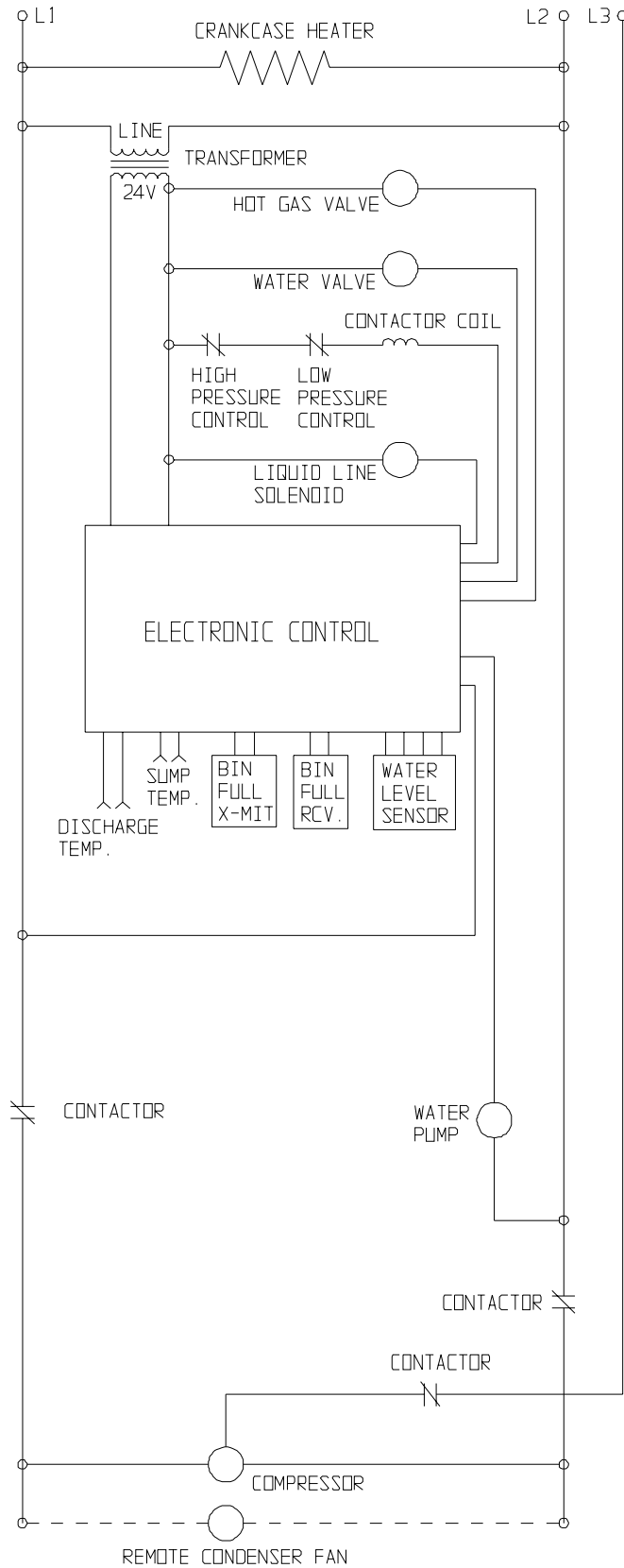

CME506R, CME656R & CME806R Service Parts

A - C Series Three Phase Wiring Diagram

A36660-003

USE COPPER CONDUCTORS ONLY

