

# CME855A & CME1000A SERVICE PARTS

This parts list contains the parts for both the CME855 and CME1000 air cooled. Some models have been manufactured in single and three phase.

In addition, the some have been manufactured in 50 cycle (Hz).

- 60 Hz model numbers end in -32 or -3
- 50 Hz model numbers end in -6.

Check the model number and voltage to be certain of obtaining the correct parts.

## TABLE OF CONTENTS

Cabinet.....	Page 2
Refrigeration.....	Page 3
Fan motor .....	Page 4
Water System .....	Page 5
Control Box .....	Page 6
Ice storage bin .....	Page 7
Wiring Diagrams .....	Page 8

# CME855A & CME1000A SERVICE PARTS

## Cabinet

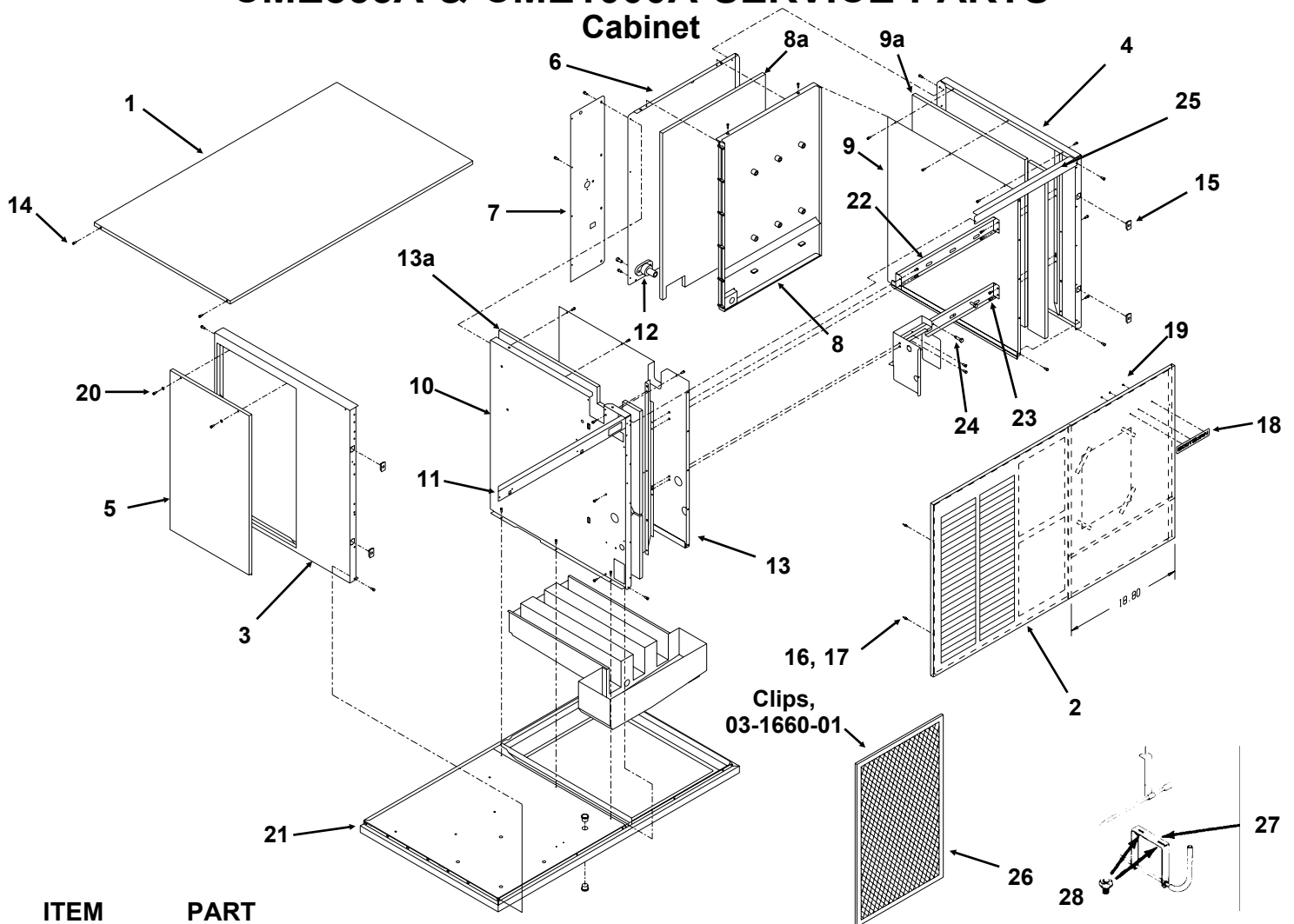

ITEM NUMBER	PART NUMBER	DESCRIPTION	ITEM NUMBER	PART NUMBER	DESCRIPTION
1	A32461-001	Top panel, sandalwood	10	A36406-015	Retainer
	A32461-015	Top panel, gray	11	A32468-001	Brace, upper left
	A32461-002	Top panel, S.S.	12	A31757-002	Drain fitting
2.	A32457-001	Front panel, sandalwood	13	02-2885-01	Left liner
	A32457-015	Front panel, gray	13a	A32458-003	Left insulation
	A32457-002	Front panel, S.S.	14	03-1531-01	Screw, top panel
3	A32435-001	End panel left. sandalwood	15	02-0836-00	Cabinet catch
	A32435-015	End panel left, gray	16	15-0411-00	Strike
	A32435-002	End panel left, S.S.	17	03-1406-01	Nut
4	A35453-001	End panel right, s-wood	18	15-0711-01	Emblem for s-wood
	A35453-015	End panel right, gray		15-0808-03	Emblem for S.S. or gray
	A35453-002	End panel right, S.S.	19	03-0721-00	Speed clip
5	A34038-001	Service panel, sandalwood	20	03-1404-12	Screw
	A34038-015	Service panel, gray	21	A32434-001	Base
	A34038-002	Service panel for S.S.	22	A32587-001	Upper brace, evap
6	A32452-003	Back panel, galv	23	A32467-001	Lower brace, evap
7	A35436-001	Utility panel	24	A32464-001	Screw, lower brace
8	02-2888-01	Back liner	25	A32469-001	Upper brace, cabinet
8a	A32458-002	Back insulation	26	02-3164-02	Air filter
9	02-2887-01	Right liner	27	A32511-001	Bin thermostat bracket
9a	A32458-004	Right insulation	28	03-0727-05	Bin thermostat thumb nut

# CME855A & CME1000A SERVICE PARTS

## Air Cooled Refrigeration

ITEM NUMBER	PART NUMBER	DESCRIPTION	ITEM NUMBER	PART NUMBER	DESCRIPTION
1	16-0876-001	Distributor and tubes	14		Compressors*
2	16-0875-001	Suction header		18-8749-22	CME855 208-230/60/1
3	02-3396-01	Insulation		18-8749-27	CME855 230/50 Hz
4	16-0878-21	TXV for 60 Hz models		18-8750-22	CME1000 208-230/60/1
	16-1022-21	TXV for 50 Hz models		18-8750-24	CME1000 208-230/60/3
5	A30296-020	Evaporator plate		18-8750-27	CME1000 230/50 Hz
6	16-0877-01	Defrost manifold	15	02-3319-02	Dryer
7	11-0493-21	Hot gas valve, CME855	16	18-8762-01	CME855 condenser
	11-0491-21	Hot gas valve, CME1000		18-8763-01	CME1000 condenser
8	12-2300-07	Hi temp cut out	* Compressors include a dryer.		
9	11-0479-21	Fan control			
10	11-0485-21	Hi pressure cut out			
11	16-0832-20	Access valve			
	16-0832-02	Stem cap			
	16-0832-03	Core cap			
12	18-2200-28	Grommet			
	18-2200-27	Sleeve			
13	03-1405-20	Screw			

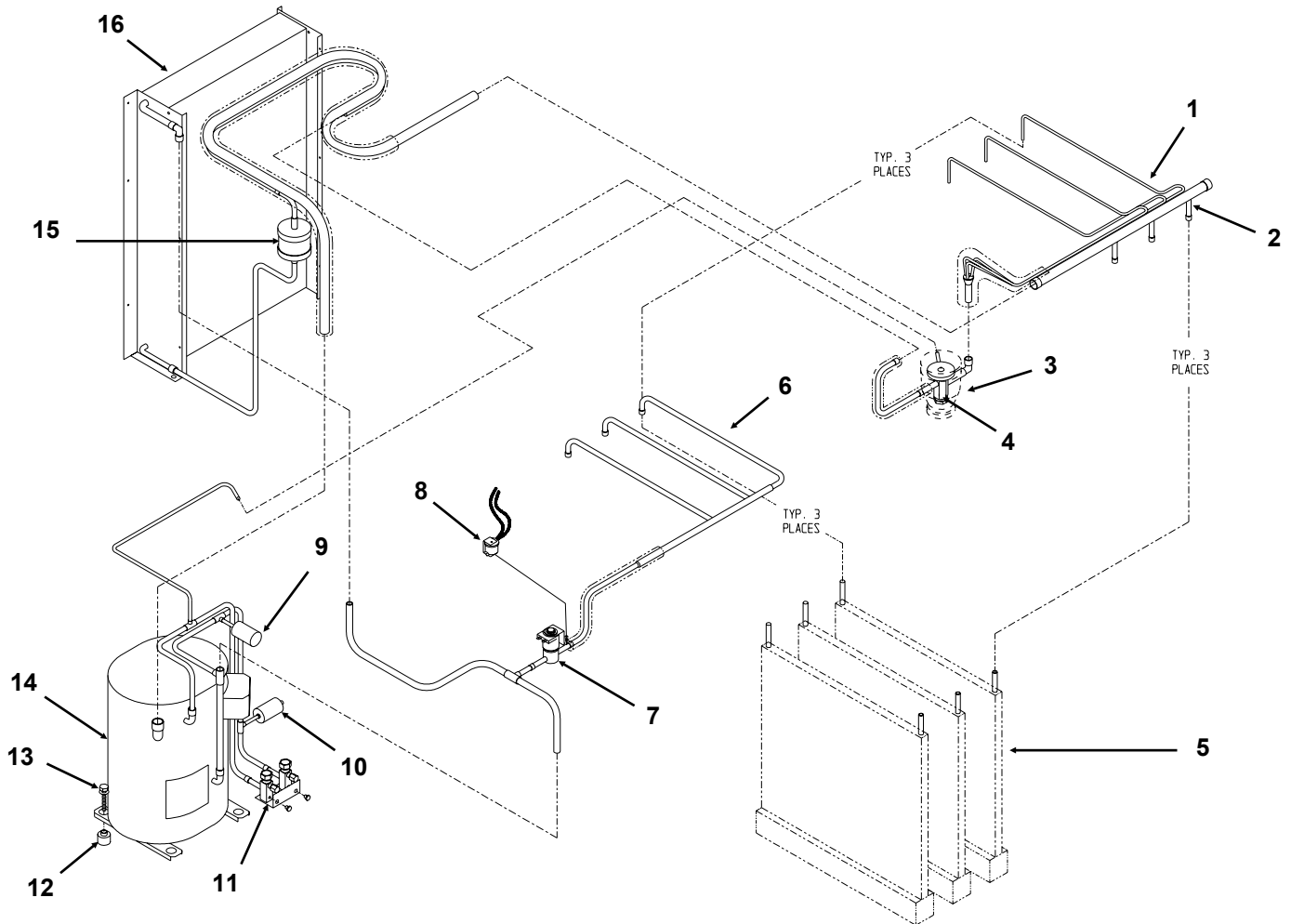

# CME855A & CME1000A SERVICE PARTS

## Fan Motor

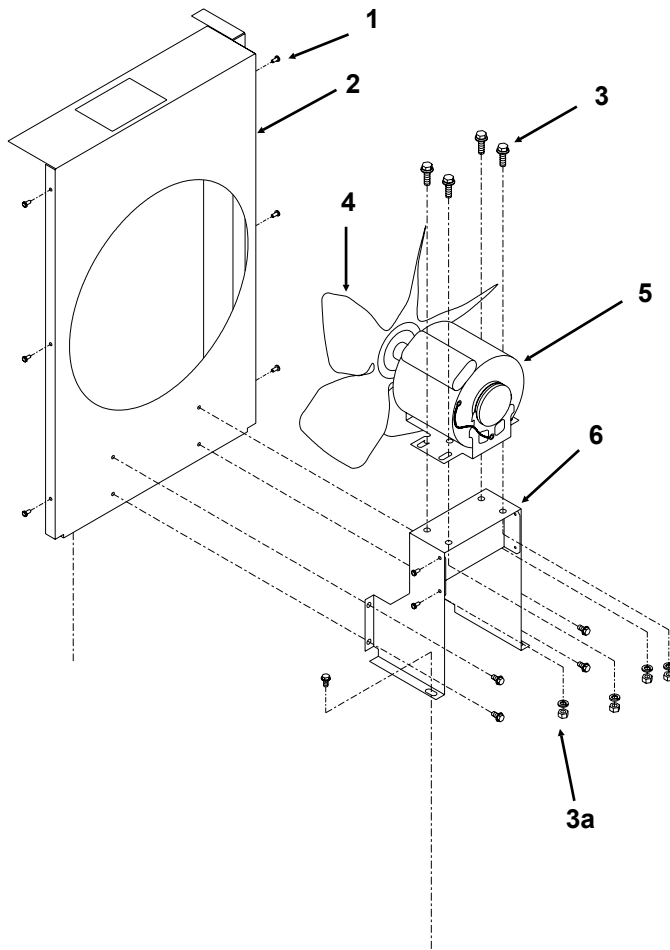

ITEM NUMBER	PART NUMBER	DESCRIPTION
1	03-1531-01	Screw
2	A36403-001	Fan shroud
3	03-1251-01	Hex bolt
3a	03-1406-10	Hex nut
4	18-8765-02	Fan blade
5	18-8764-01	Fan motor
6	A36397-001	Fan bracket

# CME855A & CME1000A SERVICE PARTS

## Water System

ITEM NUMBER	PART NUMBER	DESCRIPTION	ITEM NUMBER	PART NUMBER	DESCRIPTION
1	02-2527-01	Water Distributor Tube	15	03-1403-16	Screw
2	02-2521-01	Water Manifold, long	16	A34982-001	Drain fitting
3	13-0617-48	O-Ring	17	13-0796-01	Reservoir Drain Cap
4	A29703-001	Water Manifold, short	18	13-0617-02	O-ring
5	02-2895-01	Water Restrictor	19	13-0674-07	Drain hose (16.5" needed)
6	13-0674-07	Tube (need 30")	20	02-3094-01	Hose clamp
7	02-3094-01	Hose clamp	21	02-2606-01	Drain tube
8	02-2878-01	End cover	22	12-2446-26	Inlet water valve
9	02-2890-03	Evaporator Cover			
10	A35861-001	Reservoir, includes items 17, 21, 18,16,10			
11	03-1404-10	Screw			
12	13-0674-02	Hose (12" needed)			
13	12-2419-62	Water Pump			
14	A36308-001	Housing, pump			

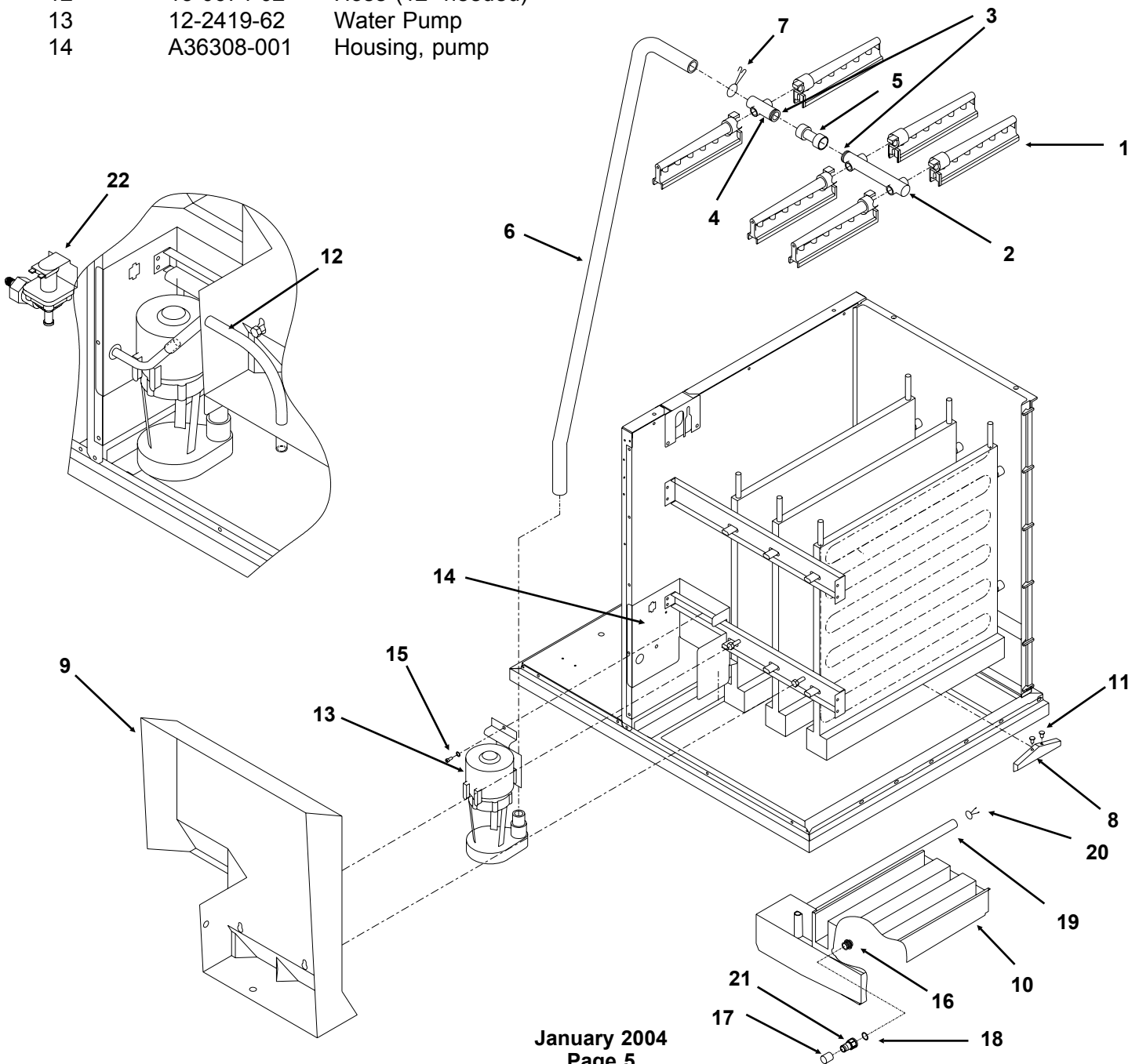

# CME855A & CME1000A SERVICE PARTS

## Control Box

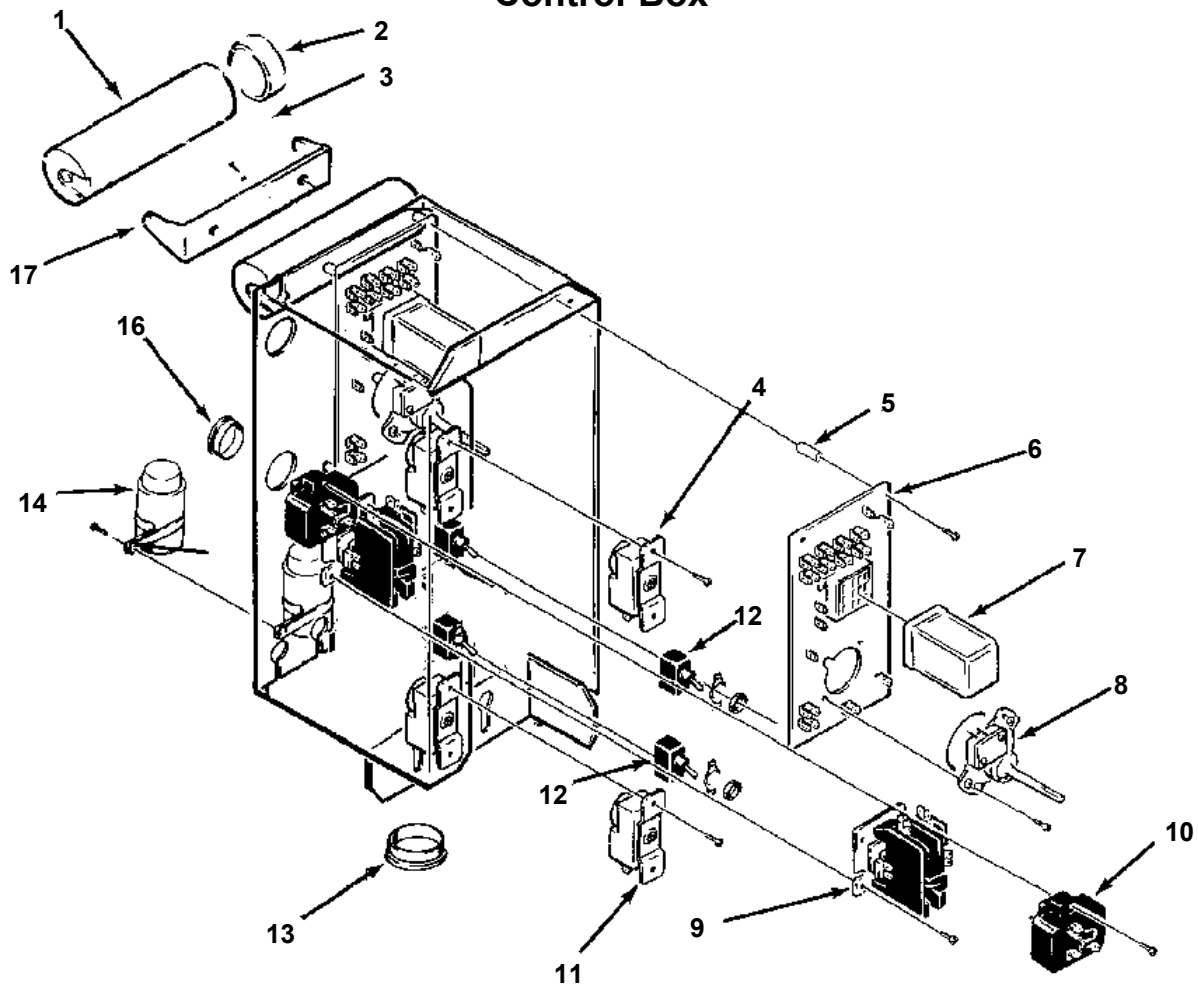

ITEM NUMBER	PART NUMBER	DESCRIPTION	ITEM NUMBER	PART NUMBER	DESCRIPTION
1	18-1901-48	Start Capacitor	13	12-2311-01	Snap bushing
2	18-2200-38	Start Capacitor Cap	14	18-1902-55	Run capacitor for all except CME1000 50 Hz
3	03-1419-06	Screw		18-1902-57	Run capacitor for CME1000 50 Hz
4	11-0436-21	Cube Size Control	15	02-2790-01	Snap Bushing
5	02-2242-02	Stand off	16	02-2790-01	Snap bushing
6	12-1912-01	Circuit board	17	18-2200-39	Bracket
7	12-1879-03	Relay	18	A31799-001	Control Box Cover
8	12-2107-22	Timer for 60 Hz			
	12-2107-26	Timer for 50 Hz			
9	12-2469-02	Contactor, single phase			
	12-0739-02	Contactor, three phase			
10	18-1903-46	Potential relay for all except CME855 50 Hz			
	18-1903-33	Potential relay for CME855 50 Hz			
11	11-0427-22	Bin Thermostat			
12	12-0426-01	Switch			

# CME855A & CME1000A SERVICE PARTS

## BH800 Ice Storage Bin

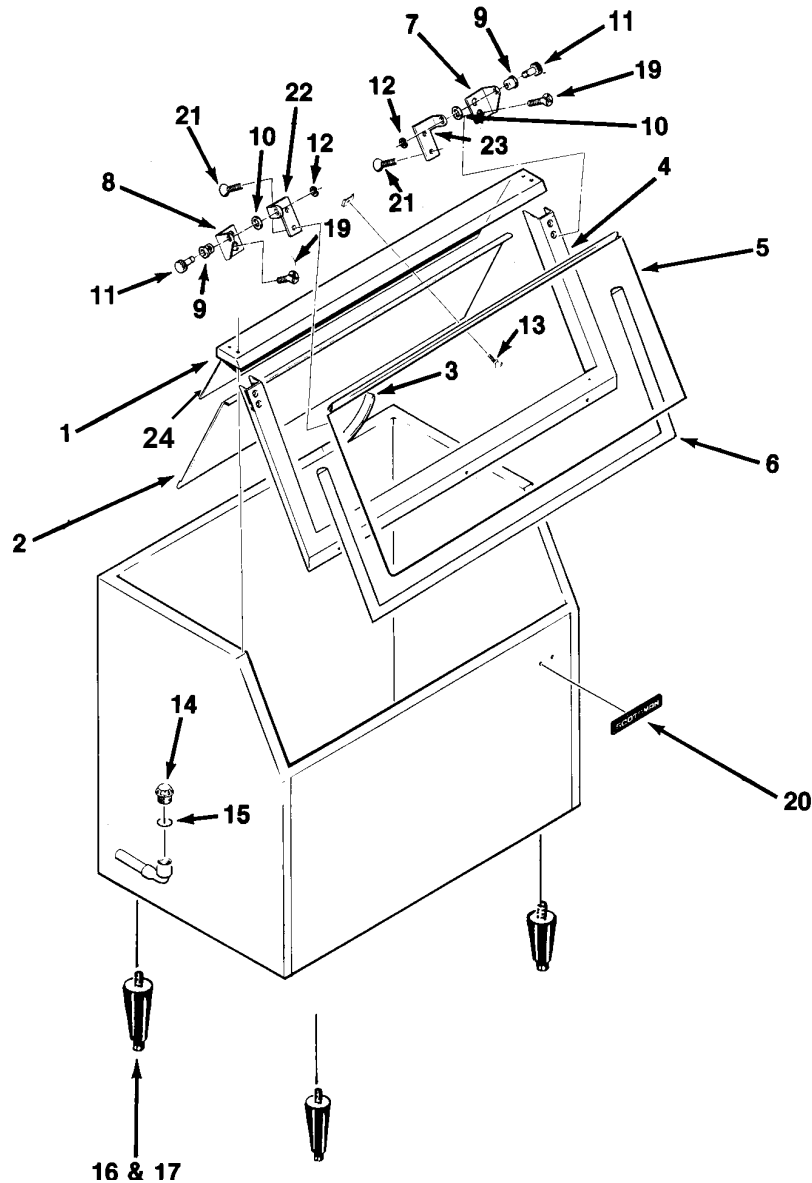

ITEM NUMBER	PART NUMBER	DESCRIPTION	ITEM NUMBER	PART NUMBER	DESCRIPTION
1	A32408-001	Canopy	13	03-0727-06	Thumb screw(for baffle)
2	A32410-001	Baffle	14	02-2809-01	Drain top
3	19-0503-04	Gasket, order per foot	15	13-0617-11	O-ring
4	A32418-020	Door frame	16	KLPE	Legs, for painted
5	A32419-020	Door	17	KLPS	Legs, for S.S.
6	13-0595-00	Door gasket, 10' req.	18	03-1404-06	Screw
7	A32396-002	Hinge, right	19	03-1360-02	Screw
8	A32396-001	Hinge, left	20	15-0711-01	Emblem for painted
9	02-2380-01	HInge bushing		15-0808-03	Emblem for stainless
10	02-2380-02	Hinge spacer	21	03-1418-41	Screw
11	02-2806-01	Shoulder screw	22	A32546-001	Door hinge, left
12	03-1539-09	E-Clip	23	A32546-002	Door hinge, right
			24	03-1423-07	Speed nut for baffle

# CME855A & CME1000A SERVICE PARTS

## Single Phase Wiring Diagram

A36923-001

USE COPPER CONDUCTORS ONLY

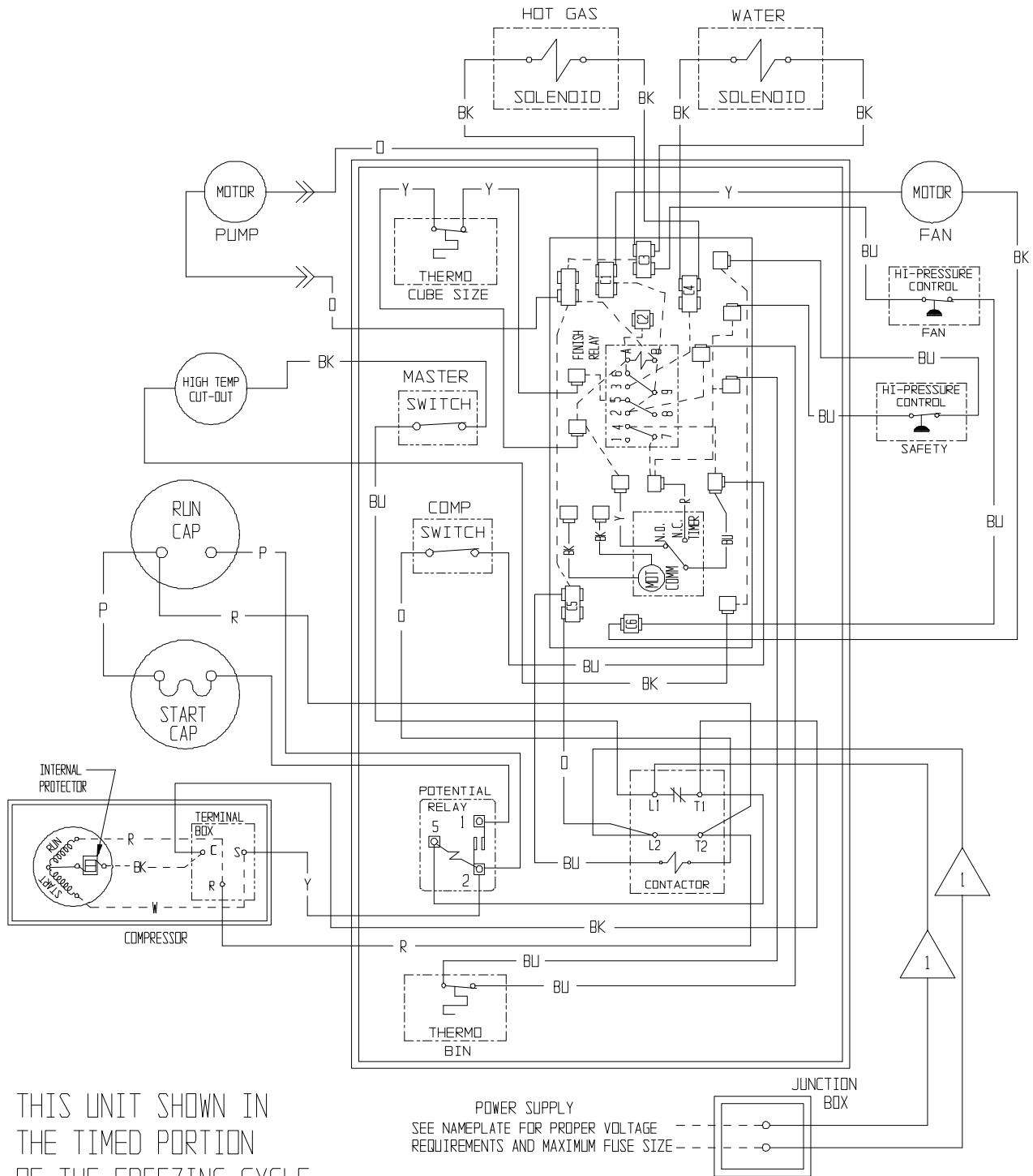

THIS UNIT SHOWN IN  
THE TIMED PORTION  
OF THE FREEZING CYCLE

NOTE:

⚠ WIRE COLOR FOR -32A (60 Hz) UNITS: BLACK  
WIRE COLOR FOR -6A (50 Hz) UNITS : BROWN



# CME855A & CME1000A SERVICE PARTS

## Single Phase Schematic Diagram

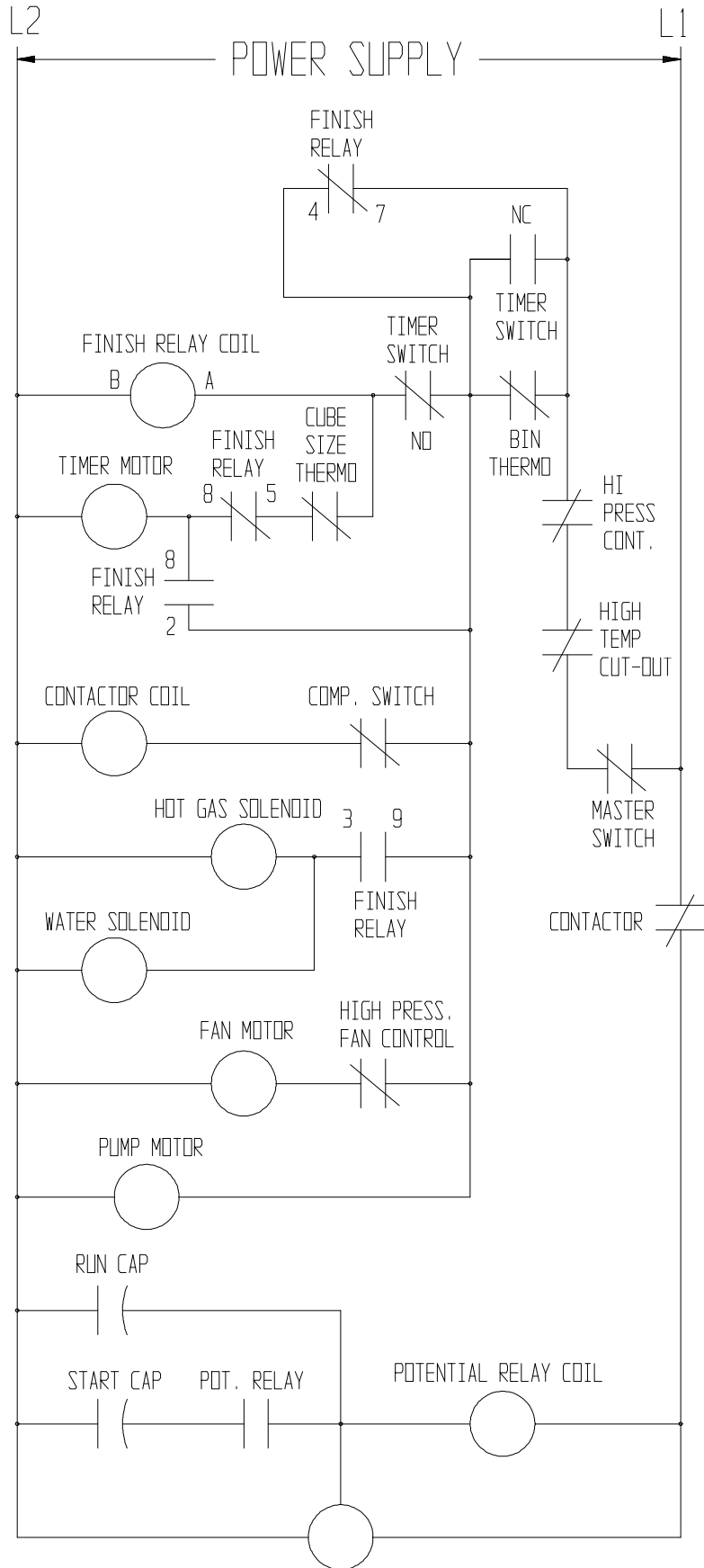

# CME855A & CME1000A SERVICE PARTS

## 3 Phase Wiring Diagram

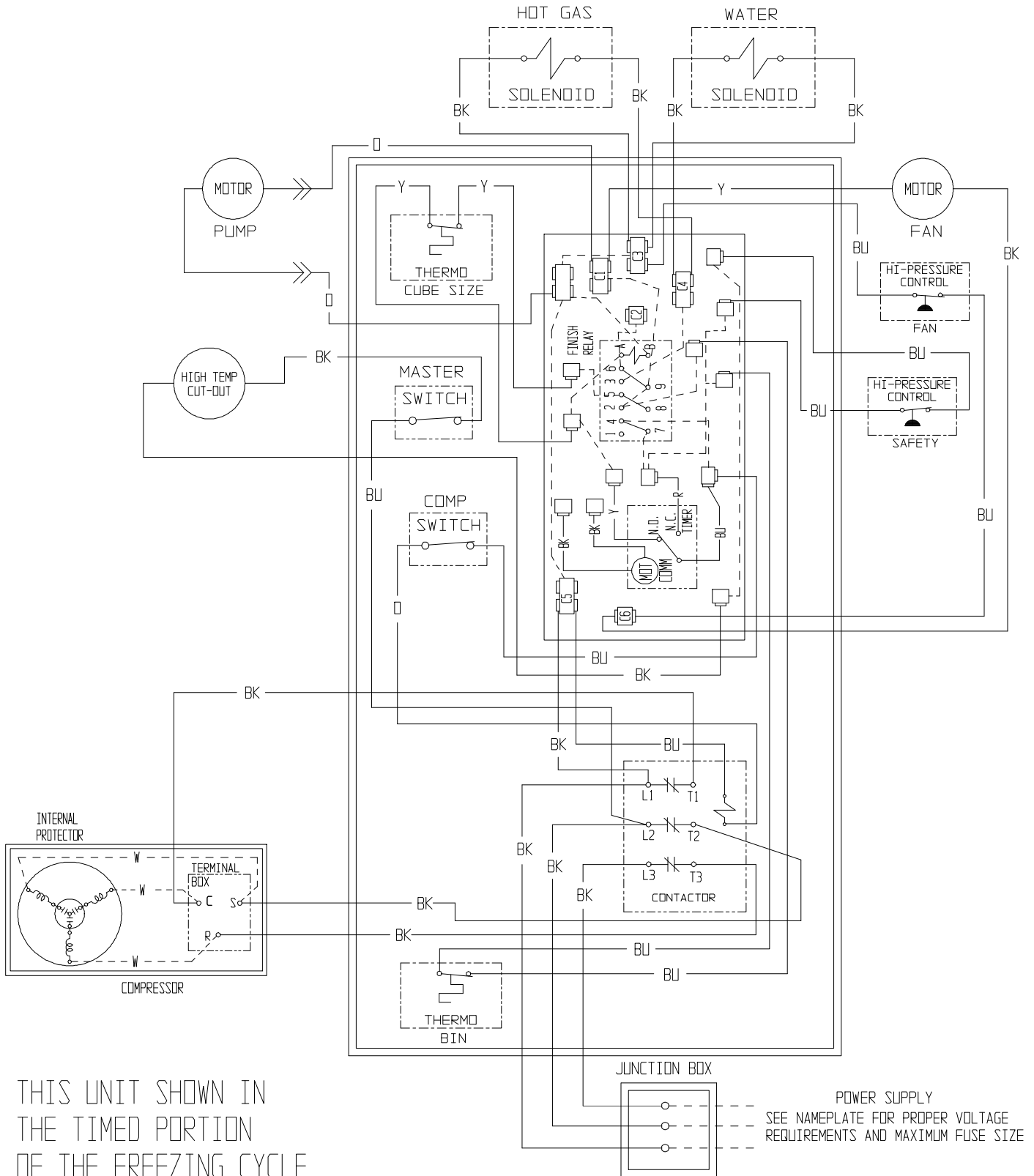

# CME855A & CME1000A SERVICE PARTS

## 3 Phase Schematic Diagram

