

## INTRODUCTION

---

This manual is intended as a reference for the installation of a Scotsman ice maker models CME855 and the CME1000.

## TABLE OF CONTENTS

SPECIFICATIONS . . . . .	page 2
UTILITY CONNECTION LOCATIONS . . . . .	page 3
FOR THE INSTALLER: Environmental Limitations . . . . .	page 4
FOR THE INSTALLER: Machine & Bin Assembly . . . . .	page 5
STACKING TWO UNITS . . . . .	page 6
FOR THE PLUMBER . . . . .	page 7
FOR THE ELECTRICIAN: Electrical Connections . . . . .	page 8
FOR THE INSTALLER: Final Check List . . . . .	page 9
INITIAL START UP . . . . .	page 10
ADJUSTMENT OF THE TIMER & SWITCH ASSEMBLY . . . . .	page 12
REFRIGERATION SYSTEM OPERATION . . . . .	page 13
WATER SYSTEM OPERATION . . . . .	page 14
COMPONENT DESCRIPTION . . . . .	page 15
SERVICE SPECIFICATIONS: CME855A . . . . .	page 17
SERVICE SPECIFICATIONS: CME1000A . . . . .	page 18
CLEANING . . . . .	page 19
SERVICE DIAGNOSIS . . . . .	page 21
REMOVAL AND REPLACEMENT . . . . .	page 23
REFRIGERATION SERVICE . . . . .	page 25
LIQUID CHARGING . . . . .	page 26

A Service Parts List and the Wiring Diagrams are located in the center of this manual, printed on yellow paper.

# CME855A & CME1000A SPECIFICATIONS

Always refer to the nameplate, located on the back of the cabinet, for the:

- model number,
- serial number,
- basic electrical requirements,
- minimum circuit ampacity,
- maximum fuse size,
- and refrigerant charge.

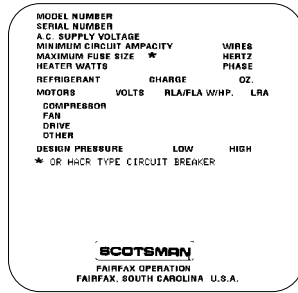

Serial Number  
Plate Behind  
Front Panel

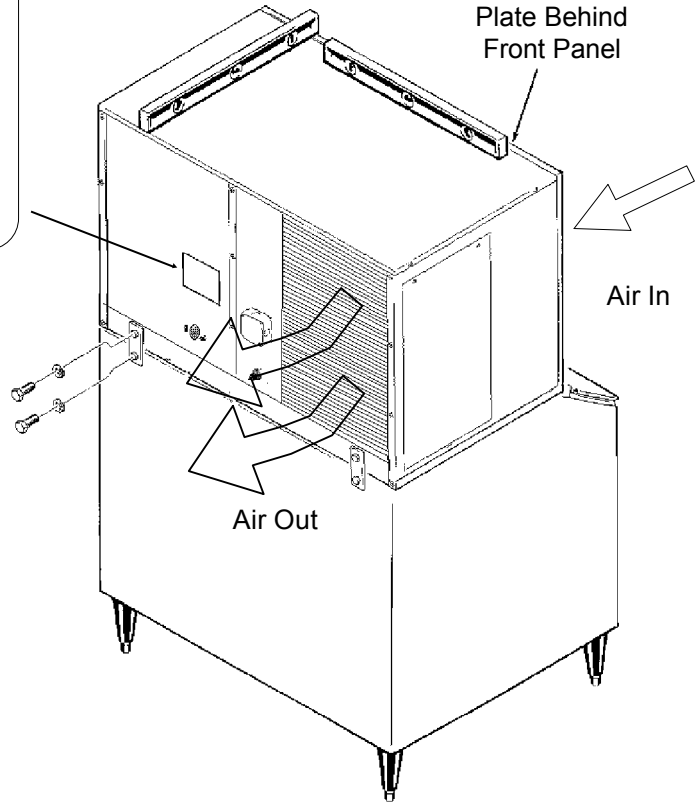

A serial number plate with the model number, serial number and refrigerant charge is located behind the front panel, near the control box.

The unit comes from the factory with the correct refrigerant charge. The refrigerant charge information is for recharging, should that be necessary.

All utility connections are made at the back of the ice maker.

Before beginning installation, be sure that all of the components necessary for complete assembly of the ice system are available, and are the correct components with regard to model, voltage, and finish.

The CME855 or CME1000 will fit Scotsman bin BH800 without needing a bin top. Other bins will require a bin top.

Model Number	Dimensions W" x D" x H"	Basic Electrical	Refrigerant Type	Min. Circ. Amps	Max. Fuse** Size	Refrigerant Charge*
CME855AE-32A	42 x 24 x 27	208-230/60/1	R-404A	15.9	20	36 ounces
CME855AE-6A	42 x 24 x 27	230/50/1	R-404A			36 ounces
CME1000AE-32A	42 x 24 x 27	208-230/60/1	R-404A	19.9	20	42 ounces
CME1000AE-3A	42 x 24 x 27	208-230/60/3	R-404A	13.8	15	42 ounces
CME1000AE-6A	42 x 24 x 27	230/50/1	R-404A			42 ounces

\* The system charge is in the machine. This number is for recharging purposes only. If the nameplate has a different value, go by the nameplate. \*\* Or HACR type circuit breakers.

	Air Temperature	Water Temperature	Voltage
Minimum	50 <sup>0</sup> F.	40 <sup>0</sup> F.	-5%
Maximum	100 <sup>0</sup> F.	100 <sup>0</sup> F.	+10%

## UTILITY CONNECTION LOCATIONS

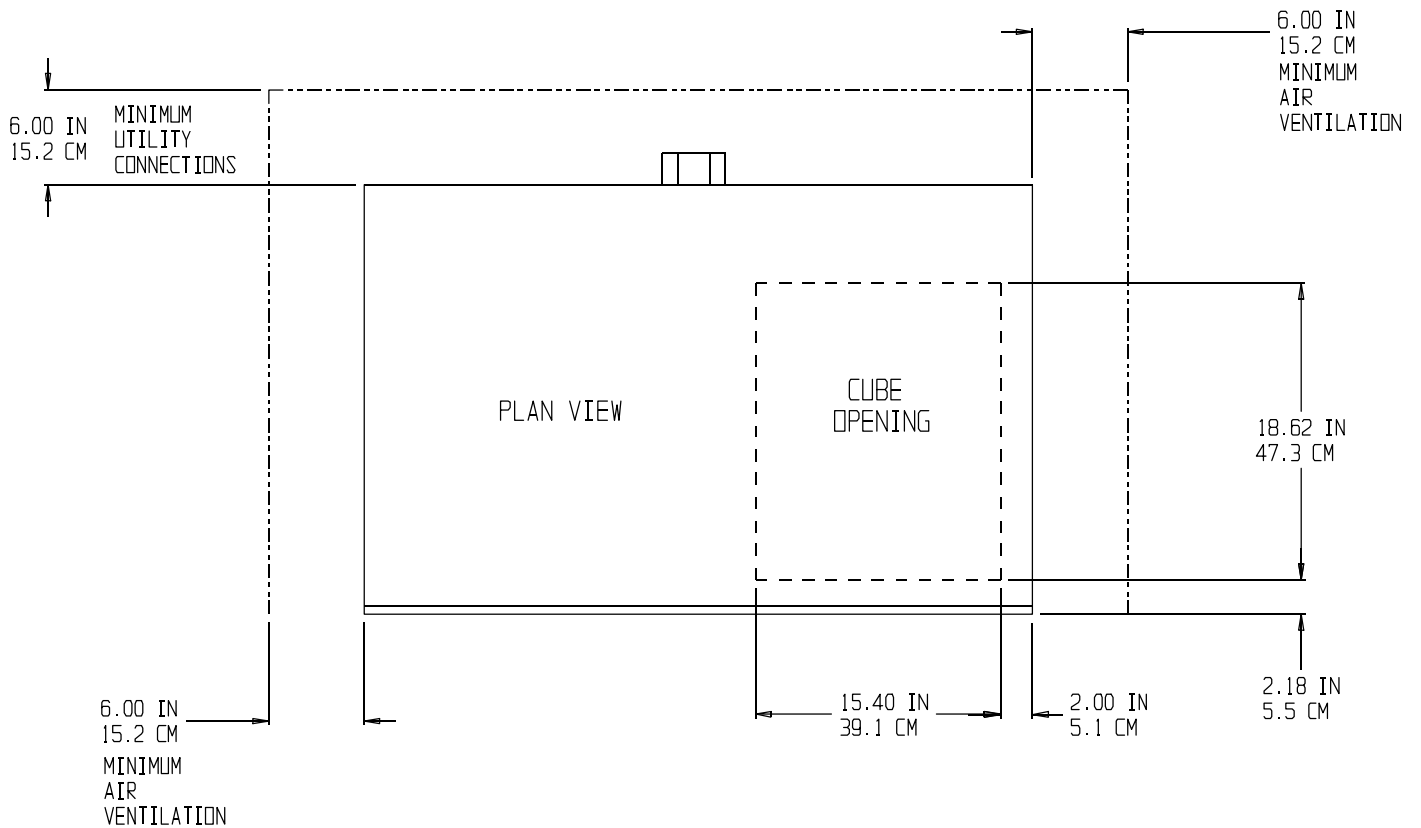
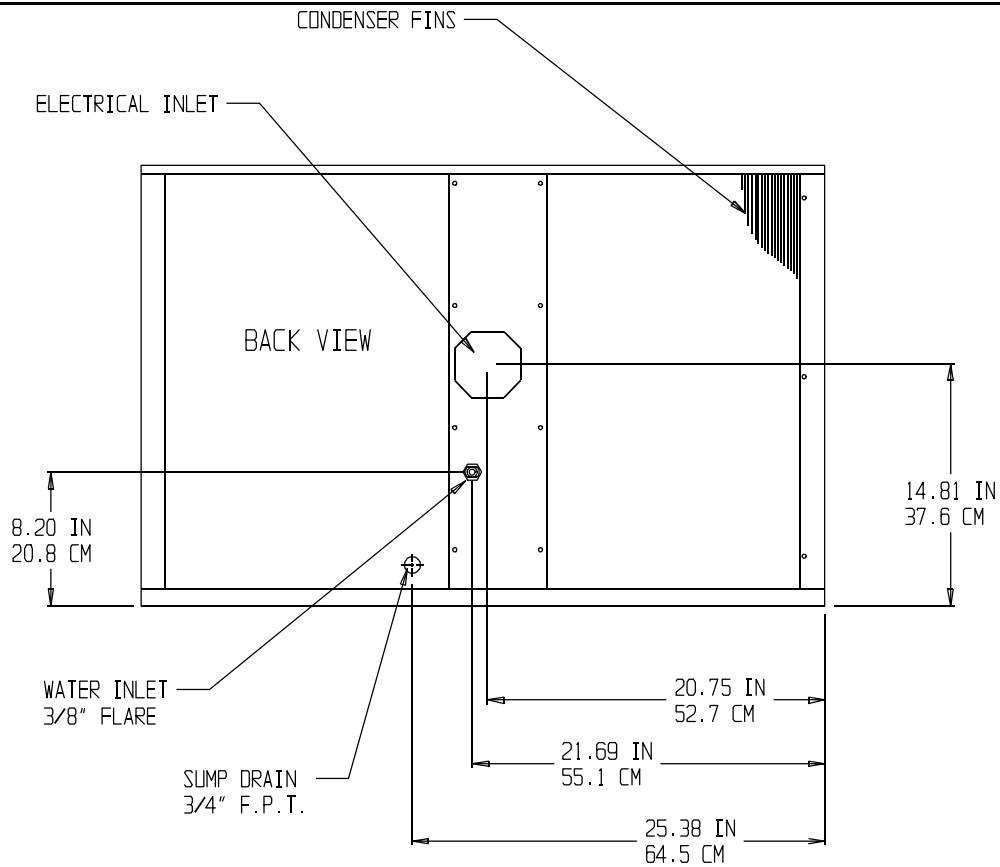

# CME855A & CME1000A

## FOR THE INSTALLER: Environmental Limitations

---

### Installation Limitations

The ice making portion of this ice system is designed to be installed indoors, in a controlled environment.

	Minimum	Maximum
Air Temp	50 <sup>0</sup> F.	100 <sup>0</sup> F.
Water Temp	40 <sup>0</sup> F.	100 <sup>0</sup> F.
Water Pressure	20 PSI	80 PSI
Voltage	197	253

Operating the ice machine outside of the above limitations, or outdoors, is potentially damaging to the machine; also it is misuse of the machine, which may void the warranty.

Scotsman Ice Systems are designed and manufactured with the highest regard for safety and performance. They meet or exceed the standards of UL, NSF, and CUL.

Scotsman assumes no liability or responsibility of any kind for products manufactured by Scotsman that have been altered in any way, including the use of any part and/or other components not specifically approved by Scotsman.

Scotsman reserves the right to make design changes and/or improvements at any time.

Specifications and design are subject to change without notice.

### Water Limitations

An ice machine is a food manufacturing plant; it takes a raw material, water, and turns it into a food product, ice. The purity of the water is very important in obtaining pure ice and in maximizing product life. These general recommendations should help keep the ice maker clean:

1. Filter the water used to produce ice. Water filters vary greatly in ability and function. Install one that filters out suspended solids to a dimension of 5 microns or smaller. The finer the filter the better, but finer filters will clog sooner than course ones. It may be necessary to add a course filter ahead of the fine filter to prolong filter life.

2. Check with a water treatment specialist for a water test, and recommendations regarding filters and treatment.

### Service Limitations

Some space on the sides, the back and the top should be allowed for service and utility connections.

# CME855A & CME1000A

## FOR THE INSTALLER: Machine & Bin Assembly

### Storage Bin:

After uncrating the ice storage bin, attach the legs to the bin:

1. Use a portion of the carton as a cushion, and tip the storage bin on its back.
2. Screw the legs into the threaded holes in the bottom of the bin.
3. Turn the leg levelers all the way in to prepare the bin and ice machine for leveling.
4. Return the bin to the upright position.

### Ice Maker:

1. Arrange for proper electric, water and drain.

See instructions for the plumber and for the electrician.

2. Position the ice storage bin in the selected INDOOR location.
3. Level the bin, in both the front to rear and side to side directions.
4. Inspect the bin top mounting gasket which should be flat, with no wrinkles, to provide a good water seal when the cuber is installed on top of the bin.
5. Install the modular cuber on top of the bin using care to be sure a good seal is made between the two cabinets, use of a mechanical lift is recommended. Align the holes in the bottom back of the cabinet to mate with the two mounting straps on the top rear of the bin.
6. Use bolts and straps found in the hardware package to secure the ice machine to the ice storage bin. When alignment and leveling are completed, tighten the bolts to secure the mounting straps.
7. Install the bin thermostat bracket. The bracket is shipped in a cardboard container located in front of the freezing compartment.

Mount the bracket to the bottom of the ice machine with the plastic tube inserted up thru the ice machine base from below. Secure the bracket to the ice machine base using 3 thumbscrews from the hardware package.

Uncoil the bin thermostat cap tube and insert it into the plastic tubing of the bracket to the end of the metal tubing.

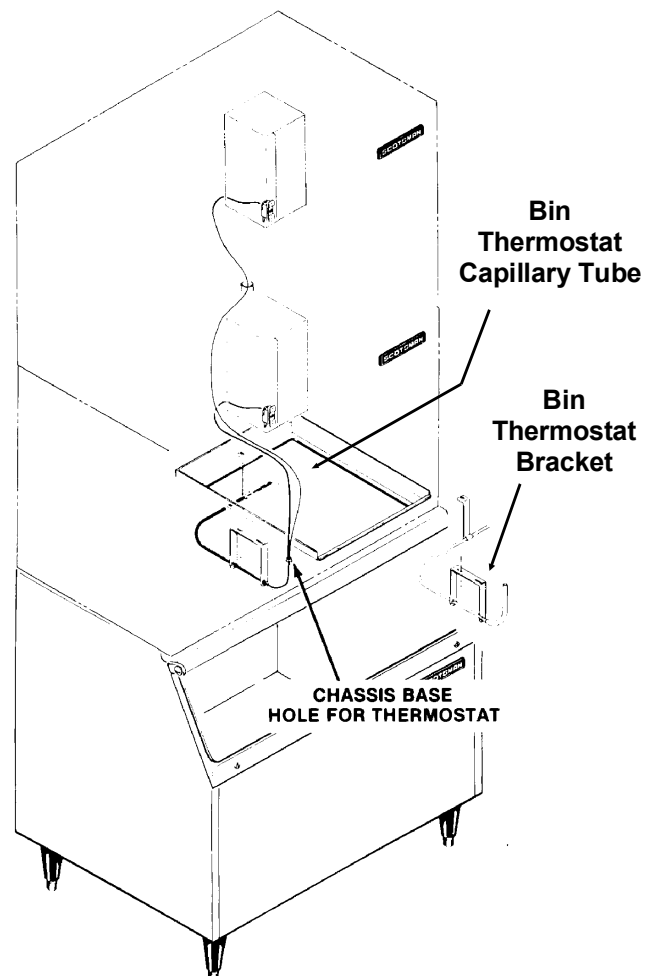
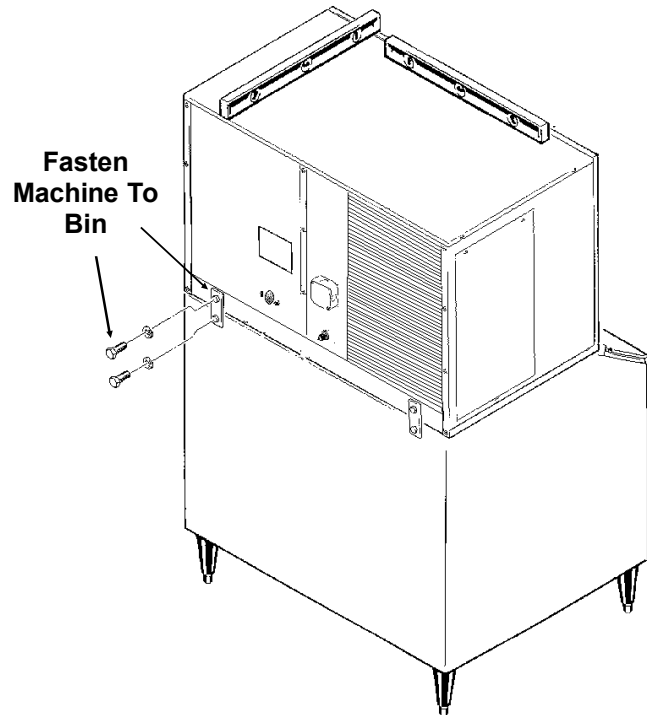

# CME855A & CME1000A

## STACKING TWO UNITS

---

To stack a 42" wide CME cuber onto a CME855A, CME1000A, CM855 or CM1000 cuber:

A Heavy Duty Leg Kit is Recommended.

1. Remove the top panel from the lower unit.
2. Add a bead of food grade sealant (such as Scotsman part number 19-0529-01) to the top edges of the lower unit's freezing compartment.
3. Lift the top unit onto the bottom machine (a mechanical lift is recommended).
4. Align the two machine's cabinets, and using the bolts and straps from the hardware package, fasten the two units together at the back.

Note: When placing a new unit on a CM855 or CM1000, the outboard (right side viewed from the back) threaded holes should be used.

5. Route the bin thermostat capillary tube from the upper machine into the lower machine and into the bin thermostat bracket, next to the capillary tube from the lower machine.

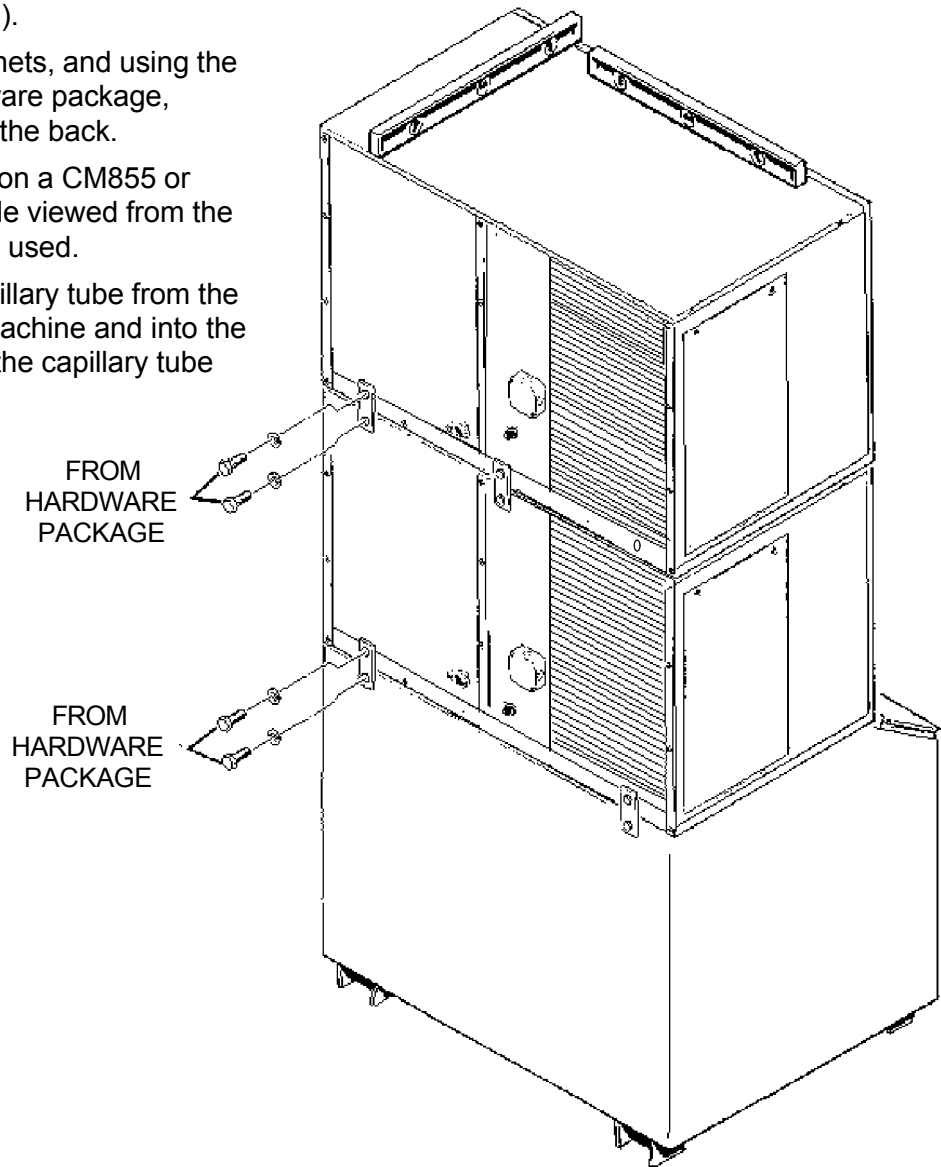

STACKING TWO CME 42" AIR COOLED

## FOR THE PLUMBER

### Water Supply

The recommended water supply line is a 3/8-inch O.D. tubing with a minimum operating pressure of 20 PSIG and a maximum of 80 PSIG.

A separate water inlet is required for the condenser water supply.

Connect to cold water supply line with standard plumbing fittings, with shut off valve installed in an accessible place between the water supply and the cuber. In some cases a plumber will be required.

CONFORM TO ALL LOCAL CODES

### Drain Connections:

Connections: All drains are gravity type and must have a minimum of 1/4 - inch fall per foot of horizontal run. The drains to be installed must conform with the local plumbing codes. Install a vertical open vent on the ice machine reservoir drain. The ideal drain receptacle is a trapped and vented floor drain. The storage bin drain should be insulated.

### PLUMBING CONNECTIONS

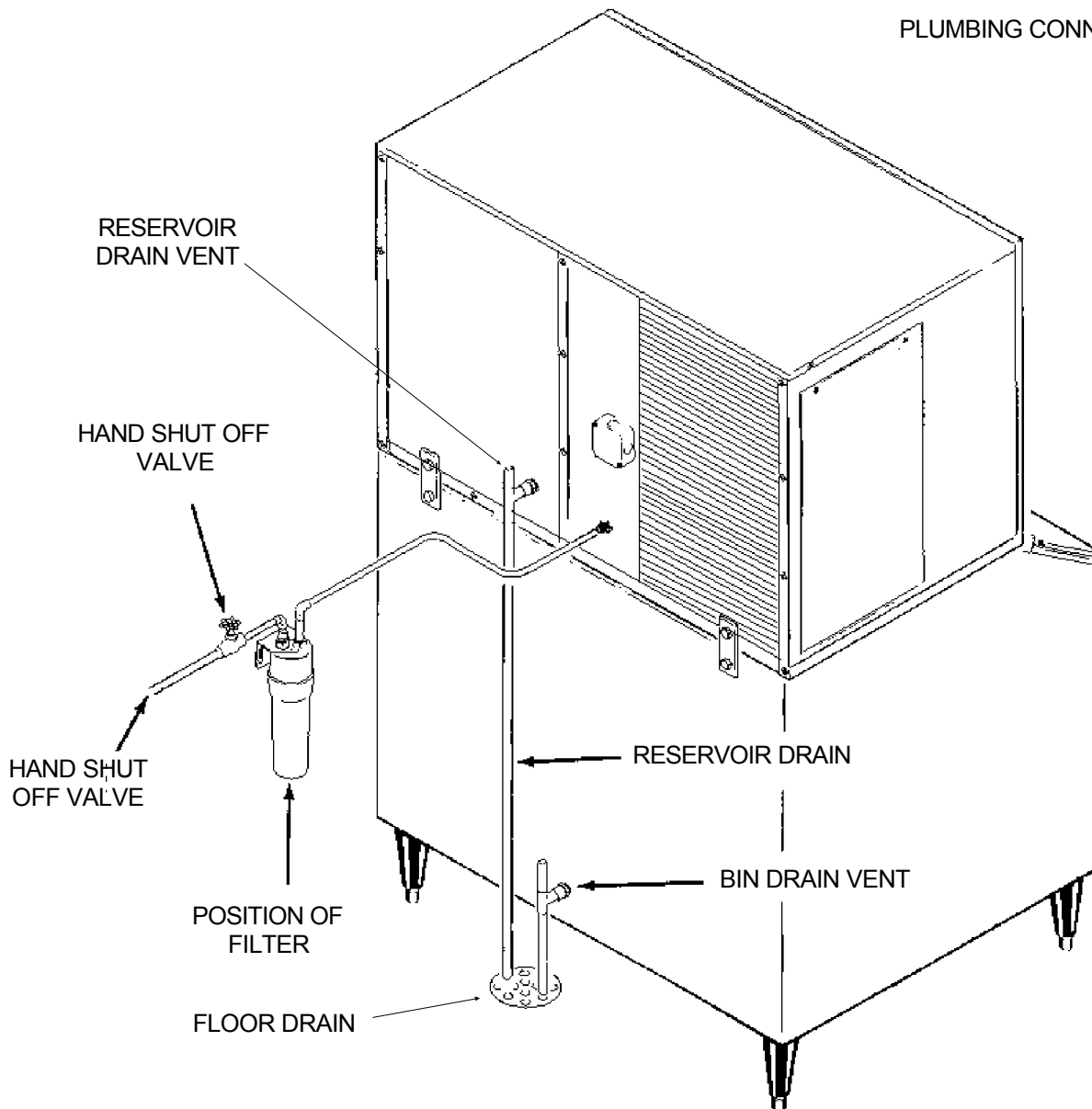

# CME855A & CME1000A

## FOR THE ELECTRICIAN: Electrical Connections

---

See the NAMEPLATE for current requirements to determine wire size to be used for electrical hookup. The cuber requires a solid chassis to chassis earth ground wire. See Wiring Diagram.

Be certain the cuber is connected to its own electrical circuit and individually fused. Voltage variation should not exceed ten percent of the nameplate rating, even under starting conditions. Low voltages can cause erratic operation and may be responsible for serious damage to the ice maker.

Electrical connections are made at the rear of the ice maker, inside the junction box.

**All external wiring should conform to the national, state and local electrical code requirements. Usually an electrical permit and services of a licensed electrician will be required.**

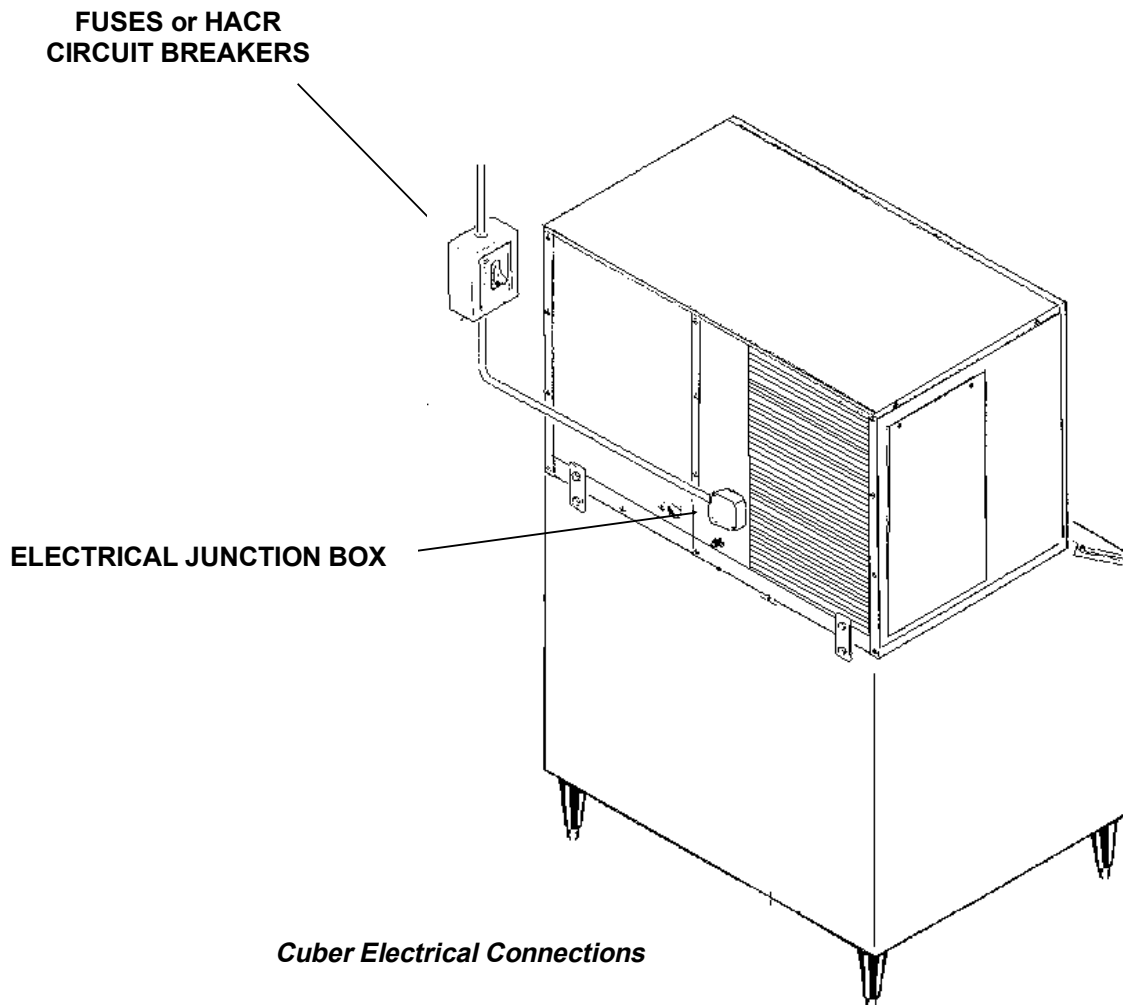



## FOR THE INSTALLER: Final Check List

1. Is the ice maker cabinet in a room where ambient temperatures are within the minimum and maximum temperatures specified?
2. Is there clearance at the left side of the cabinet and at the back and top for service and utility connections?
3. Has water supply pressure been checked to insure a minimum of 20 PSIG and a maximum of 80 PSIG operating pressure?
4. Is the cabinet level?
5. Check that any shipping material has been removed from inside the cabinet.
6. Have all electrical and piping connections been made?
7. Are the Master and Compressor switches on OFF?
8. Has power been connected to the ice maker?
9. Is the water supply line shut off valve installed?
10. Check all refrigerant lines and conduit lines, to guard against vibration or rubbing and possible failure.
11. Have the bin and cabinet been wiped clean and sanitized?
12. Has the Customer Evaluation and Warranty Registration form been properly filled out? Check for correct model and serial numbers from Serial nameplate, then mail the completed form to SCOTSMAN.
13. Has the owner been given the name and telephone number of the authorized SCOTSMAN Service Agency serving him?

Final Check List

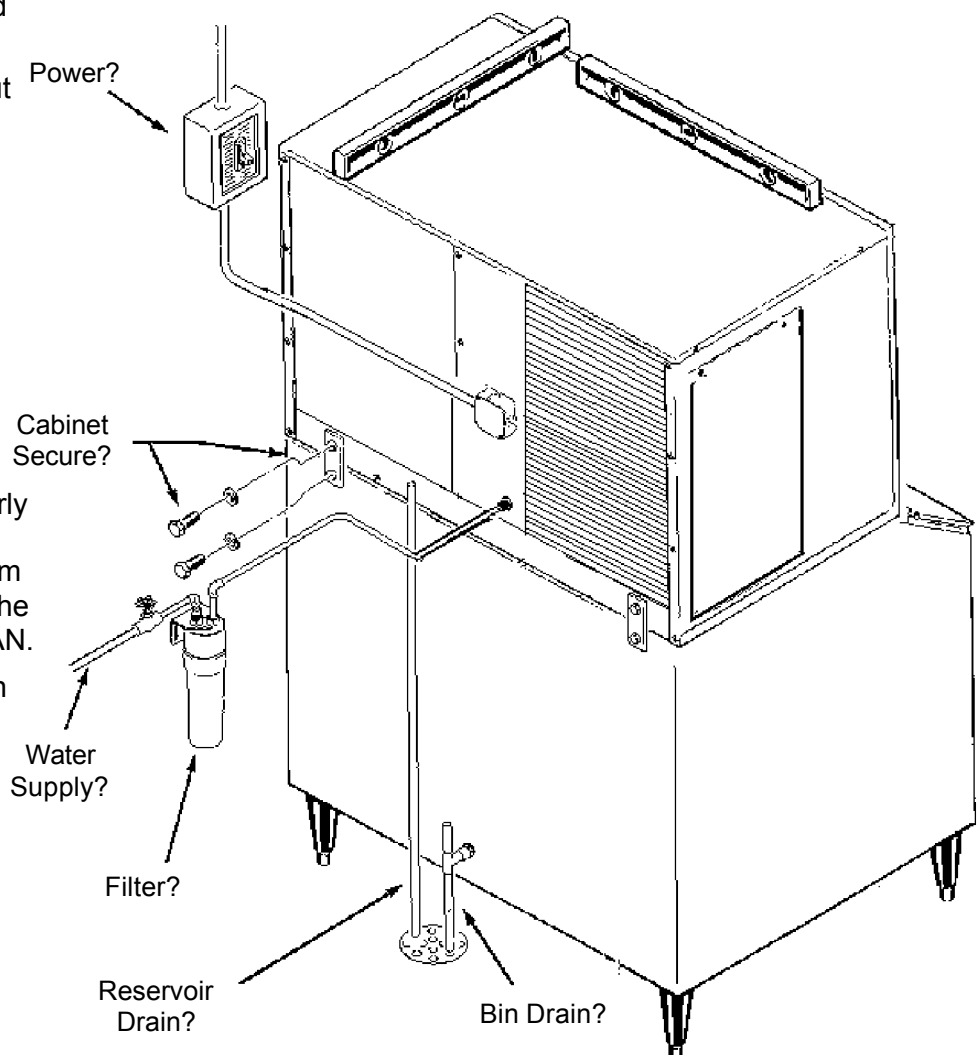

# CME855A & CME1000A

## INITIAL START UP

---

Ice Maker:

1. Remove screws and front panel.
2. Remove two screws and the control box cover.
3. Remove the evaporator cover.
4. Locate two toggle switches on the front of the control box. Check that the Master ON/OFF switch and the Compressor ON-OFF switch are in the OFF position.
5. OPEN the water supply line shut off valve.
6. Inside the control box is the shaft of the timer and the switch assembly. Rotate the shaft of the timer and switch assembly clockwise to where the actuator arm on the microswitch drops off outer cam into cam slot. See Timer Cam Positions.
7. Move the Master ON/OFF switch to the ON position.

TIMER CAM POSITIONS

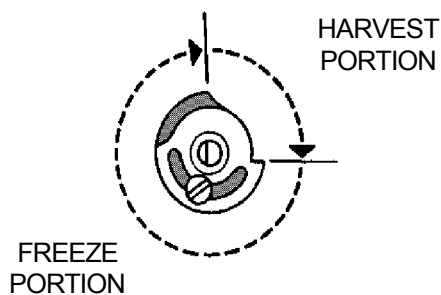
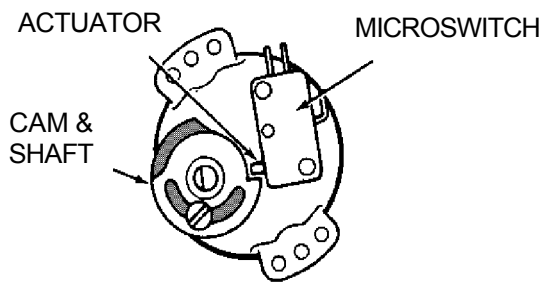

8. Observe water fill cycle: Water pump operates and water inlet solenoid valve OPENS, incoming water flows from the valve through the tubing, the reservoir fills and excess water drains out the reservoir drain. At the end of the harvest cycle, the water inlet solenoid valve will close and the water fill cycle is complete. If the reservoir is not full, advance the shaft of the timer clockwise into a new harvest cycle; this opens the water valve again.
9. Check that the water cascades down over each cube mold and into the reservoir.
10. When the reservoir is full, move the compressor ON-OFF switch, to the ON position.
11. Check operation of the freezing cycle: The compressor is operating. The ice making process begins; feeling the metal parts of the evaporator plate reveals cold temperature, very shortly ice begins to form. Tubing will become frosted at the top of the evaporator plate. After the first cycle, freezing time will range between 10 and 17 minutes.

In moderate temperatures, CME855 average complete cycle time is about 15 minutes, and CME1000 average complete cycle time is about 12 minutes.

### 12. Check CUBE SIZE

The dimensions of the cubes are fixed by the size and shape of the molds on the evaporator plate, except that the thickness of the cube MAY need to be adjusted at start up. There is only one size of cube that is correct; adjusting the cube size control to that size of cube will allow the ice maker to produce ice at its most efficient size. The correct size cubes will be fully formed at the edges; will harvest off of the evaporators beginning with individual cubes at the top of the evaporator, then vertical strips for the balance; and will appear similar to the illustration for "Correct Size Cube".

## INITIAL START UP

Adjust for the correct size if needed:

To produce SMALLER sized ice cubes:

Locate cube size control knob in the front of the control box. Rotate this knob one eighth of a turn counter clockwise. Observe size of the ice cubes in the next ice cube harvest and adjust again if needed, until the correct ice cube is achieved.

To produce LARGER ice cubes:

Locate cube size control on the front of the control box. Rotate the knob one eighth of a turn clockwise. Observe size of ice cubes in the next cube harvest and adjust again if needed, until correct the ice cube size is achieved.

13. Check Harvest Time. The machine must harvest all cubes before returning to a freeze cycle.

Increase the harvest time if there is less than 15 seconds of harvest time after the last cube has fallen into the bin.

Decrease the harvest time if there is much more than 15 seconds of harvest time after the last cube has fallen into the bin. Note: Harvest time is dependent upon the water and air temperatures at the ice machine. Do not adjust harvest time too short, as this will cause a freeze up.

See the next page for detailed harvest time adjustment instructions.

### 14. Check BIN THERMOSTAT

With the ice maker in the harvest cycle, hold ice against the metal tube of the bin thermostat bracket. The ice machine will shut off only at the end of the harvest cycle.

Remove the ice and within a few minutes the ice machine should restart.

15. Replace all panels, the machine is ready for automatic operation.

16. Fill out and mail in the Customer Evaluation and Warranty Registration Form.

Explain to the user the specifications, operation and maintenance requirements of the ice machine.

Inform the user of the name and telephone number of the local service contact.

### CUBES (ACTUAL SIZE)

TOO THICK

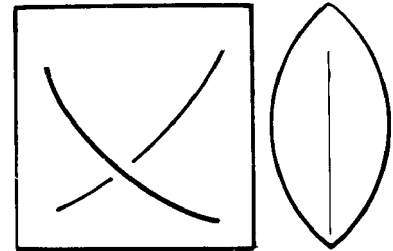

CORRECT SIZE CUBE

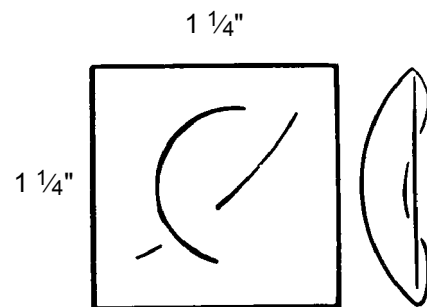

Note: Optimum performance will be achieved when the ice machine is adjusted to produce this size and shape of cube. The typical batch weight at this setting is between 8.25 and 9 pounds.

TOO THIN

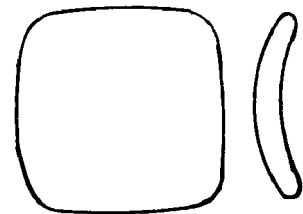

# CME855A & CME1000A

## ADJUSTMENT OF THE TIMER & SWITCH ASSEMBLY

One complete revolution of the cam on the timer represents eight minutes. If left as factory set, the timed freeze cycle will be 5 minutes 15 seconds, and the harvest cycle will be 2 minutes 45 seconds. Rotating the shaft of the timer cam Clockwise will put the ice machine into the freeze or harvest cycle.

### WARNING

-----  
Disconnect electrical power supply to ice maker whenever adjustment procedures are performed.  
-----

To adjust the timer & switch assembly:

1. Remove front panel.
2. Remove control box cover.
  - A. To start the HARVEST CYCLE: Slowly rotate the shaft of the timer and switch assembly, clockwise until the actuator arm on the microswitch initiates the harvest cycle. An audible click can be heard, but in a noisy area, look at the cam and switch to observe the event
  - B. To start the FREEZING CYCLE: Slowly rotate the shaft of the timer and switch assembly clockwise until the actuator arm on the microswitch initiates the freezing cycle.
  - C. To adjust the length of the harvest cycle:
    1. Loosen the adjustment screw on the cam and rotate the shaft of the cam to move the cam. More of a gap between the high and low portions will yield more harvest time.
    2. Tighten the set screw.
  3. Replace the control box cover and front panel.

It is important that the length of the harvest cycle allow enough time for all the ice cubes to fall from the evaporator. Too short of a time will cause the evaporator to freeze up and stop ejecting ice into the bin. Too much time wastes ice making capacity, energy and water. Adjustment of the harvest cycle may require an adjustment of the cube size control.

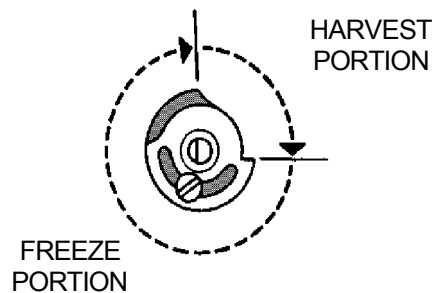
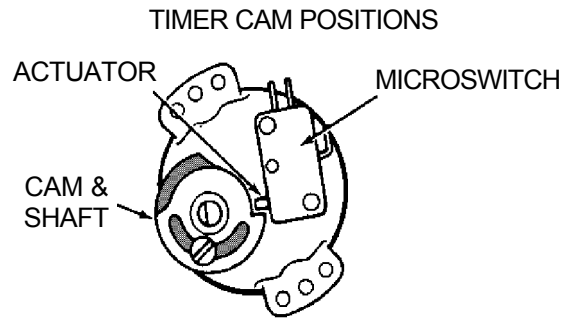

### TIMER ADJUSTMENT

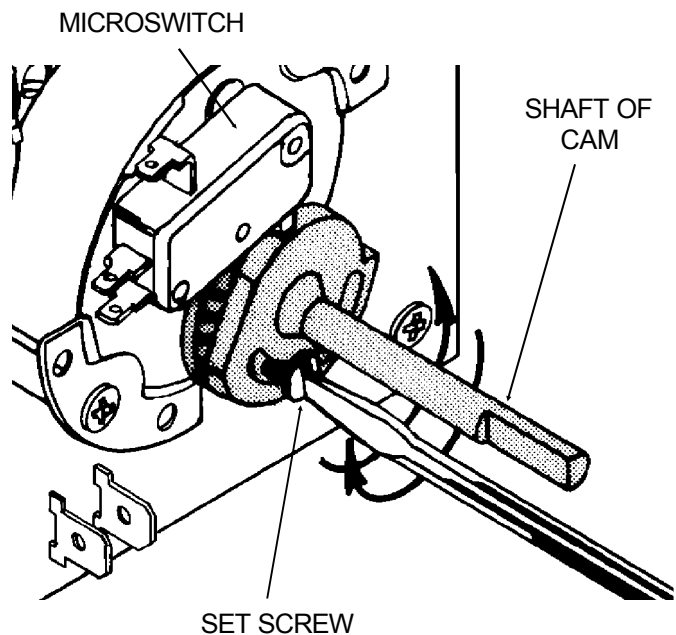

## REFRIGERATION SYSTEM OPERATION

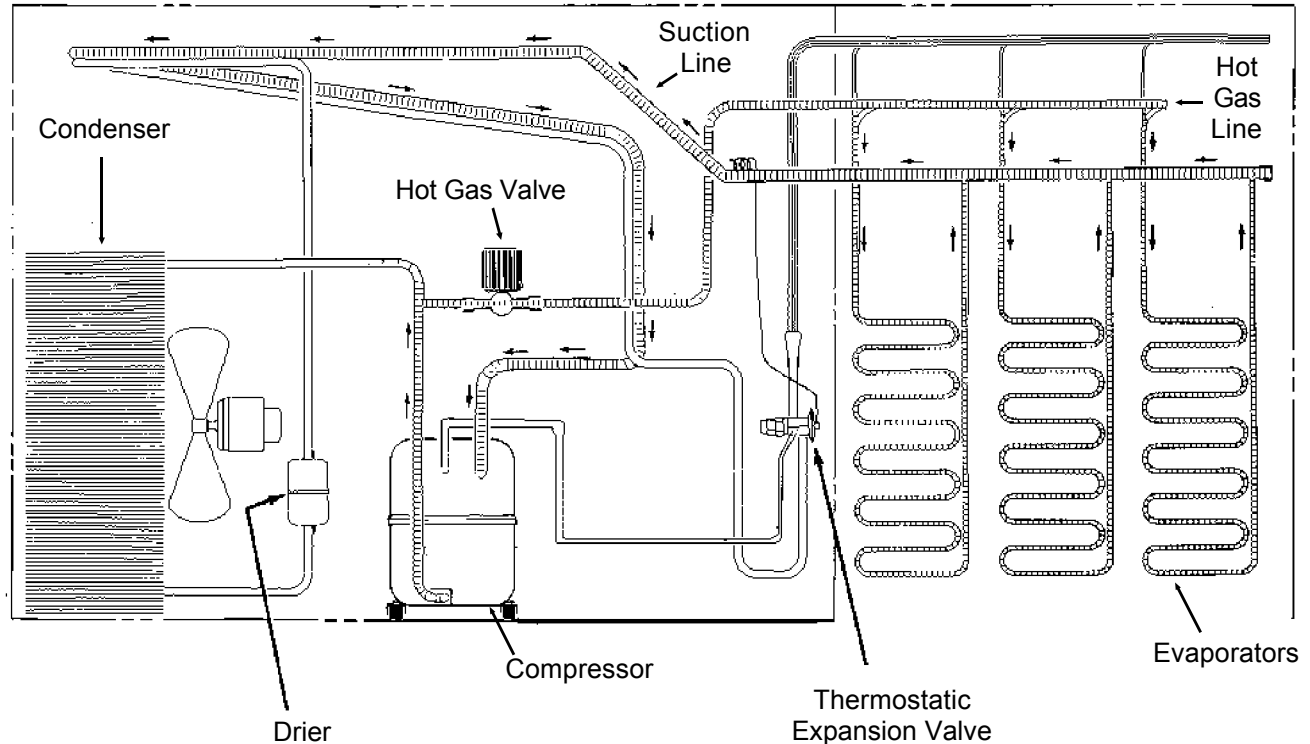

Refrigeration System Schematic

## FREEZE CYCLE

The compressor forces the refrigerant into the discharge tube. The refrigerant, now a very hot, high pressure gas flows to the condenser. At the condenser the refrigerant's heat is transferred to the air blowing thru the condenser. The refrigerant changes from a gas to a liquid.

After the condenser, the now liquid refrigerant flows thru the thermostatic expansion valve. The thermostatic expansion valve liquid refrigerant thru the refrigerant distributor and into the three evaporators.

Inside the evaporators, the liquid refrigerant rapidly expands, because it has moved from a high pressure zone to one of much lower pressure. The heat from the water going over the evaporators keeps the refrigerant expanding, and the refrigerant absorbs this heat. This causes the evaporators and the water going over them to loose heat.

The refrigerant then flows into the suction line and back to the compressor.

## HARVEST CYCLE

The only change between freeze and harvest is that a valve opens a path between the discharge line and the evaporator inlet. This valve is called the Hot Gas Valve. It allows hot discharge refrigerant gas to flow directly from the compressor to the evaporator inlet, warming the evaporators and causing the ice cubes to release.

# CME855A & CME1000A

## WATER SYSTEM OPERATION

---

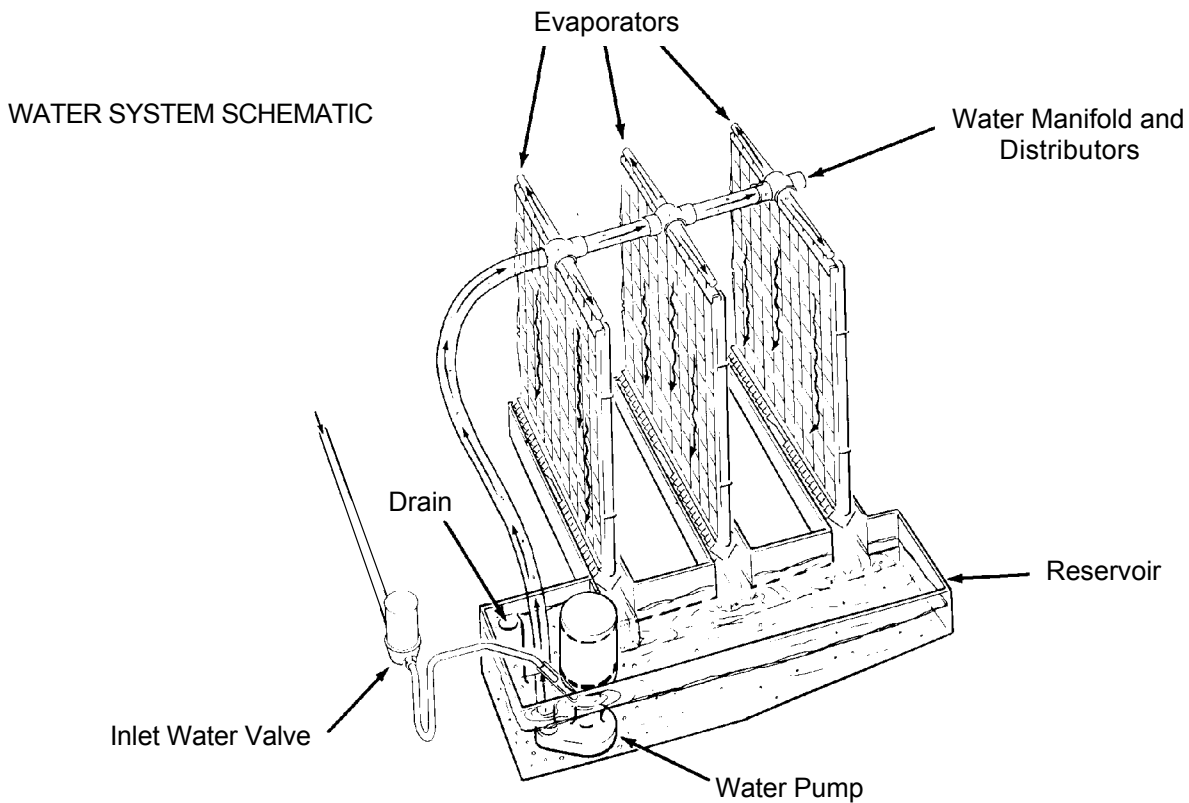

A fixed charge of water is brought into the reservoir during the harvest cycle.

A water pump, running continuously, forces the water to the top of the evaporators, where it is distributed through manifolds, and then cascades down the evaporator surface by gravity.

As it flows across the refrigerated evaporators, some of the water will be chilled enough to change form, turn to ice and stay frozen to the evaporator.

Most of the water returns to the reservoir, to be sucked back into the pump and re-pumped over the evaporators.

Water is forced over the evaporators during the freeze cycle to be changed into ice, and during the harvest cycle to assist the release of the ice.

## COMPONENT DESCRIPTION

---

### Compressor Contactor

The compressor contactor carries the compressor line current. The compressor contactor coil has power whenever the ice machine is making or harvesting ice.

### Cube Size Control

This reverse acting (closes on temperature fall) thermostat determines how long the freezing cycle will be. The cube size control closes it's contacts when the evaporator & suction line cools to the set temperature. When the cube size control closes, it connects power to the timer motor. A variation in heat load (either ambient air or incoming water temperature) will affect the efficiency of the refrigeration system, and that will vary the length of time it takes the evaporators to cool to the temperature at which the cube size control is set to close, which, in turn, will affect the overall cycle time. See CUBE SIZE ADJUSTMENT BEFORE attempting to adjust the control.

### Relay

The multi-function, three pole, double throw, relay plugs into a socket on the printed circuit board in the control box. When the relay coil has power, the machine is in a freeze cycle, and when power is removed from the coil, the machine will be in the harvest cycle.

The relay also by-passes the bin control during the harvest and freeze cycles, preventing the ice maker from shutting off in the middle of a cycle. The bypass action allows only complete freeze and harvest cycles; the only time that the ice maker can shut off on bin control is as the end of the harvest cycle.

### Timer - Timer & Switch Assembly

The timer begins to turn when activated by the cube size control. The outer surface, or large diameter lobe of the timer cam, determines the length of time for finish freezing of the ice cubes, while the inner surface, or small diameter lobe, determines length of the harvest cycle. The single-pole, double throw microswitch on the timer controls the power to the plug in relay coil, making it either the freezing or harvest cycle. The microswitch is actuated by the cams connected to the timer motor. The timer cam can be adjusted to vary the defrost time, as required. One complete rotation of the cam will take eight minutes.

### Hot Gas Solenoid Valve

The hot gas solenoid valve opens only during the harvest cycle. When it opens, it diverts the hot discharge gases so that they flow directly into the evaporator plates, by-passing the condenser and thermostatic expansion valve. The hot gases warm the evaporators, releasing the ice cubes from the ice cube molds. The hot gas solenoid valve is installed in a branch of the discharge line, and when the timer switches the ice machine into the harvest cycle, the energized solenoid coil lifts the valve stem within the valve body, allowing the hot discharge gas to be diverted to the evaporators.

### High Temperature Cut Out

This temperature sensor is located next to the hot gas valve, on the outlet side.

Cut Out is 140°F., Cut In is 110°F.

During normal operation, it does not affect the ice machine, but it will shut the machine off if the hot gas line overheats. It is an automatic reset.

# CME855A & CME1000A

## COMPONENT DESCRIPTION

### Electric Water Inlet Valve

The water inlet solenoid valve fills the reservoir assembly with water. Excess water overflows out the overflow standpipe located at the back of the reservoir. This action fills and rinses the reservoir during each harvest cycle. The flow rate is .75 g.p.m.

### Water Distribution System

The water distribution system evenly supplies water to all cells of the evaporator plates. The water pump pumps water from the reservoir up the vertical tygon tube to the tee. From there water is channeled through the water manifold to the water distributors, above each evaporator plate, and from six holes within each distributor, water flows to the cells of each side of the evaporator plates. Gravity flow returns the unfrozen excess portion of water to the reservoir for recirculation.

### Reservoir

The reservoir, located below the evaporators, stores the inlet water charge, and collects the water that flows over the evaporator plates. Most ice will be falling into the bin below the center evaporator.

### High Pressure Cut Out

This is a manual reset control that shuts down the ice maker, should the discharge pressure ever reach 450 PSIG.

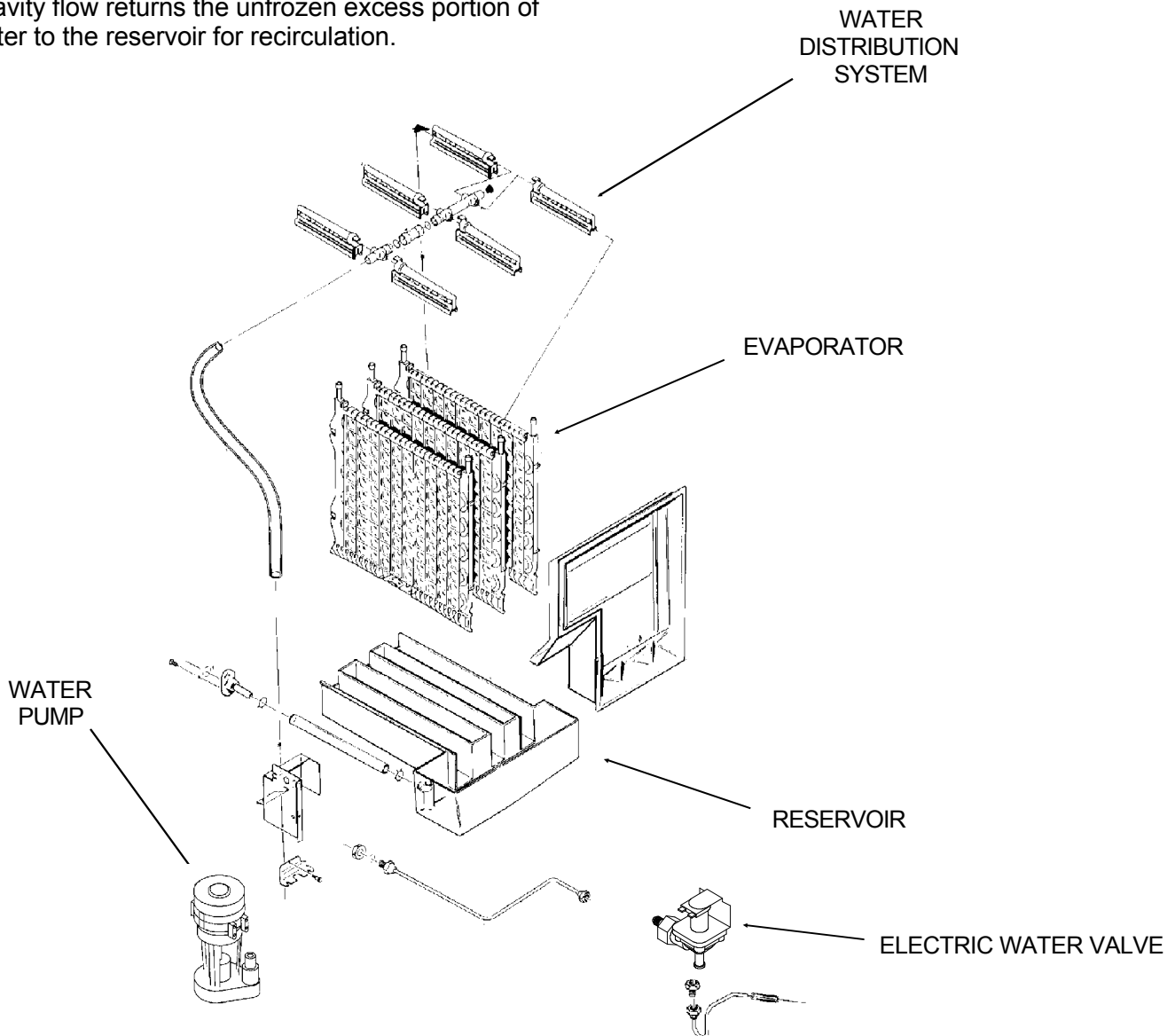



## SERVICE SPECIFICATIONS: CME855A

When servicing a machine, it's helpful to compare that unit's operating characteristics to those of a new, clean, normally operating machine. What follows is that type of information:

Numbers = Cabinet Air Temp/Water Temp.

	70/50	90/70
Typical Cycle Time	14 - 15 minutes	17 - 18 minutes
Harvest Time (2 <sup>2</sup> / <sub>3</sub> minute standard)	2 <sup>2</sup> / <sub>3</sub> minutes	2 minutes
Typical Freeze Cycle Low Side Pressure (end of cycle)	26 PSIG	32-32 PSIG
Typical Freeze Cycle Discharge Pressure (end of cycle)	195 PSIG	255 PSIG
Typical Harvest Cycle Low Side Pressure (peak)	84 PSIG	107 PSIG
Typical Harvest Cycle Discharge Pressure (min)	140 PSIG	180 PSIG

### Typical Batch Weight

- 8.25 - 9 lb.

### Refrigerant Charge

- 36 ounces of R-404A.

### Hi Pressure Cut Out Point

- 450 PSIG

### Hi Temperature Cut Out Point

- 140°F.

### Typical Compressor Amp Draw

- at 90/70: 5 min. into freeze: 9.9, in harvest 10.8
- at 70/50: 5 min. into freeze: 8.9, in harvest 8.3

### Compressor:

- CS14K6E

### Water Inlet Valve Flow Rate:

- .75 g.p.m.

### Cube Size Thermostat:

- Cut in adjustable between 0°F. and 24°F.

### Bin Thermostat:

- CI= 38.5°F. to 43.5°F.
- CO= 33.5°F. to 38.5°F.

### Thermostatic Expansion Valve

- Not adjustable

# CME855A & CME1000A

## SERVICE SPECIFICATIONS: CME1000A

---

When servicing a machine, it's helpful to compare that unit's operating characteristics to those of a new, clean, normally operating machine. What follows is that type of information:

Numbers = Cabinet Air Temp/Water Temp.

	70/50	90/70
Typical Cycle Time	11 - 12 minutes	13 - 14 minutes
Harvest Time (2 <sup>2</sup> / <sub>3</sub> minute standard)	2 <sup>2</sup> / <sub>3</sub> minutes	2 minutes
Typical Freeze Cycle Low Side Pressure (end of cycle)	25 PSIG	25 PSIG
Typical Freeze Cycle Discharge Pressure (end of cycle)	190 PSIG	240 PSIG
Typical Harvest Cycle Low Side Pressure (peak)	84 PSIG	94 PSIG
Typical Harvest Cycle Discharge Pressure (min)	155 PSIG	190 PSIG

### Typical Batch Weight

- 8.25 - 9 lb.

### Refrigerant Charge

- 42 ounces of R-404A.

### Hi Pressure Cut Out Point

- 450 PSIG

### Hi Temperature Cut Out Point

- 140°F.

### Typical Compressor Amp Draw

- 90/70: 5 min. into freeze - 11.5, harvest -13.3
- 70/50: 5 min. into freeze - 10.7, harvest -11.8

### Compressor:

- CS18K6E

### Water Inlet Valve Flow Rate:

- .75 g.p.m.

### Cube Size Thermostat:

- Cut in adjustable between 0°F. and 24°F.

### Bin Thermostat:

- CI= 38.5°F. to 43.5°F.
- CO= 33.5°F. to 38.5°F.

### Thermostatic Expansion Valve

- Not adjustable

## CLEANING

A Scotsman Ice System represents a sizable investment of time and money in any company's business. In order to receive the best return for that investment, it MUST receive periodic maintenance. Maintenance and Cleaning should be scheduled at a minimum of twice per year.

### CLEANING: ICE MAKER

1. Remove front panel.
2. Switch the Wash/Off/Ice switch to OFF.
3. Remove the front liner.
4. Remove and discard all ice from the storage bin.
5. Locate the reservoir drain and drain the reservoir. If the reservoir doesn't drain completely, disconnect the pump hose attached to the water distributors and place the end of the hose in a bucket. Switch the Wash/Off/Ice switch to Wash, and allow the pump to discharge the rest of the water. Reattach the hose to the water distributors.
6. Mix 8 ounces of Scotsman Ice Machine Cleaner with 1 gallon of warm (95<sup>0</sup>F. - 115<sup>0</sup>F.) water and pour into the reservoir until full.

13. Replace the front panel

14. Check the next batch of cubes to make sure all of the acid taste is gone.

### CAUTION

DO NOT use ice produced from the cleaning solution. Be sure none remains in the bin.

15. Remove and discard all ice from the storage bin, pour hot water into the storage bin to melt the cubes and also clean out the bin drain.

16. The unit is now ready for continued automatic operation.

<b>▲WARNING</b>	Scotsman Ice Machine Cleaner contains acids. These compounds may cause burns.
	If swallowed, DO NOT induce vomiting. Give large amounts of water or milk. Call Physician immediately. In case of external contact, flush with water.
	<b>KEEP OUT OF THE REACH OF CHILDREN.</b>

7. Switch the Wash/Off/Ice switch to "wash". Let the unit operate for 30 minutes, then switch the unit off.

8. Drain the reservoir again (repeat step 5)

9. Switch the machine to "wash" and continue to add fresh water to flush residual cleaner from the system. Switch the Wash/Off/Ice switch off.

10. Sanitize the ice maker and bin, see "Sanitize Water System".

11. Replace the front liner.

12. Switch the Wash/Off/Ice switch back on.

# CME855A & CME1000A

## CLEANING

---

### SANITIZE WATER SYSTEM

1. Remove and discard all ice from the bin.
2. Remove front panel.
3. Drain the reservoir
4. Prepare 2 gallons of an approved sanitizer solution in accordance with the instructions on the package, or use the following instructions for use of household bleach, if it meets local codes:  
Mix a sanitizing solution of 1 ounce of household bleach to 2 gallons of water.
5. Pour 1 gallon of the sanitizer into the ice maker reservoir.
6. Move the Wash/Off/Switch switch to "Wash", and allow the solution to circulate for a MINIMUM of 5 minutes.
7. Move the Wash/Off/Switch switch to "Off".
8. Remove the drain plug and drain the reservoir.
9. Using a clean sponge and the remainder of the sanitizer solution, wipe the interior of the evaporator cover and the inside of the storage bin, taking care to wipe all surfaces that are normally in contact with ice.
10. Replace the evaporator cover. Replace the front panel.
11. Move the master switch to ON.

### SANITIZE ICE STORAGE BIN

This procedure is to be done monthly

1. Remove and discard all ice from the bin.
2. Switch the ice maker off.
2. Prepare 2 gallons of an approved sanitizer solution in accordance with the instructions on the package, or use the following instructions for use of household bleach, if it meets local codes: Mix a sanitizing solution of 1 ounce of household bleach to 2 gallons of water.
3. Using clean rubber gloves and a clean cloth, wipe all interior surfaces of the ice machine and ice storage bin with the sanitizing solution. Immerse any small parts in the sanitizing solution and wash the parts, flushing the solution thoroughly in, over and through all parts and surfaces of the parts being cleaned.
4. Allow to air dry.
5. Switch the ice machine back on.

## SERVICE DIAGNOSIS

SYMPTOM	POSSIBLE CAUSE	PROBABLE CORRECTION
No ice, machine does not run	1. No electrical power	1. Restore power
	2. Circuit breaker tripped or fuse blown	2. Reset breaker or replace fuse, check for electrical fault.
	3. High pressure control open.	3. Reset HPC, check fan motor for proper operation, and condenser coil for dirt.
	4. Bin Thermostat holding machine off	4. Check bin thermostat.
	5. High temp. cut out open	5. Hot gas valve leaks thru, replace hot gas valve
	6. Timer switch open	6. Replace timer
	7. Master switch open	7. Check or replace switch.
	8. Circuit board open	8. Replace circuit board.
No ice, compressor does not run, rest of ice machine does.	1. Open contactor coil	1. Replace contactor
	2. Thermostatic Expansion valve clogged or does not open.	2. Check/replace TXV.
No ice, no water over evaporators	1. Water pump does not pump	1. Check/replace water pump
	2. No water in reservoir	2. Check/replace water inlet valve.
No ice, everything runs	1. Too much heat load	1. Check for slow leak thru of water inlet valve.
	2. Low on refrigerant	2. Check pressures, if low find/repair leak; weigh in charge.
	3. Suction pressure too high	3. Defective compressor - replace
Low ice production	1. Too much heat load.	1. Check condenser air inlet temperature. Check water temperature.
	2. Compressor inefficient.	2. Replace compressor
	3. Non condensable gasses in refrigeration system.	3. Check head pressure, if very high, and no other reason is suspected, replace refrigerant charge.

# CME855A & CME1000A

## SERVICE DIAGNOSIS

SYMPTOM	POSSIBLE CAUSE	PROBABLE CORRECTION
Low ice production	4. High head pressure, a result of a dirty condenser	4. Clean water circuit of condenser
	5. Hot gas valve leaks thru	5. Replace hot gas valve
	6. High discharge pressure	6. If possible, reduce condenser water inlet temperature.
No ice falling in bin, unit frozen up	1. Cube size control will not close	1. Check temp. of suction line, cube size control will not close if temp. too high. If temp. low enough, replace cube size control
	2. Timer motor open	2. Replace timer
	3. Plug in relay contacts open	3. Replace relay
	4. Not enough time during the harvest cycle to drop all ice	4. Adjust timer for more harvest time
	5. Cube size wrong	5. Adjust cube size
	6. Hot gas valve restricted.	6. Replace hot gas valve.
	7. Not enough water to help harvest.	7. Check for restriction of water supply.
	8. Head pressure too low	8. Check water reg./pressure control valve. Check for low refrigerant charge.
Ice maker stuck in harvest cycle	1. Relay coil open	1. Replace relay
	2. Timer stuck in harvest cycle	2. Check for power to timer motor, if power replace timer, if no power to timer motor, replace relay.
	3. Timer microswitch N.O. contacts will not close.	3. Replace timer.
Ice is mal-formed	1. Shortage of water	1. Check for restriction of water supply. Check for leak.
	2. Evaporator water passages restricted.	2. Clean ice maker.
	3. Cube size set wrong	3. Adjust cube size control
Water overflows from reservoir into bin.	1. Restricted sump drain	1. Repair drain
	2. Inlet water valve lets in too much water	2. Replace valve

## REMOVAL AND REPLACEMENT

### **▲WARNING**

Disconnect electrical power before beginning.

#### Cube Size Control

To remove the cube size control:

1. Remove front panel.
2. Remove cover from control box.
3. Trace capillary tube, from the cube size control to the refrigerant suction line.
4. Remove the coiled capillary tube bulb from the tube well on the suction line.
5. Remove electrical leads from the cube size control.
6. Remove screws and the cube size control. To replace the cube size control, reverse the removal procedure. Be certain to re-insulate the cube size control bulb.

#### Water Distributor Tubes And Manifold Tubes

To remove the water distributor tube and manifold tube:

1. Pull out to unsnap catches and remove the front panel.
2. Remove the evaporator cover.
3. Slide the water distributor tube to the front about 1/8-inch along the top of the evaporator plate, until the water distributor tube can be unsnapped from the flexible notch and lifted upward to the right side.
4. Unsnap and disconnect water distributor tubes from the water manifold section. To replace the water distributor tubes and manifold tubes, reverse the removal procedure.

BE SURE the notches in the water manifold tubes properly engage the alignment keys in the tee. BE SURE the water distributor tube is securely fastened at the notch at both sides of the evaporator plate.

Check identical attachment for the left water distributor tube and notch; also, that the distributor/manifold connections at the top center of each evaporator plate is snug against the top of the plate.

#### Inlet Water Solenoid Valve Assembly

To remove the inlet water solenoid valve assembly:

1. Shut OFF water supply to machine.

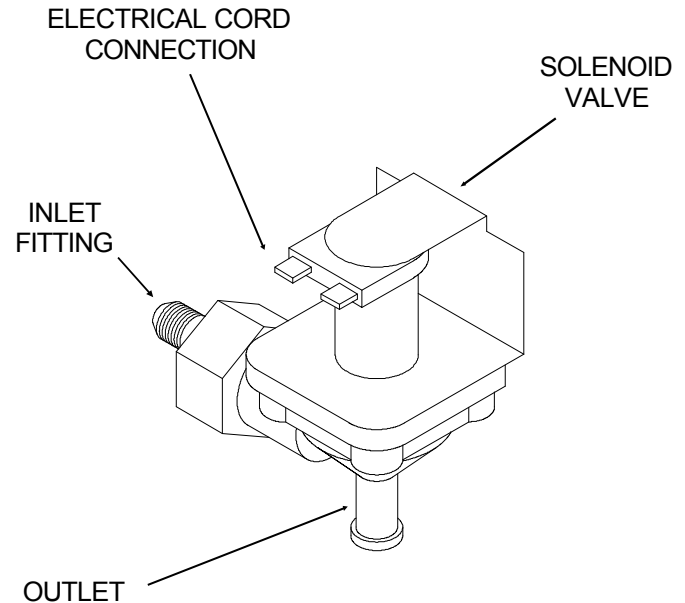

#### REMOVAL OF THE INLET WATER VALVE

2. Loosen and remove outlet water line from the inlet water solenoid valve assembly.
3. Remove screws and pull the water solenoid valve out to gain access.
4. Pull electrical cord connection from solenoid coil terminals.
4. Remove inlet water fitting from the water solenoid valve. To replace the inlet water valve assembly, reverse the removal procedures.

# CME855A & CME1000A REMOVAL AND REPLACEMENT

## **▲WARNING**

Disconnect electrical power before beginning.

### Water Pump

1. Remove front panel.
2. Remove evaporator cover.
3. Unplug water pump electrical connection.
4. Remove thumb screw retaining pump to cross brace.
5. Pull pump partially out of reservoir and remove discharge hose.

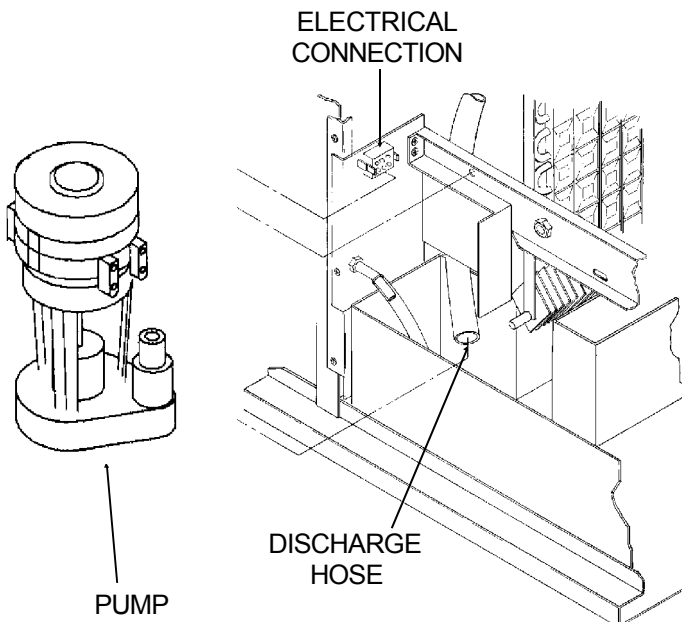

REMOVAL OF THE WATER PUMP

6. Reverse to reassemble.
7. Replace all panels.
8. Reconnect electrical power.

### Hot Gas Valve

1. Remove the side service panel, and top panel if possible.
2. Discharge and recover the refrigerant from the system.
3. Remove the electrical connections from the coil of the valve
4. Cut out or unsweat the valve at the tubing connections, remove the valve from the ice maker.
5. Install the new valve, wrap it in wet cloths or other efficient heat sink material.
6. Sweat the tubing connections to the valve.
7. Connect the electrical wires to the terminals of the valve coil.
8. Weigh in the nameplate charge.
9. Replace all panels removed for service.
10. Reconnect electrical power.

### Thermostatic Expansion Valve

1. Remove the side service panel, and top panel if possible.
2. Discharge and recover the refrigerant from the system.
3. Locate the TXV sensing bulb on the suction line, unwrap the insulation and remove the bulb from the clamp.
4. Cut out or unsweat the old TXV from the tubing connections.
5. Wrap the new TXV body in wet cloths or other efficient heat sink material.
6. Sweat in the new valve. Do not overheat.
7. Re-attach the TXV bulb to the suction line in the same place as the original. Be certain to re-insulate.
8. Install a new HFC type drier.
9. Evacuate to at least 200 microns.
10. Weigh in the nameplate charge.
11. Replace all panels removed for service.
12. Reconnect electrical power, and restart machine.



## REFRIGERATION SERVICE

This ice machine uses R-404A refrigerant and polyolester oil. Do NOT use mineral oil in this refrigeration system.

- R-404A is a "Near Azeotrope" so liquid charging is required: See the next page.
- When the system is serviced, a special liquid line drier is required. It is included with replacement compressors.
- HP62 is not compatible with mineral oil, so these ice machines use Polyolester oil. Polyolester oil absorbs water very easily. When one of these refrigeration systems is opened for service, it must be re-sealed as soon as possible (15 minutes maximum).
- Special leak detection equipment is required to locate small refrigerant leaks. Usually a leak detector capable of detecting a Halogenated refrigerant or HFC-134a will work. Check with the leak detector manufacturer if in doubt.

Access Valves: To use the access valves:

- Remove the cap from the stem, use a 3/16" allen wrench to check that the valve is CLOSED. Then remove the core cap.
- Close the valve and replace the caps when the job is finished. The valve must be closed and the caps must be on or the valve will leak.

General Information:

Work on the refrigeration system should only be done when it is certain that the system needs repair.

- Refrain from checking refrigeration pressures without reason. Visual inspection of the water system, observation of the ice formation, amp draw, voltage, and other techniques will lead to proper diagnosis.
- If gauges must be used, don't always check the high side pressure. If the condenser is clean and seems to be operating correctly, it most likely is.
- If gauges must be used, use very short hoses to minimize refrigerant discharged into the air.
- Refrigerant should not be added except as a way to determine the proper operation of the product. If the system was low on refrigerant, there is a leak, and it must be found and repaired.
- This system has a critical charge, it must be recharged with the correct amount of refrigerant as listed on the nameplate of the ice machine, or performance will suffer.
- Anytime the refrigeration system has been opened, the dryer should be replaced. Note: Only a HFC type dryer can be used.
- When brazing the tubing connections to components such as the TXV, the component must be protected by heat sink material.

Recover, reclaim or recycle refrigerant . The method chosen is up to the service company. Any refrigerant placed into a Scotsman ice machine must meet ARI spec 700-88. Reclaim programs are available through most refrigerant wholesalers.

Pressure-Temperature Chart for HP62

TEMP. (DEG F)	VAPOR		VAPOR	
	PRES. (PSIG)	TEMP. (DEG F)	PRES. (PSIG)	TEMP. (DEG F)
-20	17	70	146	
-18	18	72	150	
-16	20	74	155	
-14	21	76	161	
-12	23	78	166	
-10	24	80	171	
-8	26	82	177	
-6	28	84	182	
-4	29	86	188	
-2	31	88	194	
0	33	90	200	
2	35	92	206	
4	37	94	212	
6	39	96	219	
8	41	98	225	
10	43	100	232	
12	46	102	239	
14	48	104	246	
16	50	106	253	
18	53	108	260	
20	55	110	268	
22	58	112	275	
24	60	114	283	
26	63	116	291	
28	66	118	299	
30	69	120	307	
32	72	122	316	
34	75	124	324	
36	78	126	333	
38	81	128	342	
40	85	130	351	
42	88	132	360	
44	91	134	370	
46	95	136	379	
48	99	138	389	
50	102	140	399	
52	106	142	409	
54	110	144	420	
56	114	146	430	
58	118	148	441	
60	123	150	452	
62	127	152	464	
64	132	154	475	
66	136	156	487	
68	141	158	499	

# CME855A & CME1000A

## LIQUID CHARGING

### Instructions for R-404A

In preparation for charging, the low side hose should have a sight glass, and/or a restrictor device (such as a "Charge Faster") installed in it for metering liquid into the low side of the system.

1. After a thorough evacuation to at least 200 microns, shut off the manifold valves and switch off the vacuum pump.
2. Place a drum of R-404A onto an electronic scale.
3. Attach the charging hose to the drum.
4. Open the valve on the drum and purge the charging hose.
5. Zero out the scale.
6. Shut the low side access valve at the ice machine.
7. Open the discharge manifold valve full open.
8. Watch the scale, when the correct charge is shown, shut the manifold valve.

Note: If all of the charge will not "go in" the discharge side:

- A. Shut the discharge access valve at the ice machine.
- B. Switch the machine on.
- C. Open the low side access valve at the ice machine.
- D. Open the low side manifold valve and observe the sight glass to be certain that only gas is flowing into the system.

E. When the proper charge is indicated on the scale, shut off the manifold valve(s).

9. Shut off the valve on the refrigerant drum.
10. Re-open the manifold valves until all liquid has flowed out of the hoses.
11. Shut the low side access valve on the ice machine.
12. Remove hoses from ice machine and replace all caps.

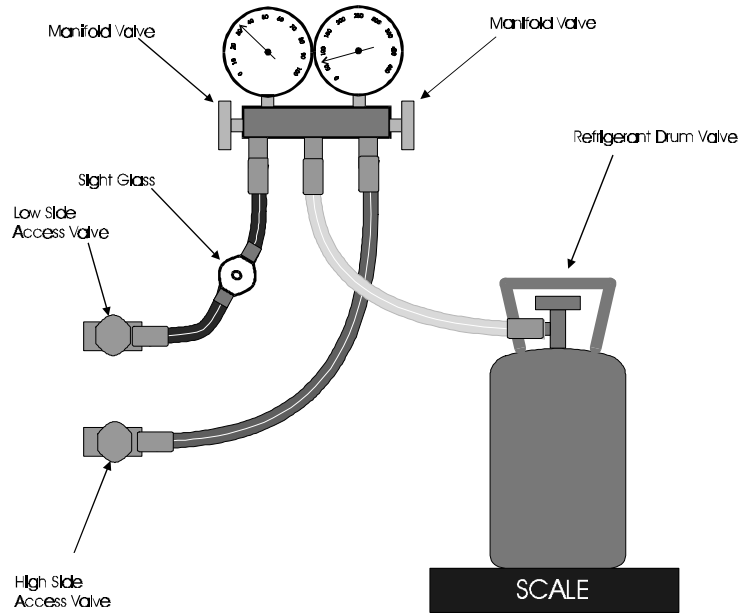

Hose Connection Schematic for Liquid Charging

