

**INTRODUCTION**

---

This manual is intended as a reference for the installation of a Scotsman ice maker model CMS1002.

**TABLE OF CONTENTS**

	Page
Specifications . . . . .	2
Environmental Limitations . . . . .	3
For the Installer	
Machine & Bin Assembly . . . . .	4
For the Plumber . . . . .	5
For the Electrician . . . . .	6
Final Check List . . . . .	7
Initial Start Up . . . . .	8
Adjustments . . . . .	10
Component Description . . . . .	11
Service Specifications . . . . .	14
Cleaning . . . . .	15
Service Diagnosis . . . . .	17
Removal and Replacement . . . . .	21

# CMS1002W

## SPECIFICATIONS

Always refer to the nameplate, located on the back of the cabinet, for the:

- model number,
- serial number,
- basic electrical requirements,
- minimum circuit ampacity,
- maximum fuse size,
- and refrigerant charge.

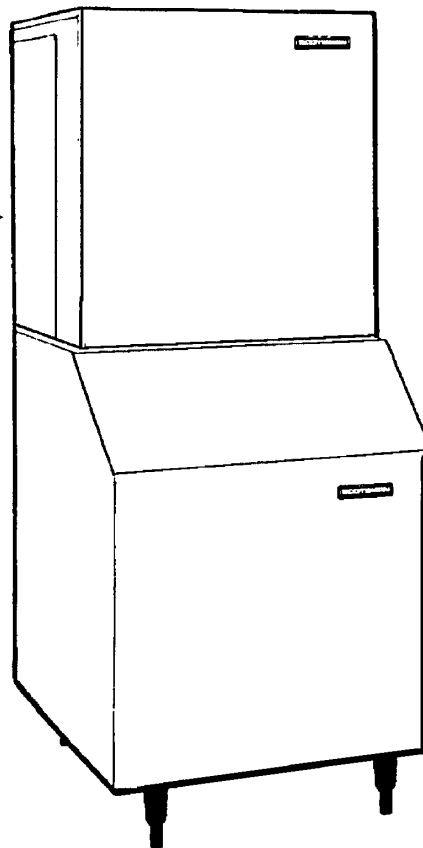
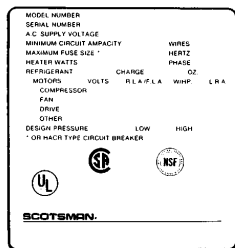

A serial number plate with the model number, serial number and refrigerant charge is located behind the front panel, near the control box.

The unit comes from the factory with the correct refrigerant charge. The refrigerant charge information is for recharging, should that be necessary.

All utility connections are made at the back of the ice maker.

Before beginning installation, be sure that all of the components necessary for complete assembly of the ice system are available, and are the correct components with regard to model, voltage, and finish.

A stacking kit (KSCMS) is required for stacking CMS1002 ice machines. It interconnects the sonar bin ice level controls. CMS1002 may only be stacked onto another CMS1002.

The CMS1002 will fit any 30" wide Scotsman bin without needing a bin top. Other bins will require a bin top.

Model Number	Dimensions W" x D" x H"	Basic Electrical	Refrigerant Type	Refrigerant Charge*
CMS1002WE-32A	30 x 24 x 27	208-230/60/1	R-22	55 ounces
CMS1002WE-3A	30 x 24 x 27	208-230/60/3	R-22	55 ounces

\* The system charge is in the machine. This number is for recharging purposes only. If the nameplate has a different value, go by the nameplate.

	Air Temperature	Water Temperature	Voltage
Minimum	50 <sup>0</sup> F.	40 <sup>0</sup> F.	-5%
Maximum	100 <sup>0</sup> F.	100 <sup>0</sup> F.	+10%

## FOR THE INSTALLER: Environmental Limitations

### Installation Limitations

The ice making portion of this ice system is designed to be installed indoors, in a controlled environment.

	Minimum	Maximum
Air Temp	50 <sup>0</sup> F.	100 <sup>0</sup> F.
Water Temp	40 <sup>0</sup> F.	100 <sup>0</sup> F.
Water Pressure	20 PSI	80 PSI
Voltage	197	253

Operating the ice machine outside of the above limitations, or outdoors, is potentially damaging to the machine; also it is misuse of the machine, which may void the warranty.

Scotsman Ice Systems are designed and manufactured with the highest regard for safety and performance. They meet or exceed the standards of UL, NSF, and CSA.

Scotsman assumes no liability or responsibility of any kind for products manufactured by Scotsman that have been altered in any way, including the use of any part and/or other components not specifically approved by Scotsman.

Scotsman reserves the right to make design changes and/or improvements at any time.

Specifications and design are subject to change without notice.

### Water Limitations



An ice machine is a food manufacturing plant; it takes a raw material, water, and turns it into a food product, ice. The purity of the water is very important in obtaining pure ice and in maximizing product life. These general recommendations should help keep the ice maker clean:

1. Filter the water used to produce ice. Water filters vary greatly in ability and function. Install one that filters out suspended solids to a dimension of 5 microns or smaller. The finer the filter the better, but finer filters will clog sooner than course ones. It may be necessary to add a course filter ahead of the fine filter to prolong filter life.
2. Check with a water treatment specialist for a water test, and recommendations regarding filters and treatment.

### Service Limitations

Some space on the sides, the back and the top should be allowed for service and utility connections.

**NAMEPLATE, LOCATED ON  
BACK PANEL.  
A SERIAL NUMBER PLATE IS  
LOCATED BEHIND THE  
FRONT PANEL, NEAR THE  
CONTROL BOX.**

MODEL NUMBER					
SERIAL NUMBER					
A.C. SUPPLY VOLTAGE					
MINIMUM CIRCUIT AMPACITY			WIRES		
MAXIMUM FUSE SIZE *			HERTZ		
HEATER WATTS			PHASE		
REFRIGERANT		CHARGE	OZ.		
MOTORS	VOLTS	R.L.A./F.L.A.	W/H.P.	L.R.A.	
COMPRESSOR					
FAN					
DRIVE					
OTHER					
DESIGN PRESSURE		LOW	HIGH		
* OR HACR TYPE CIRCUIT BREAKER					
  					
<b>SCOTSMAN.</b>					

# CMS1002W

## FOR THE INSTALLER: Machine & Bin Assembly

---

### Overview:

This ice system is comprised of 2 major assemblies:

1. The ice storage bin.
2. The ice maker itself.

### Storage Bin:

After uncrating the ice storage bin, attach the legs to the bin:

1. Use a portion of the carton as a cushion, and tip the storage bin on its back.
2. Screw the legs into the threaded holes in the bottom of the bin.
3. Turn the leg levelers all the way in to prepare the bin and ice machine for leveling.
4. Return the bin to the upright position.

### Ice Maker:

1. Arrange for proper electric, water and drain.

See instructions for the plumber and for the electrician.

2. Position the ice storage bin in the selected location.
3. Level the bin, in both the front to rear and side to side directions.
4. Inspect the bin top mounting gasket which should be flat, with no wrinkles, to provide a good water seal when the cuber is installed on top of the bin.
5. Install the modular cuber on top of the bin using care to be sure a good seal is made between the two cabinets, use of a mechanical lift is recommended. Align the holes in the bottom back of the cabinet to mate with the two mounting straps on the top rear of the bin.
6. Use bolts and straps found in the hardware package to secure the ice machine to the ice storage bin. When alignment and leveling are completed, tighten the bolts to secure the mounting straps.

## FOR THE PLUMBER

### Water Supply

The recommended water supply line is a 3/8-inch O.D. tubing with a minimum operating pressure of 20 PSIG and a maximum of 80 PSIG.

A separate water inlet is required for the condenser water supply.

Connect to cold water supply line with standard plumbing fittings, with shut off valve installed in an accessible place between the water supply and the cuber. In some cases a plumber will be required.

CONFORM TO ALL LOCAL CODES

### Drain Connections:

Connections: All drains are gravity type and must have a minimum of 1/4 - inch fall per foot of horizontal run. The drains to be installed must conform with the local plumbing codes. Install a vertical open vent on the ice machine reservoir drain. The ideal drain receptacle is a trapped and vented floor drain. The storage bin drain should be insulated.

Water Cooled Connection: A separate cold water supply is required, connect to the 3/8-inch FPT fitting at the back of the cabinet. An additional drain line is required to drain the water cooled condenser, and must not interconnect to any of the other drains.

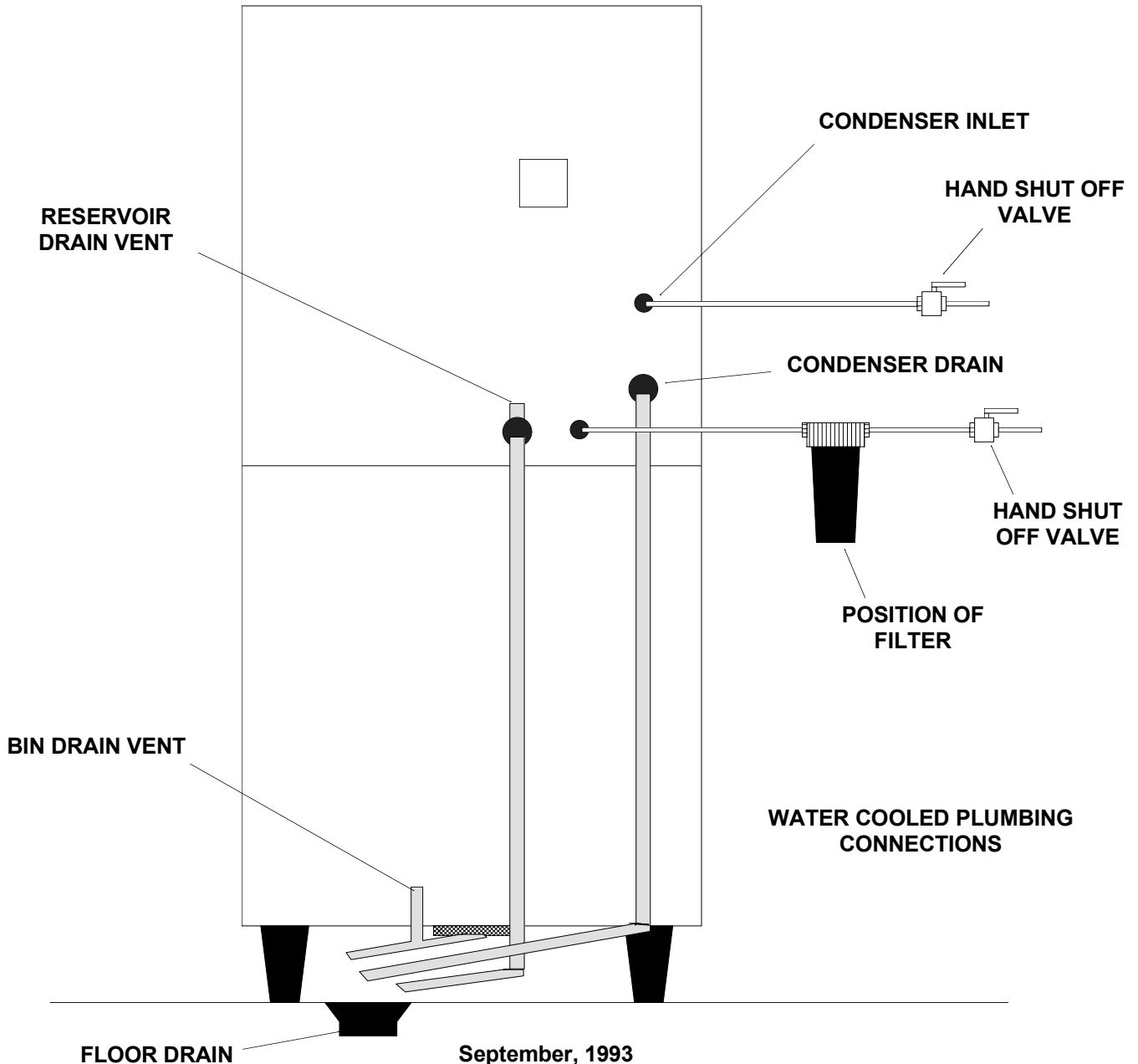

# CMS1002W

## FOR THE ELECTRICIAN: Electrical Connections

See the NAMEPLATE for current requirements to determine wire size to be used for electrical hookup. The cuber requires a solid chassis to chassis earth ground wire. See Wiring Diagram.

Be certain the cuber is connected to its own electrical circuit and individually fused. Voltage variation should not exceed ten percent of the nameplate rating, even under starting conditions. Low voltages can cause erratic operation and may be responsible for serious damage to the icemaker.

Electrical connections are made at the rear of the icemaker, inside the junction box.

The cuber is packaged with a flexible cord and matching receptacle (not attached), use them to make electrical connection between the icemaker and the building's electrical power, if allowed by local codes.

**All external wiring should conform to the national, state and local electrical code requirements. Usually an electrical permit and services of a licensed electrician will be required.**

**ELECTRICAL JUNCTION BOX**

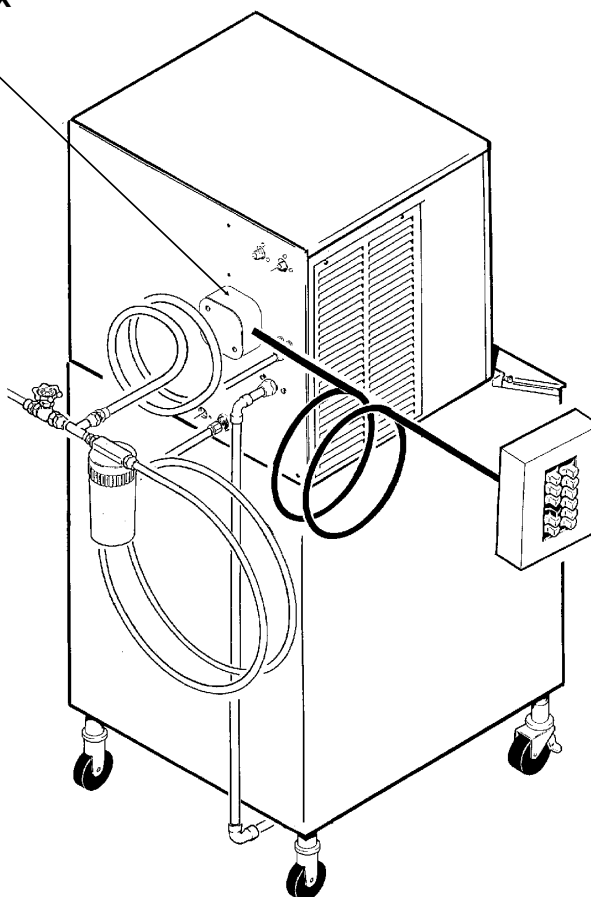

**FUSES or HACR  
CIRCUIT BREAKERS**

**FOR THE INSTALLER: Final Check List**

---

1. Is the ice maker cabinet in a room where ambient temperatures are within the minimum and maximum temperatures specified?
2. Is there clearance at both sides of the cabinet and at the back and top for service and utility connections?
3. Has water supply pressure been checked to insure a minimum of 20 PSIG and a maximum of 80 PSIG operating pressure?
4. Is the cabinet level?
5. Check that any shipping material has been removed from inside the cabinet.
6. Have all electrical and piping connections been made?
7. Are the Master and Compressor switches on OFF?
8. Has power been connected to the ice maker?
9. Is the water supply line shut off valve installed?
10. Check all refrigerant lines and conduit lines, to guard against vibration or rubbing and possible failure.
11. Have the bin and cabinet been wiped clean and sanitized?
12. Has the Field Quality Audit form been properly filled out? Check for correct model and serial numbers from Serial nameplate, then mail the completed form to the SCOTSMAN factory.
13. Has the owner been given the name and telephone number of the authorized SCOTSMAN Service Agency serving him?

# CMS1002W

## INITIAL START UP

### Ice Maker:

1. Remove front panel by pulling out to unsnap.
2. Remove two screws and the control box cover.
3. Remove the evaporator cover.
4. Remove the left side service panel.
5. Check that the ON/WASH/OFF rocker switch and the Compressor ON-OFF toggle switch are in the OFF position, on the control box.
6. OPEN the water supply line shut off valve.
7. Inside the control box is the shaft of the timer and the switch assembly. Rotate the shaft of the timer and switch assembly clockwise to where the actuator arm on the microswitch drops off outer cam into cam slot. See Timer Cam Positions.

### TIMER CAM POSITIONS

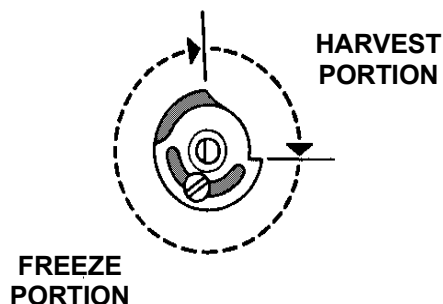
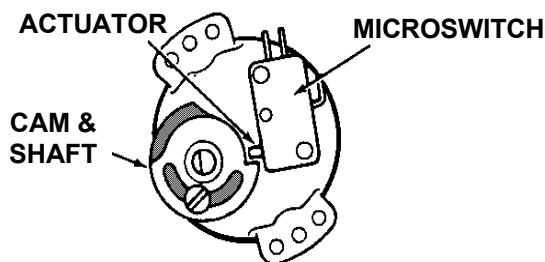

8. Move the ON/WASH/OFF rocker switch to the ON position.

9. Observe water fill cycle: Water pump operates and water inlet solenoid valve OPENS, incoming water flows from the valve through the tubing, the reservoir fills and excess water drains out the machine drain. At the end of the harvest cycle, the water inlet solenoid valve will close and the water fill cycle is complete. If the reservoir is not full, advance the shaft of the timer clockwise into a new harvest cycle; this opens the water valve again. The water pump forces water from the reservoir up to the water distributor at the top of each evaporator plate, where water is uniformly dispensed, cascades down both sides of the evaporator plate and drains back into the reservoir for recirculation.

10. Check that the water cascades down over each cube mold and into the reservoir.

11. When the reservoir is full, move the compressor ON-OFF switch, to the ON position.

12. Check operation of the freezing cycle: The compressor is operating. The icemaking process begins; feeling the metal parts of the evaporator plate reveals cold temperature, very shortly ice begins to form. Tubing will become frosted at the top of the evaporator plate. Freezing time will range between 13 and 15 minutes. Longer time for temperatures above 70 degrees F. and shorter time required when temperatures are below 70-degrees F. Average complete cycle time is about 16 minutes.

13. Warm water should begin to flow from the condenser drain.

Note: To optimize the balance between ice production and water use, the water cooled discharge pressure must be 220 P.S.I.G. Check the discharge pressure and adjust the water regulating valve to obtain 220 P.S.I.G. pressure.

14. Check **CUBE SIZE**

The dimensions of the cubes are fixed by the size and shape of the molds on the evaporator plate, except that the thickness of the cube MAY need to be adjusted at start up. There is only one size of cube that is correct; adjusting the cube size control to that size of cube will allow the ice maker to produce ice at its most efficient size. The correct size cubes will be fully formed at the edges; will harvest off of the evaporators beginning with individual cubes at the top of the evaporator, then vertical strips for the balance; and will appear similar to the illustration for "Correct Size Cube".



## INITIAL START UP

### Adjust for the correct size if needed:

To produce SMALLER sized ice cubes:

Locate cube size control knob, in the front of the control box. Rotate this knob one eighth of a turn counter clockwise. Observe size of the ice cubes in the next ice cube harvest and adjust again if needed, until the correct ice cube is achieved.

To produce LARGER ice cubes:

Locate cube size control on the front of the control box. Rotate the knob one eighth of a turn clockwise. Observe size of ice cubes in the next cube harvest and adjust again if needed, until correct the ice cube size is achieved.

14. Check Harvest Time. The machine must harvest all cubes before returning to a freeze cycle.

Increase the harvest time if there is less than 15 seconds of harvest time after the last cube has fallen into the bin.

Decrease the harvest time if there is much more than 15 seconds of harvest time after the last cube has fallen into the bin. Note: Harvest time is dependent upon the water and air temperatures at the ice machine. Do not adjust harvest time too short, as this will cause a freeze up .

See the next page for detailed harvest time adjustment instructions.

### 15. Check ICE BIN LEVEL CONTROL

The amount of ice maintained in the bin is adjustable. The normal setting is "full". If the operator desires, the level of ice in the bin may be adjusted lower to shut off the machine when the bin is only partially full.

### To Test The Ice Level Setting:

1. Open the bin door and locate on the bottom of the ice machine, the ice level sensor. It's in a socket about 2" in diameter and located left of the evaporator plates.
2. When the machine is running, wait until near the end of a "harvest" cycle.
3. Hold a flat object about the size of this service manual over the ice level sensor socket.
4. The ice machine should turn off at the end of the harvest cycle.
5. Slowly lower the flat object straight down.
6. The ice machine will start again at the point where it will maintain the ice level.

### CUBES (ACTUAL SIZE)

TOO THICK

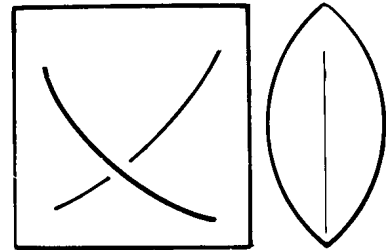

CORRECT SIZE CUBE

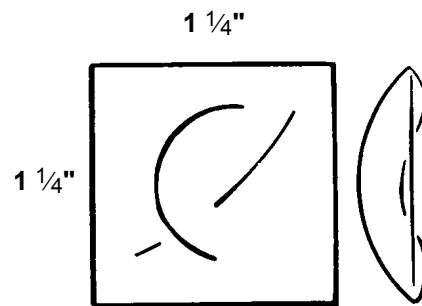

Note: Optimum performance will be achieved when the ice machine is adjusted to produce this size and shape of cube. The typical batch weight at this setting is between 8.25 and 9 pounds.

TOO THIN

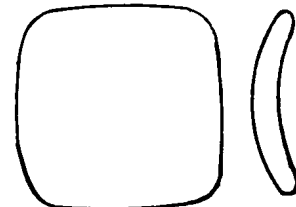

### Adjust Bin Ice Level

1. Locate ice level control knob.
2. Turn knob to the desired position.
3. Replace front panel.
4. To test, wait until the ice machine is near the end of a "harvest" cycle, if there is ice in the bin higher than the position the ice level control is set for, the ice machine will turn OFF at the end of the harvest cycle. If no ice in the bin, test again as described under, "To Test The Ice Level Setting".
16. Replace all panels, the machine is ready for automatic operation.

# CMS1002W

## ADJUSTMENT OF THE TIMER & SWITCH ASSEMBLY

One complete revolution of the cam on the timer represents eight minutes. If left as factory set, four and one-half minutes comprise the freezing cycle portion during cam rotation, and the final three and one-half minutes is the defrost/harvest cycle. Rotating the shaft of the timer cam Clockwise will put the ice machine into the freeze or harvest cycle, as required in the cleaning instructions.

//////////////////WARNING//////////////////  
Disconnect electrical power supply to icemaker whenever adjustment procedures are performed.

To adjust the timer & switch assembly:

1. Remove front panel.
2. Remove control box cover.
  - A. To start the HARVEST CYCLE: Slowly rotate the shaft of the timer and switch assembly, clockwise until the actuator arm on the microswitch initiates the harvest cycle. An audible click can be heard, but in a noisy area, look at the cam and switch to observe the event
  - B. To start the FREEZING CYCLE: Slowly rotate the shaft of the timer and switch assembly clockwise until the actuator arm on the microswitch initiates the freezing cycle.

- C. To adjust the length of the harvest cycle:
  1. Loosen the adjustment screw on the cam and rotate the shaft of the cam to move the cam. More of a gap between the high and low portions will yield more harvest time.
  2. Tighten the set screw.
  3. Replace the control box cover and front panel.

It is important that the length of the harvest cycle allow enough time for all the ice cubes to fall from the evaporator. Too short of a time will cause the evaporator to freeze up and stop ejecting ice into the bin. Too much time wastes icemaking capacity, energy and water. Adjustment of the harvest cycle may require an adjustment of the cube size control.

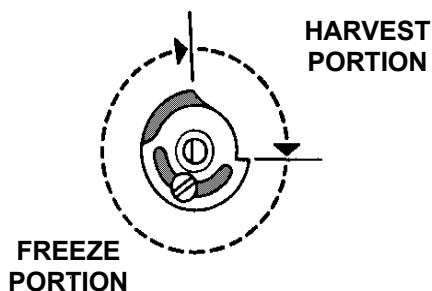
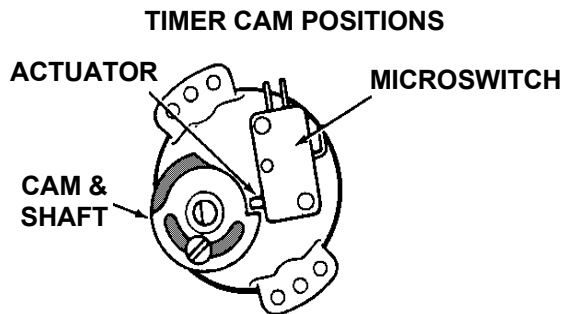

### TIMER ADJUSTMENT

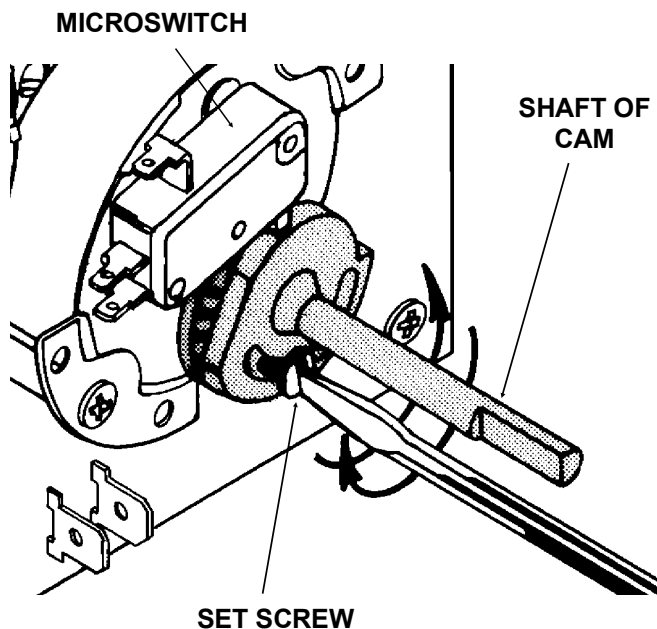

## COMPONENT DESCRIPTION

---

### Compressor Contactor

The compressor contactor carries the compressor line current. The contactor is wired so any control in the pilot circuit, such as the bin control, and high pressure controls, etc., will cause the contactor holding coil to be de energized, when the control contact OPENS, thereby breaking the circuit to the compressor.

### Cube Size Control

This reverse acting (closes on temperature fall) thermostat determines how long the freezing cycle will be. The cube size control closes it's contacts when the evaporator cools to the set temperature, starting the timer. A variation in heat load (either ambient air or incoming water temperature) will affect the efficiency of the refrigeration system, and that will vary the length of time it takes the evaporators to cool to the temperature at which the cube size control is set to close, which, in turn, will affect the overall cycle time. See CUBE SIZE ADJUSTMENT BEFORE attempting to adjust the control.

### Relay

The multi-function, three pole, double throw, relay plugs into a socket on the printed circuit board in the control box. The relay functions in part to by-pass the bin control during the harvest and freeze cycles, preventing the icemaker from shutting off in the middle of a cycle. The bypass action allows only complete freeze and harvest cycles; the only time that the ice maker can shut off on bin control is as the end of the harvest cycle.

### Timer - Timer & Switch Assembly

The timer begins to turn when activated by the cube size control. The outer surface, or large diameter lobe of the timer cam, determines the length of time for finish freezing of the ice cubes, while the inner surface, or small diameter lobe, determines length of the harvest cycle. The single-pole, double throw microswitch on the timer controls the power to the plug in relay coil, making it either the freezing or harvest cycle. The microswitch is actuated by a cam assembly directly connected to the timer motor. The timer cam can be adjusted to vary the defrost time, as required. One complete rotation of the cam will take eight minutes. Harvest is preset at 2 and one quarter minutes.

### Hot Gas Solenoid Valve

The hot gas solenoid valve opens only during the harvest cycle. When it opens, it diverts the hot discharge gases so that they flow directly into the evaporator plates, by-passing the condenser and thermostatic expansion valve. The hot gases warm the evaporators, releasing the ice cubes from the ice cube molds. The hot gas solenoid valve is installed in a branch of the discharge line, and when the timer switches the ice machine into the harvest cycle, the energized solenoid coil lifts the valve stem within the valve body, allowing the hot discharge gas to be diverted to the evaporators.

### High Temperature Cut Out

This temperature sensor is located next to the hot gas valve, on the outlet side.

During normal operation, it does not affect the ice machine, but it will shut the machine off if the hot gas line overheats. It is an automatic reset.

# CMS1002W

## COMPONENT DESCRIPTION

### Ice Level Control

This electronic control uses sound waves to measure the distance between the bottom of the ice machine and the top of the ice in the bin. It is designed to control the machine's ice production to maintain that distance.

The control is adjustable so that the ice machine will maintain a certain height of ice. It will not fill any closer to the ice machine than 8", and will not work if the distance to the bottom of the bin is greater than 8 feet.

Because it uses sound waves, a slight "ticking" sound can be heard coming from the bottom of the machine.

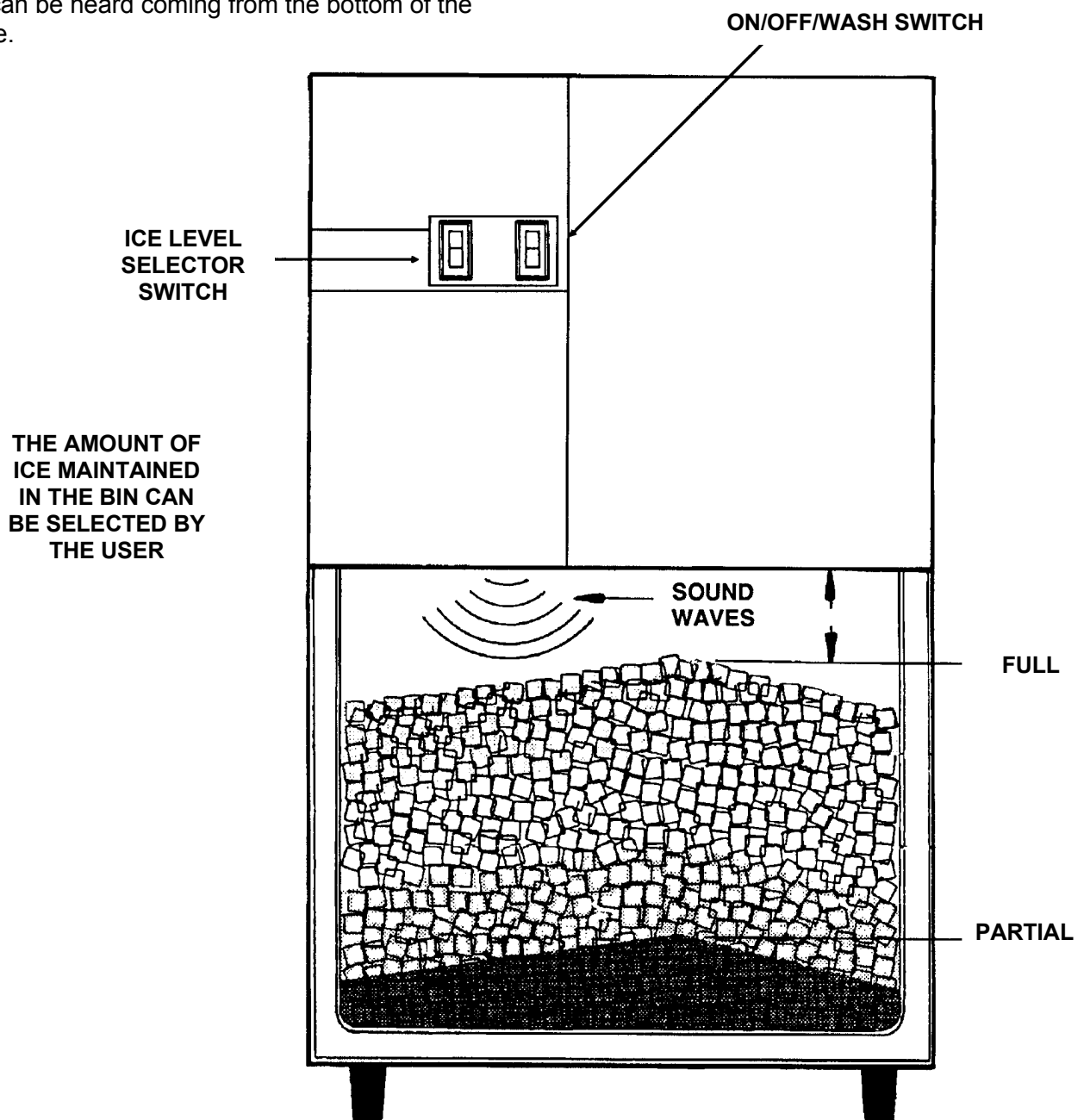

## COMPONENT DESCRIPTION

### Electric Water Inlet Valve

The water inlet solenoid valve fills the reservoir assembly with water. Excess water overflows out the overflow standpipe located at the back of the reservoir. This action fills and rinses the reservoir during each harvest cycle. The flow rate is .75 g.p.m.

### Water Distribution System

The water distribution system evenly supplies water to all cells of the evaporator plates. The water pump pumps water from the reservoir up the vertical tygon tube to the tee. From there water is channeled through the water manifold to the water distributors, above each evaporator plate, and from six holes within each distributor, water flows to the cells of each side of the evaporator plates. Gravity flow returns the unfrozen excess portion of water to the reservoir for recirculation.

### Reservoir

The reservoir, located below the evaporators, stores the inlet water charge, and collects the water that flows over the evaporator plates. Above the reservoir, but below the evaporators are the cube chutes, designed to retain any water splash from ice making or harvest. Most ice will be falling into the bin below the center evaporator.

### Strainer

A water strainer is located in the potable inlet water line before the water inlet solenoid valve. Clean the water strainer as needed.

### High Pressure Safety Control

This is a manual reset control that shuts down the icemaker, should the discharge pressure ever reach 350 PSIG.

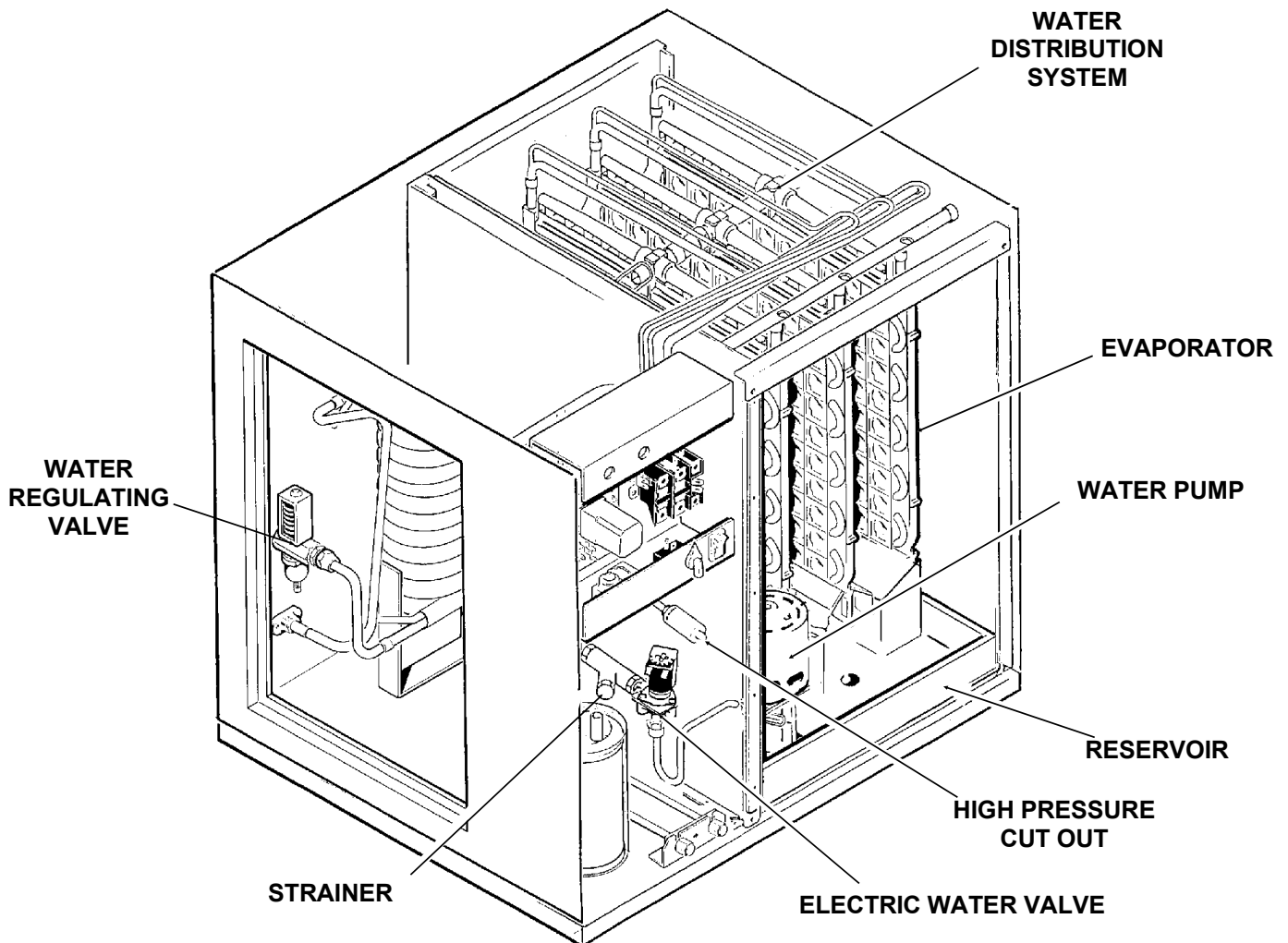

# CMS1002W

## SERVICE SPECIFICATIONS

---

When servicing a machine, it's helpful to compare that unit's operating characteristics to those of a new, clean, normally operating machine. What follows is that type of information:

### COMPONENTS

Timer: Makes one complete revolution in 8 minutes. The harvest time is factory preset at 2 ¼ minutes. The harvest time is adjustable as required.

Inlet Water Valve: Opens and admits ¾ gallon per minute during the harvest cycle.

Cube Size Control: Reverse acting temperature control, contacts close between 24<sup>0</sup>F. and 0<sup>0</sup>F.

High Pressure Safety Switch: Contacts open at 350 P.S.I.G.

Bin or Ice Level Control

Maximum Full Height	8" from the base of the ice machine.
Partial Fill Setting	21" - 22" from the base of the ice machine.
Maximum Storage Bin Interior Height	8' from the base of the ice machine.

### OPERATING CHARACTERISTICS

The values listed below are representative of values seen at a wide range of air and water temperatures and are for a normal cube size.

#### FREEZE CYCLE

Average Discharge Pressure	220 P.S.I.G.
Suction pressure at the end of the freeze cycle	26-23 P.S.I.G.
Freeze Time	13-15 minutes

#### HARVEST CYCLE

Average Suction Pressure	70-100 P.S.I.G.
--------------------------	-----------------

Harvest time is assumed to be 2.25 minutes. This can be adjusted to suit local conditions.

# CLEANING

A Scotsman Ice System represents a sizable investment of time and money in any company's business. In order to receive the best return for that investment, it MUST receive periodic maintenance.

Maintenance and Cleaning should be scheduled at a minimum of twice per year.

## CLEANING: ICEMAKER

### WARNING

Electrical power needs to be on when doing in place cleaning.

1. Remove front panel.
2. Switch the Wash/Off/Ice switch to OFF.
3. Remove the front liner.
4. Remove and discard all ice from the storage bin.
5. Locate the reservoir drain and drain the reservoir. If the reservoir doesn't drain completely, disconnect the pump hose attached to the water distributors and place the end of the hose in a bucket. Switch the Wash/Off/Ice switch to Wash, and allow the pump to discharge the rest of the water. Reattach the hose to the water distributors.
6. Mix 8 ounces of Scotsman Ice Machine Cleaner with 1 gallon of warm (95°F. - 115°F.) water and pour into the reservoir until full.
7. Switch the Wash/Off/Ice switch to "wash". Let

9. Switch the machine to "wash" and continue to add fresh water to flush residual cleaner from the system. Switch the Wash/Off/Ice switch off.
10. Sanitize the ice maker and bin, see "Sanitize Water System".
11. Replace the front liner.
12. Switch the Wash/Off/Ice switch back on.
13. Replace the front panel
14. Check the next batch of cubes to make sure all of the acid taste is gone.

### CAUTION

DO NOT use ice produced from the cleaning solution. Be sure none remains in the bin.

15. Remove and discard all ice from the storage bin, pour hot water into the storage bin to melt the cubes and also clean out the bin drain.
16. The unit is now ready for continued automatic operation.

	<p><b>WARNING</b> Scotsman Ice Machine Cleaner contains acids. These compounds may cause burns.</p> <p>If swallowed, DO NOT induce vomiting. Give large amounts of water or milk. Call Physician immediately. In case of external contact, flush with water.</p> <p><b>KEEP OUT OF THE REACH OF CHILDREN.</b></p>
-------------------------------------------------------------------------------------	-------------------------------------------------------------------------------------------------------------------------------------------------------------------------------------------------------------------------------------------------------------------------------------------------------------------

the unit operate for 30 minutes, then switch the unit off.

8. Drain the reservoir again (repeat step 5)

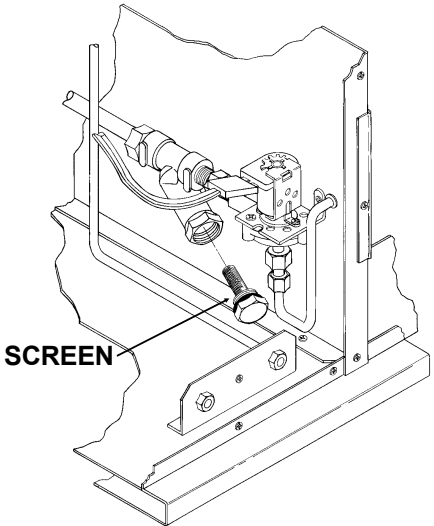
<p><b>Strainer:</b></p> <p>A water strainer is located in the water line before the inlet water solenoid valve. It is designed to catch large particles that may be in the water. To clean:</p> <ol style="list-style-type: none"> <li>1. Shut off water supply.</li> <li>2. Unscrew screen from strainer.</li> <li>3. Brush particles from screen</li> <li>4. Replace screen in strainer.</li> <li>5. Turn water supply back on.</li> </ol>	
----------------------------------------------------------------------------------------------------------------------------------------------------------------------------------------------------------------------------------------------------------------------------------------------------------------------------------------------------------------------------------------------------------------------------------------------	---------------------------------------------------------------------------------------

# CMS1002W

## CLEANING

### SANITIZE WATER SYSTEM

1. Remove and discard all ice from the bin.
2. Remove front panel.
3. Drain the reservoir
4. Prepare 2 gallons of an approved sanitizer solution in accordance with the instructions on the package, or use the following instructions for use of household bleach, if it meets local codes:  
Mix a sanitizing solution of 1 ounce of household bleach to 2 gallons of water.
5. Pour 1 gallon of the sanitizer into the ice maker reservoir.
6. Move the Wash/Off/Switch switch to "Wash", and allow the solution to circulate for a MINIMUM of 5 minutes.
7. Move the Wash/Off/Switch switch to "Off".
8. Remove the drain plug and drain the reservoir.
9. Using a clean sponge and the remainder of the sanitizer solution, wipe the interior of the evaporator cover and the inside of the storage bin,

taking care to wipe all surfaces that are normally in contact with ice.

10. Replace the evaporator cover. Replace the front panel.

11. Move the master switch to ON.

### SANITIZE ICE STORAGE BIN

*This procedure is to be done monthly*

1. Remove and discard all ice from the bin.
2. Switch the ice maker off.
2. Prepare 2 gallons of an approved sanitizer solution in accordance with the instructions on the package, or use the following instructions for use of household bleach, if it meets local codes: Mix a sanitizing solution of 1 ounce of household bleach to 2 gallons of water.
3. Using clean rubber gloves and a clean cloth, wipe all interior surfaces of the ice machine and ice storage bin with the sanitizing solution. Immerse any small parts in the sanitizing solution and wash the parts, flushing the solution thoroughly in, over and through all parts and surfaces of the parts being cleaned.
4. Allow to air dry.
5. Switch the ice machine back on.

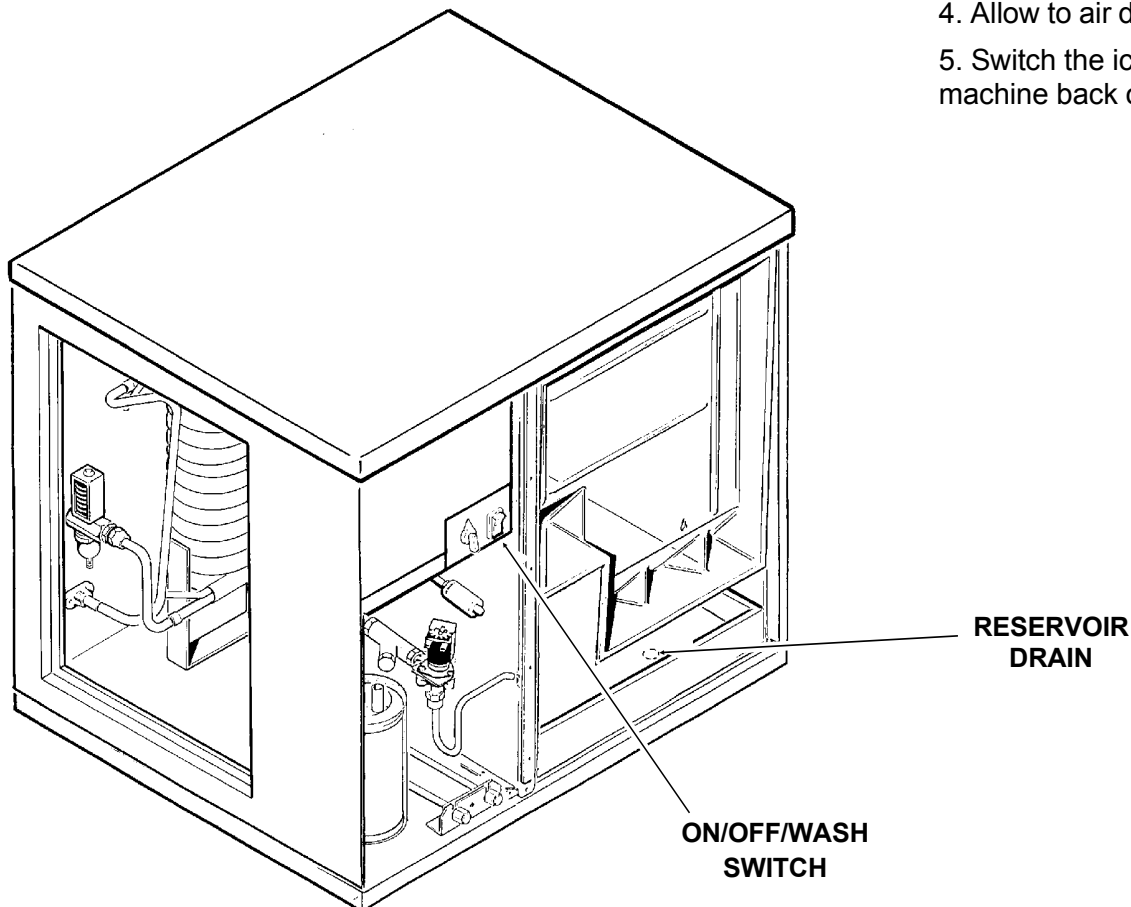



## SERVICE DIAGNOSIS

SYMPTOM	POSSIBLE CAUSE	PROBABLE CORRECTION
No ice, machine does not run	1. No electrical power	1. Restore power
	2. Circuit breaker tripped or fuse blown	2. Reset breaker or replace fuse, check for electrical fault.
	3. High pressure control open.	3. Reset HPC, check fan motor for proper operation, and condenser coil for dirt.
	4. ice level control holding machine off	4. Check ice level control circuit. See page 19.
	5. High temp. cut out open	5. Hot gas valve leaks thru, replace hot gas valve
	6. Timer switch open	6. Replace timer
	7. Master switch open	7. Check or replace switch.
	8. Circuit board open	8. Replace circuit board.
No ice, compressor does not run, rest of ice machine does.	1. Open contactor coil	1. Replace contactor
	2. Thermostatic Expansion valve clogged or does not open.	2. Check/replace TXV.
No ice, no water over evaporators	1. Water pump does not pump	1. Check/replace water pump
	2. No water in reservoir	2. Check/replace water inlet valve.
No ice, everything runs	1. Too much heat load	1. Check for slow leak thru of water inlet valve.
	2. Low on refrigerant	2. Check pressures, if low find/repair leak; weigh in charge.
	3. Suction pressure too high	3. Defective compressor - replace
Low ice production	1. Too much heat load.	1. Check condenser air inlet temperature. Check water temperature.
	2. Compressor inefficient.	2. Replace compressor
	3. Non condensable gasses in refrigeration system.	3. Check head pressure, if very high, and no other reason is suspected, replace refrigerant charge.

# CMS1002W

## SERVICE DIAGNOSIS

SYMPTOM	POSSIBLE CAUSE	PROBABLE CORRECTION
Low ice production	4. High head pressure, a result of a dirty condenser	4. Clean water circuit of condenser
	5. Hot gas valve leaks thru	5. Replace hot gas valve
	6. High discharge pressure	6. If possible, reduce condenser water inlet temperature.
No ice falling in bin, unit frozen up	1. Cube size control will not close	1. Check temp. of suction line, cube size control will not close if temp. too high. If temp. low enough, replace cube size control
	2. Timer motor open	2. Replace timer
	3. Plug in relay contacts open	3. Replace relay
	4. Not enough time during the harvest cycle to drop all ice	4. Adjust timer for more harvest time
	5. Cube size wrong	5. Adjust cube size
	6. Hot gas valve restricted.	6. Replace hot gas valve.
	7. Not enough water to help harvest.	7. Check for restriction of water supply.
	8. Head pressure too low	8. Check water reg./pressure control valve. Check for low refrigerant charge.
Ice maker stuck in harvest cycle	1. Relay coil open	1. Replace relay
	2. Timer stuck in harvest cycle	2. Check for power to timer motor, if power replace timer, if no power to timer motor, replace relay.
	3. Timer microswitch N.O. contacts will not close.	3. Replace timer.
Ice is mal-formed	1. Shortage of water	1. Check for restriction of water supply. Check for leak.
	2. Evaporator water passages restricted.	2. Clean ice maker.
	3. Cube size set wrong	3. Adjust cube size control
Water overflows from reservoir into bin.	1. Restricted sump drain	1. Repair drain
	2. Inlet water valve lets in too much water	2. Replace valve

## SERVICE DIAGNOSIS: Ice Level Control Circuit

CONDITION	DETERMINE CAUSE	PROBABLE CORRECTION
Ice Machine does not run, it has power to it, the high pressure control is closed, the on/off switch is set to ON.	A. Listen for a ticking sound from transducer.	If no noise, go to C. If there is a noise, check for a light on the board (models built after 4/93). If there is a light on, check relay contacts N.O. and COM. The contacts should be CLOSED. If closed, go to D. If not, replace the board. If light is off, or prior model, go to B.
	B. Open bin door and twist transducer 1/4 turn and pull out. <b>DO NOT UNPLUG with power connected.</b> Examine the transducer, the inside must be clean and dry.	If the inside of the transducer (above screen) was wet, replace it. Set bin level to FULL and aim at an object about 1-3 feet away. Machine should restart, if not go to D.
	C. <b>Check power to bin level control board.</b>	Should be 12 volts from transformer, if not replace transformer. If there is power go to D.
	D. <b>Disconnect electrical power</b> and test ice machine circuit by attaching a jumper wire between bin thermostat posts on circuit board part no. 12-1912-01 (the circuit board with the timer on it). Reconnect power.	If machine does not start <b>go back to machine circuit.</b> If machine starts, disconnect electrical power, remove jumper wire and reconnect electrical power. Then go to E.
	E. Transducer or ice level board assembly defective.	Replace transducer. Set bin level to FULL and aim at an object about 1-3 feet away. Machine should restart. If this does not repair unit, replace the board.
Machine runs, makes ice, switches on and off, but ice level cannot be controlled.	Ice level switch may be defective. On boards with a light, check by moving switch & watching light.	Replace ice level switch
Machine runs, but will not shut off.	Board relay stuck closed. Check relay.	If COM and N.O. are closed when power is off, replace board. If open, go to B above.

PARTIAL VIEW OF CIRCUIT BOARD 12-1912-01

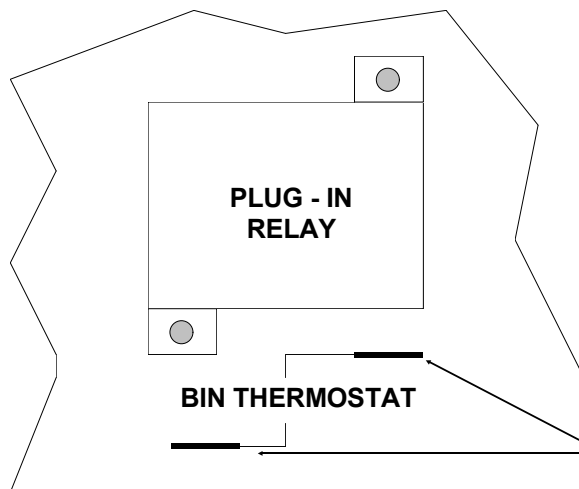

### **⚠️ WARNING**

Electrical Shock Hazard Can Cause Personal Injury.  
 Disconnect Power Before Servicing.  
 Bin Thermostat Posts at Line Voltage.

POSTS MENTIONED IN "D" ABOVE

# CMS1002W

## REMOVAL AND REPLACEMENT

### TRANSDUCER

1. Disconnect electrical power BEFORE removing transducer.
2. Open bin door and locate the transducer socket.
3. Twist inner portion of transducer counter-clockwise and push up gently.
4. Pull transducer down until plug connection is accessible.
5. Unplug transducer and remove from the machine.
6. Reverse steps 1-5 to reassemble.

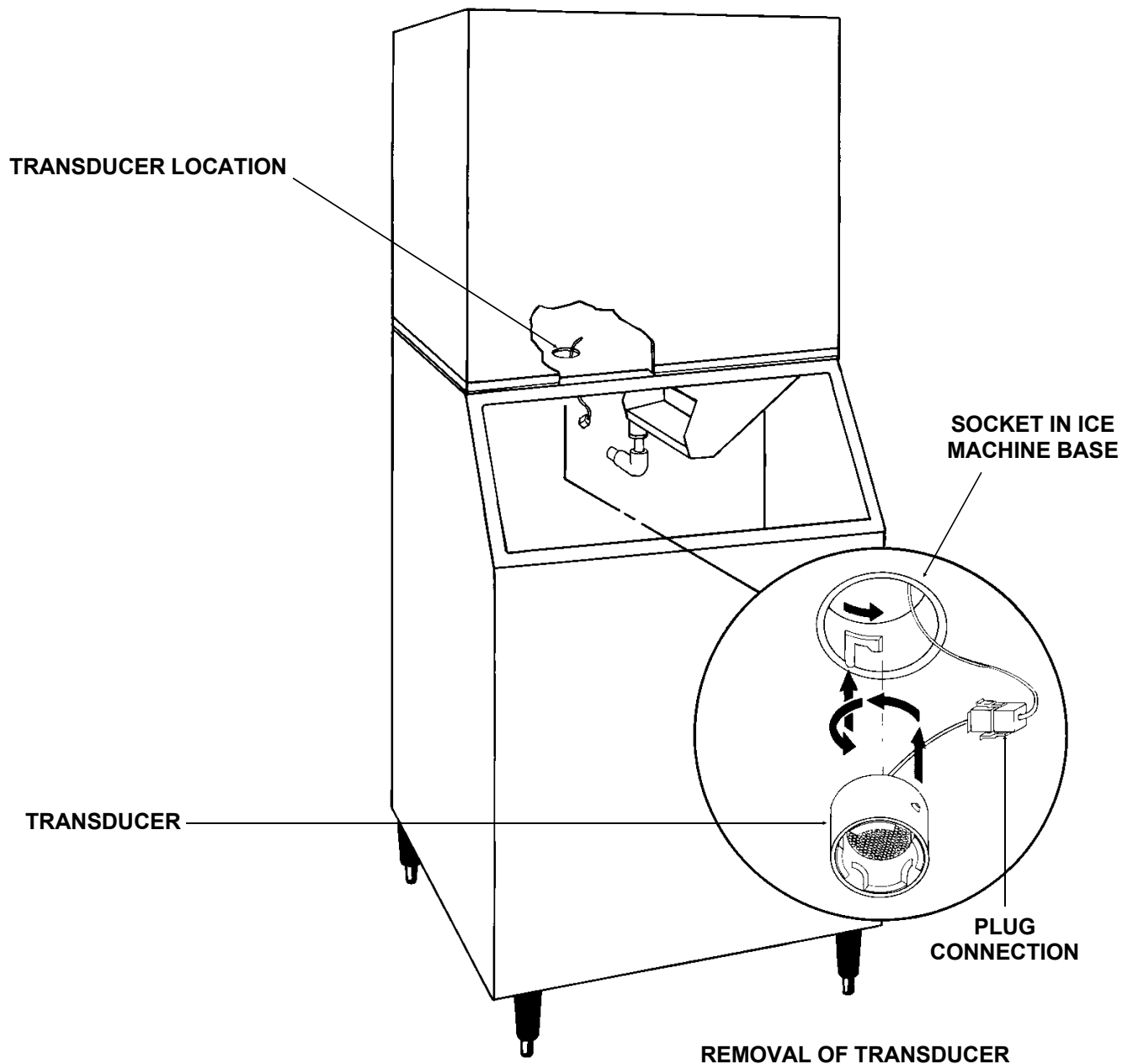

## REMOVAL AND REPLACEMENT

////////////////////WARNING////////////////////////////////////

Disconnect electrical power before beginning.

////////////////////////////////////

### Cube Size Control

To remove the cube size control:

1. Remove front panel.
2. Remove cover from control box.
3. Trace capillary tube, from the cube size control to the refrigerant suction line.
4. Remove the coiled capillary tube bulb from the tube well on the suction line.
5. Remove electrical leads from the cube size control.
6. Remove screws and the cube size control. To replace the cube size control, reverse the removal procedure. Be certain to re-insulate the cube size control bulb.

**Water Distributor Tubes And Manifold Tubes**  
To remove the water distributor tube and manifold tube:

1. Pull out to unsnap catches and remove the front panel.
2. Remove the evaporator cover.
3. Slide the water distributor tube to the front about 1/8-inch along the top of the evaporator plate, until the water distributor tube can be unsnapped from the flexible notch and lifted upward to the right side.
4. Unsnap and disconnect water distributor tubes from the water manifold section. To replace the water distributor tubes and manifold tubes, reverse the removal procedure. BE SURE the notches in the water manifold tubes properly engage the alignment keys in the tee. BE SURE the water distributor tube is securely fastened at the notch at both sides of the evaporator plate. Check identical attachment for the left water distributor tube and notch; also, that the distributor/manifold connections at the top center of each evaporator plate is snug against the top of the plate.

### Inlet Water Solenoid Valve Assembly

To remove the inlet water solenoid valve assembly:

1. Shut OFF water supply to machine.

**ELECTRICAL CORD**

**SOLENOID VALVE**

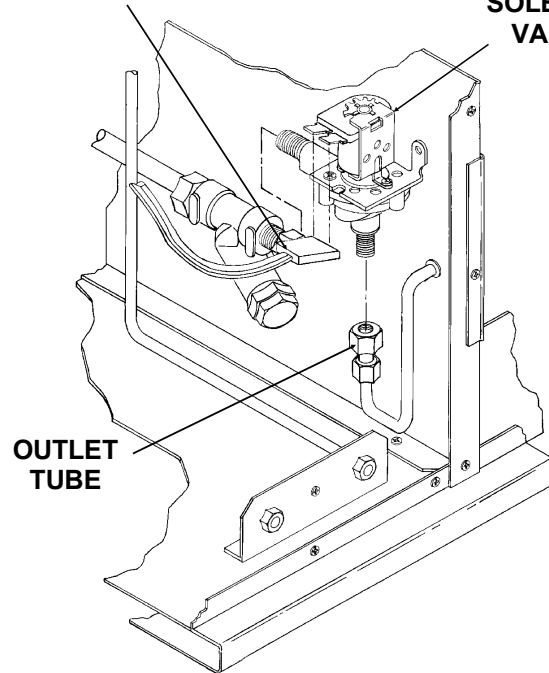

### REMOVAL OF THE INLET WATER VALVE

2. Loosen and remove outlet water line from the inlet water solenoid valve assembly.
3. Remove screws and pull the water solenoid valve out to gain access.
4. Pull electrical cord connection from solenoid coil terminals.
4. Remove inlet water fitting from the water solenoid valve. To replace the inlet water valve assembly, reverse the removal procedures.

# CMS1002W

## REMOVAL AND REPLACEMENT

////////////////////**WARNING**////////////////////

Disconnect electrical power before beginning.

////////////////////

### Water Pump

1. Remove front panel.
2. Remove evaporator cover.
3. Unplug water pump electrical connection.
4. Remove thumb screw retaining pump to cross brace.

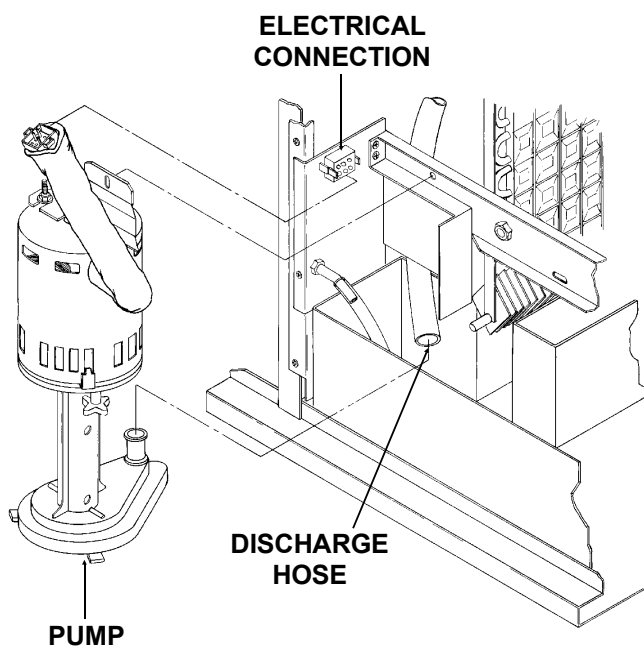

### REMOVAL OF THE WATER PUMP

5. Pull pump partially out of reservoir and remove discharge hose.
6. Remove two nuts holding pump cover to pump body; separate the two and remove the pump from the icemaker.
7. Reverse to reassemble.
8. Replace all panels.
9. Reconnect electrical power.

### Hot Gas Valve

1. Remove the side service panel, and top panel if possible.
2. Discharge and recover the refrigerant from the system.
3. Remove the electrical connections from the coil of the valve
4. Cut out or unsweat the valve at the tubing connections, remove the valve from the icemaker.
5. Install the new valve, wrap it in wet cloths or other efficient heat sink material.
6. Sweat the tubing connections to the valve.
7. Connect the electrical wires to the terminals of the valve coil.
8. Weigh in the nameplate charge.
9. Replace all panels removed for service.
10. Reconnect electrical power.

### Thermostatic Expansion Valve

1. Remove the side service panel, and top panel if possible..
2. Discharge and recover the refrigerant from the system.
3. Locate the TXV sensing bulb on the suction line, unwrap the insulation and remove the bulb from the clamp.
4. Cut out or unsweat the old TXV from the tubing connections.
5. Wrap the new TXV body in wet cloths or other efficient heat sink material.
6. Sweat in the new valve. Do not overheat.
7. Re-attach the TXV bulb to the suction line in the same place as the original. Be certain to re-insulate.
8. Weigh in the nameplate charge.
9. Replace all panels removed for service.
10. Reconnect electrical power.