

CMS1202 SERVICE PARTS

This parts lists shows the service parts for the CMS1202 air cooled and the CMS1202 water cooled.

Check the model number of the machine to be certain of obtaining the correct part.

Included at the back of the parts list are the wiring diagrams.

Table of Contents

Cabinet	Page 2
Refrigeration System	Page 3
Air and Water Cooled Parts	Page 4
Water System	Page 5
Control Box	Page 6
BH900 Bin	Page 7
Wiring Diagrams	Page 8

CMS1202 SERVICE PARTS

CABINET PARTS

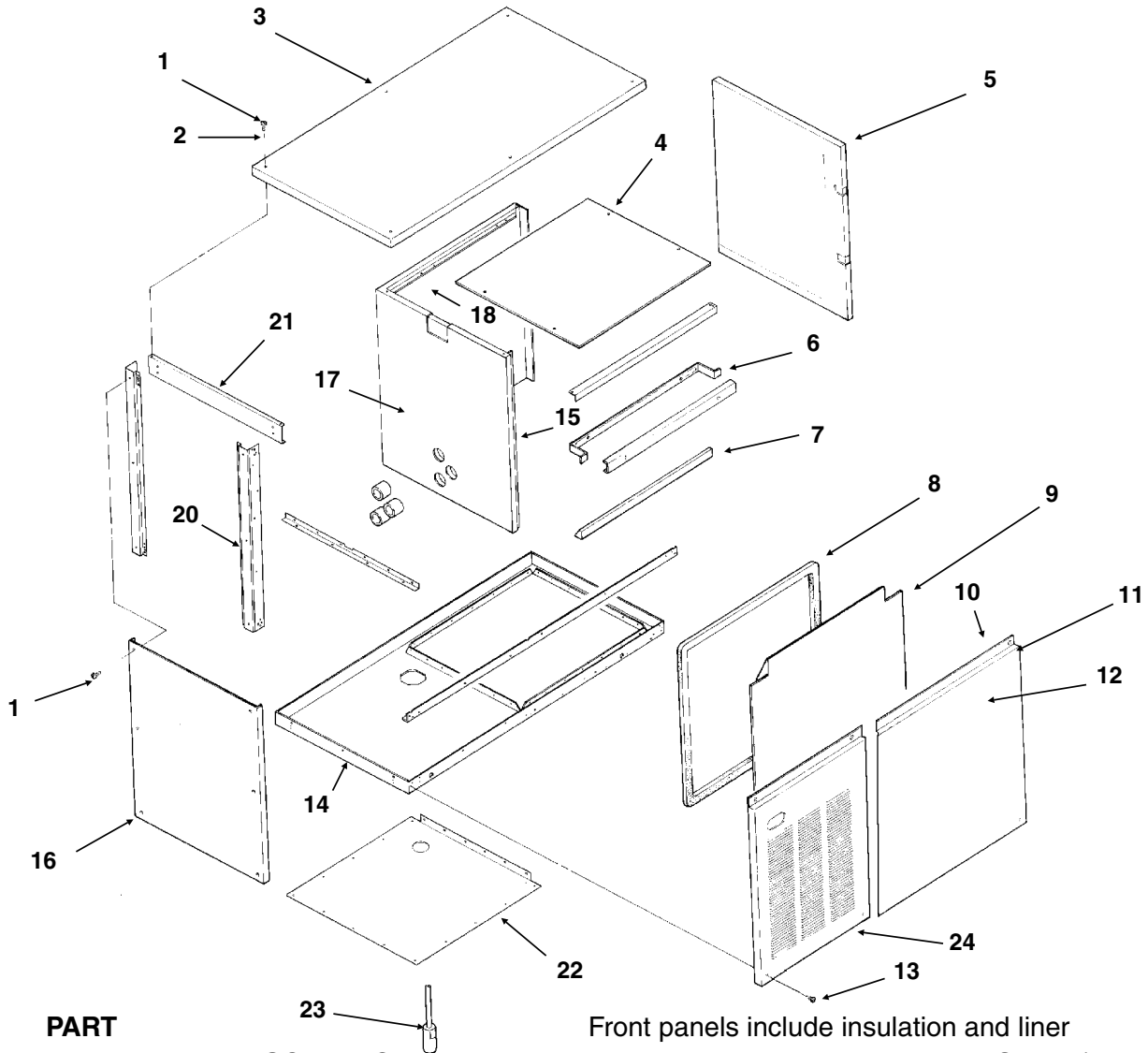

Front panels include insulation and liner

ITEM NUMBER	PART NUMBER	DESCRIPTION
1	03-1531-01	Screws
2	03-1417-27	Washers
3	A35074-001	Panel top (enamel)
	A35074-002	Panel top (stainless)
4	A33364-001	Liner top
5	A29164-003	Right panel (enamel)
	A29164-002	Right panel (stainless)
6	A29204-001	Brace front
7	02-2532-01	Liner cap
8	13-0595-00	Gasket (order per foot)
9	02-2795-01	Liner, front panel
10	03-1678-01	Speed clip (B model)
11	A35080-021	A model front panel (enamel)
	A35080-022	A model front panel, (stainless)
	A35401-022	B model right front panel, stainless
	A35401-021	B model right front panel, painted
12	03-1678-04	Thumb Screw (B model)
13	03-1678-03	Screw retainer (B model)
14	02-3252-01	Plastic Bumper (B model)
15	15-0711-01	Emblem
16	03-1404-19	Screws
17	A35110-001	Base assembly
18	02-2533-01	Liner, left side
19	A35075-001	Left side panel, enamel
20	A35075-002	Left side panel, stainless
21	no number	Retainer
22	02-2531-01	Liner back
23	02-2534-01	Right side liner
24	A35069-001	Corner post
	A35066-001	Brace
	02-3151-01	Plastic cover
	A34908-021	Transducer
	A35400-001	B model left frnt panel, painted

CMS1202 SERVICE PARTS

REFRIGERATION SYSTEM

ITEM NUMBER	PART NUMBER	DESCRIPTION	ITEM NUMBER	PART NUMBER	DESCRIPTION
1	A35122-001	Evap. manifold assy	10	12-2290-22	Hot gas valve
2	A31816-001	Manifold assy		02-3231-03	Hot gas valve filter
3	16-0816-21	Expansion valve	11	16-0817-01	Accumulator
	13-0617-51	O-Ring	12	16-0560-00	Valve core
	02-2920-01	Foam insulation	13	16-0563-00	Valve cap
4	02-2426-02	Drier	14	12-2300-02	Hi temp cut out
5	03-1405-20	Screw	15	A30296-020	Evaporator plate
6	03-1407-07	Washer	16	11-0465-21	Hi press. cut out (A.C.)
7	18-2200-27	Sleeve		11-0463-22	Hi press. cut out (W.C.)
8	18-2200-28	Grommet	17	16-0790-01	Distributor, included in item 1.
9	18-8600-02	Compressor, single phase (CRG3-0250-PFV-270)			
	18-8600-03	Compressor, three phase (CRG3-0250-TF5-270)			
	no number	Comp. overload (internal)			

Replacement compressors include crankcase heater, not used on this model.

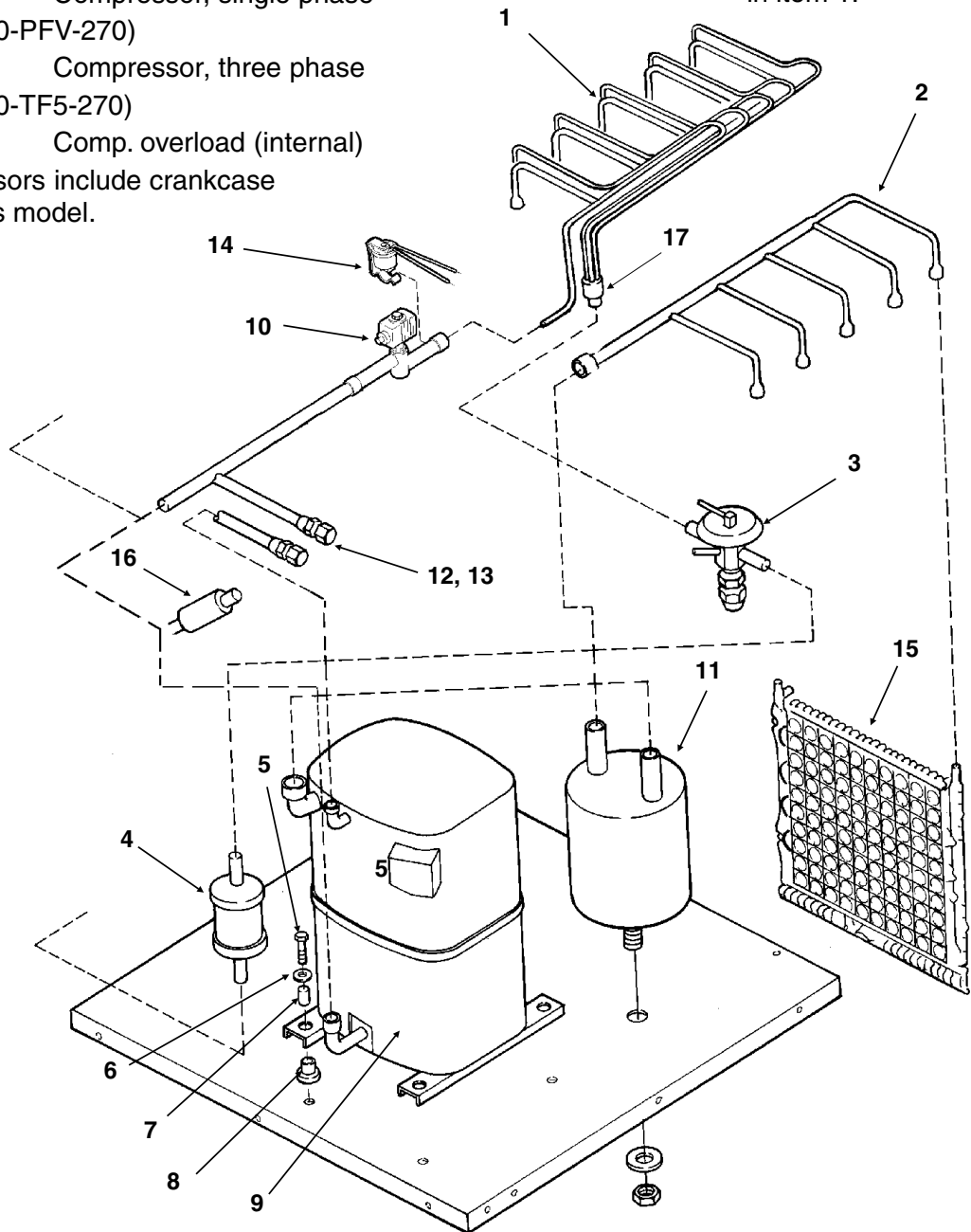

CMS1202 SERVICE PARTS

CONDENSING ASSEMBLIES

AIR COOLED MODELS

ITEM NUMBER	PART NUMBER	DESCRIPTION
1	A35103-001	Fan Bracket
2	18-5105-02	Fan Motor
3	18-8503-01	Fan Blade
4	A35104-001	Condenser Shroud
5	18-8502-01	Condenser
6	02-3164-01	Filter
7	A35102-001	Condenser divider

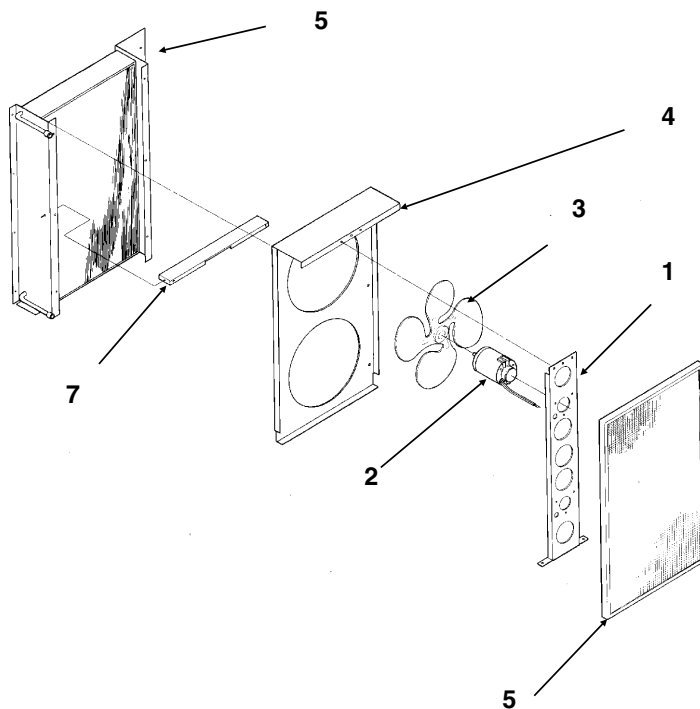

WATER COOLED MODELS

ITEM NUMBER	PART NUMBER	DESCRIPTION
1	11-0424-21	Water Regulator Valve
2	18-6302-01	Condenser, Water Cooled
3	03-1407-05	Washer
4	03-0571-01	Screw
5	A35070-001	Left back panel
6	02-2628-01	Receiver
7	A31828-001	Drain casting

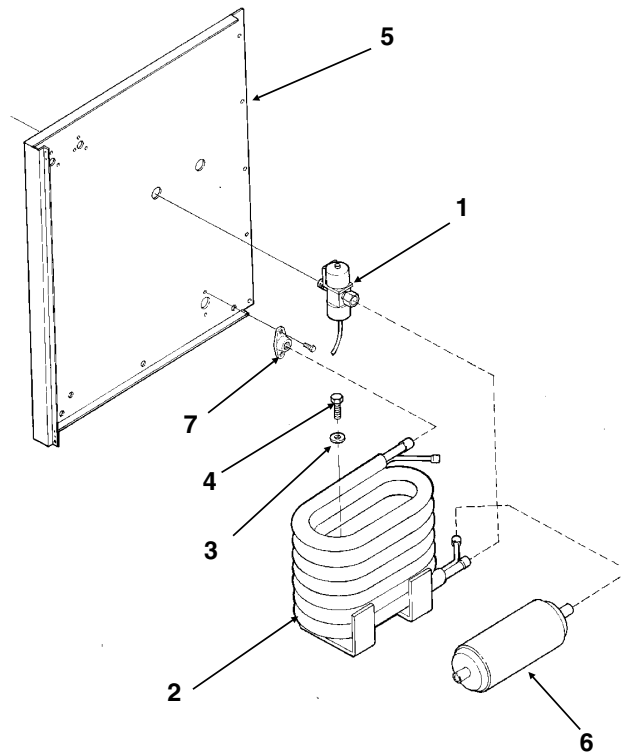

CMS1202 SERVICE PARTS

WATER SYSTEM

ITEM NUMBER	PART NUMBER	DESCRIPTION
1	02-2521-01	Long water manifold
2	02-2519-01	Tee
3	A29703-001	Short water manifold
4	02-2527-01	Water dist. tube
5	02-2814-01	Clamp
6	A29730-001	Water Tube Assy
7	A30761-020	Sump Assembly
8	02-1530-01	Clamp
9	02-1800-01	Clamp
10	A30666-001	Pump Bracket
11	03-0571-01	Screw

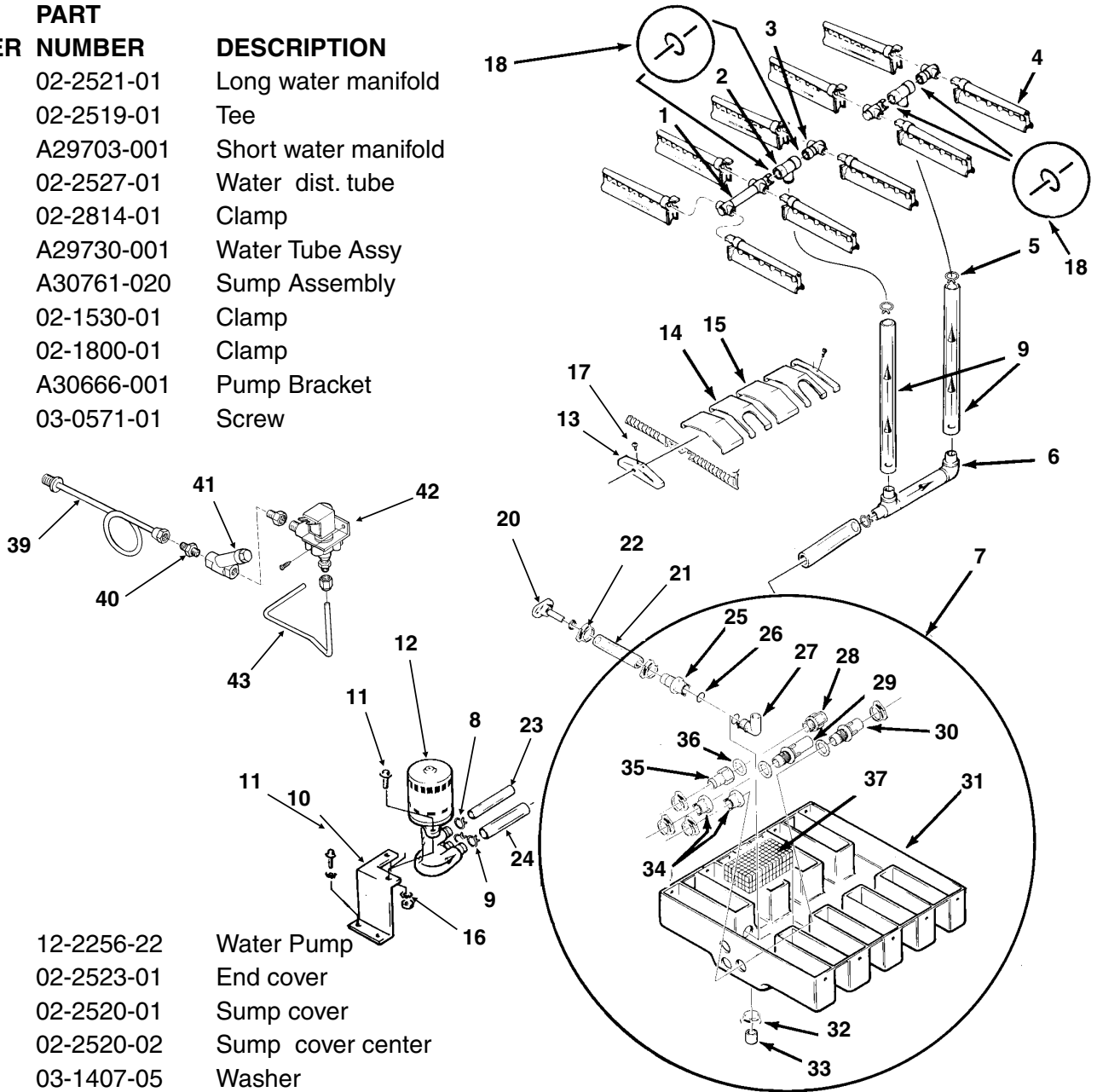

12	12-2256-22	Water Pump
13	02-2523-01	End cover
14	02-2520-01	Sump cover
15	02-2520-02	Sump cover center
16	03-1407-05	Washer
17	03-1531-01	Screw
18	13-0617-48	O-ring
19	13-0674-07	Hose (18.5")
20	A31757-002	Drain
21	13-0674-07	Tube, drain (7")
22	02-2814-12	Hose clamp
23	13-0674-07	Tube, need 6.25"
24	13-0674-08	Tube, need 6.6"
25	02-2606-01	Female tube
26	13-0617-02	O-ring
27	02-2125-01	Elbow
28	A29342-001	Overflow
29	02-2792-01	Pick Up tube

30	02-2793-01	Inlet tube
31	no number	sump pan
32	02-1530-01	Clamp
33	13-0796-01	Rubber cap
34	02-2791-01	Water inlet nut
35	02-2606-01	Female tube
36	13-0617-02	O-ring
37	A30760-001	Screen
39	A35119-001	Water inlet assy.
40	16-0791-01	Half unio
41	16-0162-00	Strainer
42	12-1646-04	Inlet water valve
43	A35117-001	Tube

CMS1202 SERVICE PARTS

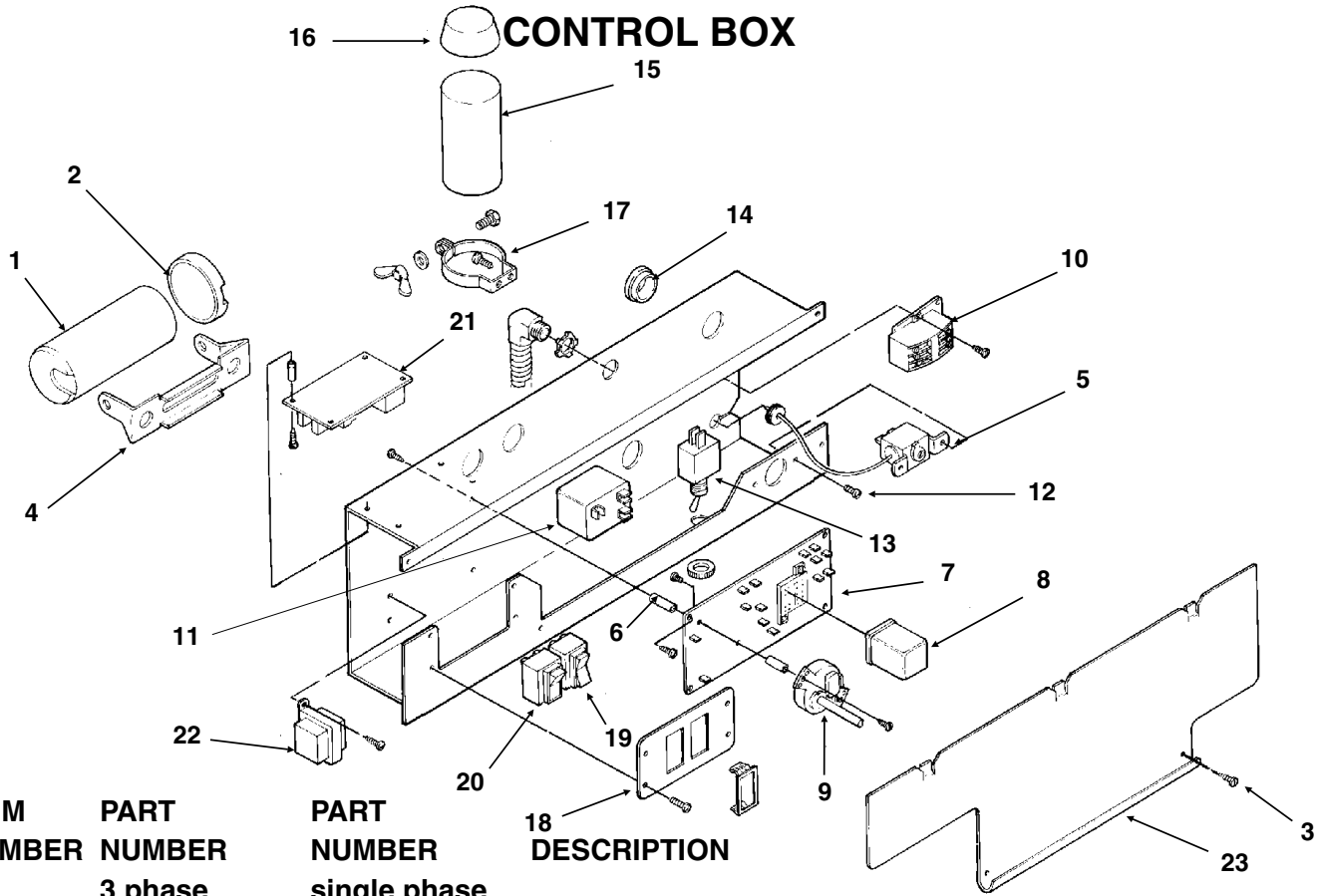

ITEM NUMBER	PART NUMBER	PART NUMBER	DESCRIPTION
	3 phase	single phase	
1	-	18-1901-48	Start Capacitor
2	-	18-8702-01	Start Cap. Cap
3	-	03-1638-03	Screw
4	-	18-2200-39	Start cap. bracket
5	11-0351-22	same	Cube Size Control
6	02-2242-02	same	Stand off
7	12-1912-01	same	Circuit board
8	12-1879-03	same	Relay
9	12-1980-22	same	Timer & Switch
10	12-0739-02	12-2469-02	Contactor
11	-	18-1903-46	Potential Relay (not illustrated)
12	03-1403-17	same	Screw
13	12-0426-01	same	Comp. Switch
14	-	12-1213-12	Snap busing
15	-	18-1902-27	Run capacitor
16	-	13-0666-00	Terminal cover
17	-	A34314-001	Run Cap Bracket
18	02-3173-01	same	Switch plate
19	12-2414-01	same	Wash- Off - Ice switch
20	12-2411-01	same	Bin ice level switch
		12-2402-01	Wire harness, bin level switch to board.
21	12-2376-21	same	Ice level control circuit board
22	12-2285-22	same	Transformer
23	A35082-001	same	Control box cover

The Fan Pressure Control is located behind the control box. 11-0426-22 is the part number.

CMS1202 SERVICE PARTS

BH900 ICE STORAGE BIN

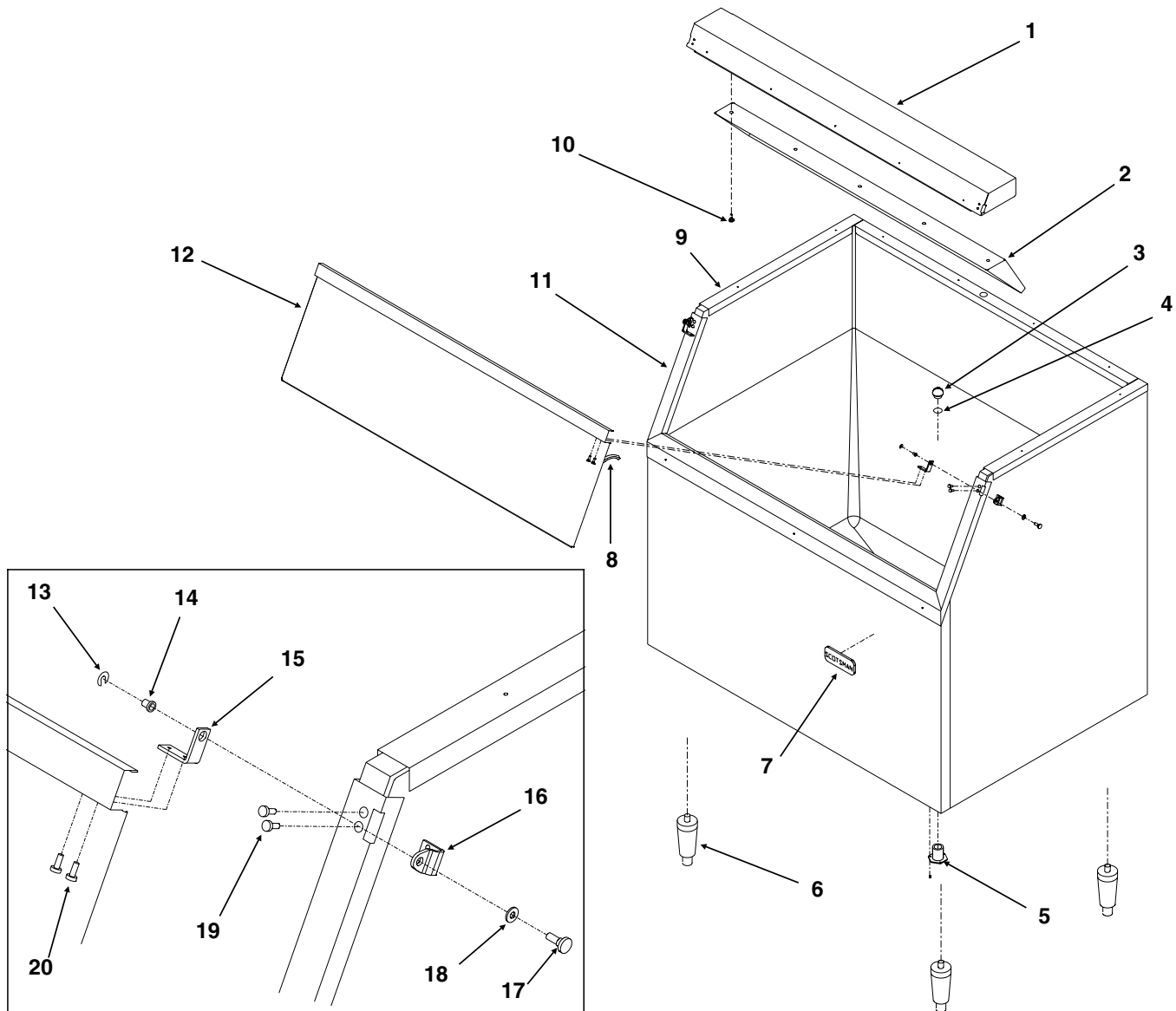

ITEM NUMBER	PARTS NUMBER	DESCRIPTION
1	A35322-020	Canopy Assembly
2	A35152-001	Ice Baffle
3	02-2809-01	Drain Top
4	13-0617-11	O-ring
5	02-3201-01	Drain casting
6	KLP2E	Leg Kit, Black
	KLP2S	Leg Kit, Nickel Plated
7	15-0711-01	Emblem
8	13-0595-00	Door gasket(6.25' reg.)
9	19-0503-04	Bin gasket
10	03-0727-11	Baffle screw
11	A35275-001	Door frame assy.
12	A35323-020	Door with gasket
13	03-1539-09	"E" ring

ITEM NUMBER	PARTS NUMBER	DESCRIPTION
14	02-2380-01	Hinge bushing
15	02-3195-01	Door hinge
16	02-3196-01	Bin hinge
17	02-2806-01	Shoulder screw
18	02-2380-02	Spacer
19	03-1403-29	Screw 10-24
20	03-1403-24	Screw 10-24

CMS1202 SERVICE PARTS

208-230/60/3 Air Cooled

A35439-003

THIS UNIT MUST BE GROUNDED
USE COPPER CONDUCTORS ONLY

SEE NAMEPLATE FOR
POWER SUPPLY VOLTAGE
AND MAX. FUSE SIZE
SEE NOTE \triangle

CAUTION:

MORE THAN ONE DISCONNECT MEANS
MAY BE REQUIRED TO DISCONNECT
ALL POWER TO THIS UNIT.

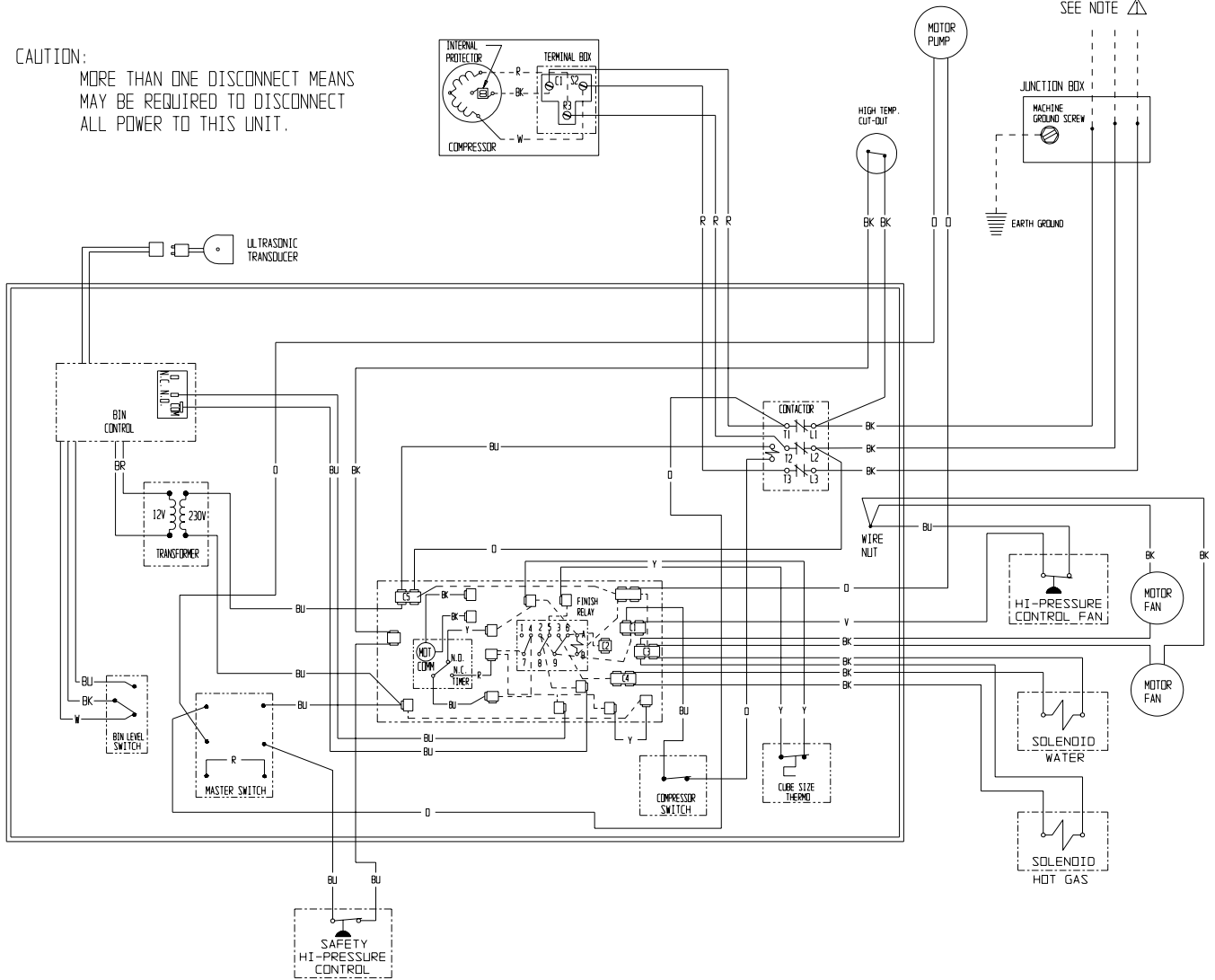

CMS1202 SERVICE PARTS

208-230/60/3 Air Cooled

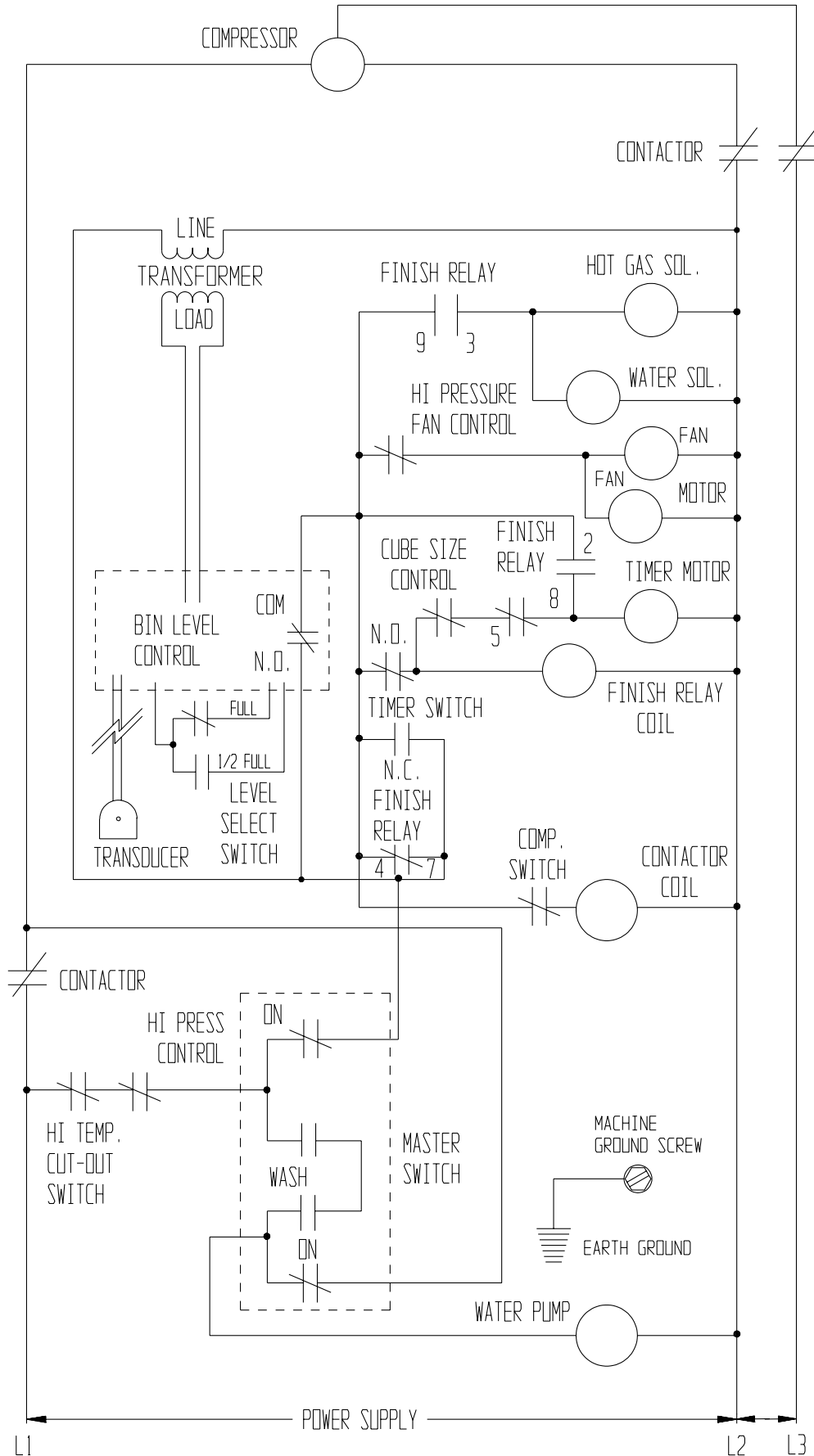

CMS1202 SERVICE PARTS

208-230/60/1 Air Cooled

A35303-032

THIS UNIT MUST BE GROUNDED
USE COPPER CONDUCTORS ONLY

NOTE:
▲ DASHED LINES INDICATE FIELD WIRING WHICH MUST BE
INSTALLED IN ACCORDANCE WITH THE NATIONAL ELECTRICAL
CODE AND ALL STATE AND LOCAL CODES.

LINE VOLTAGE 208/230/60/1
SEE NAMEPLATE FOR
MAX. FUSE SIZE
SEE NOTE ▲

CAUTION:
MORE THAN ONE DISCONNECT MEANS
MAY BE REQUIRED TO DISCONNECT
ALL POWER TO THIS UNIT.

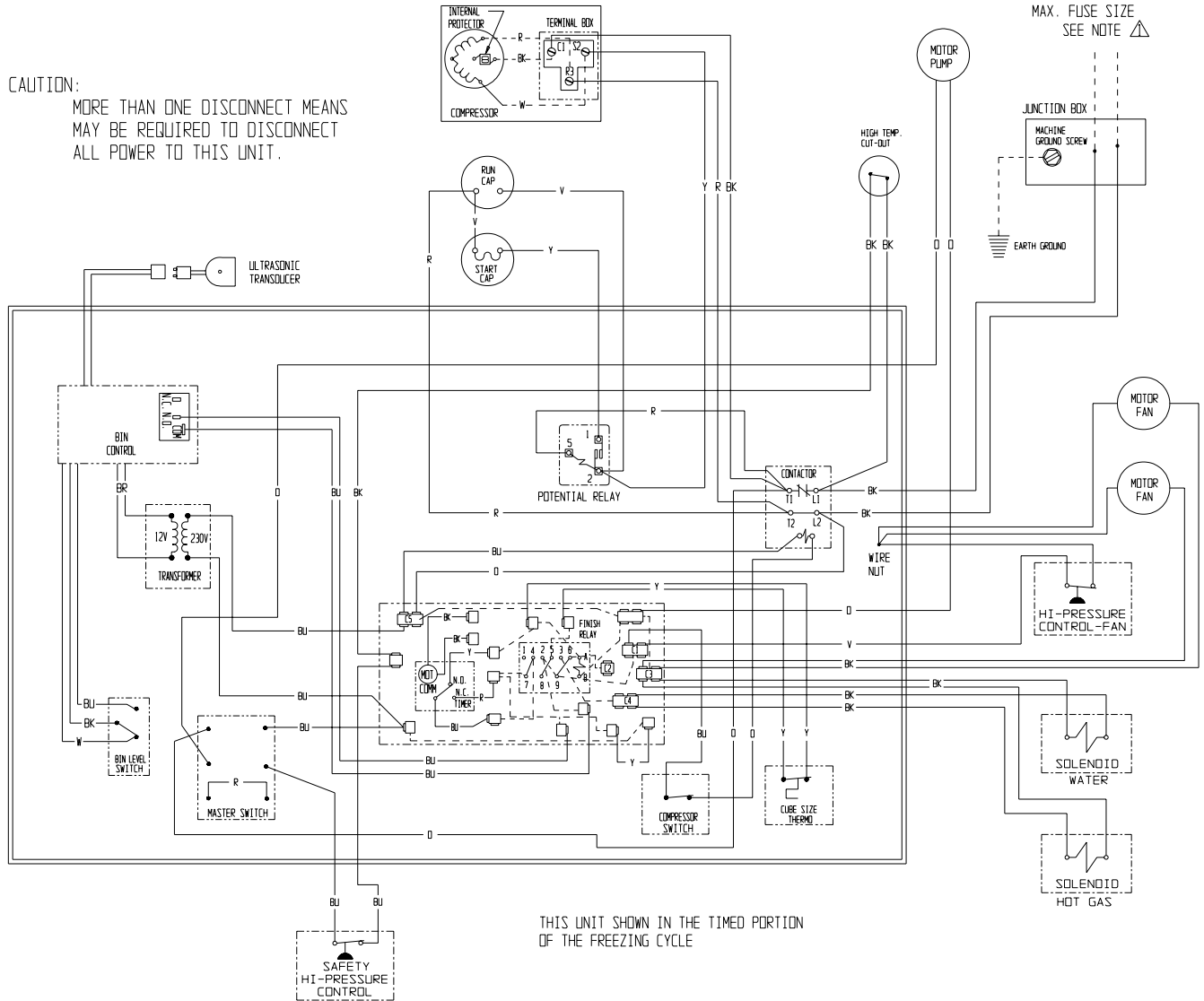

CMS1202 SERVICE PARTS

208-230/60/1 Air Cooled

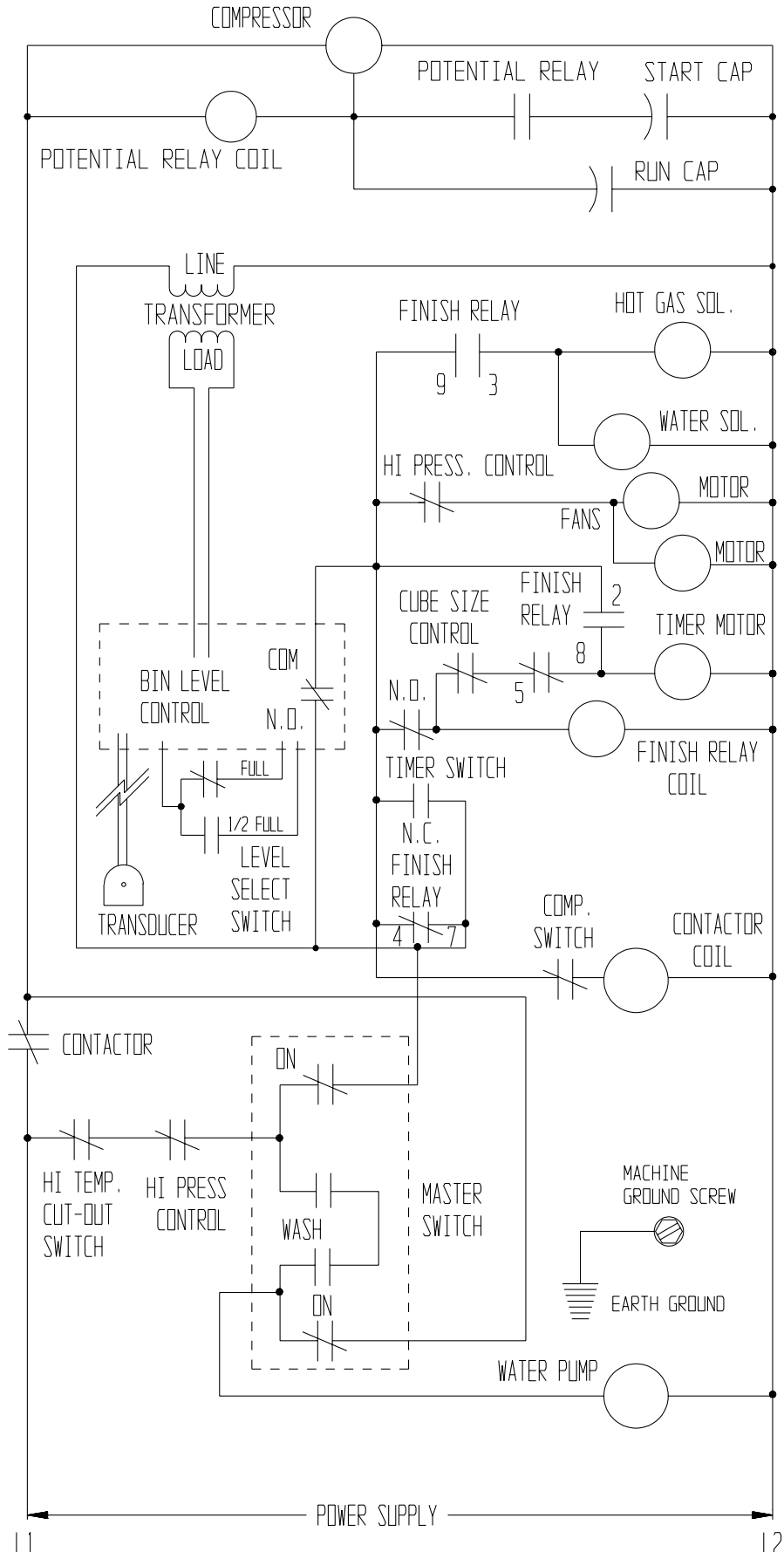

CMS1202 SERVICE PARTS

208-230/60/3 Water Cooled

A35440-003

THIS UNIT MUST BE GROUNDED
USE COPPER CONDUCTORS ONLY

CAUTION:

MORE THAN ONE DISCONNECT MEANS
MAY BE REQUIRED TO DISCONNECT
ALL POWER TO THIS UNIT.

SEE NAMEPLATE FOR
POWER SUPPLY VOLTAGE
AND MAX. FUSE SIZE
SEE NOTE Δ

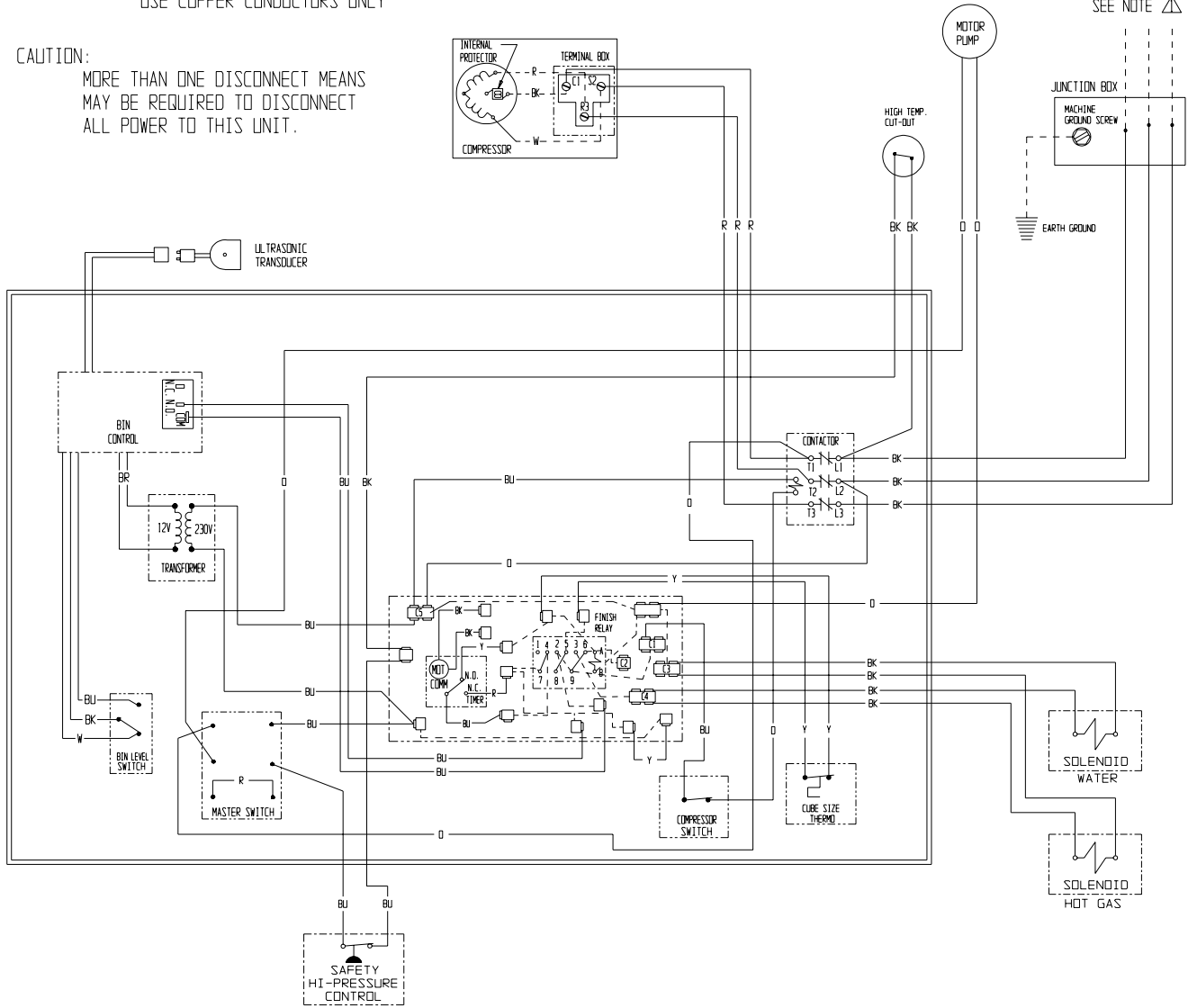

CMS1202 SERVICE PARTS

208-230/60/3 Water Cooled

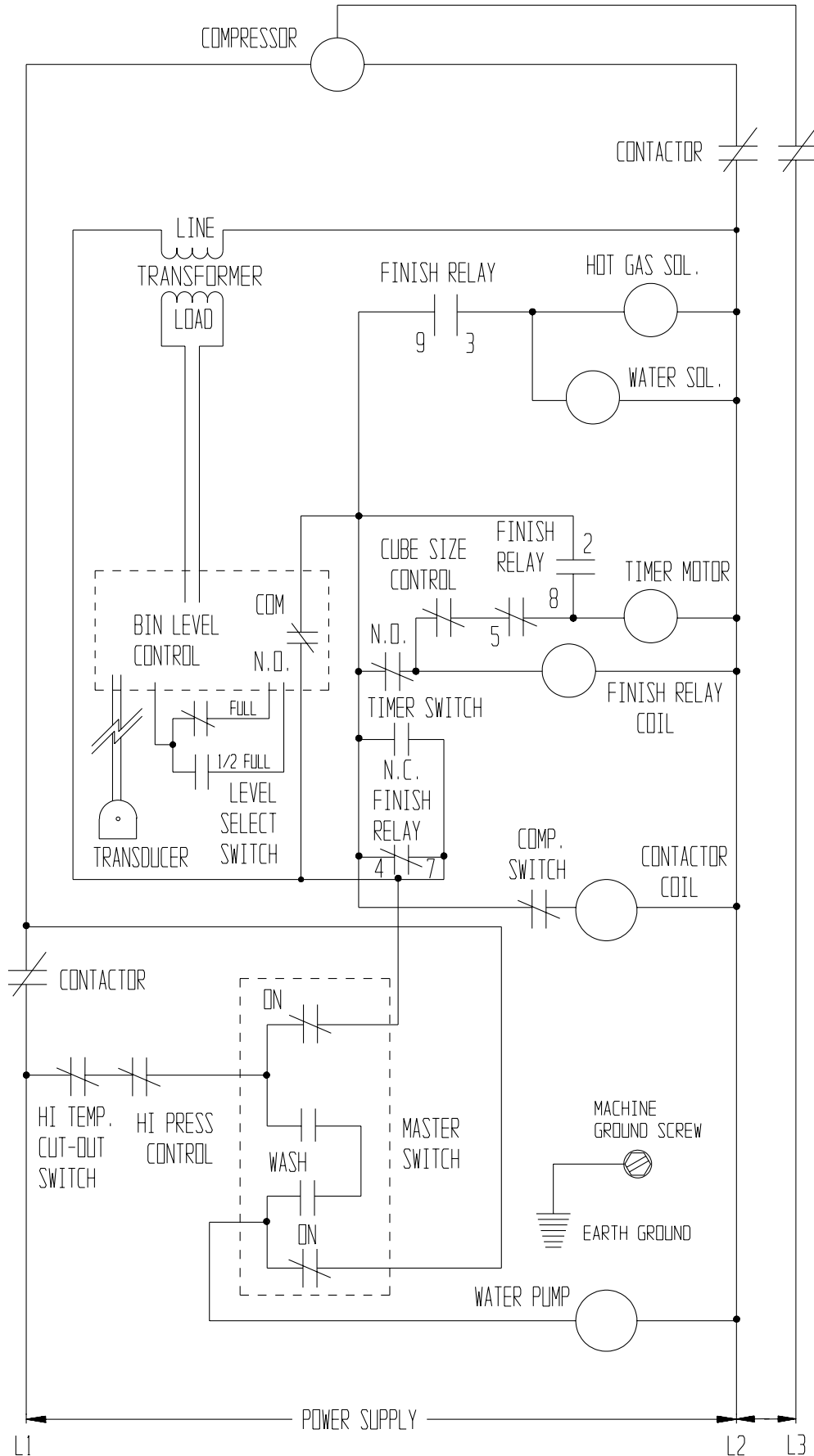

CMS1202 SERVICE PARTS

208-230/60/1 Water Cooled

NOTE:
 ▲ DASHED LINES INDICATE FIELD WIRING WHICH MUST BE INSTALLED IN ACCORDANCE WITH THE NATIONAL ELECTRICAL CODE AND ALL STATE AND LOCAL CODES.

A35304-032

THIS UNIT MUST BE GROUNDED
 USE COPPER CONDUCTORS ONLY

CAUTION:

MORE THAN ONE DISCONNECT MEANS
 MAY BE REQUIRED TO DISCONNECT
 ALL POWER TO THIS UNIT.

LINE VOLTAGE 208/230/60/1
 SEE NAMEPLATE FOR
 MAX. FUSE SIZE
 SEE NOTE ▲

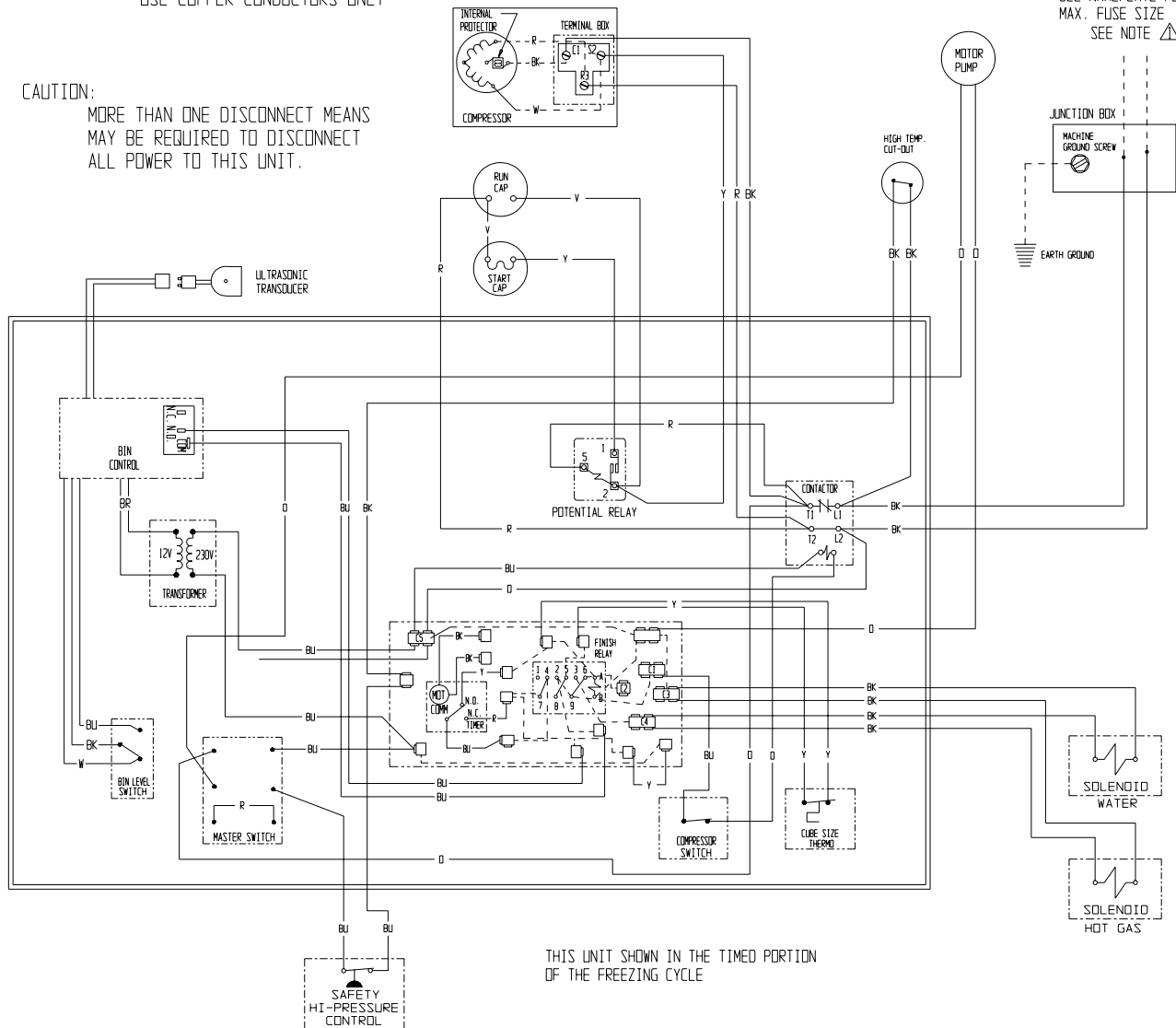

CMS1202 SERVICE PARTS

208-230/60/1 Water Cooled

