

CU1526, CU2026, CU3030 Service Parts

This is the illustrated list of service parts for all models of the CU1526, CU2026 and CU3030 self contained ice machines.

These machines were manufactured in several voltages, which is designated by a numeric voltage code at the end of the model number. The complete model number ends in a series code (alpha), which may also be important for changes during production. Use the complete model number to be sure of obtaining the correct replacement part.

Voltage codes:

- -1 = 115 volts, 60 Hz, single phase
- -6 = 230 volts, 50 Hz, single phase
- -32 = 208-230 volts, 60 Hz, single phase

Table of Contents

CU1526 and CU2026 Cabinet	Page 2
CU1526 and CU2026 Back and Base	Page 3
CU1526, CU2026 Pump, Float Valve, Water Sensor, Purge Valve	Page 4
CU1526 and CU2026 Air Cooled Refrigeration	Page 5
CU1526 and CU2026 Water Cooled Refrigeration.	Page 6
CU1526 and CU2026 Ice Making Area	Page 7
CU1526 and CU2026 Electrical	Page 8
CU3030 Cabinet	Page 9
CU3030 Back and Base	Page 10
CU3030 Pump, Float Valve, Water Sensor, Purge Valve	Page 11
CU3030 Air Cooled Refrigeration	Page 12
CU3030 Water Cooled Refrigeration.	Page 13
CU3030 Ice Making Area.	Page 14
CU3030 Electrical	Page 15

CU1526, CU2026, CU3030 Service Parts

CU1526 and CU2026 Cabinet

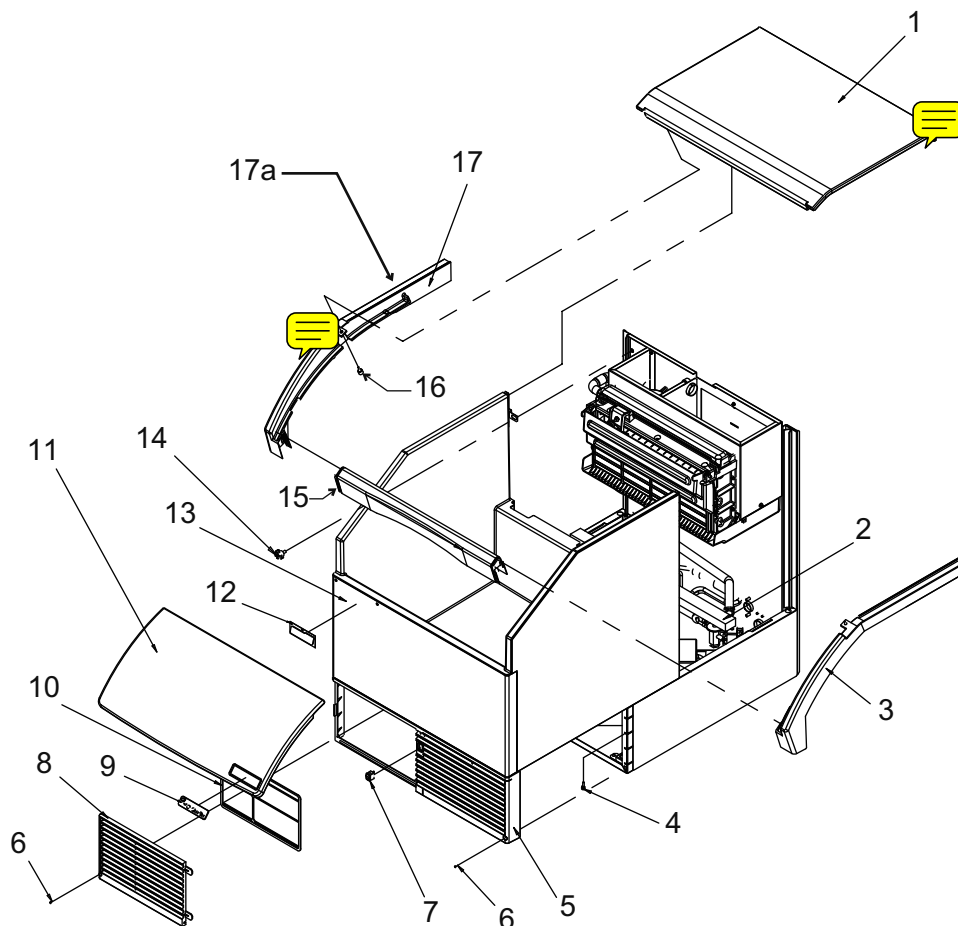

Item Number	Part Number	Description
1	A39132-001	Top panel
2	19-0655-01	Gasket
3	02-4310-04	Right rail, 26" model
4	03-0727-10	Thumb screw
5	02-4304-01	Right grill & frame, 26" model*
6	03-1404-12	Screw
7	12-2991-01	On/Off switch - discontinued
8	02-4304-02	Left grill, 26" model
9	15-0825-01	Emblem
10	02-4308-01	Air filter (AC only)
11	02-4306-20	Door, 26" model
12	15-0824-01	Prodigy logo
13	A39120-021	Bin assembly, includes items 3, 12, 15, 17
14	03-1675-02	3 prong head screw
15	02-4312-01	Frame front, 26" model
16	03-3892-01	Screw, bin to top
17	02-4310-03	Left rail, 26" model
17a	03-1419-17	Flat head screw for rail

Not Shown

NS1	02-3253-01	Scoop
NS1	KLP7	Legs - set of 4
NS3	16-1150-01	Fitting, water 50 Hz
NS4	03-3901-01	Washer, 50 Hz

Note: Frame rail attachment to bin wall changed late 2008 from adhesive only to screws and adhesive. Screw used is #6 x 5/8 flat head. When replacing frame rail on prior bin, use 1/8" dia drill bit to create mounting holes in top of bin wall.

* Part changed CU1526SA-1A serial number 12021320013140, started 2-22-2012, no spot for on-off switch. If replacing grill on unit with switch, mount switch to notch in access valve bracket.

CU1526, CU2026, CU3030 Service Parts

CU1526 and CU2026 Back and Base

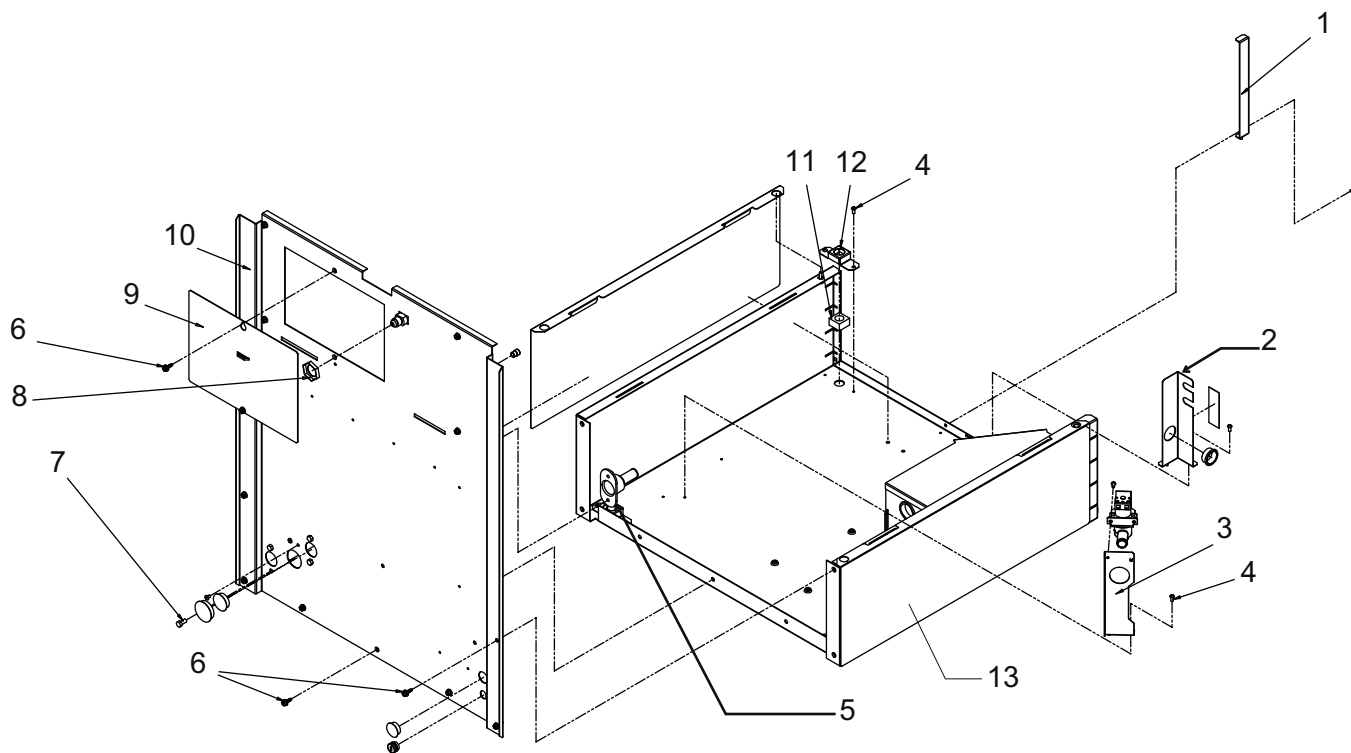

Item Number	Part Number	Description
1	A39145-001	Baffle, AC
2	A39086-001	Bracket, access valves
3	A39092-001	Bracket, purge valve
4	03-1531-01	Screw
5	02-3692-21	Drain fitting
6	03-3868-01	Screw
7	03-0571-00	Screw
8	03-1394-01	Pal nut
9	A39142-001	Service panel
10	A40252-001	Back panel
11	03-1674-01	Nut, leg mounting
12	A39083-001	Bracket, nut
13	A39089-001	Overlay panel, attach with adhesive tape, item 13a, 2 feet
13a	19-0642-02	Adhesive tape, order by foot.

CU1526, CU2026, CU3030 Service Parts

CU1526, CU2026 Pump, Float Valve, Water Sensor, Purge Valve

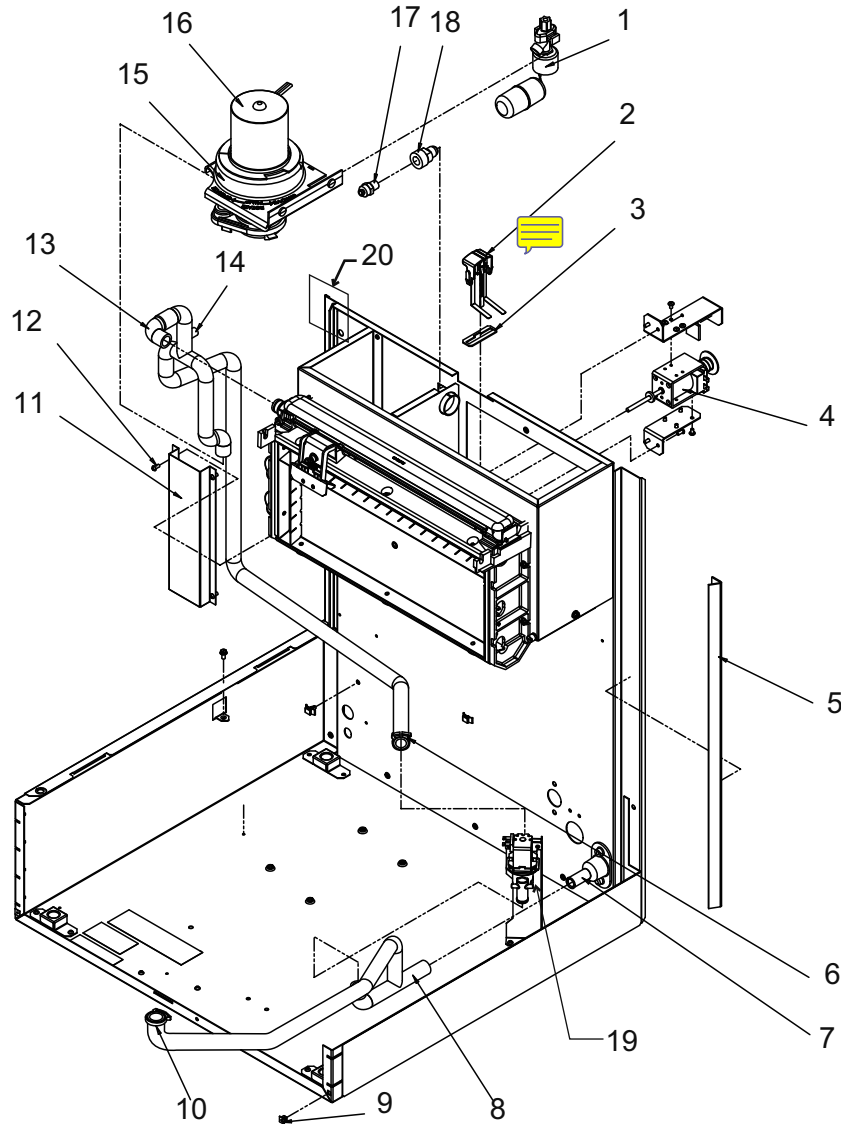

Item Number	Part Number	Description
1	02-3612-01	Float valve, with shut off
	02-4652-01	Float valve, no shut off
1a	13-0895-01	Inlet tubing, order 2, cut to 15"
2	A39126-021	Water level sensor
3	A39143-001	Spacer
4	12-3060-21	Harvest assist solenoid, 115 v
	12-3060-22	Harvest assist solenoid, 230 v Includes mounting brackets
5	02-4491-01	Gasket, corner
6	02-2814-09	Hose clamp
7	02-3692-21	Drain fitting
8	A39144-001	Drain hose, 26" model
9	03-3804-01	Screw receptacle
10	02-2814-10	Hose clamp
11	A39151-001	Chase cover
12	03-1531-01	Screw
13	02-4299-01	Pump hose, 26" model
14	11-0515-21	Temp sensor set
15	02-4318-01	Pump bracket
16	12-2919-21	Water pump, 115 volt models
	12-2919-22	Water pump, 230 volt models
17	16-1039-01	Male connector
18	16-0835-01	Water inlet fitting, 3/8 flare
19	11-0564-01	Purge valve, 115 volt models
	11-0564-02	Purge valve, 230 volt models
20	13-0954-01	Foam pad, 2" x 2"

CU1526, CU2026, CU3030 Service Parts

CU1526 and CU2026 Air Cooled Refrigeration

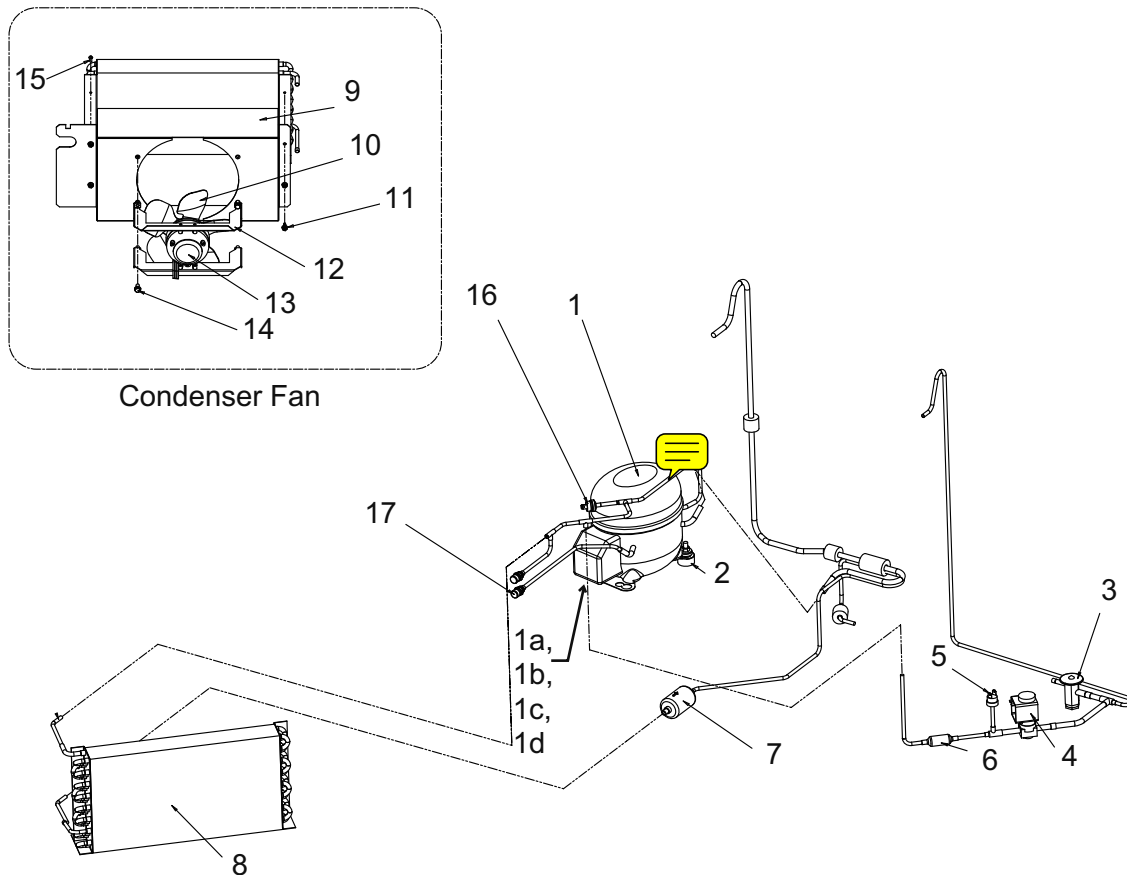

Item Number	Part Number	Description	Part Number	Description
1	18-8932-21	Compressors*	12-2733-30	HGV rebuild kit
1a	18-8932-31	Overload for above	5	11-0566-21 Fan control pressure switch
1b	18-8932-26	CU1526 230/50	6	16-1063-02 Strainer -discontinued 2011
1c	18-8933-31	Overload for above	7	02-3319-01 Dryer
1d	18-8933-22	CU2026, 208-230/60	8	18-8942-01 Condenser
2	03-1406-10	Hex nut	9	A39084-001 Shroud
	03-3900-01	Screw (up thru base)	10	18-8773-01 Fan blade
	18-0108-41	Sleeve	11	03-3868-01 Screw
	18-4700-28	Grommet	12	A39113-001 Bracket, motor
	03-1407-07	Washer	13	Fan motors
3	16-1183-02	TXV - Danfoss	12-2989-01	CU1526, 115/60
	19-0599-01	Insulation for TXV	12-2989-02	CU1526, 230/50
4	11-0493-04	Hot gas valve, 115/60	12-1681-23	CU2026, 115/60
	12-2719-21	Coil only, 115 volt	12-1681-04	CU2026, 208-230/60-50
	11-0493-05	Hot gas valve, 230/60-50	14	03-1645-01 Screw
	12-2719-22	Coil only, 230 volt	15	03-1531-01 Screw
			16	11-0501-05 Hi pressure cut out
			17	16-1140-01 Port cap
				16-1139-01 Core
				16-1138-01 Seat

* Compressors include overload, run capacitor, PTCR and dryer

CU1526, CU2026, CU3030 Service Parts

CU1526 and CU2026 Water Cooled Refrigeration

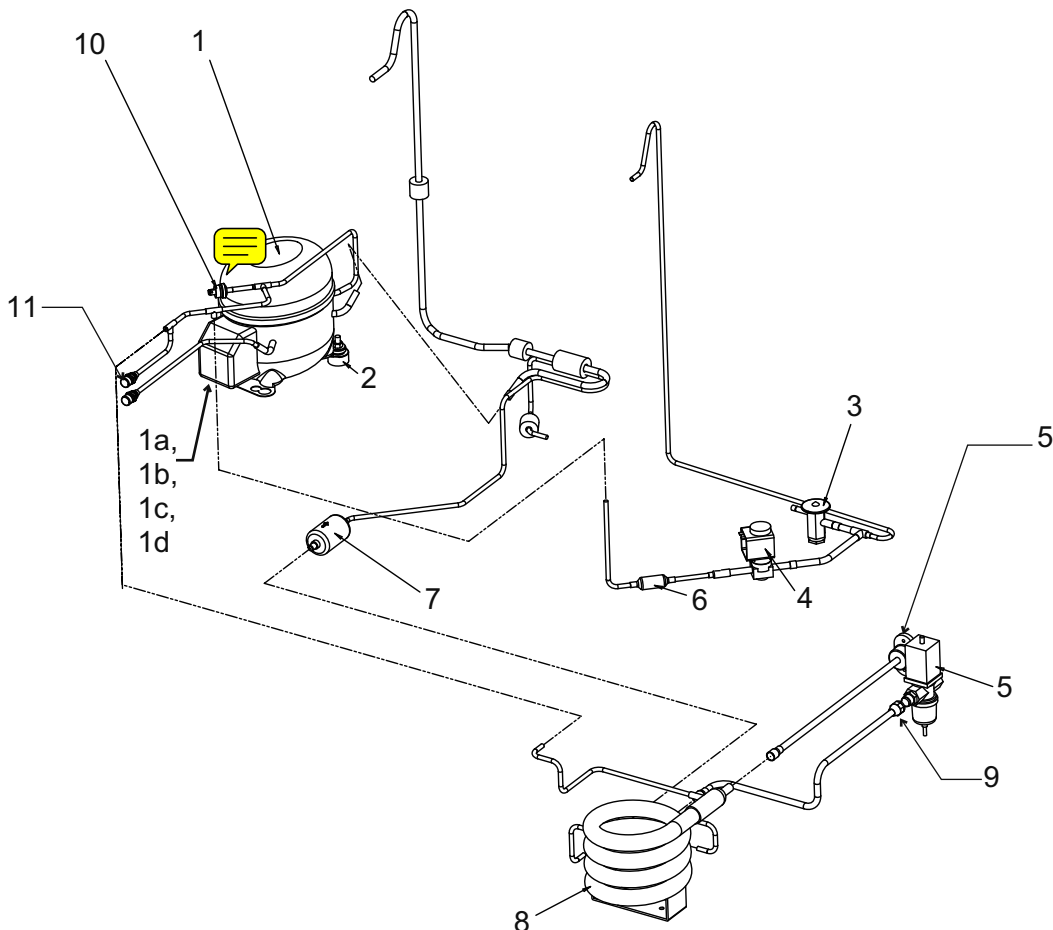

Item Number	Part Number	Description
1		Compressors*
	18-8932-21	CU1526 115/60
1a	18-8932-31	Overload for above
	18-8932-26	CU1526 230/50
1b	18-8932-32	Overload for above
	18-8933-21	CU2026 115/60
1c	18-8933-31	Overload for above
	18-8933-22	CU2026, 208-230/60
	18-8933-26	CU2026, 208-230/50
1d	18-8933-32	Overload for above
2		Compressor mounting hardware
	03-1406-10	Hex nut
	03-3900-01	Screw (up thru base)
	18-0108-41	Sleeve
	18-4700-28	Grommet
	03-1407-07	Washer
3	16-1183-02	TXV - Danfoss
	19-0599-06	Insulation for TXV
4	11-0493-04	Hot gas valve, 115/60
	12-2719-01	Coil only, 115 volt
	11-0493-05	Hot gas valve, 230/60-50
	12-2719-02	Coil only, 230 volt
	12-2733-30	HGV rebuild kit
5	11-0608-21	Water regulating valve
6	16-1063-02	Strainer - discontinued 2011
7	02-3319-01	Dryer
8	18-8869-01	Condenser
9	16-0355-00	Coupling half
10	11-0501-01	Hi pressure cut out - WC
11	16-1140-01	Port cap
	16-1139-01	Core
	16-1138-01	Seat

* Compressors include overload, run capacitor, PTCR and dryer.

CU1526, CU2026, CU3030 Service Parts

CU1526 and CU2026 Ice Making Area

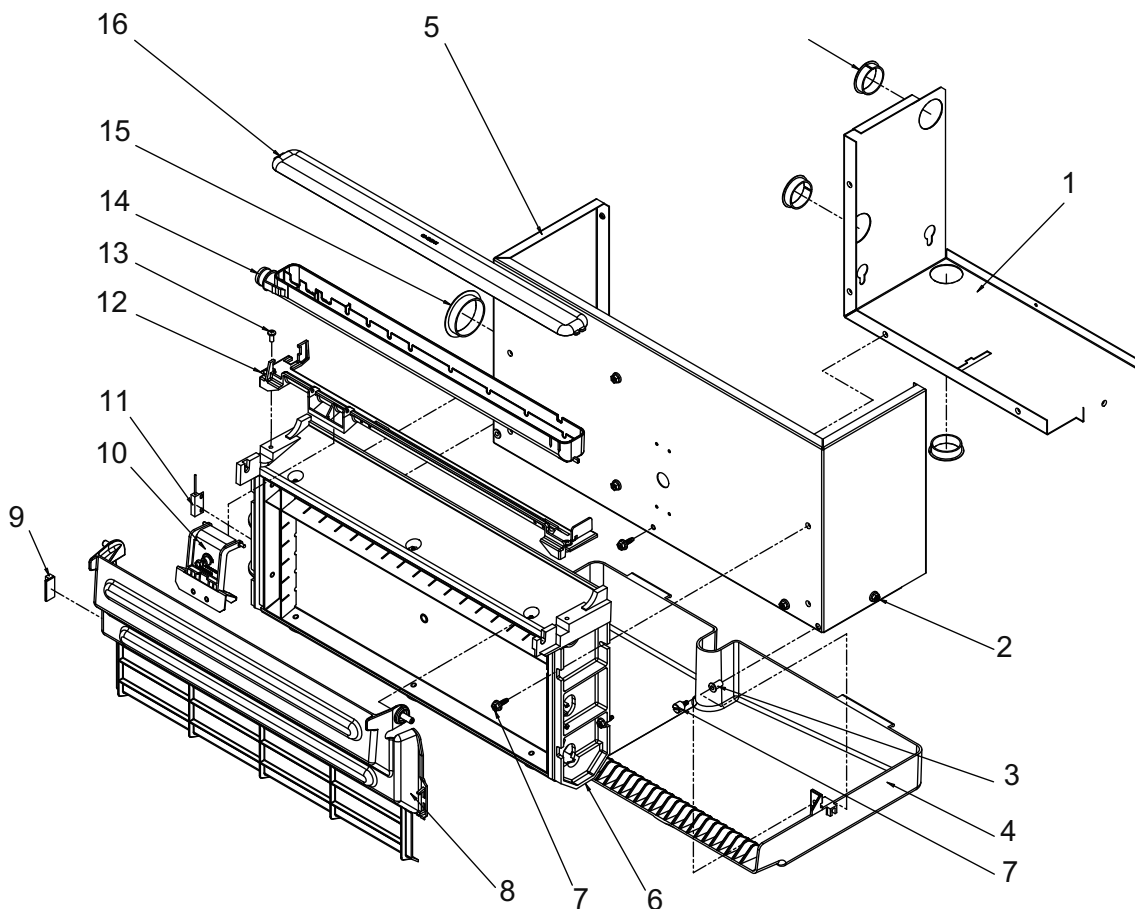

Item Number	Part Number	Description
1	A39090-001	Support
2	03-3868-01	Screw
3	03-1692-01	Insert
4	02-4315-01	Reservoir
5	A39091-001	Evaporator mounting bracket
6	A38626-021	Evaporator, small cube
	A38626-022	Evaporator, med cube
7	03-3868-01	Screw
8	02-4307-01	Curtain - no mag
9	11-0563-05	Magnet
10	A39031-021	Ice thickness sensor
11	11-0563-04	Curtain switch
12	02-4205-01	Mounting bracket
13	03-1403-15	Screw
14	02-4064-01	Water distributor
15	12-1213-15	Snap bushing
16	02-4065-01	Water distributor cover

CU1526, CU2026, CU3030 Service Parts

CU1526 and CU2026 Electrical

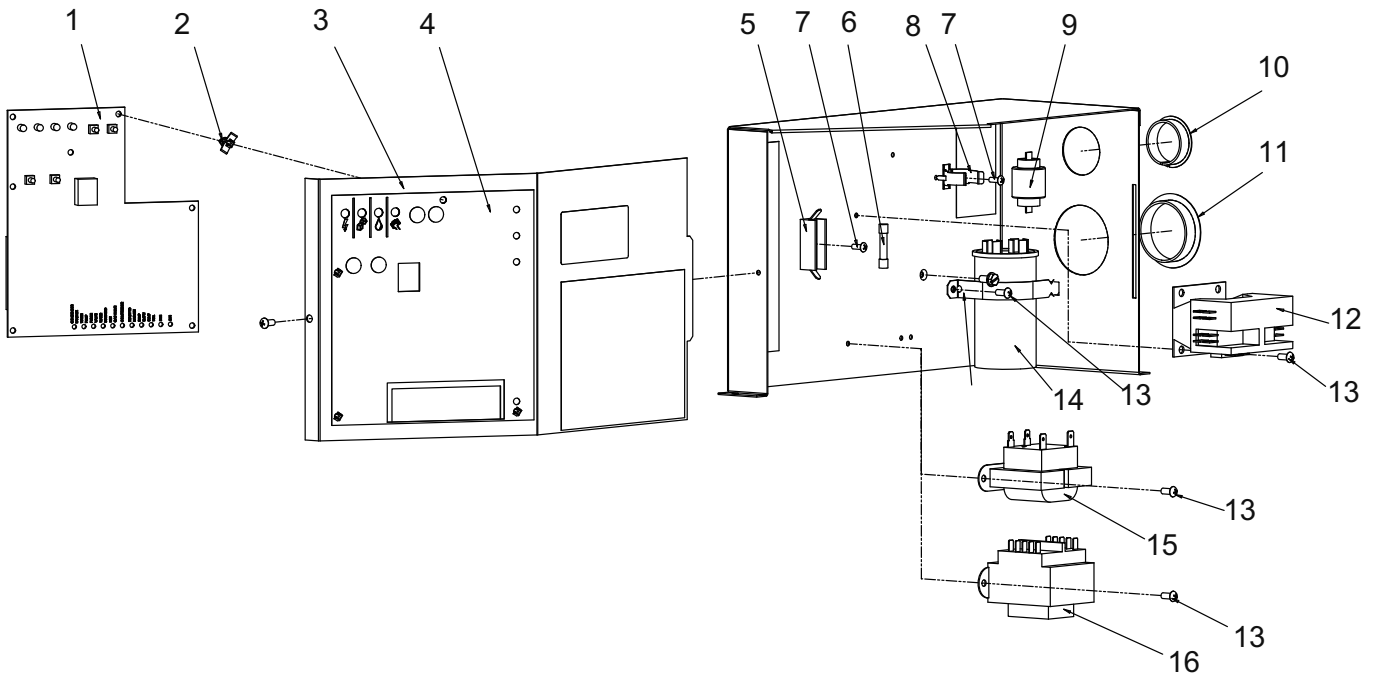

Item Number	Part Number	Description
1	11-0621-21	Controller
2	03-1727-02	Stand off
3	A39081-001	Control box cover
4	02-4302-01	Overlay
5	12-2687-01	Fuse block, 50 Hz only
6	12-2686-01	Fuse, 50 Hz only
7	03-1638-06	Screw
8	18-8835-02	Bracket, PTCR
9	18-8835-01	PTCR
10	12-1213-13	Snap bushing
11	12-1213-15	Snap bushing
12	12-2469-03	Contactor, 115/60
	12-2469-02	Contactor, 230/60-50
13	03-1531-01	Screw
14	18-1902-68	Run capacitor, for all but CU2026-6
	18-8878-01	Run capacitor, CU2026 50 Hz
15	12-2924-01	Transformer, 115 to 12
	12-2924-02	Transformer, 60 Hz, 230 to 12
16	12-2639-01	Transformer, 50 Hz, 230 to 12

Not Shown		
NS1	12-2959-01	High voltage harness - 60 Hz
NS2	12-2988-01	High voltage harness - 50 Hz
NS3	12-2931-01	Control power harness - 60 Hz
NS4	12-2944-01	Control power harness - 50 Hz
NS5	12-1638-14	Power cord, 115/60
NS6	12-1638-18	Power cord, 208-230/60
NS7	12-1638-22	Power cord, 230/50
NS8	12-3020-01	Harness, On/Off switch to connector*
NS8A	12-3020-02	Harness, item NS8 to transformer*
NS9	12-2936-01	Fan motor harness
NS10	12-2930-01	Harness, contactor to compressor

* Early switch harness was one piece, changed Sept 08 to include a connector. Order both NS8 and NS8A to replace early harness. NS8 and NS8A not used after on off switch disconnected.



CU1526, CU2026, CU3030 Service Parts

CU3030 Cabinet

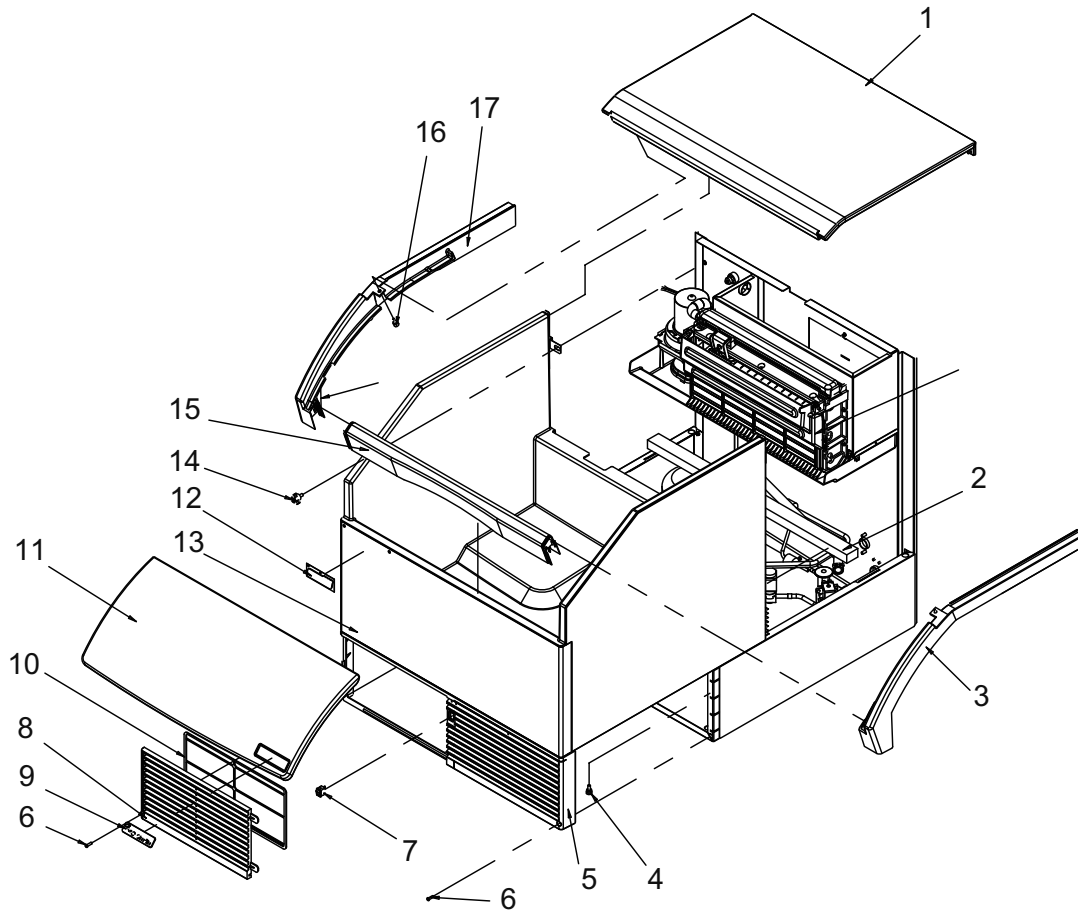

Item Number	Part Number	Description
1	A39133-001	Top panel
2	19-0655-01	Gasket, AC only
3	02-4310-02	Right rail, 30" model
4	03-0727-10	Thumb screw
5	02-4303-01	Right grill/frame, 30" model*
6	03-1404-12	Screw
7	12-2991-01	On/Off switch
8	02-4303-02	Left grill/insert, 30" model
9	15-0825-01	Emblem
10	02-4308-02	Filter, front, 30" model
11	02-4314-20	Door
12	15-0824-01	Prodigy emblem
13	A39121-021	Bin assembly, includes items 3, 12, 15, 17
14	03-1675-02	3 prong head screw
15	02-4312-02	Frame front
16	03-3892-01	Screw, bin to top
17	02-4310-01	Left rail, 30" model
	03-1419-17	Screw, rail attachment

Not Shown		
NS1	02-3253-01	Scoop
NS2	KLP7	Legs - set of 4
NS3	16-1150-01	Fitting, 50 Hz models
NS4	03-3901-01	Washer, 50 Hz models

Note: Frame rail attachment to bin wall changed late 2008 from adhesive only to screws and adhesive. Screw used is #6 x 5/8 flat head. When replacing frame rail on prior bin, use 1/8" dia drill bit to create mounting holes in top of bin wall.

* Part changed 2012, no spot for on-off switch. If replacing grill on unit with switch, mount switch to notch in access valve bracket.

CU1526, CU2026, CU3030 Service Parts

CU3030 Back and Base

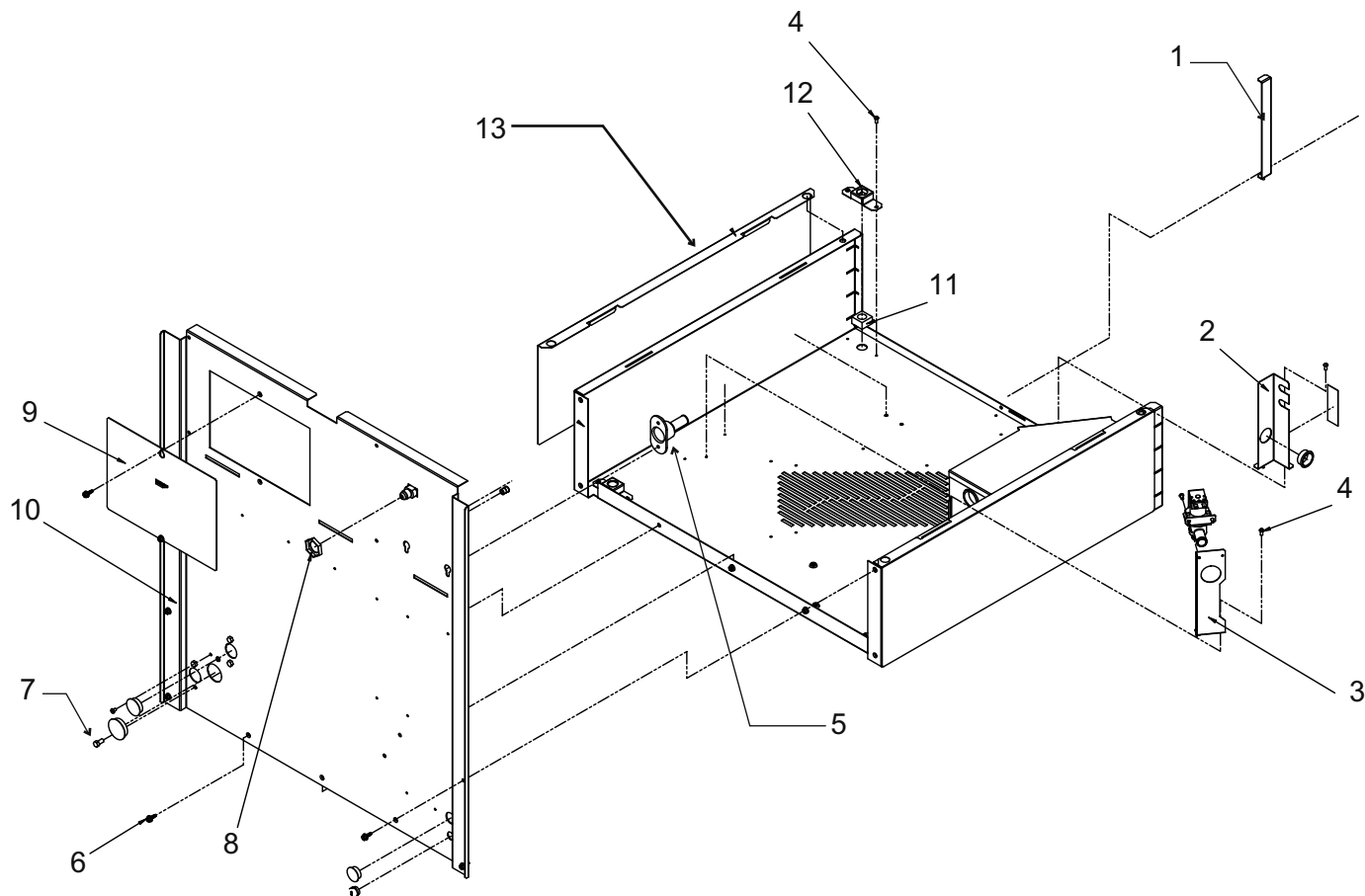

Item Number	Part Number	Description
1	A39145-001	Baffle, AC
2	A39086-001	Bracket, access valves
3	A39092-001	Bracket, purge valve
4	03-1531-01	Screw
5	02-3692-21	Drain fitting
6	03-3868-01	Screw
7	03-0571-00	Screw
8	03-1394-01	Pal nut
9	A39142-001	Service panel
10	A40253-001	Back panel, 30" model
11	03-1674-01	Nut, leg mounting
12	A39083-001	Bracket, nut
13	A39096-001	Overlay panel, attach with adhesive tape, item 13a 2 feet.
13a	19-0642-02	Adhesive tape, order by foot

CU1526, CU2026, CU3030 Service Parts

CU3030 Pump, Float Valve, Water Sensor, Purge Valve

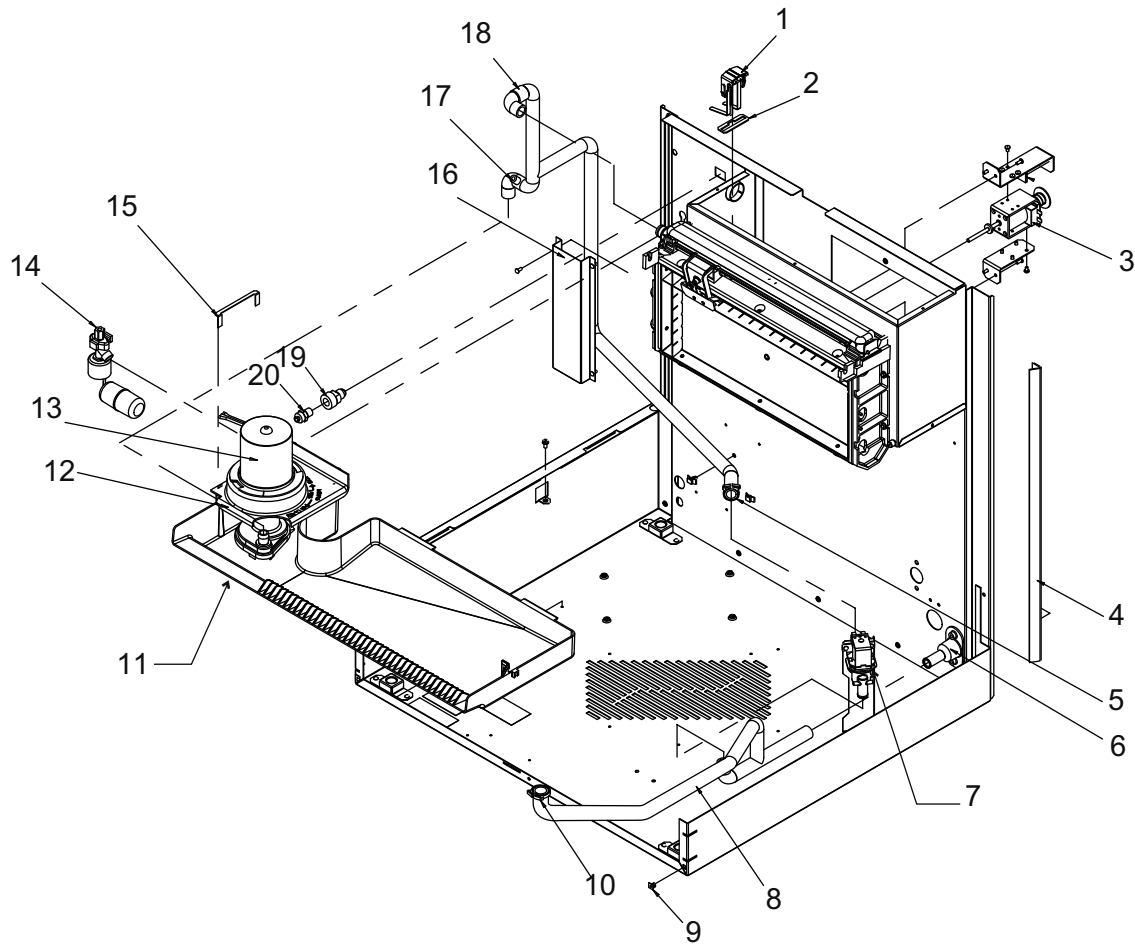

Item Number	Part Number	Description
1	A39126-021	Water level sensor
2	A39143-001	Spacer
3	12-3035-21	Harvest assist solenoid, 115v
	12-3035-22	Harvest assist solenoid, 230 v
		Includes mounting brackets
4	02-4491-01	Corner gasket
5	02-2814-09	Hose clamp
6	02-3692-21	Drain fitting
7	11-0564-01	Purge valve, 115 volt models
	11-0564-02	Purge valve, 230 volt models
8	02-4301-01	Drain hose, 30" models
9	03-3804-01	Screw receptacle
10	02-2814-10	Hose clamp
11	02-4316-01	Reservoir, 30" models
12	02-4318-01	Pump bracket
13	12-2919-21	Water pump, 115 volt models
	12-2919-22	Water pump, 230 volt models
14	02-3612-01	Float valve, with shut off
	02-4652-01	Float valve, no shut off
15	A39152-001	Snap alignment clip
16	A39151-001	Chase cover
17	11-0515-21	Temp sensor set
18	02-4300-01	Pump hose
19	16-0835-01	Water inlet fitting, 3/8 flare
20	16-1039-01	Male connector

CU1526, CU2026, CU3030 Service Parts

CU3030 Air Cooled Refrigeration

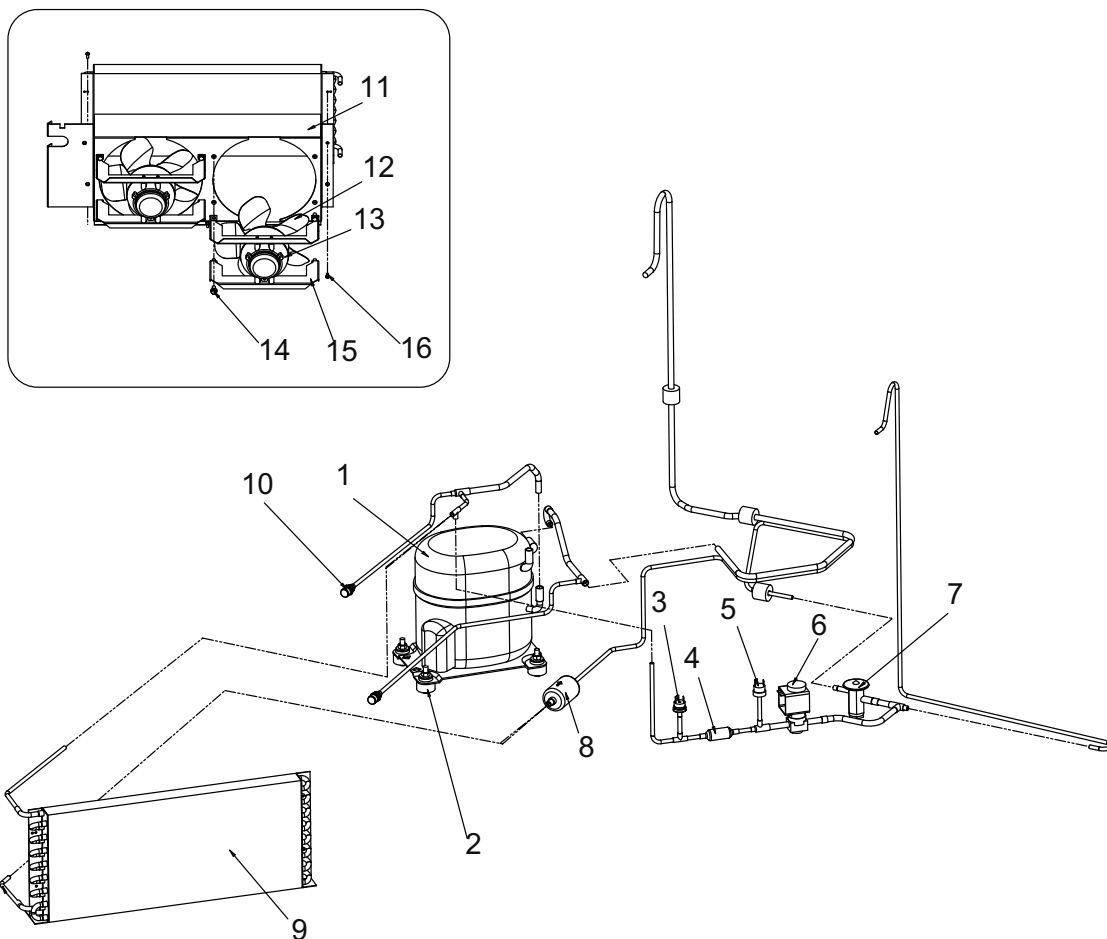

Item Number	Part Number	Description	Item Number	Part Number	Description
1		Compressors*	7	16-1183-02	TXV - Danfoss
1a	18-8897-21	CU3030 comp. 115/60		19-0599-06	Insulation for TXV
	18-8897-23	Overload for above	8	02-3319-01	Dryer
	18-8897-22	CU3030 comp. 208-230/60	9	18-8934-01	Condenser
1a	18-8897-27	Overload for above	10	16-1140-01	Port cap
	18-8897-26	CU3030 comp. 230/50		16-1139-01	Core
1a	18-8897-28	Overload for above		16-1138-01	Seat
2		Compressor mounting hardware	11	A39095-001	Fan shroud
	03-1406-10	Hex nut	12	18-8773-01	Fan blade
	03-3900-01	Screw (up thru base)	13	12-1681-23	Fan motor, 115/60
	18-0108-41	Sleeve		12-1681-04	Fan motor, 208-230/60-50
	18-4700-28	Grommet	14	03-1645-01	Screw
	03-1407-07	Washer	15	A39113-001	Bracket, motor
3	11-0501-05	Hi pressure cut out	16	03-1531-01	Screw
4	16-1063-02	Strainer - discontinued 2011			
5	11-0566-21	Fan control pressure switch			
6	11-0493-02	Hot gas valve, 115/60			
	12-2719-21	Coil only, 115/60			
	11-0493-01	Hot gas valve, 230/60-50			

* Compressors include run capacitor, PTCR and dryer.

CU1526, CU2026, CU3030 Service Parts

CU3030 Water Cooled Refrigeration

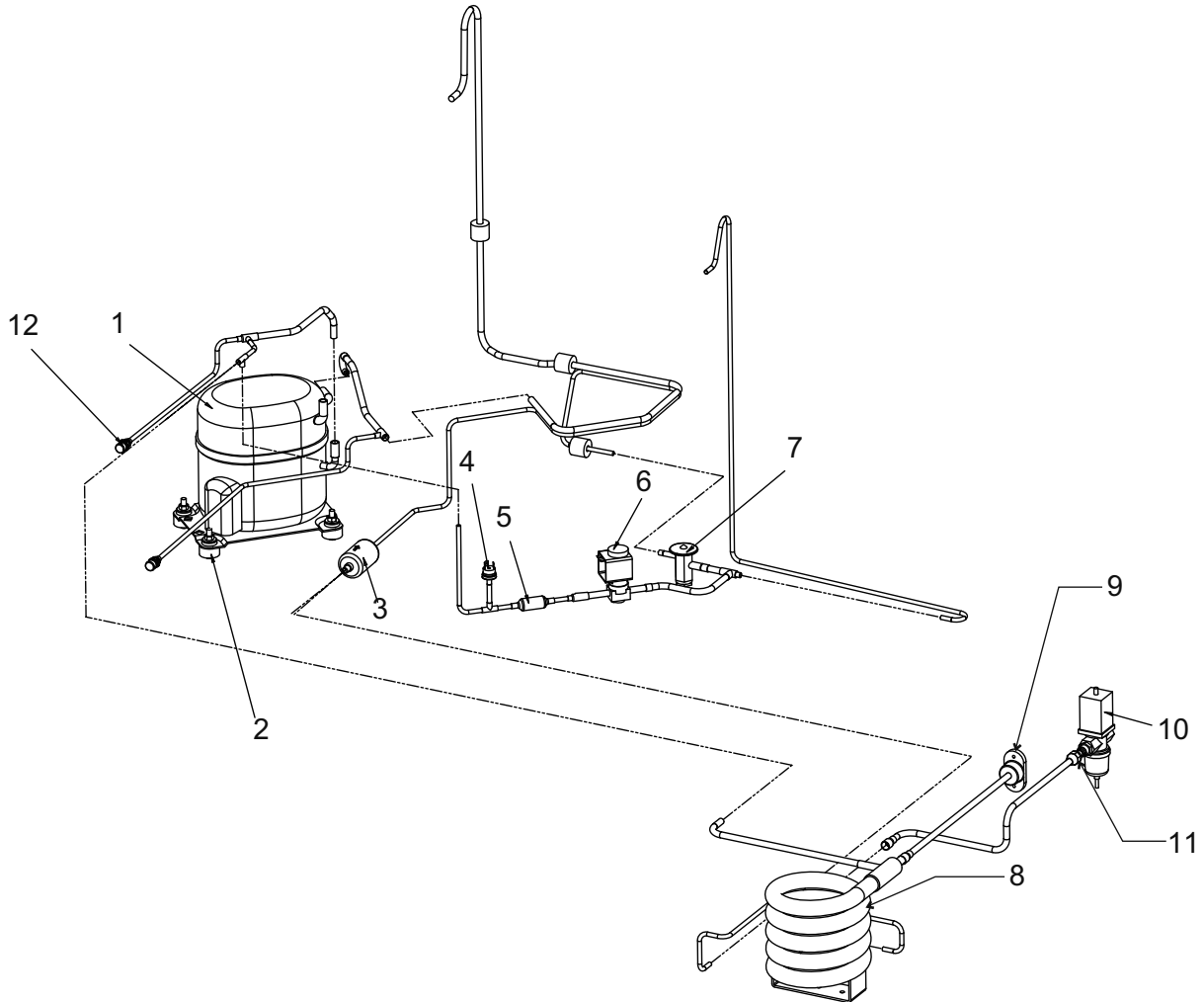

Item Number	Part Number	Description
1		Compressors*
	18-8897-21	CU3030 comp. 115/60
1a	18-8897-23	Overload for above
	18-8897-22	CU3030 comp. 208-230/60
1a	18-8897-27	Overload for above
	18-8897-26	CU3030 comp. 230/50
1a	18-8897-28	Overload for above
2		Compressor mounting hardware
	03-1406-10	Hex nut
	03-3900-01	Screw (up thru base)
	18-0108-41	Sleeve
	18-4700-28	Grommet
	03-1407-07	Washer
3	02-3319-01	Dryer
4	11-0501-01	Hi pressure cut out
5	16-1063-02	Strainer - Discontinued 2011
6	11-0493-02	Hot gas valve, 115/60
	12-2719-21	Coil only, 115/60
	11-0493-01	Hot gas valve, 230/60-50
	12-2719-22	Coil only, 230/60-50
	12-2733-30	HGV rebuild kit
7	16-1183-02	TXV - Danfoss
	19-0599-06	Insulation for TXV
8	18-8871-01	Water cooled condenser
9	A31828-002	Drain fitting
10	11-0608-21	Water regulating valve
11	16-0355-00	Coupling half
12	16-1140-01	Port cap
	16-1139-01	Core
	16-1138-01	Seat

* Compressors include run capacitor, PTCR and dryer.

CU1526, CU2026, CU3030 Service Parts

CU3030 Ice Making Area

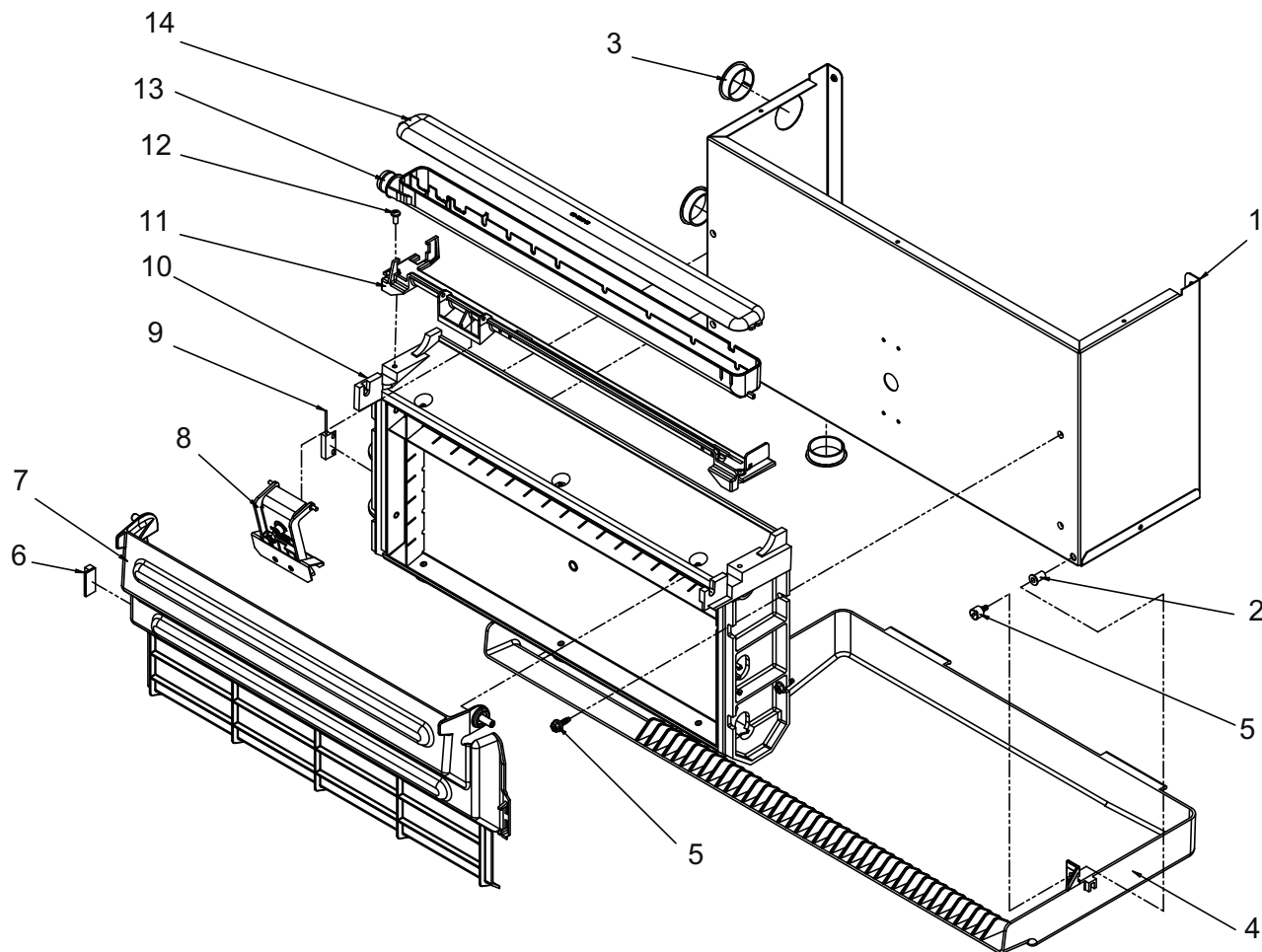

Item Number	Part Number	Description
1	A39094-001	Evaporator mounting bracket
2	03-1692-01	Insert
3	12-1213-13	Snap bushing
4	02-4316-01	Reservoir
5	03-3868-01	Screw
6	11-0563-05	Magnet
7	02-4307-01	Curtain - no mag
8	A39031-001	Ice thickness sensor
9	11-0563-04	Curtain switch
10	A38626-021	Evaporator, small cube
	A38626-022	Evaporator, med cube
11	02-4205-01	Mounting bracket
12	03-1403-15	Screw
13	02-4064-01	Water distributor
14	02-4065-01	Water distributor cover

CU1526, CU2026, CU3030 Service Parts

CU3030 Electrical

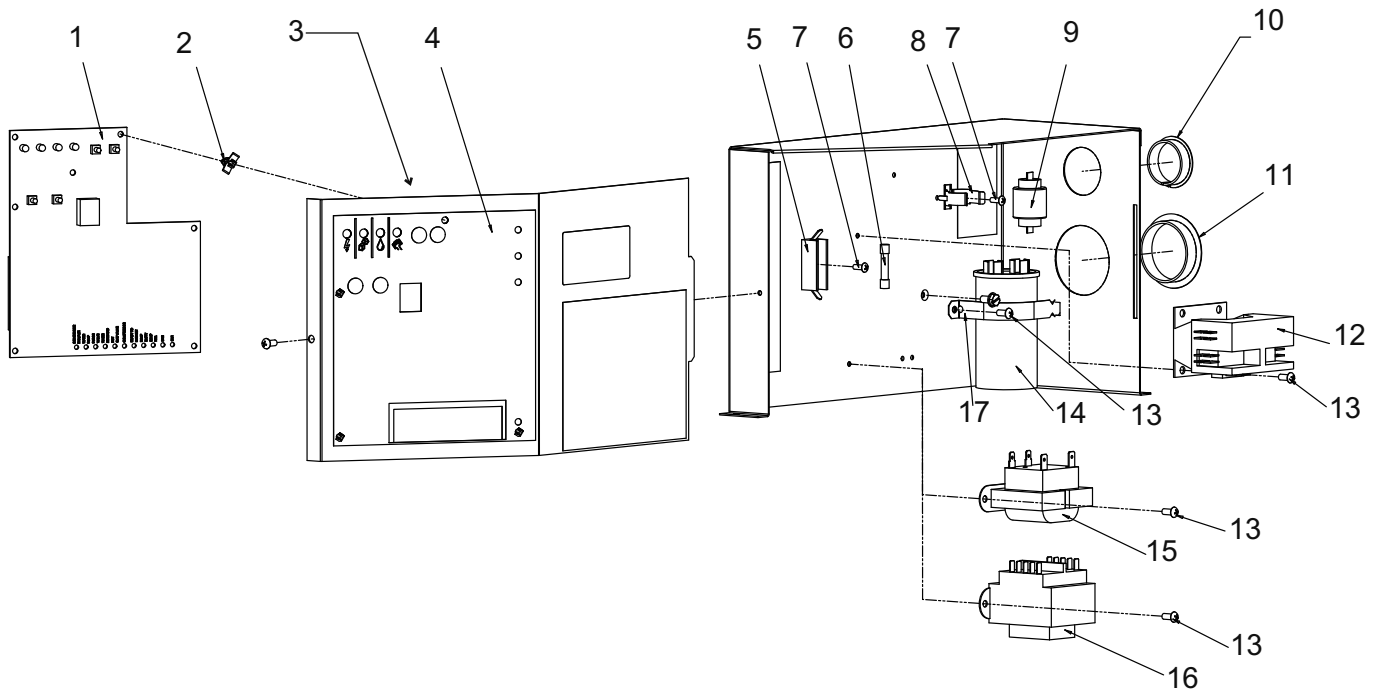

Item Number	Part Number	Description
1	11-0621-21	Controller
2	03-1727-02	Stand off
3	A39081-001	Control box cover
4	02-4302-01	Overlay
5	12-2687-01	Fuse block, 50 Hz only
6	12-2686-01	Fuse, 50 Hz only
7	03-1638-06	Screw
8	18-8835-02	Bracket, PTCR
9	18-8835-01	PTCR
10	12-1213-13	Snap bushing
11	12-1213-15	Snap bushing
12	12-2469-03	Contactator, 115/60
	12-2469-02	Contactator, 230/60-50
13	03-1531-01	Screw
14	18-1902-53	Run capacitor - 115 volt model
	18-1902-68	Run cap - 208-230 volt models
15	12-2924-01	Transformer, 115 to 12
	12-2924-02	Transformer, 60 Hz, 230 to 12
16	12-2639-01	Transformer, 50 Hz, 230 to 12
17	A37651-001	Strap, capacitor

Not Shown

NS1	12-2959-01	High voltage harness - 60 Hz
NS2	12-2988-01	High voltage harness - 50 Hz
NS3	12-2931-01	Control power harness - 60 Hz
NS4	12-2944-01	Control power harness - 50 Hz
NS5	12-1638-14	Power cord, 115/60
NS6	12-1638-18	Power cord, 208-230/60
NS7	12-1638-22	Power cord, 230/50
NS8	12-3020-01	Harness, On/Off switch to connector*
NS8A	12-3020-02	Harness, item NS8 to transformer*
NS9	12-2936-01	Fan motor harness

* Early harness was one piece, changed Sept 08 to include a connector. Order both NS8 and NS8A to replace early harness.