

EH330 and EH430 Service Parts

This part list contains the service parts for the Eclipse 1200, 1400, 1800 and 2000 systems.

The models that are covered include:

- EH330
- EH430
- C1200CP
- C1410CP
- C1800CP
- C2000CP
- ERC1086
- ERC2086

Table of Contents

EH330 Cabinet - <u>A Series</u>	Page 2	EH330 or EH430 Schematic Diagram	Page 18
EH330 Cabinet - <u>B Series</u>	Page 3	EH330 or EH430 Wiring Diagram	Page 19
EH430 Cabinet - <u>A Series</u>	Page 4	CP Single Phase Schematic Diagram	Page 20
EH430 Cabinet - <u>B Series</u>	Page 5	CP Single Phase Wiring Diagram	Page 21
EH330 and EH430 Interior Parts	Page 6	CP Three Phase Wiring Diagram	Page 22
EH330 and EH430 Refrigeration System	Page 7	CP Three Phase Schematic Diagram	Page 23
EH330 Evaporator Compartment	Page 8		
EH430 Evaporator Compartment	Page 9		
EH330 or EH430 Electrical	Page 10		
CP Cabinet	Page 11		
C1200CP Refrigeration System	Page 12		
C1410CP Refrigeration Systems	Page 13		
C1800CP Refrigeration System	Page 14		
C2000CP Refrigeration System	Page 15		
CP Control Box	Page 16		
Remote Condensers	Page 17		

EH330 and EH430 Service Parts

EH330 Cabinet - A Series

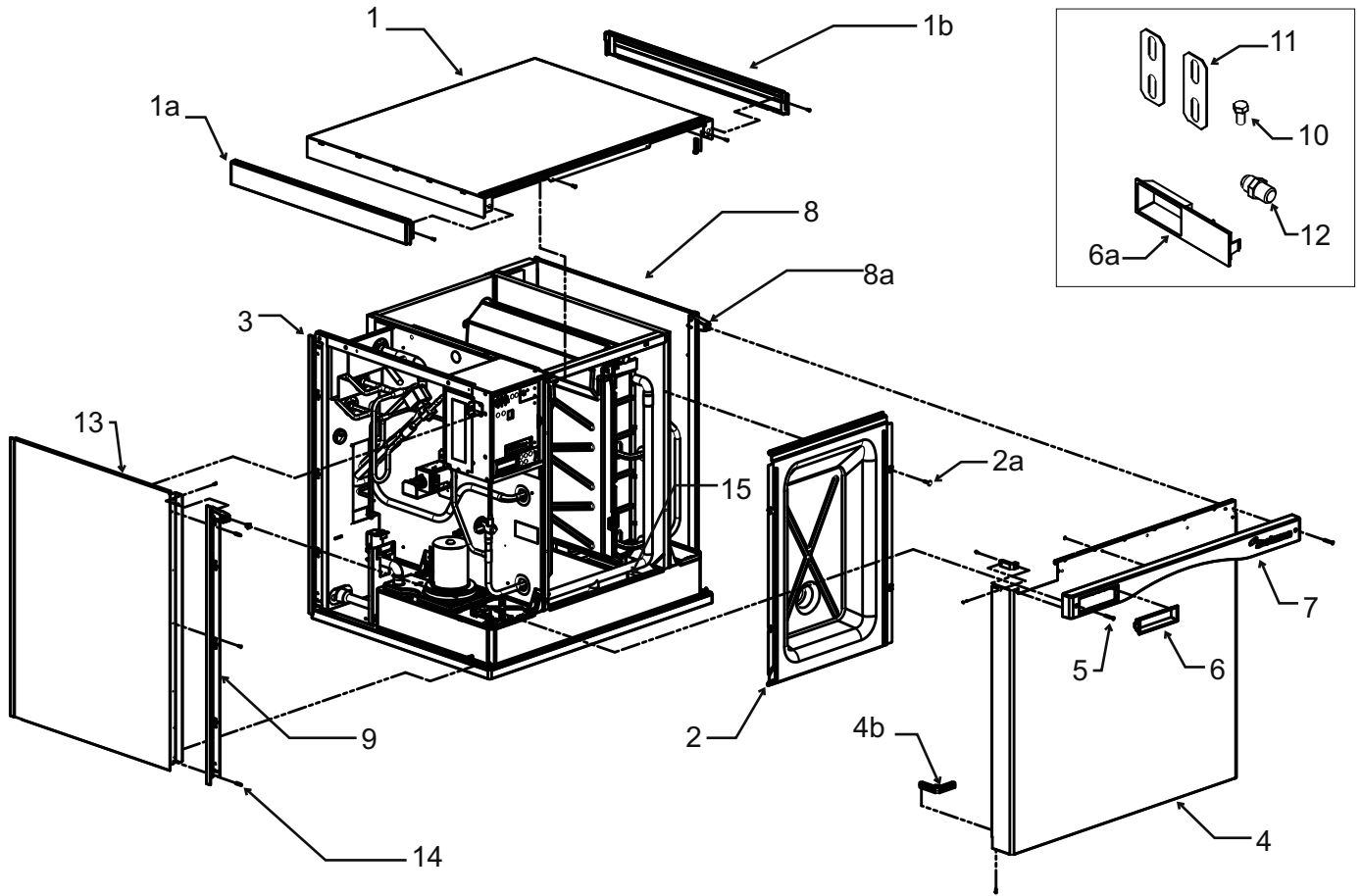

Item Number	Part Number	Description	Item Number	Part Number	Description
1	A38941-022	Top panel, w/trim strips	8a	02-4215-01	Receptacle
1a	02-4221-01	Left trim strip	9	02-4067-01	Side panel support
1b	02-4221-02	Right trim strip	10	03-1405-15	Screw
2	02-4504-01	Evaporator cover	11	A30911-015	Machine straps
2a	03-0727-05	Screw	12	16-0355-00	Inlet water fitting, flare
3	02-4067-03	Side panel support	13	A38551-022	Left side panel
4	A38552-022	Front panel assembly, includes trim strip, gussets and labels.	14	03-1404-12	Screw
4a	02-4216-01	Top gusset	15	13-0943-01	Gasket tape
4b	02-4217-01	Bottom gusset			
5	03-1735-03	Screw, front panel			
6	02-4284-01	Bezel, full window			
6a	02-4284-02	Bezel, partial window			
7	02-4214-02	Trim strip			
8	A38553-021	Right side panel assy			

EH330 and EH430 Service Parts

EH330 Cabinet - B Series

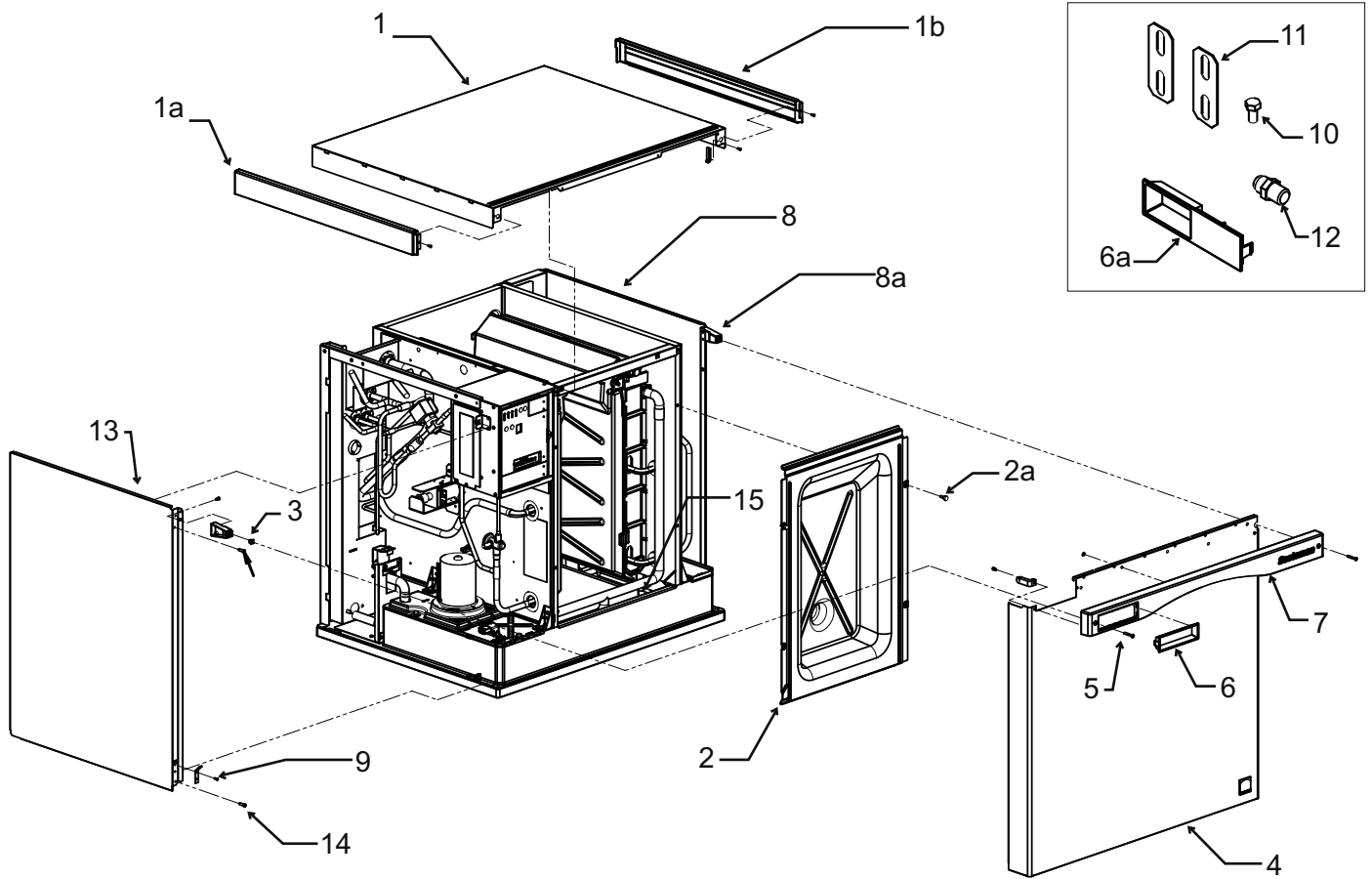

Item Number	Part Number	Description	9	A39571-001	Panel clip
1	A39579-022	Top panel	10	03-1405-15	Screw
1a	02-4221-01	Left trim strip*	11	A30911-015	Machine straps
1b	02-4221-02	Right trim strip*	12	16-0355-00	Inlet water fitting, flare**
2	02-4504-01	Evaporator cover	13	A39580-022	Left side panel
2a	03-0727-05	Screw	14	03-1404-12	Screw
3	03-3804-01	Screw receptacle	15	13-0943-01	Gasket tape
4	A39578-022	Front panel assembly, includes trim strip, gussets and labels.	* Side trim strips discontinued mid 2011.		
4a	02-4216-01	Top gusset	** Bezel and fitting discontinued from production 2/8/2012.		
5	03-1735-03	Screw, front panel			
6	02-4284-01	Bezel, full window			
6a	02-4284-02	Bezel, partial window**			
7	02-4214-02	Trim strip			
8	A39581-021	Right side panel assy			
8a	02-4215-01	Receptacle			

EH330 and EH430 Service Parts

EH430 Cabinet - A Series

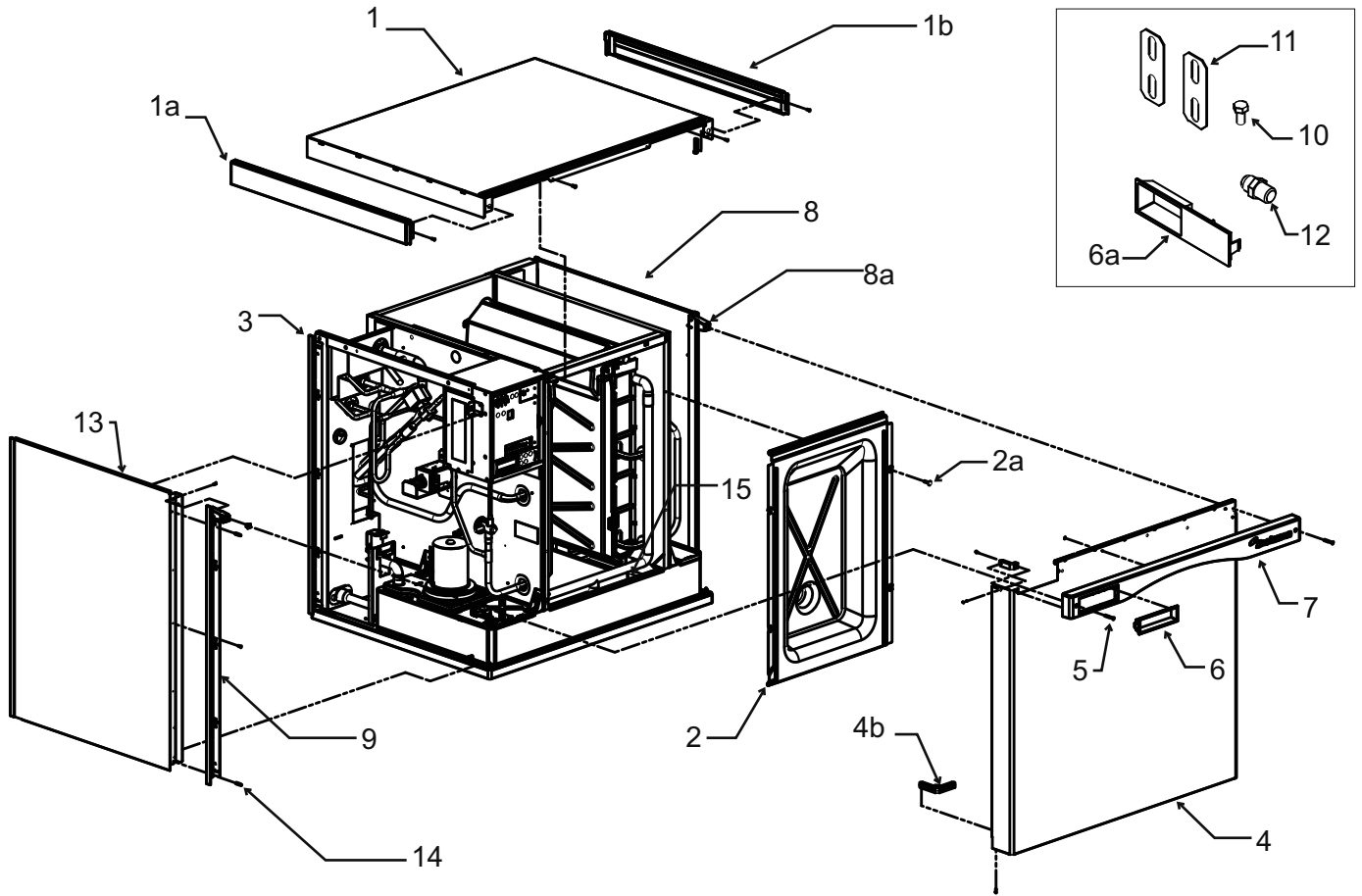

Item Number	Part Number	Description	Part Number	Description
1	A38941-022	Top panel, w/trim strips	8a	02-4215-01 Receptacle
1a	02-4221-01	Left trim strip	9	02-4067-03 Side panel support
1b	02-4221-02	Right trim strip	10	03-1405-15 Screw
2	02-4184-01	Evaporator cover	11	A30911-015 Machine straps
2a	03-0727-05	Screw	12	16-0355-00 Inlet water fitting, flare
3	02-4067-03	Side panel support	13	A38551-024 Left side panel
4	A38552-023	Front panel assembly, includes trim strip, gussets and labels.	14	03-1404-12 Screw
4a	02-4216-01	Top gusset	15	13-0943-01 Gasket tape
4b	02-4217-01	Bottom gusset		
5	03-1735-03	Screw, front panel		
6	02-4284-01	Bezel, full window		
6a	02-4284-02	Bezel, partial window		
7	02-4214-02	Trim strip		
8	A38553-022	Right side panel assy		

EH330 and EH430 Service Parts

EH430 Cabinet - B Series

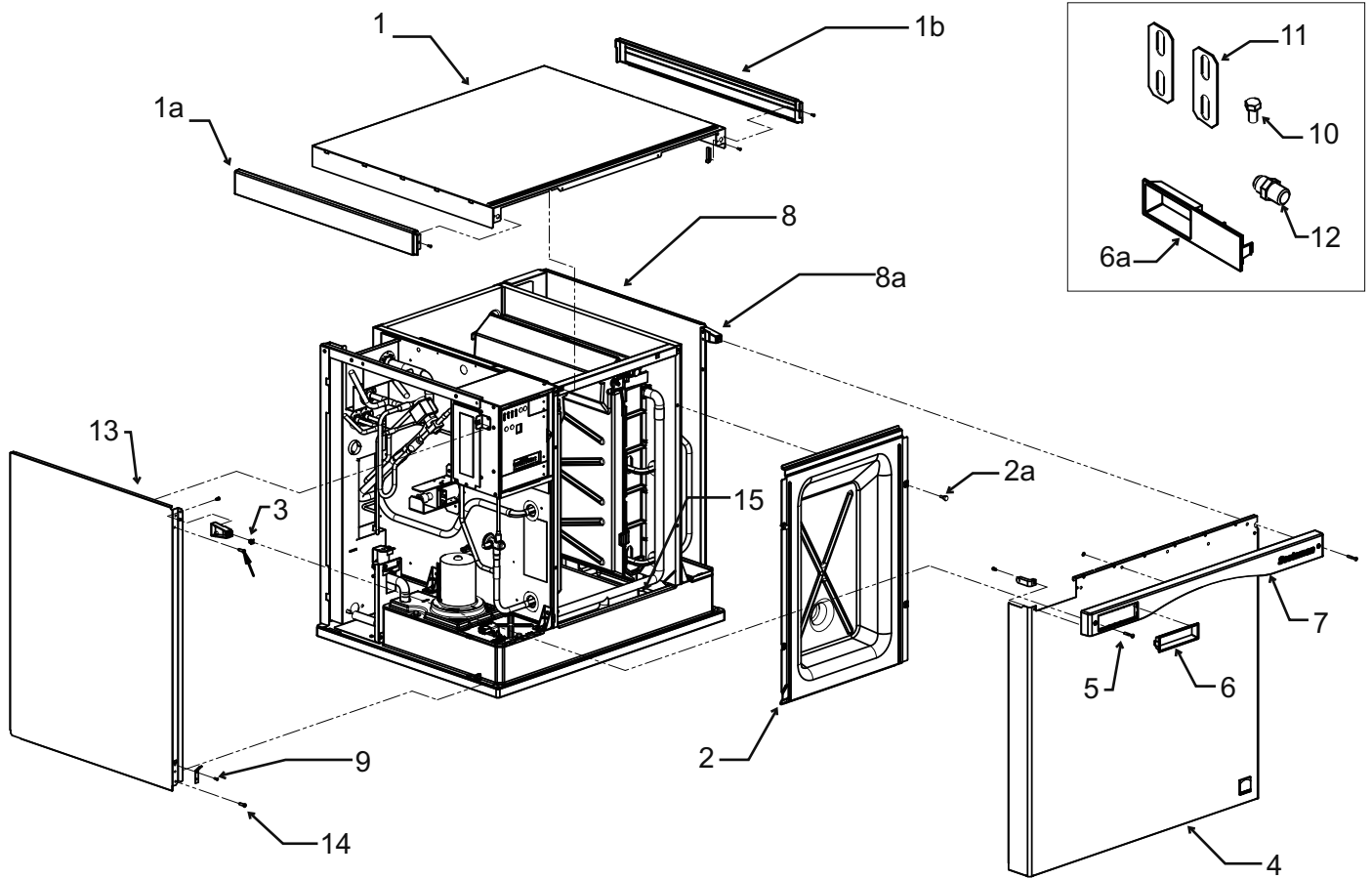

Item Number	Part Number	Description	Item Number	Part Number	Description
1	A39579-022	Top panel, w/trim strips	9	A39571-001	Panel clip
1a	02-4221-01	Left trim strip	10	03-1405-15	Screw
1b	02-4221-02	Right trim strip	11	A30911-015	Machine straps
2	02-4504-01	Evaporator cover	12	16-0355-00	Inlet water fitting, flare
2a	03-0727-05	Screw	13	A39580-024	Left side panel
3	03-3804-01	Screw receptacle	14	03-1404-12	Screw
4	A39578-023	Front panel assembly, includes trim strip, gussets and labels.	15	13-0943-01	Gasket tap
4a	02-4216-01	Top gusset			
5	03-1735-03	Screw, front panel			
6	02-4284-01	Bezel, full window			
6a	02-4284-02	Bezel, partial window			
7	02-4214-02	Trim strip			
8	A39581-022	Right side panel assy			
8a	02-4215-01	Receptacle			

EH330 and EH430 Service Parts

EH330 and EH430 Interior Parts

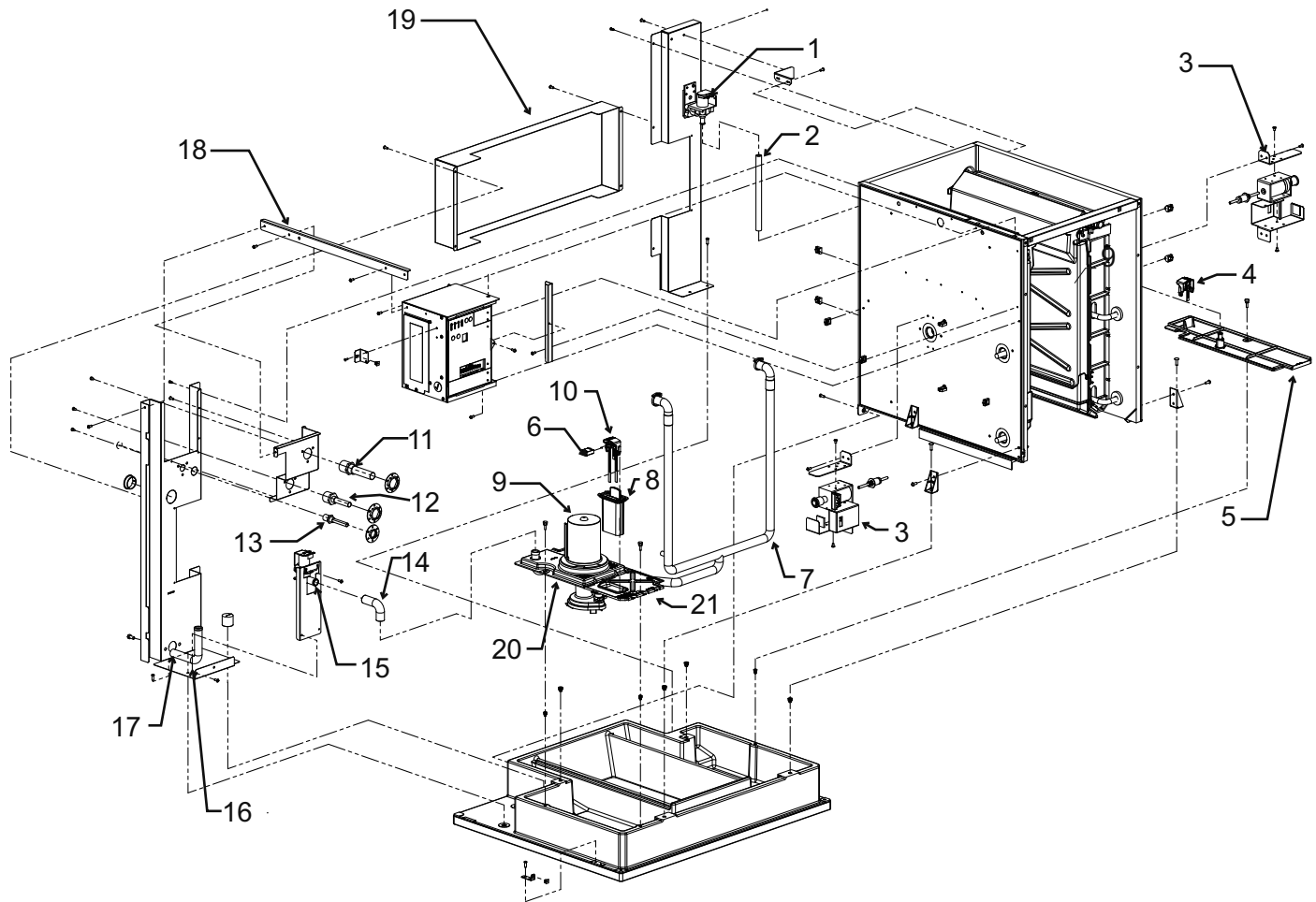

Item Number	Part Number	Description
1	12-2922-01	Inlet water sol valve
2	13-0674-02	Tubing, order 2 (ft)
3	12-3036-21	Harvest assist sol. EH430
	12-3035-21	Harvest assist sol. EH330 includes brackets
4	A39030-022	Level sensor, discontinued
5	02-4175-01	Sump cover, rt
6	12-2928-01	WLS harness, no wire to item 4
7	02-4182-01	Water pump hose, EH430
	02-4505-01	Water pump hose, EH330
8	02-4332-01	WLS cover, prior fits 21
8a	02-4646-01	Probe guard, fits 21a
9	12-2920-21	Water pump
10	A39030-021	Water level sensor
11	16-0850-04	Suction line fitting
12	16-0850-01	Vapor line fitting
13	16-0850-03	Liquid line fitting
14	A38863-001	Tube
15	11-0564-01	Purge valve
16	A38863-002	Tube, out
17	02-3692-21	Drain fitting
18	A38804-001	Brace
19	A38796-001	Chase
20	02-4177-01	Pump bracket
21	02-4178-01	Sump cover, prior, fits 8
21a	02-4649-01	Sump cover, fits 8a

EH330 and EH430 Service Parts

EH330 and EH430 Refrigeration System

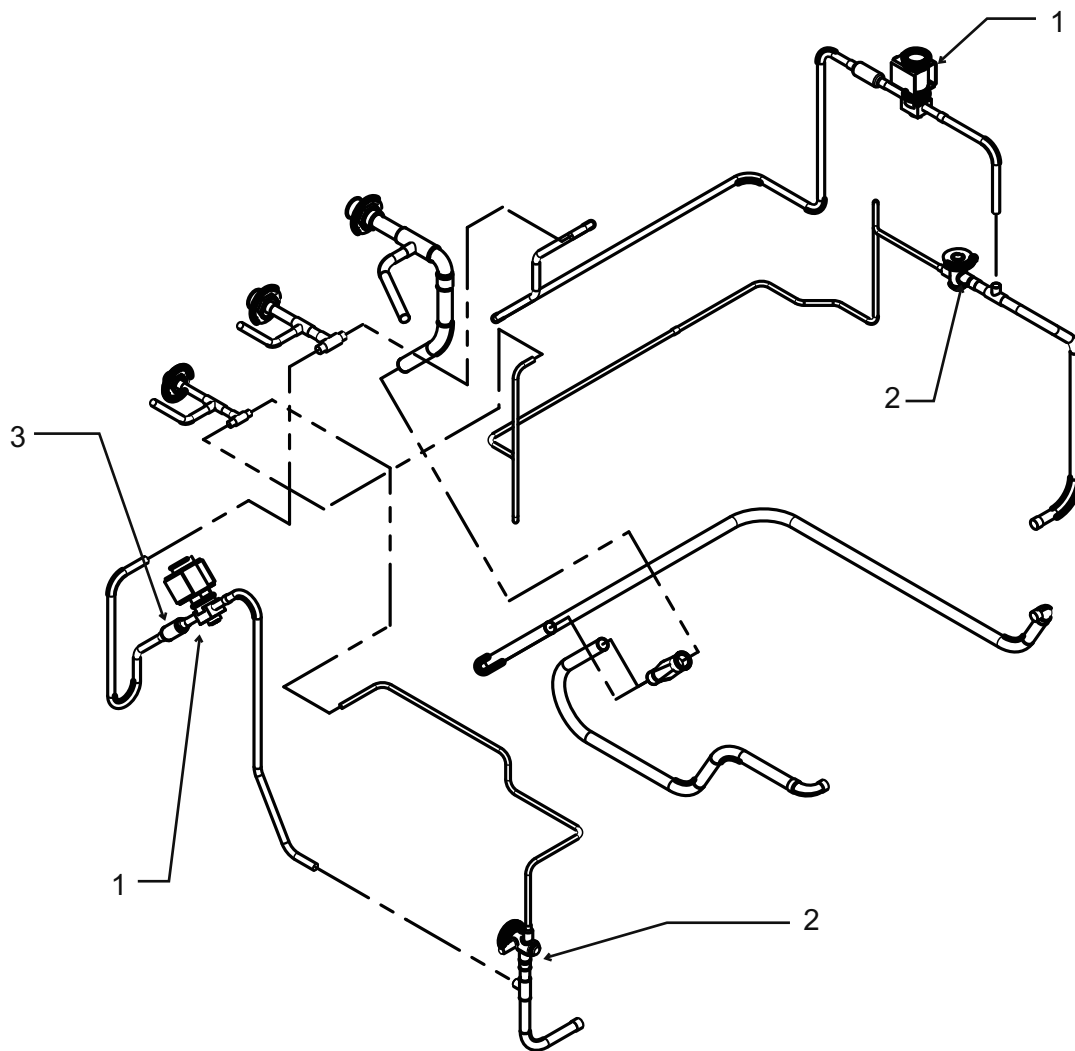

Item Number	Part Number	Description
1	11-0493-03	Vapor valve
2	16-1130-01	TXV - EH430
	16-1142-01	TXV - EH330
	02-4045-01	Insulation for TXV
3	16-1063-01	Strainer

EH330 and EH430 Service Parts

EH330 Evaporator Compartment

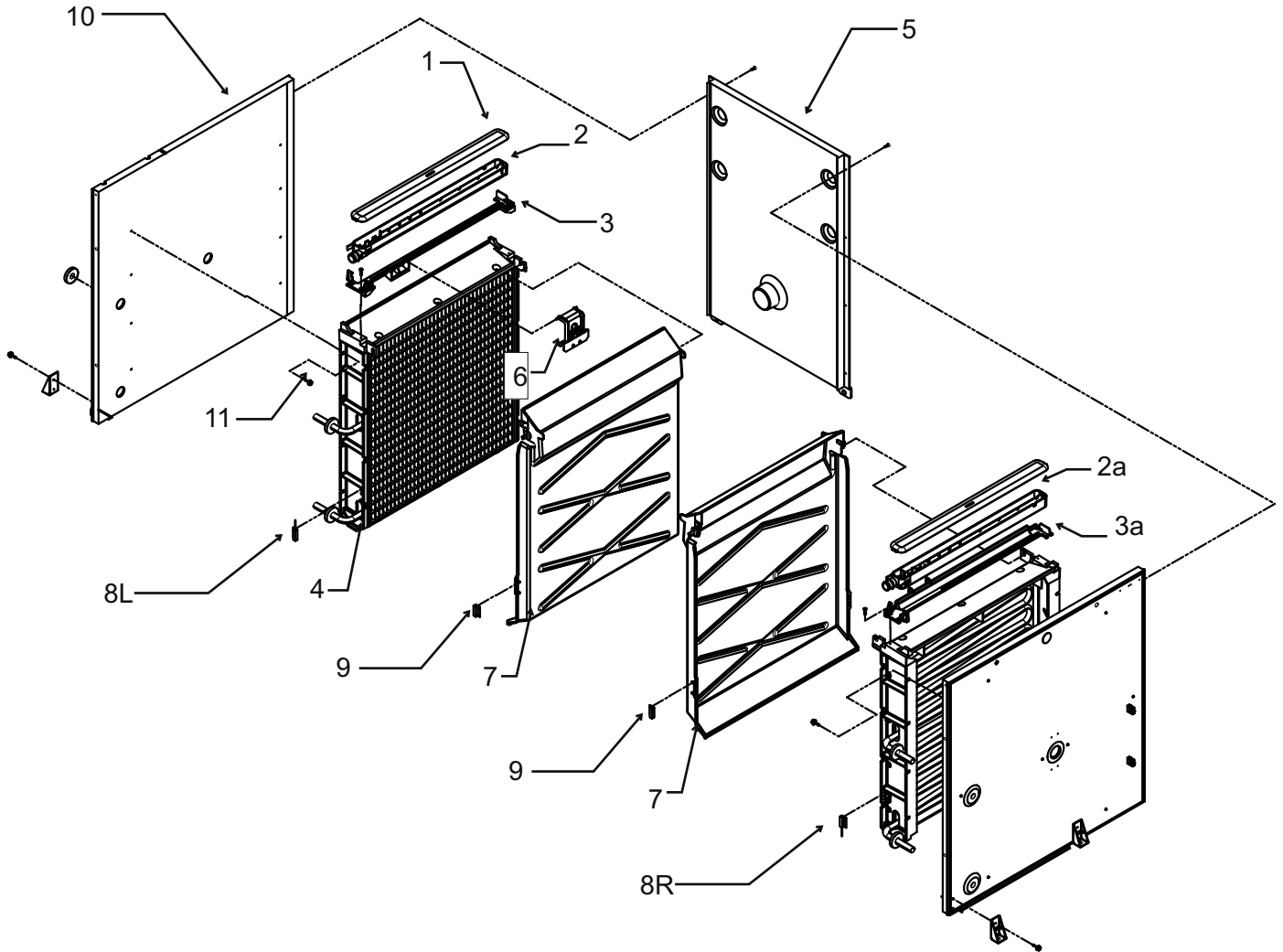

Item Number	Part Number	Description	8L	11-0563-06	Curtain switch, left
1	02-4065-01	Water distributor cover	8R	11-0563-03	Curtain switch, right
2	02-4064-01	Water distributor, left	9	11-0563-02	Curtain switch magnet
2a	02-4064-02	Water distributor, right	10	13-0943-01	Gasket tape
3	02-4205-01	Mounting bracket, left	11	03-3868-01	Screw
3a	02-4205-02	Mounting bracket, right	Note: Item 7 includes item 9, shipped loose.		
4	see table	Evaporator			

	small cube	medium cube
Right	A38627-023	A38627-024
Left	A38627-021	A38627-022

5	A39480-001	Back wall
6	A39031-021	Ice thickness sensor
7	02-4100-32	Curtain

EH330 and EH430 Service Parts

EH430 Evaporator Compartment

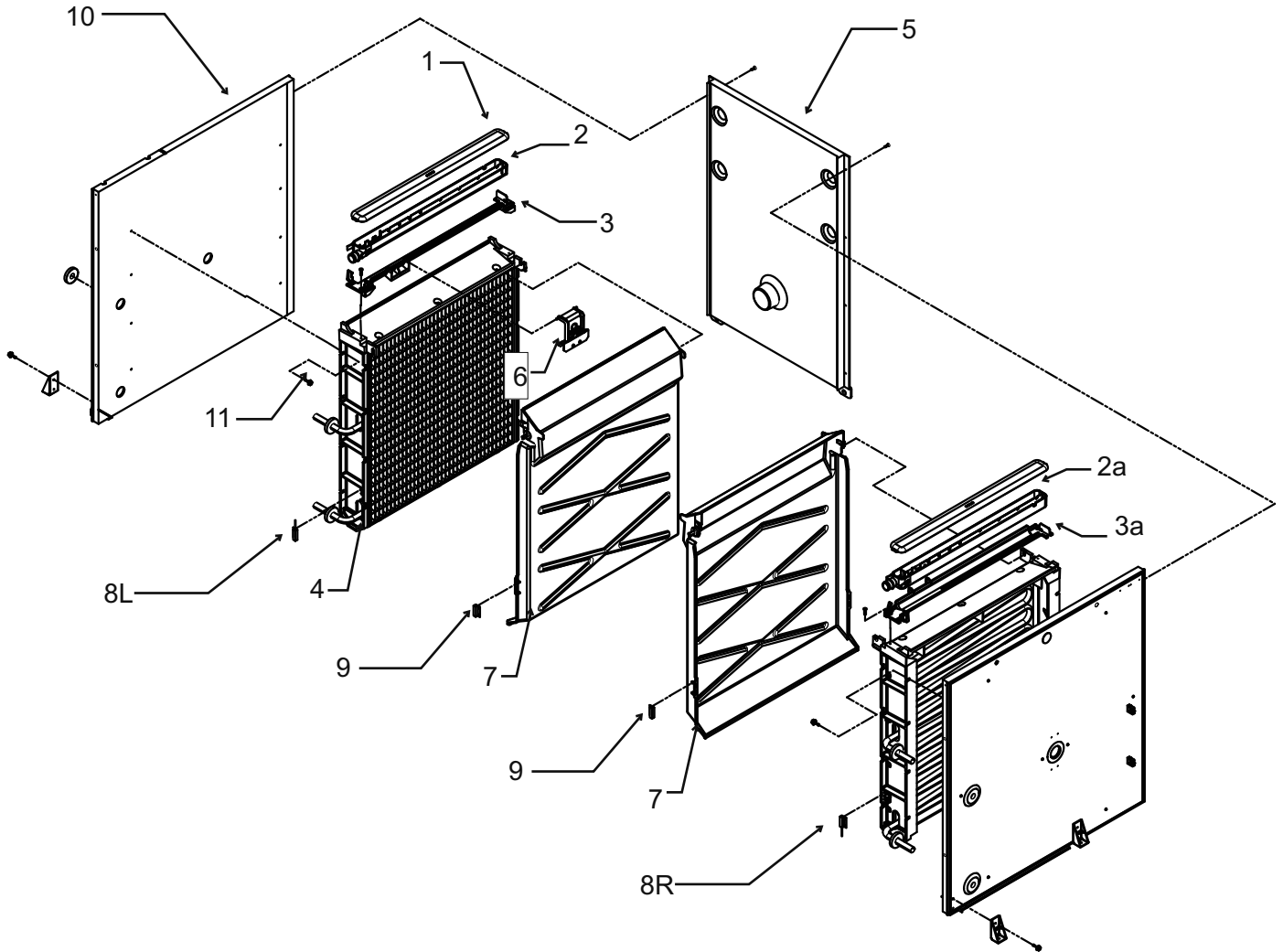

Item Number	Part Number	Description	8L	11-0563-06	Curtain switch, left
1	02-4065-01	Water distributor cover	8R	11-0563-03	Curtain switch, right
2	02-4064-01	Water distributor, left	9	11-0563-02	Curtain switch magnet
2a	02-4064-02	Water distributor, right	10	13-0943-01	Gasket tape
3	02-4205-01	Mounting bracket, left	11	03-3868-01	Screw
3a	02-4205-02	Mounting bracket, right	Note: Item 7 includes item 9, shipped loose.		
4	see table	Evaporator			

	small cube	medium cube
Right	A38628-023	A38628-024
Left	A38628-021	A38628-022

5	A38677-001	Back wall
6	A39031-021	Ice thickness sensor
7	02-4100-33	Curtain

EH330 and EH430 Service Parts

EH330 or EH430 Electrical

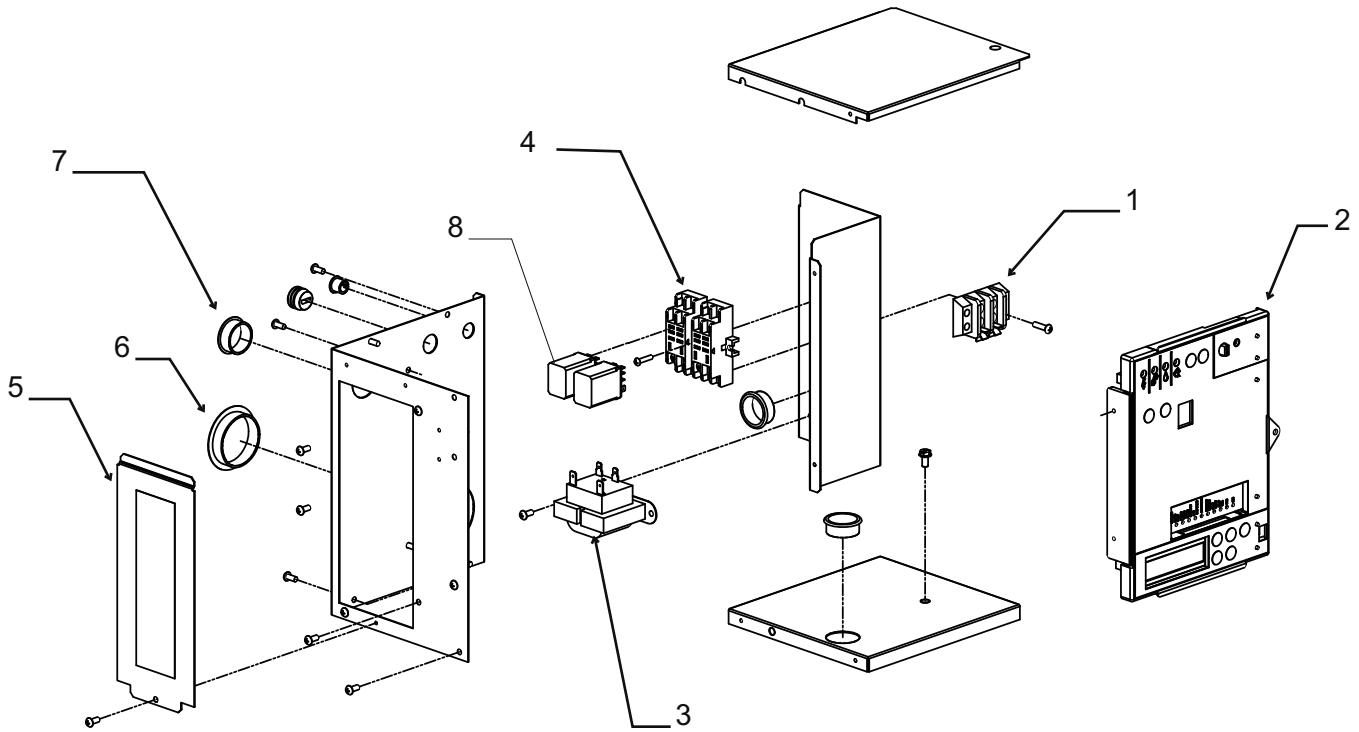

Item Number	Part Number	Description
1	12-2780-01	Terminal strip
2	11-0550-27	Controller
3	12-2924-01	Transformer
4	12-2949-02	Relay base
5	A39287-001	Cover
6	12-1213-15	Snap bushing
7	12-1213-11	Snap bushing
8	12-2949-01	Relay

Not Illustrated:

9	12-2954-01	Low voltage harness - to interconnecting wire
10	12-2943-01	High voltage harness (has large plug)
11	12-2940-01	Control power harness
12	12-1638-19	Power cord

EH330 and EH430 Service Parts

CP Cabinet

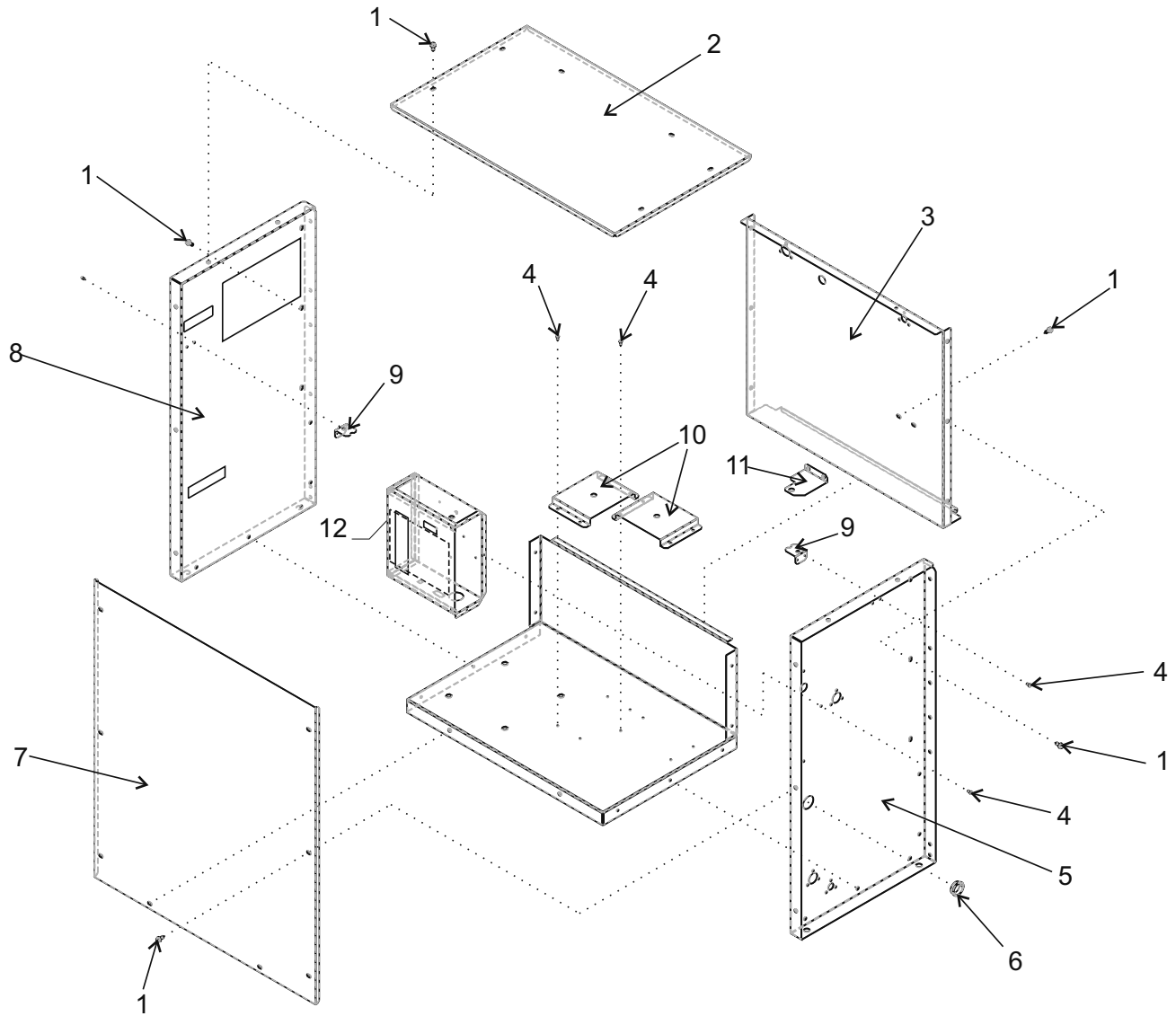

Item Number	Part Number	Description	Item Number	Part Number	Description
1	03-1645-01	Screw	10	A37948-001	Rec btm bracket - all or accumulator bracket - C1200CP or C1410CP
2	A37853-001	Top cover		A39319-001	Accumulator bracket, C1800CP or C2000CP
3	A37845-001	Back panel	11	A37949-001	Receiver top bracket
4	03-1531-01	Screw	12	A38430-001	Control box cover
5	A37829-001	Right side panel			
6	12-1213-20	Snap bushing			
7	A37896-001	Front cover			
8	A37829-002	Left side panel			
9	A37962-001	Service valve bracket			

EH330 and EH430 Service Parts

C1200CP Refrigeration System

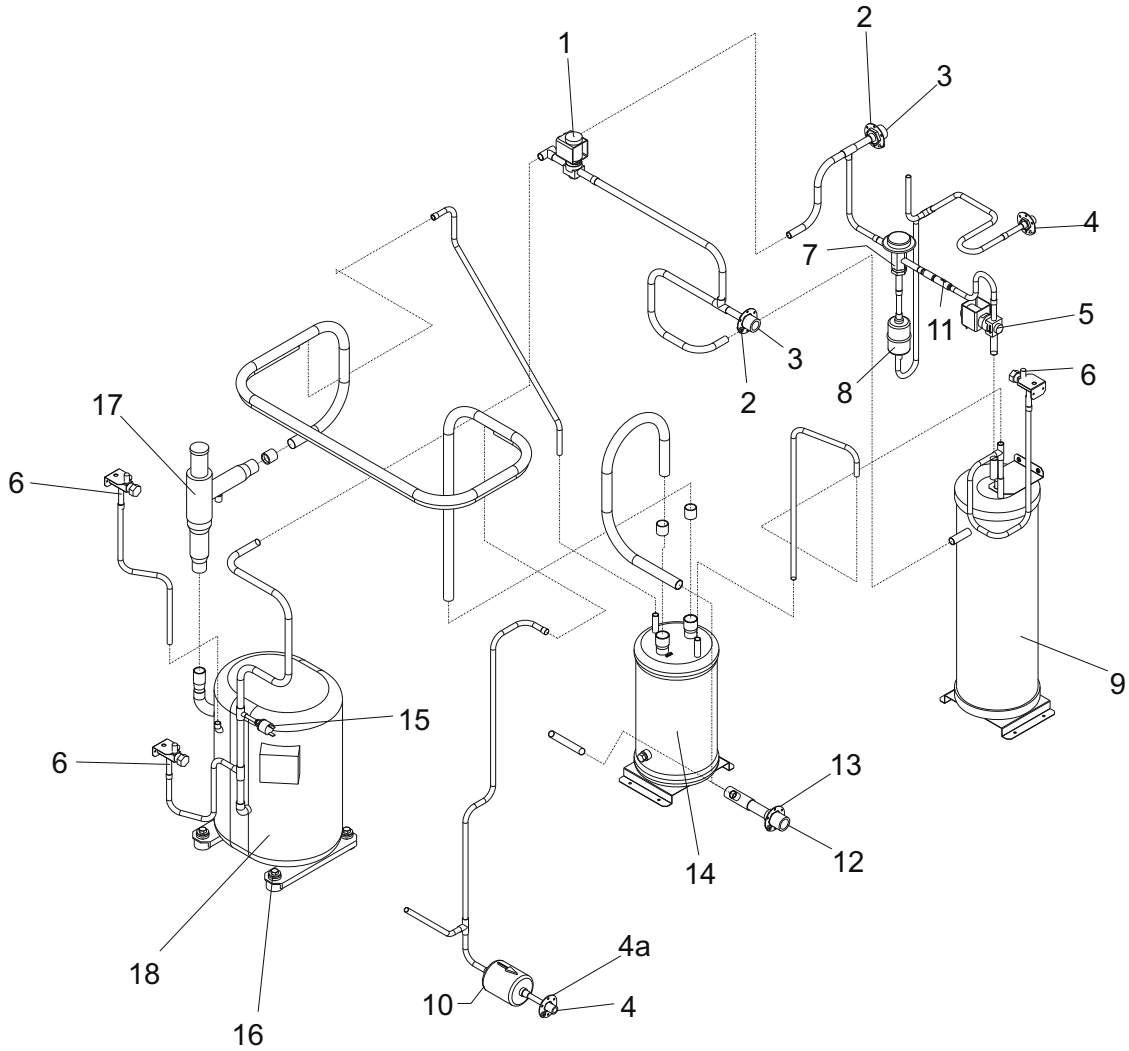

Item Number	Part Number	Description
1	11-0507-03	By pass valve
2	16-0701-14	Mounting flange
3	16-0850-01	Discharge quick connect
4	16-0850-03	Liquid quick connect
4a	16-0701-07	Mounting flange
5	11-0546-01	Liquid inlet valve
6	16-0832-20	Access valve
7	11-0422-22	Headmaster
8	02-3231-02	Filter
9	16-1085-01	Receiver
10	02-3319-02	Filter drier
11	16-1029-01	Check valve
12	16-0850-04	Suction quick connect
13	16-0701-18	Mounting flange
14	16-0801-22	Accumulator
15	11-0501-22	Hi pressure cut out
16	18-2300-27	Mounting grommet
	18-2300-26	Sleeve
	03-1406-07	Washer
	03-1404-15	Cap screw
17	16-1096-22	CPR valve
18	Compressors	

C1200CP-32	single phase	18-8750-22
C1200CP-2	three phase	18-8750-24

All compressors are 208-230 volt, 60 Hz.
 Single phase compressors include starting components. All include a drier and crankcase heaters.

EH330 and EH430 Service Parts

C1410CP Refrigeration Systems

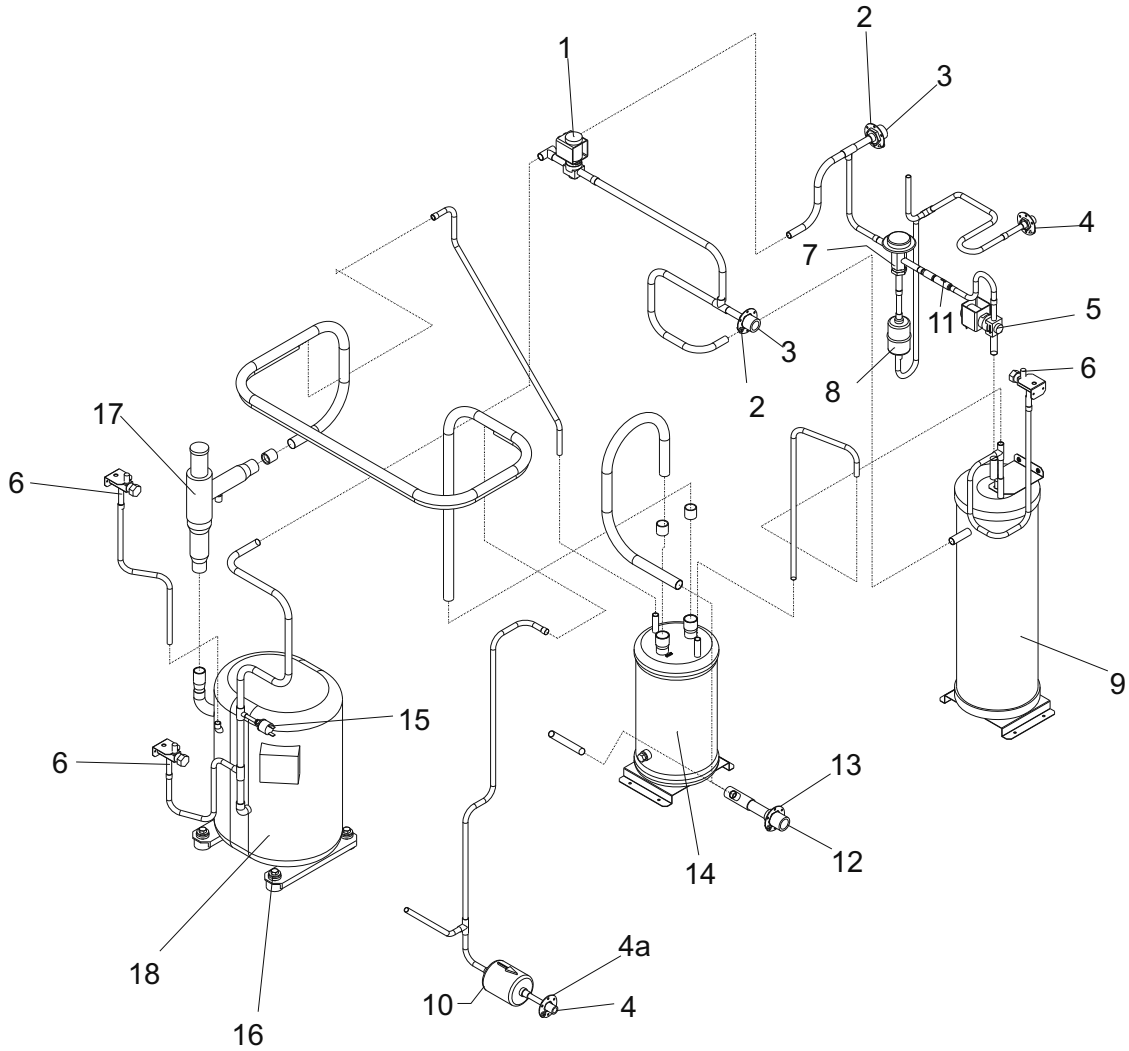

Item Number	Part Number	Description
1	11-0507-03	By pass valve
2	16-0701-14	Mounting flange
3	16-0850-01	Discharge quick connect
4	16-0850-03	Liquid quick connect
4a	16-0701-07	Mounting flange
5	11-0546-01	Liquid inlet valve
6	16-0832-20	Access valve
7	11-0422-22	Headmaster
8	02-3231-02	Filter
9	16-1085-01	Receiver
10	02-3319-02	Filter drier
11	16-1029-01	Check valve
12	16-0850-04	Suction quick connect
13	16-0701-18	Mounting flange
14	16-0801-22	Accumulator
15	11-0501-22	Hi pressure cut out
16	18-2300-27	Mounting grommet
	18-2300-26	Sleeve
	03-1406-07	Washer
	03-1404-15	Cap screw
17	16-1096-22	CPR valve
18	Compressors	
	C1410CP-32	single phase 18-8749-22
	C1410CP-2	three phase 18-8749-24

All compressors are 208-230 volt, 60 Hz.
 Single phase compressors include starting components. All include a drier and crankcase heaters.

EH330 and EH430 Service Parts

C1800CP Refrigeration System

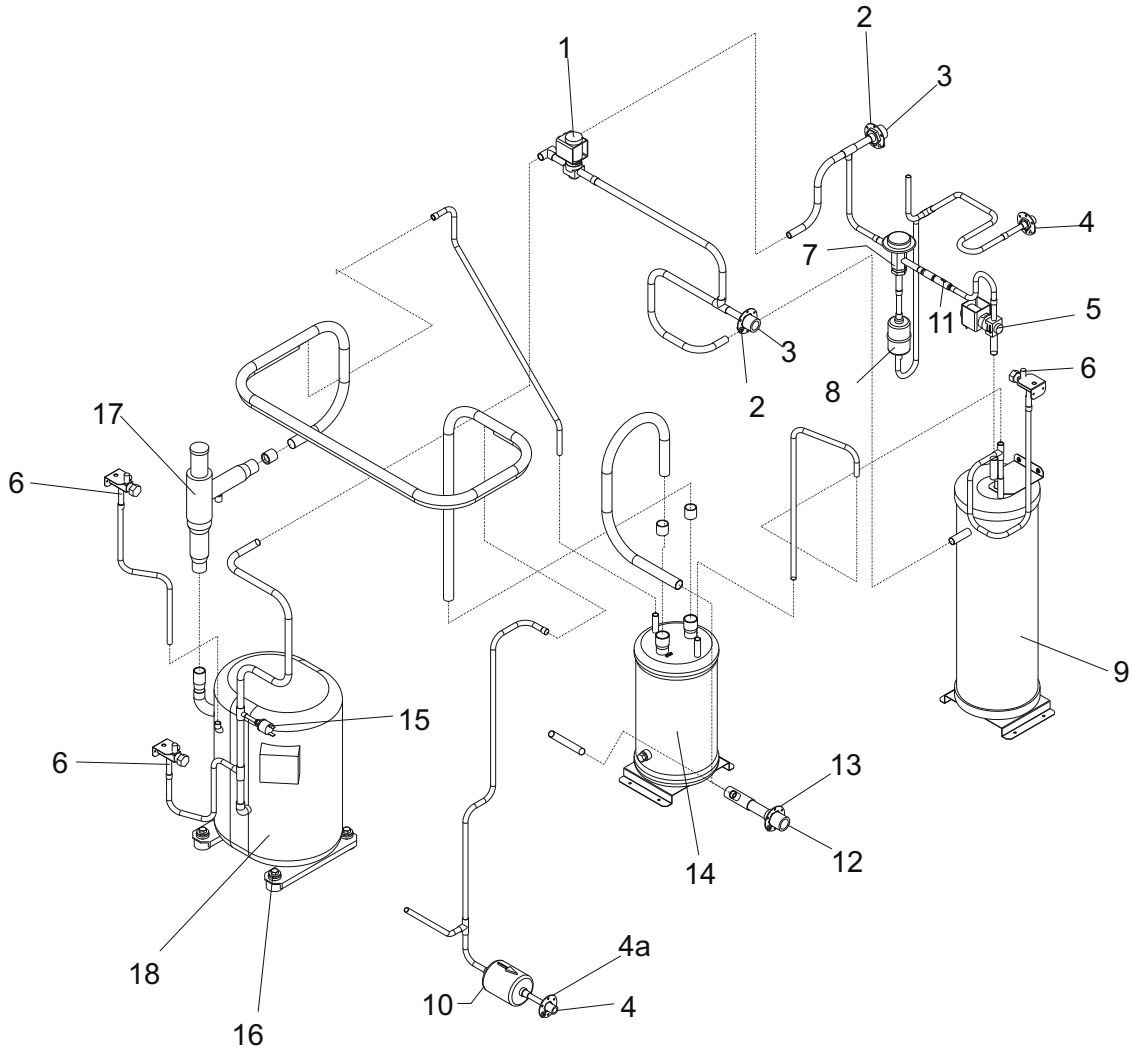

Item Number	Part Number	Description	Part Number	Description
1	11-0507-03	By pass valve	13	16-0701-18 Mounting flange
2	16-0701-14	Mounting flange	14	16-1122-21 Accumulator
3	16-0850-01	Discharge quick connect	15	11-0501-22 Hi pressure cut out
4	16-0850-03	Liquid quick connect	16	18-2300-27 Mounting grommet
4a	16-0701-07	Mounting flange		18-2300-26 Sleeve
5	11-0546-01	Liquid inlet valve		03-1406-07 Washer
6	16-0832-20	Access valve		03-1404-15 Cap screw
7	11-0422-22	Headmaster	17	16-1096-22 CPR valve
8	02-3231-02	Filter	18	Compressors
9	16-1085-01	Receiver		
10	02-3319-02	Filter drier		
11	16-1029-01	Check valve		
12	16-0850-04	Suction quick connect		

C1800CP-32	single phase	18-8930-24
C1800CP-2	three phase	18-8930-25

All compressors are 208-230 volt, 60 Hz.
 Single phase compressors include starting components. All include a drier and crankcase heaters.

EH330 and EH430 Service Parts

C2000CP Refrigeration System

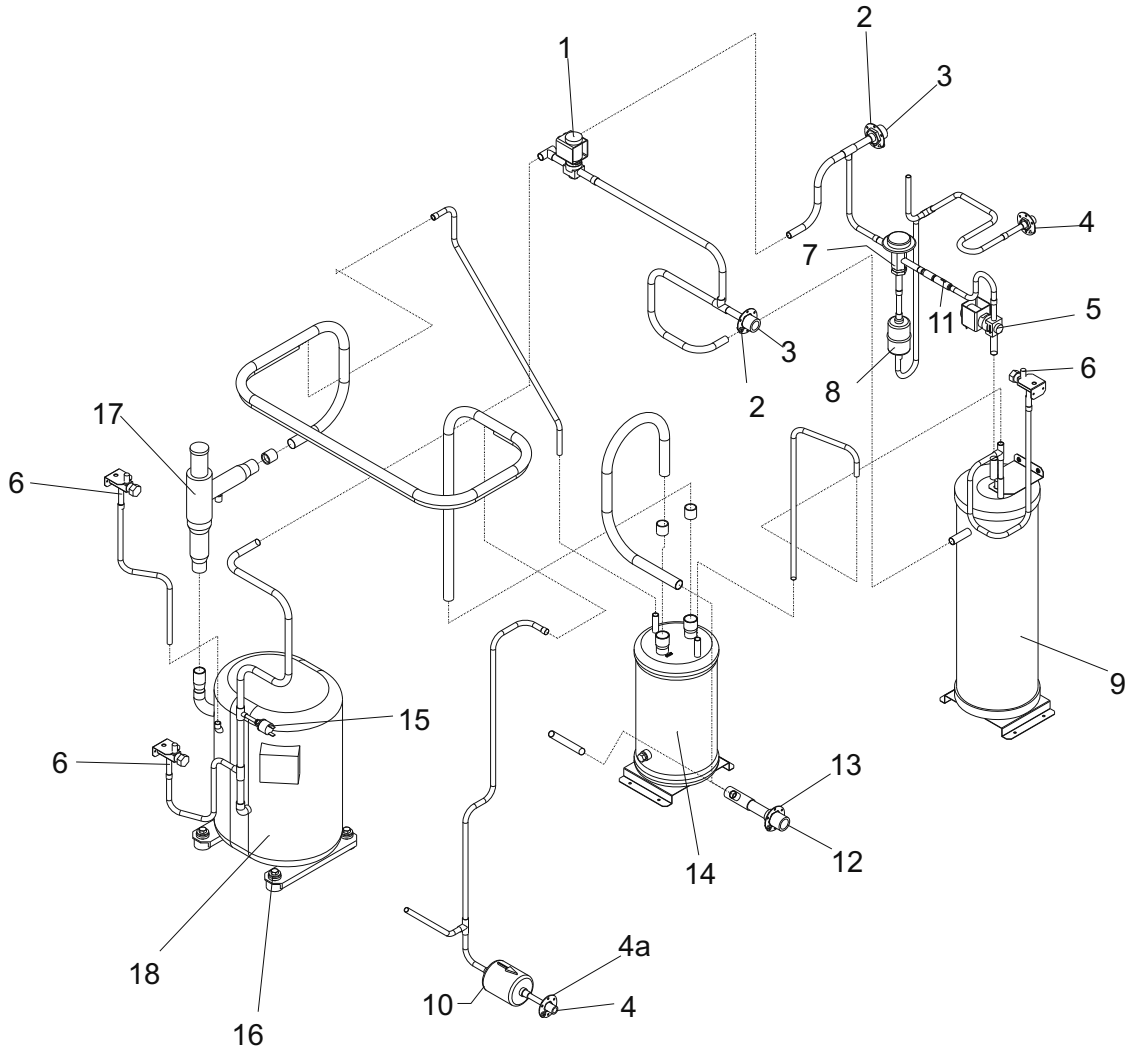

Item Number	Part Number	Description
1	11-0507-03	By pass valve
2	16-0701-14	Mounting flange
3	16-0850-01	Discharge quick connect
4	16-0850-03	Liquid quick connect
4a	16-0701-07	Mounting flange
5	11-0546-01	Liquid inlet valve
6	16-0832-20	Access valve
7	11-0422-22	Headmaster
8	02-3231-02	Filter
9	16-1085-01	Receiver
10	02-3319-02	Filter drier
11	16-1029-01	Check valve
12	16-0850-04	Suction quick connect
13	16-0701-18	Mounting flange
14	16-1122-21	Accumulator
15	11-0501-22	Hi pressure cut out
16	18-2300-27	Mounting grommet
	18-2300-26	Sleeve
	03-1406-07	Washer
	03-1404-15	Cap screw
17	16-1096-22	CPR valve
18	Compressors	
	C2000CP-32	single phase 18-8923-22
	C2000CP-2	three phase 18-8923-23

All compressors are 208-230 volt, 60 Hz.

Single phase compressors include starting components. All include a drier and crankcase heaters.

Prodigy Eclipse 1400, 1800, 2000 Service Parts

CP Control Box

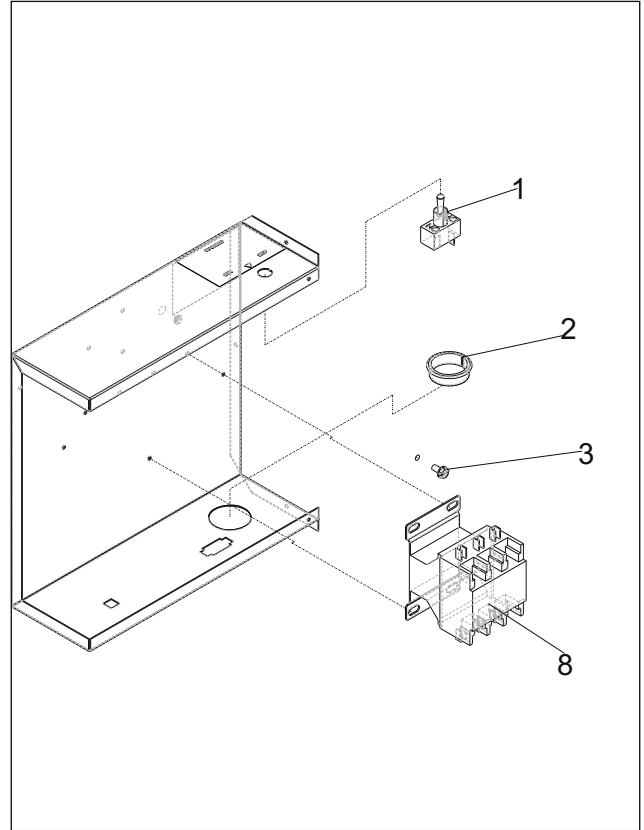
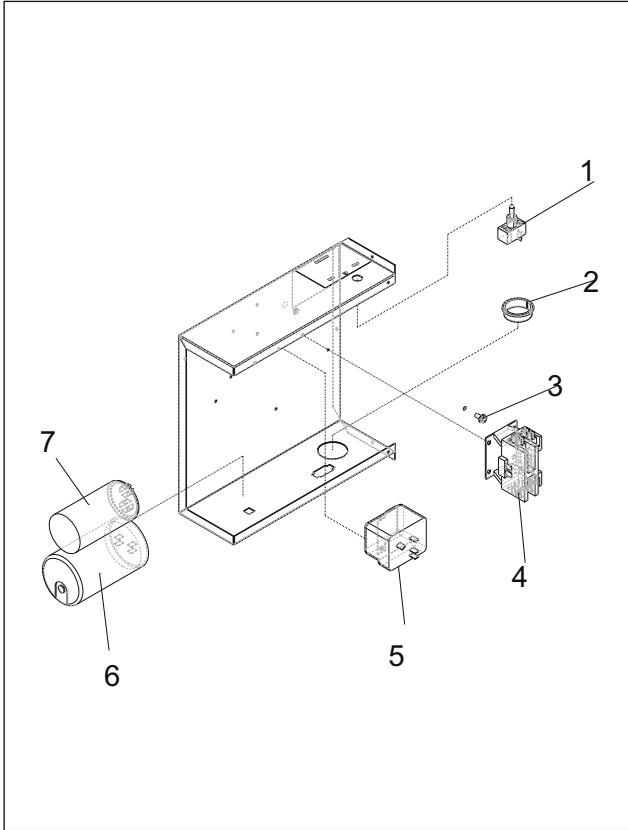

Item Number	Part Number	Description
1	12-2637-01	Toggle switch
2	12-1213-20	Snap bushing
3	03-1531-01	Mounting screw
4	12-2469-01	Single phase contactor

		C1410CP-32	C1800CP-32	C2000CP-32
5	Potential Relay	18-1903-46	18-1903-62	18-1903-62
6	Start Capacitor	18-1901-48	18-1901-27	18-1901-27
7	Run Capacitor	18-1902-55	18-1902-27	18-1902-27

8	12-2533-01	Three phase Contactor
Not Shown:		
9	12-2836-02	Transformer, 230 to 24

EH330 and EH430 Service Parts

Remote Condensers

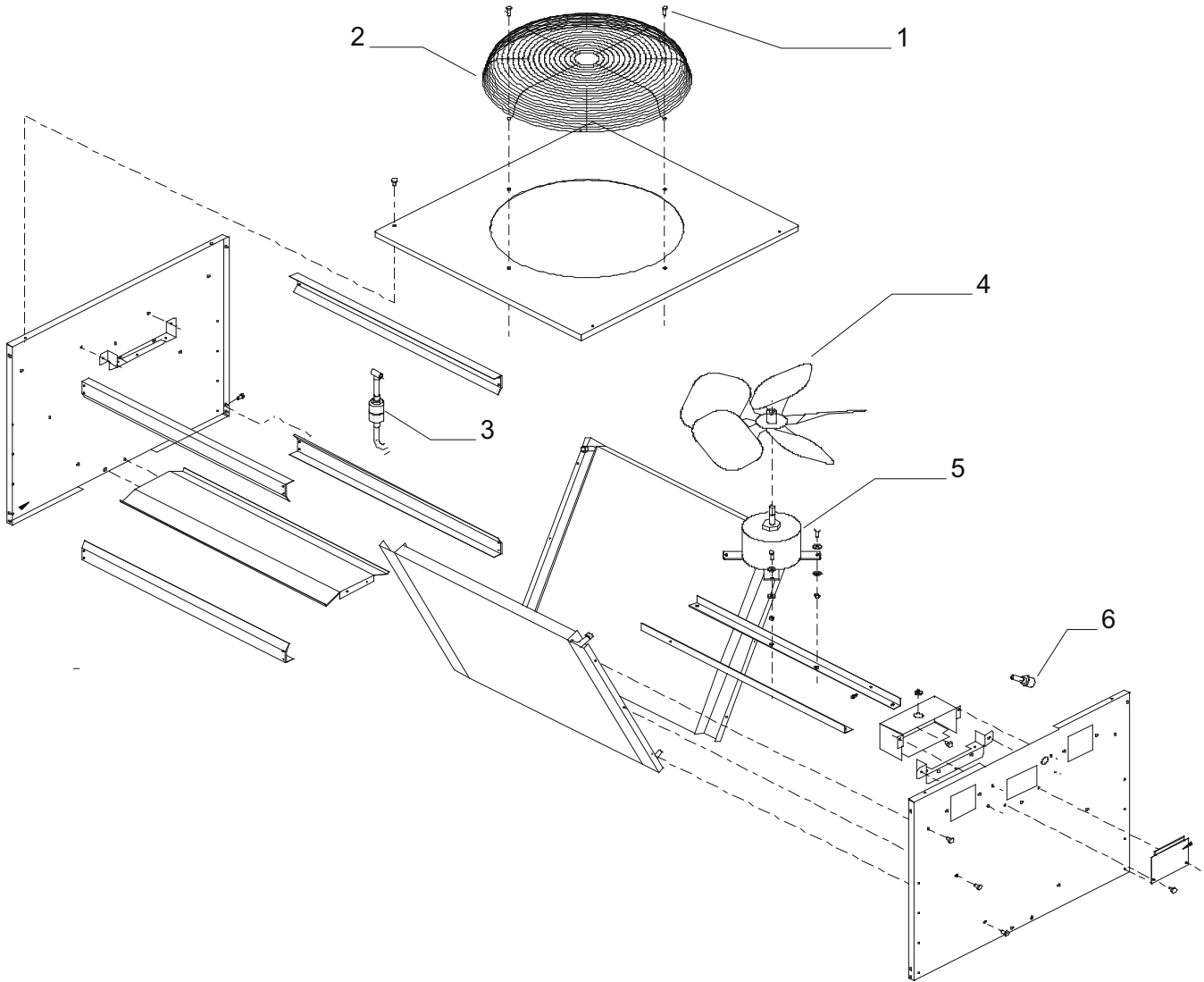

Model ERC1086

Item Number	Part Number	Description
1	03-1405-08	Screw
2	02-3575-01	Fan guard
3	02-3231-03	Filter
4	18-8816-01	Fan blade
5	12-2651-01	Fan motor
6	16-1057-04	Quick connect, disch
	16-1057-03	Quick connect, liquid

Not Shown:

A37169-001	Leg
A37170-001	Leg brace
03-1645-01	Screw for legs

ERC2086

Item Number	Part Number	Description
1	03-1405-08	Screw
2	02-3770-01	Fan guard
3	02-3231-03	Filter
4	18-8820-01	Fan blade
5	12-2717-01	Fan motor
6	16-1057-04	Quick connect, disch
	16-1057-03	Quick connect, liquid

Not Shown:

A37169-001	Leg
A37296-001	Leg brace
03-1645-01	Screw for legs

EH330 and EH430 Wiring Diagrams

EH330 or EH430 Schematic Diagram

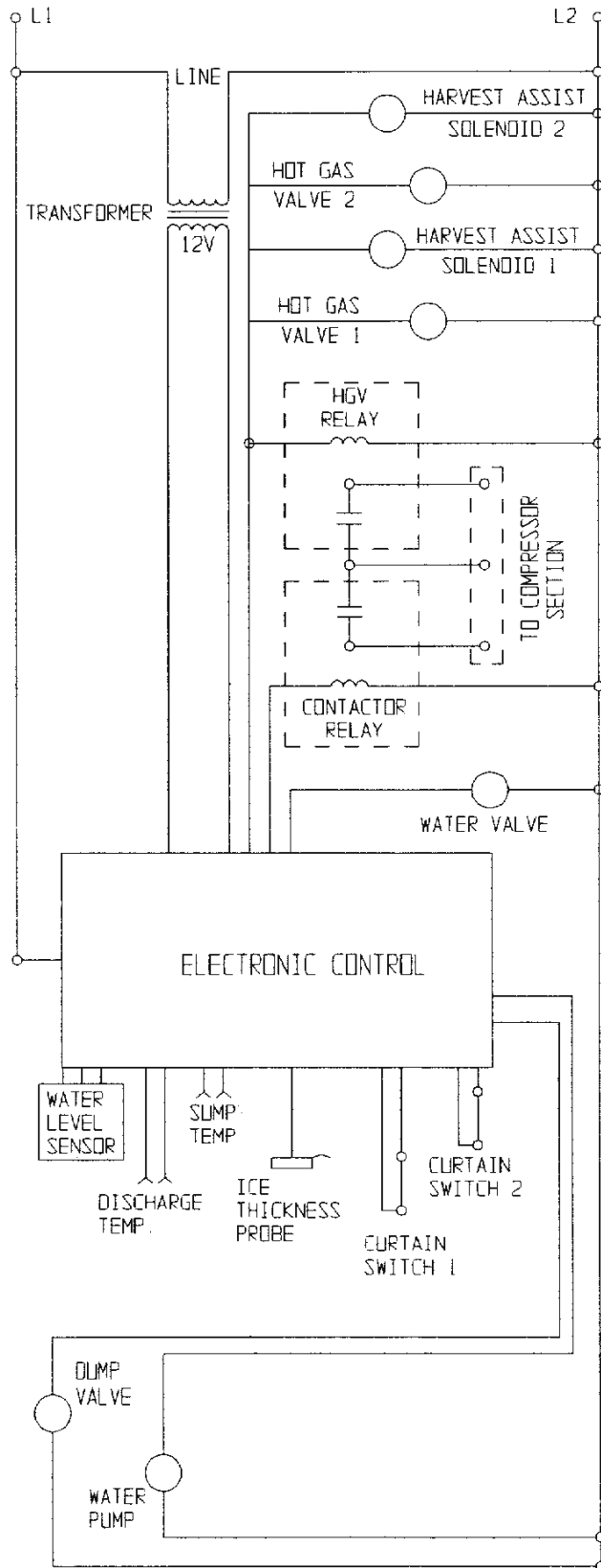

EH330 and EH430 Wiring Diagrams

EH330 or EH430 Wiring Diagram

17-3110-01

USE COPPER CONDUCTORS ONLY

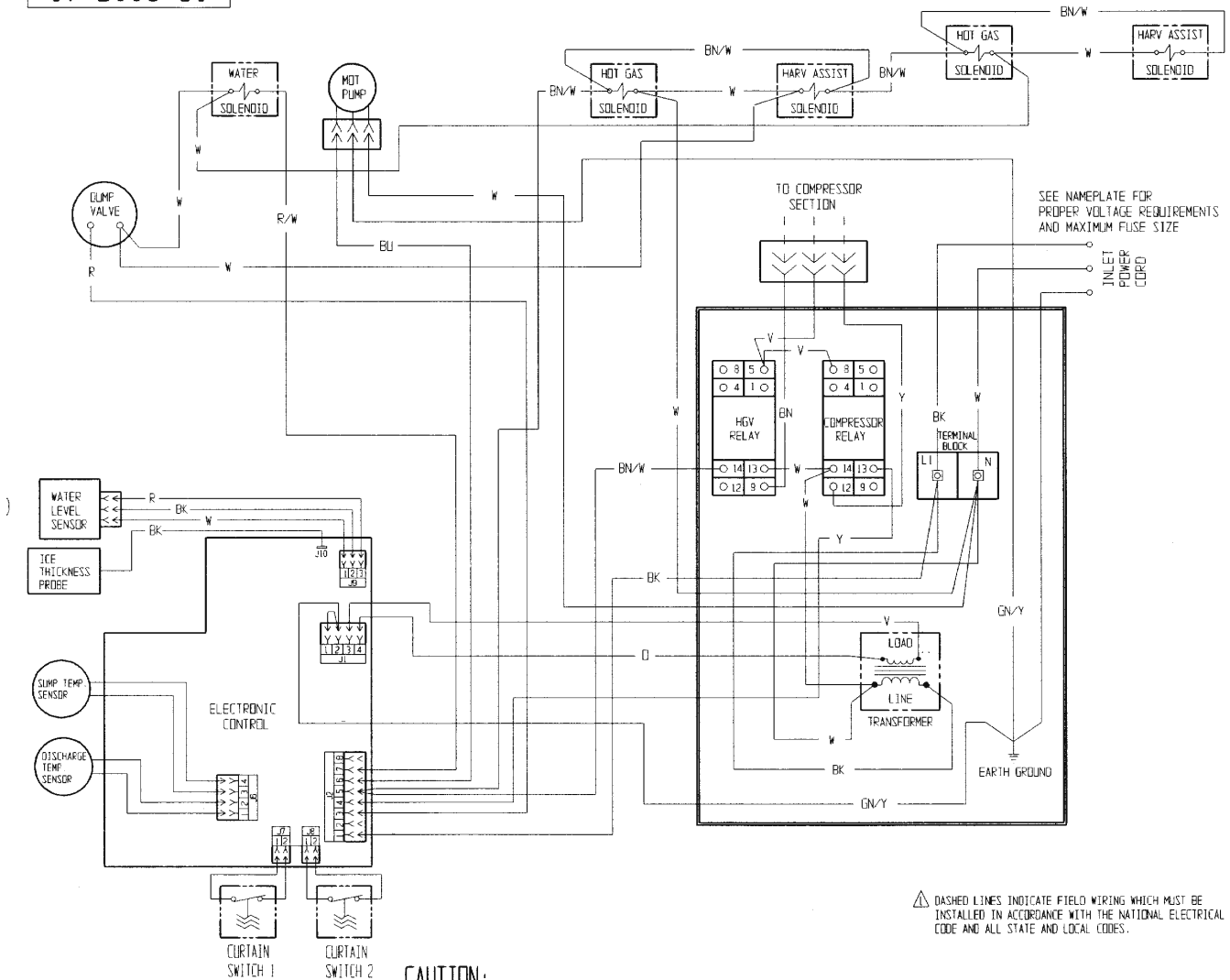

THIS UNIT MUST BE GROUNDED.

CAUTION: MORE THAN ONE DISCONNECT MEANS MAY BE REQUIRED TO DISCONNECT ALL POWER TO THIS UNIT.

△ DASHED LINES INDICATE FIELD WIRING WHICH MUST BE INSTALLED IN ACCORDANCE WITH THE NATIONAL ELECTRICAL CODE AND ALL STATE AND LOCAL CODES.

EH330 and EH430 Wiring Diagrams

CP Single Phase Schematic Diagram

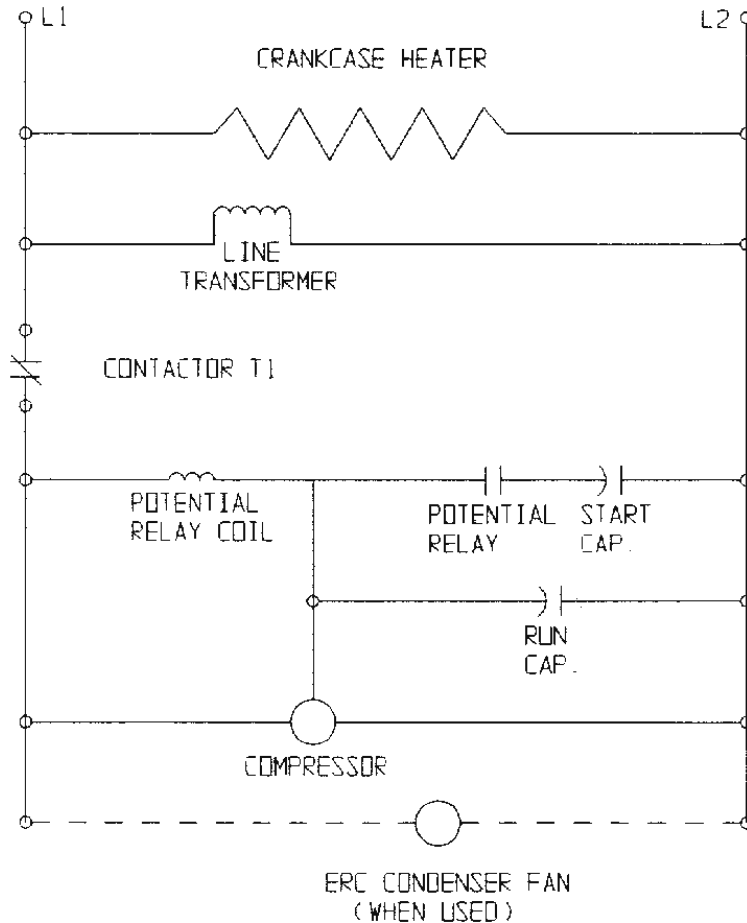
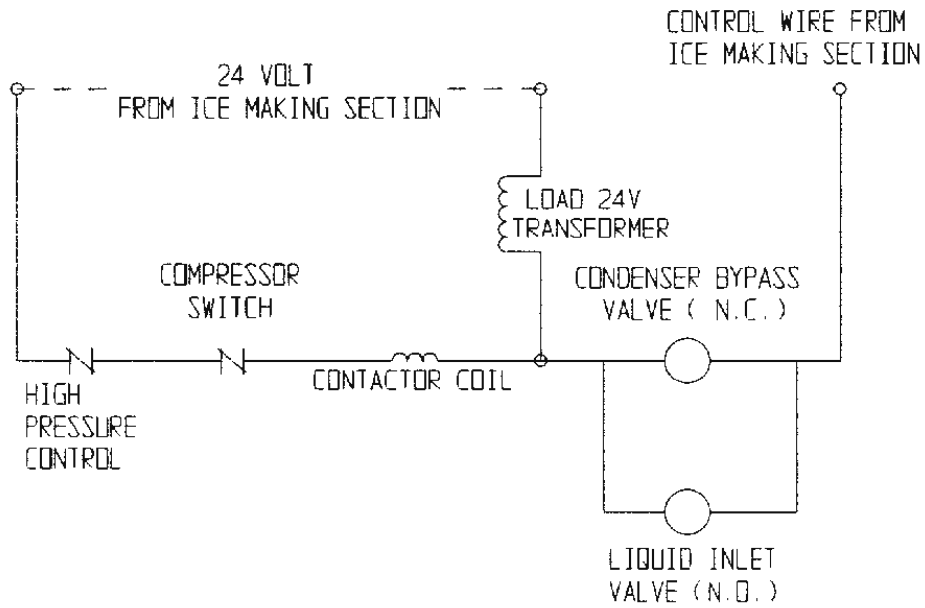

EH330 and EH430 Wiring Diagrams

CP Single Phase Wiring Diagram

17-3130-01

USE COPPER CONDUCTORS ONLY

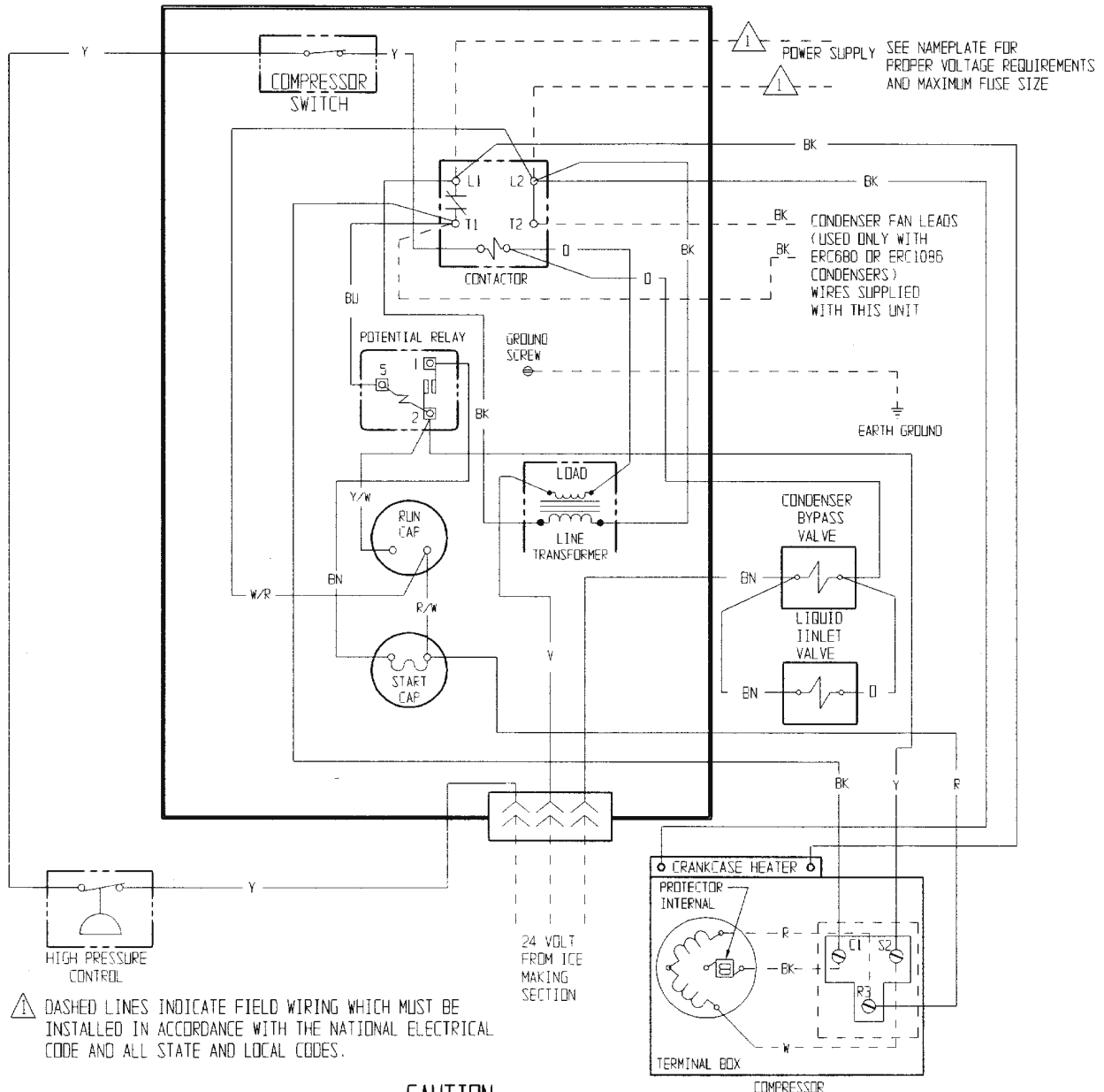

CAUTION:

MORE THAN ONE DISCONNECT MEANS MAY BE REQUIRED TO DISCONNECT ALL POWER TO THIS UNIT.

THIS UNIT MUST BE GROUNDED.

EH330 and EH430 Wiring Diagrams

CP Three Phase Wiring Diagram

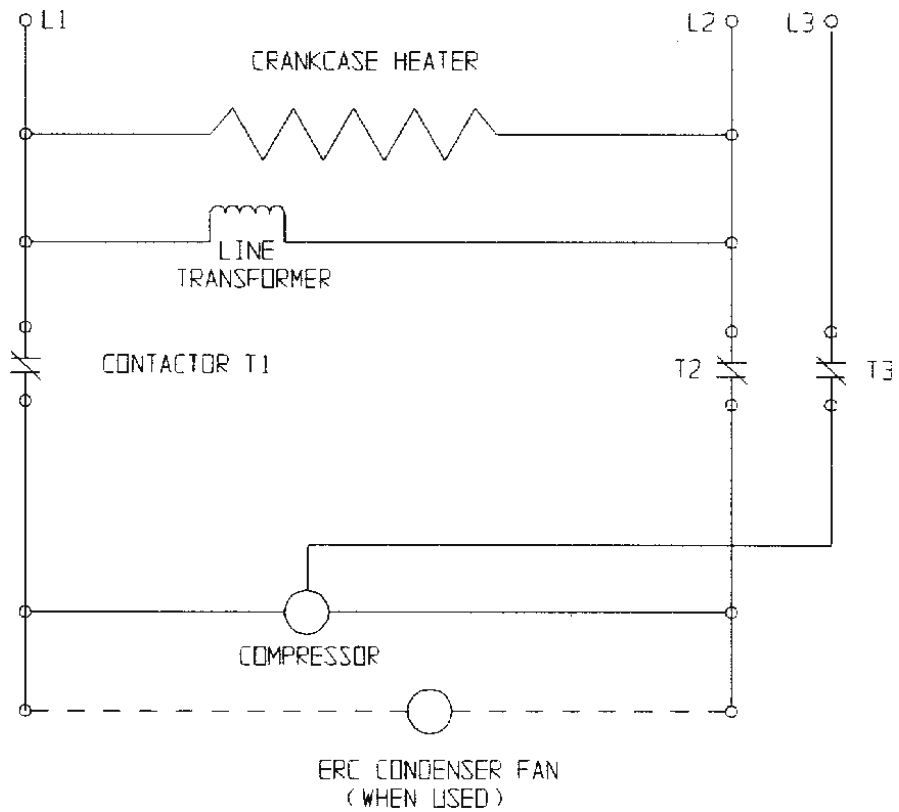
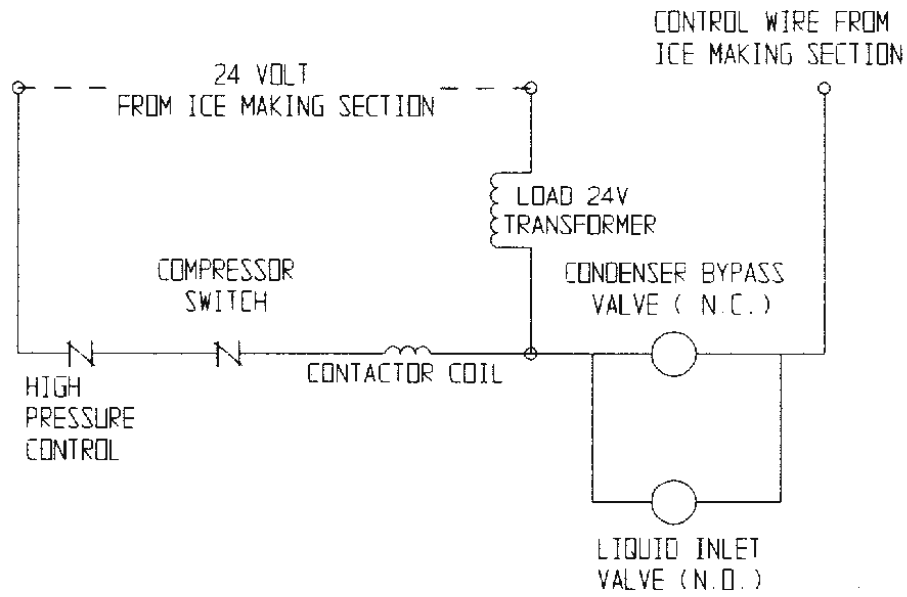

EH330 and EH430 Wiring Diagrams

CP Three Phase Schematic Diagram

17-3131-01

USE COPPER CONDUCTORS ONLY

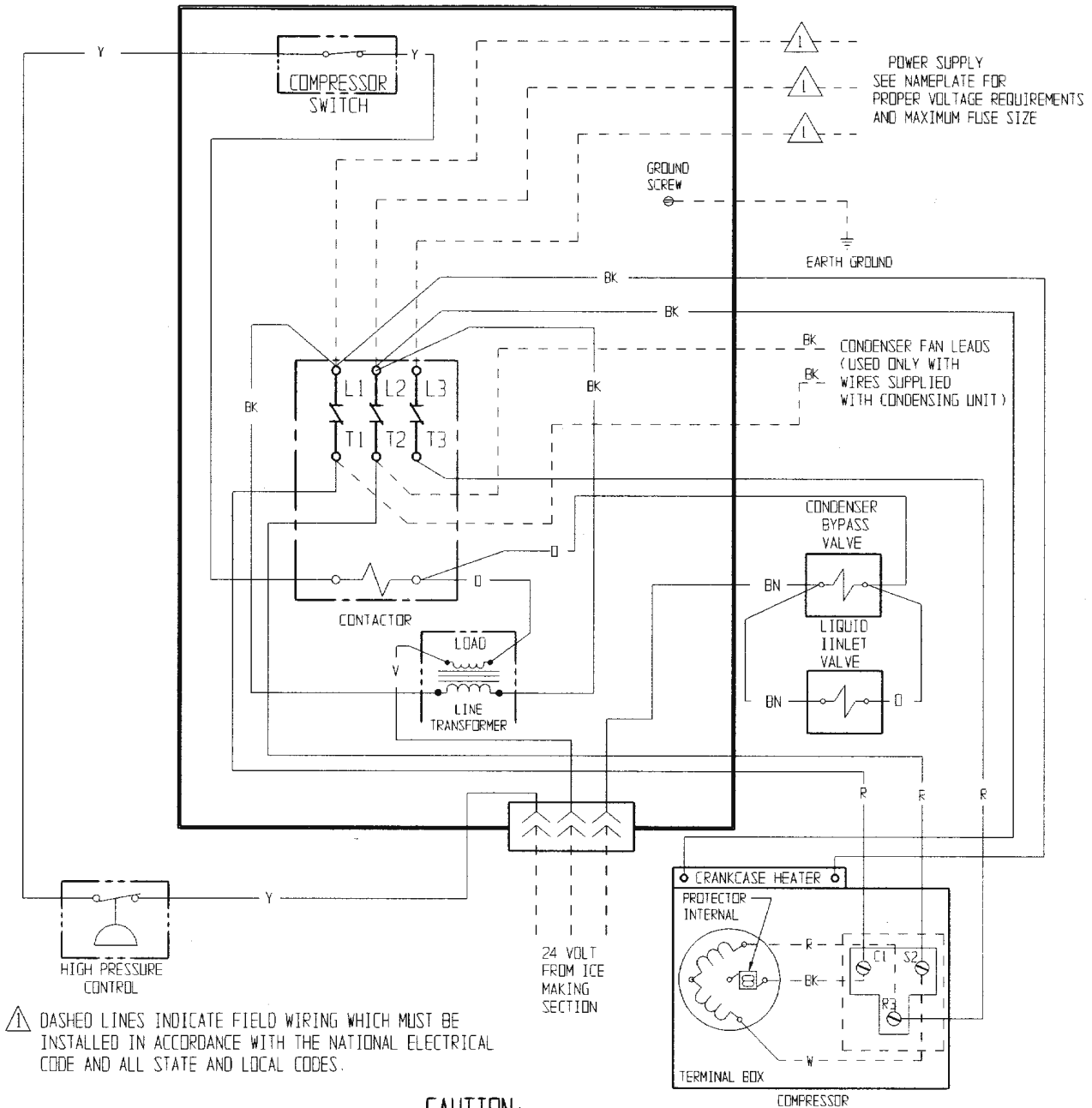

⚠ DASHED LINES INDICATE FIELD WIRING WHICH MUST BE INSTALLED IN ACCORDANCE WITH THE NATIONAL ELECTRICAL CODE AND ALL STATE AND LOCAL CODES.

CAUTION:

MORE THAN ONE DISCONNECT MEANS MAY BE REQUIRED TO DISCONNECT ALL POWER TO THIS UNIT.

THIS UNIT MUST BE GROUNDED.