

# FDE470 Service Parts

This parts lists contains part numbers for the service parts available for the FDE470.

The FDE470 has been manufactured in both 60 Hz and 50 Hz models.

The 60 Hz models are:

- FDE470AE-1A
- FDE470AS-1A

The 50 Hz models are:

- FDE470AE-6A
- FDE470AS-6A

Always check the model number of the ice machine being serviced to be certain that the parts ordered will be correct.

## Table of Contents

Cabinet .....	Page 2
Condensing Components.....	Page 3
Evaporator, Auger, Bearings & Water Seal.....	Page 4
Water And Drain System .....	Page 5
Bin Cover, Dispenser Motor, Electric Eyes .....	Page 6
Gear Reducer and Motor .....	Page 7
Control Box.....	Page 8
Wiring Diagrams.....	Page 9

# FDE470 Service Parts Cabinet

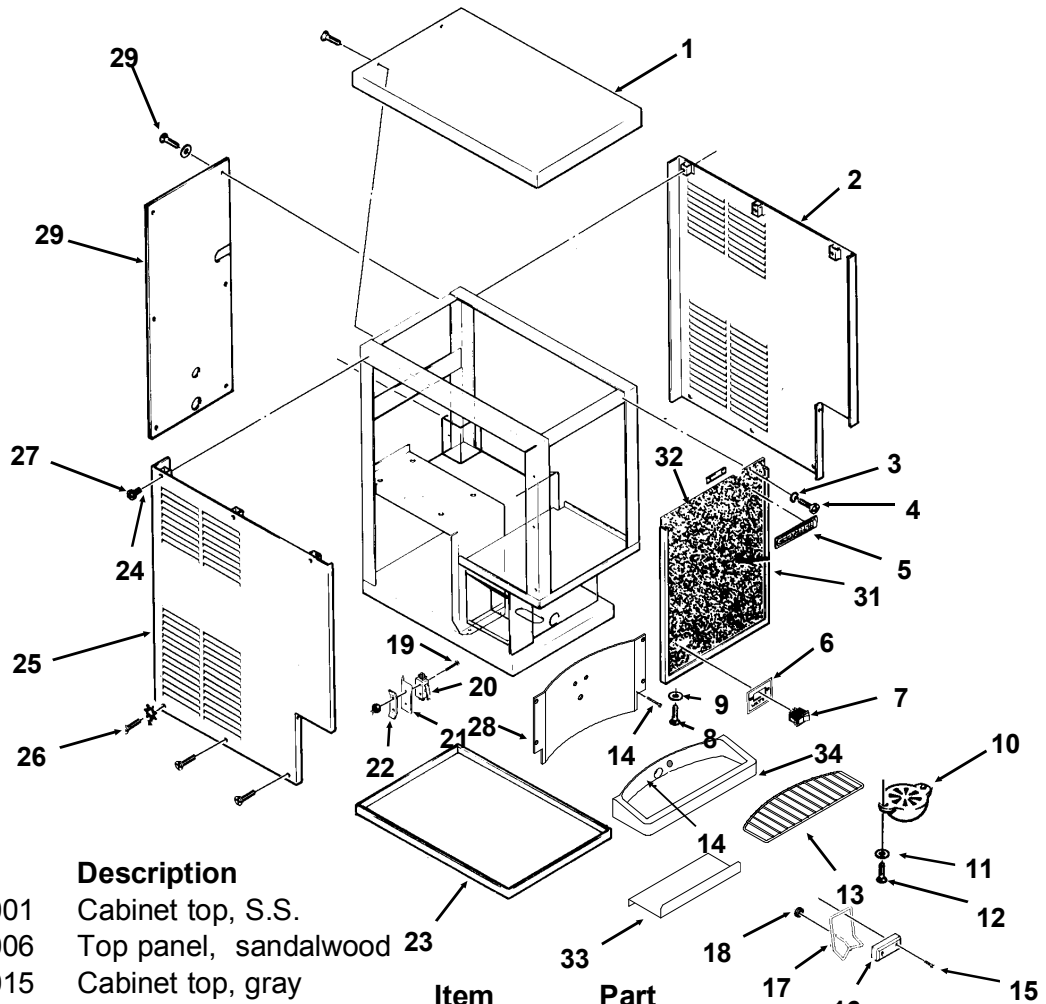

Item Number	Part Number	Description
1	A16317-001	Cabinet top, S.S.
	A16317-006	Top panel, sandalwood
	A16317-015	Cabinet top, gray
2	A21416-001	Cabinet side, S.S., Rt.
	A21416-004	Right side panel, sandalwd
	A21416-015	Right side panel, gray
3	13-0616-00	Rubber bumper
4	03-1404-11	Screw
5	15-0718-01	Emblem for sandalwood
	15-0718-02	Emblem for S.S. or gray
6	15-0621-01	Water decal
7	12-1377-00	Switch
8	03-1403-15	Screw
9	03-1417-27	Washer
10	02-1804-00	Spout
11	03-1407-03	Washer
12	03-1403-19	Screw
13	02-3302-01	Grill
14	03-1419-17	Screw
15	03-1419-09	Screw
16	02-1833-00	Adapter
17	A21544-000	Actuator arm
18	12-1213-04	Bushing
19	03-1403-09	Screw
20	12-1641-00	Switch
21	A22339-000	Insulation
22	03-0886-00	Nut
23	13-0566-00	Moulding
24	03-1417-27	Washer
25	A21415-004	Left side panel, sandalwoc
	A21415-015	Left side panel, gray
	A21415-001	Cabinet side, S.S., Lt.
26	03-1419-27	Screw
27	03-1404-09	Screw
28	02-3300-01	Splash panel
29	A21405-004	Back panel, sandalwood
	A21405-015	Back panel, gray
	A21405-001	Back panel, SS
30	03-1403-17	Screw
31	15-0507-00	Moulding trim
32	A27500-001	Front panel, SS
	A27500-003	Front panel, gray
	A27500-002	Front panel, brn vinyl cork
33	A35875-001	Bracket
34	02-3402-30	Sink

# FDE470 Service Parts

## Condensing Components

Item Number	Part Number	Description
1	18-8741-21	60 Hz compressor
	18-8741-26	50 Hz compressor
2	18-8741-27	Overload for 60 Hz
	18-8741-22	Overload for 50 Hz
3	18-8741-28	60 Hz relay
	18-8741-23	50 hz relay
3	18-8741-29	Start capacitor for 60 Hz
	18-8741-24	Start capacitor for 50 Hz
4	03-1647-01	Screw
	03-1417-12	Washer
	03-1407-07	Washer
	18-4700-28	Grommet
5	18-0108-40	Sleeve
6	16-0832-21	Access valve
6a	16-0832-03	Core cap
6b	16-0832-02	Stem cap
7	18-0422-00	Fan motor bracket
8	18-7200-02	60 Hz fan motor
	18-7200-03	50 Hz fan motor
9	18-8743-01	Fan blade
10	A36094-001	Fan shroud
11	18-8846-01	Condenser
12	02-3319-01	Drier

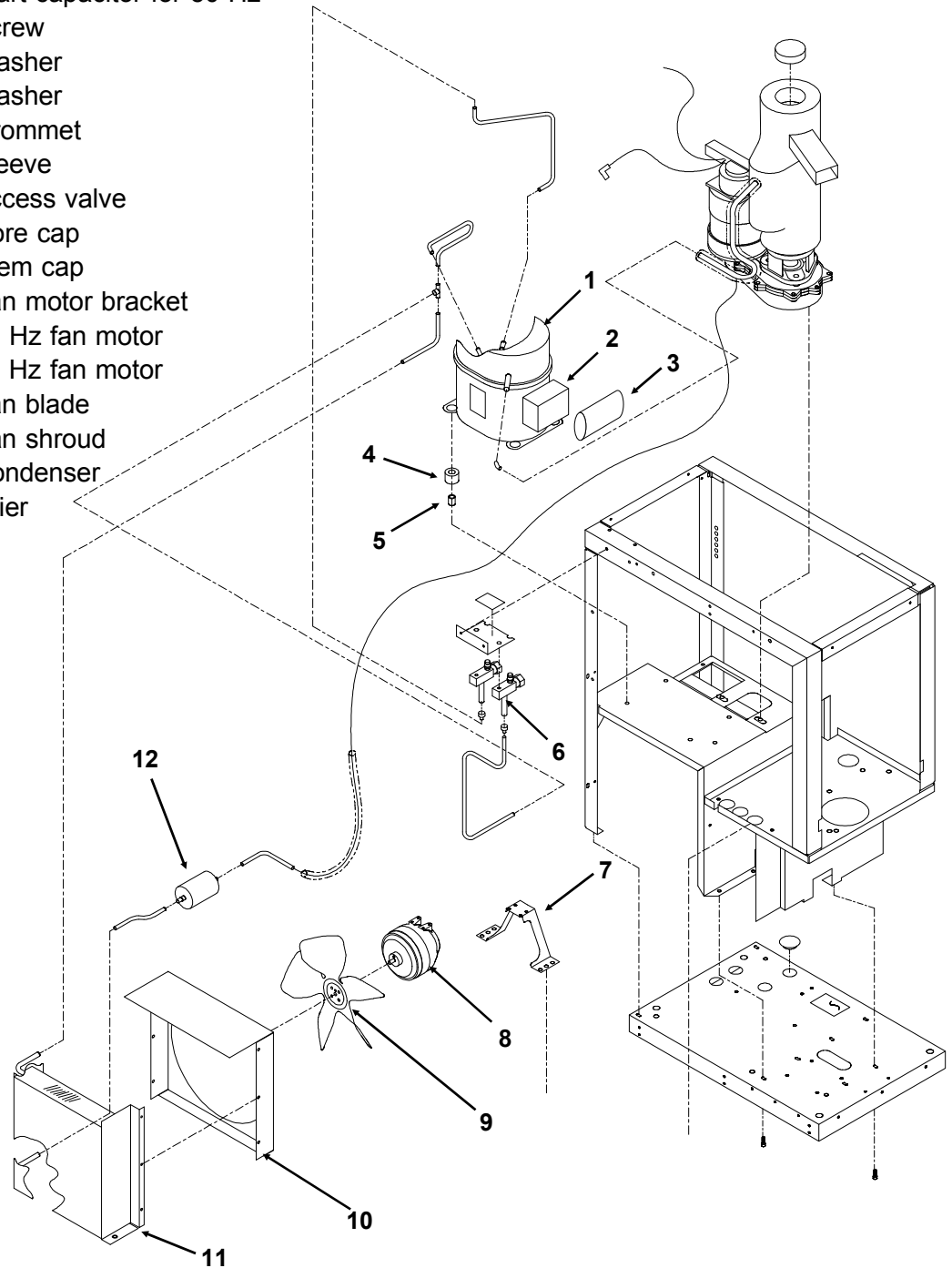

# FDE470 Service Parts

## Evaporator, Auger, Bearings & Water Seal

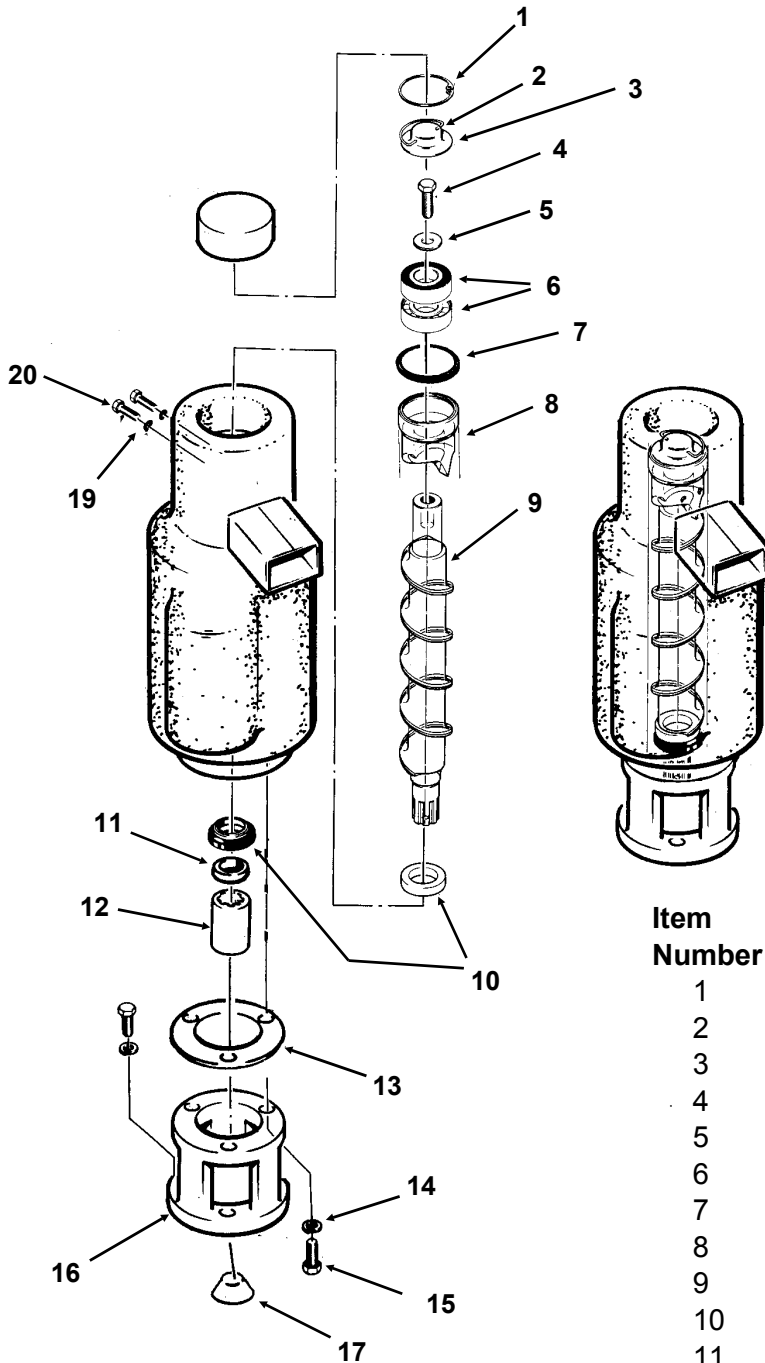

Item Number	Part Number	Description
1	03-1558-03	Retainer Ring
2	A08162-000	Cap hook
3	A07701-000	Cap
4	03-0758-00	Screw
5	A07699-000	Washer
6	02-1412-20	Top bearing set
7	13-0617-16	"O" ring
8	A14678-020	Breaker with bearing
9	02-4023-01	Auger
10	02-1300-01	Water seal
11	02-0417-20	Bottom bearing
12	A29915-002	Coupling
13	03-1505-00	Gasket
14	03-1410-04	Washer
15	03-1420-01	Cap screw
16	08-0595-01	Adapter
17	13-0709-01	Rubber drip shield
18	A36081-020	Evaporator
19	03-1417-07	Washer
20	03-1403-46	Screw

# FDE470 Service Parts

## Water And Drain System

Item Number	Part Number	Description
1	A37893-001	Vane Assembly
2	A38272-001	Bin Bottom Assy
3	02-3033-01	Hub Assembly
4	03-1409-22	Fiber Washer
5	A36118-001	Storage Bin
6	13-0895-01	Inlet water line requires 26"
7	03-1394-00	Pal Nut
8	12-1434-04	Water valve (60 hz)
	12-1434-05	Water valve (50 Hz)
9	16-0869-01	Barbed adapter
10	13-0674-02	Tubing, 12" req.
11	A33101-022	Water sensor
12	02-3402-30	Sink
13	02-3302-01	Grill for sink
14	13-0674-08	Tube, requires 12"
15	02-2814-10	Clamps
16	13-0079-03	Tube, overflow to drain, requires 12"
17	02-2814-08	Clamp
18	02-2814-07	Clamp
19	02-3371-20	Reservoir Assy
20	A36402-001	Reservoir Bracket
21	02-3371-21	Float and arm
21a	02-3266-03	Plunger/seat
22	03-1407-05	Plain Washer
23	03-1645-01	Hex Cap Screw
24	13-0674-09	Tube (to evap.)
25	A21433-000	Inlet fitting
26	16-0870-01	NPT to compr. fitting
27	16-0869-01	NPT barbed

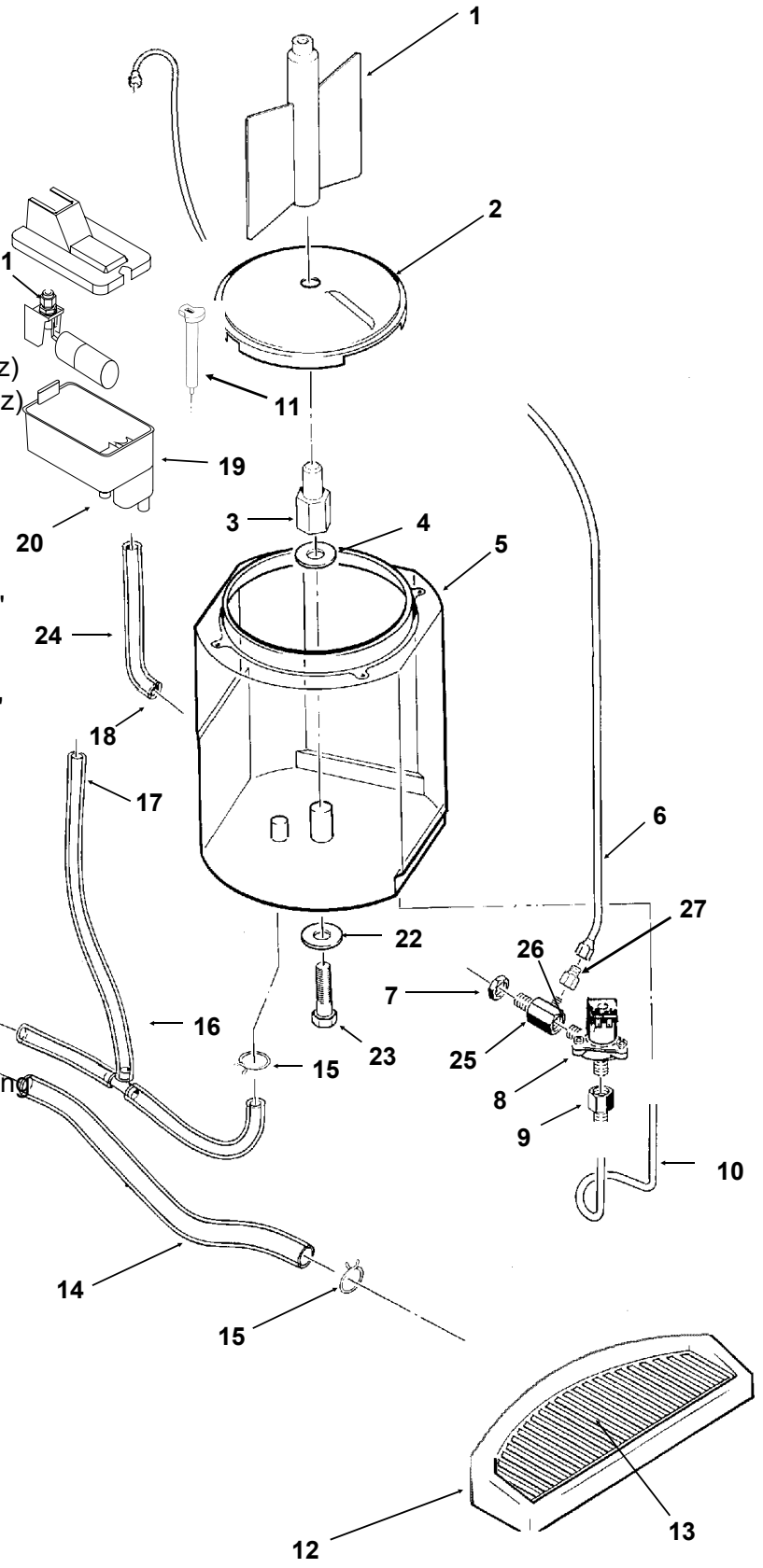

# FDE470 Service Parts

## Bin Cover, Dispenser Motor, Electric Eyes

Item Number	Part Number	Description
1	03-1403-15	Screw
2	03-1531-01	Screw
3	A35474-001	Motor Mtg. Bracket
4	02-3238-01	Bushing
5	03-0727-10	Thumbscrew
6	13-0866-01	Grommet
7	A35493-021	Electric eye set
8	02-3237-01	Bin top
9	02-3239-01	Nut
10	02-3241-01	Shaft
11	12-1610-01	Motor & gears 60 Hz
	12-1610-06	Motor & gears 50 Hz
12	02-1801-02	Strap
	A35483-021	Complete assembly 50 hz
	A35483-026	Complete assembly 50 hz

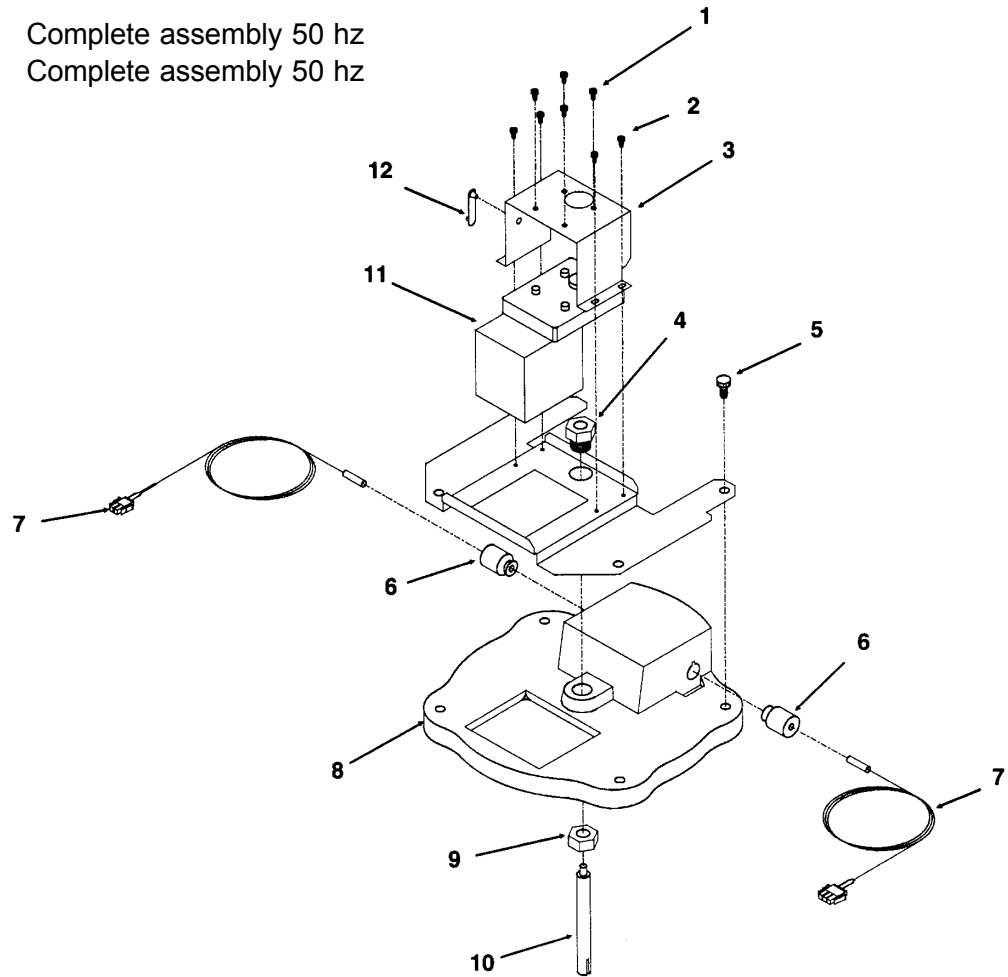

# FDE470 Service Parts

## Gear Reducer and Motor

Item Number	Part Number	Description
1	A27494-001	Centrifugal switch kit
2	12-2059-01	Switch
3	no number	Housing, part of item 1
4	03-1403-77	Screw
5	A30579-001	Shaft & actuator
6	03-1408-36	Washer
7	A38487-001	Motor housing kit
8	A28168-001	Cooling fan
9	no number	Part of item 10
10	A37707-021	60 Hz motor kit*
	A38501-001	50 Hz motor kit*
11	03-1408-08	Washer
12	02-1501-00	Bearing
13	02-3969-20	Grease seal (input)
14	02-1503-00	Grease seal (output)
15	A28165-021	Gear case cover
16	03-1408-21	Washer
17	03-1408-04	Washer
18	02-2445-01	Output shaft
19	03-1515-03	Retaining ring
20	03-1602-01	Woodruff key

\* includes items 7, 8, 9, 10, 11 and 12

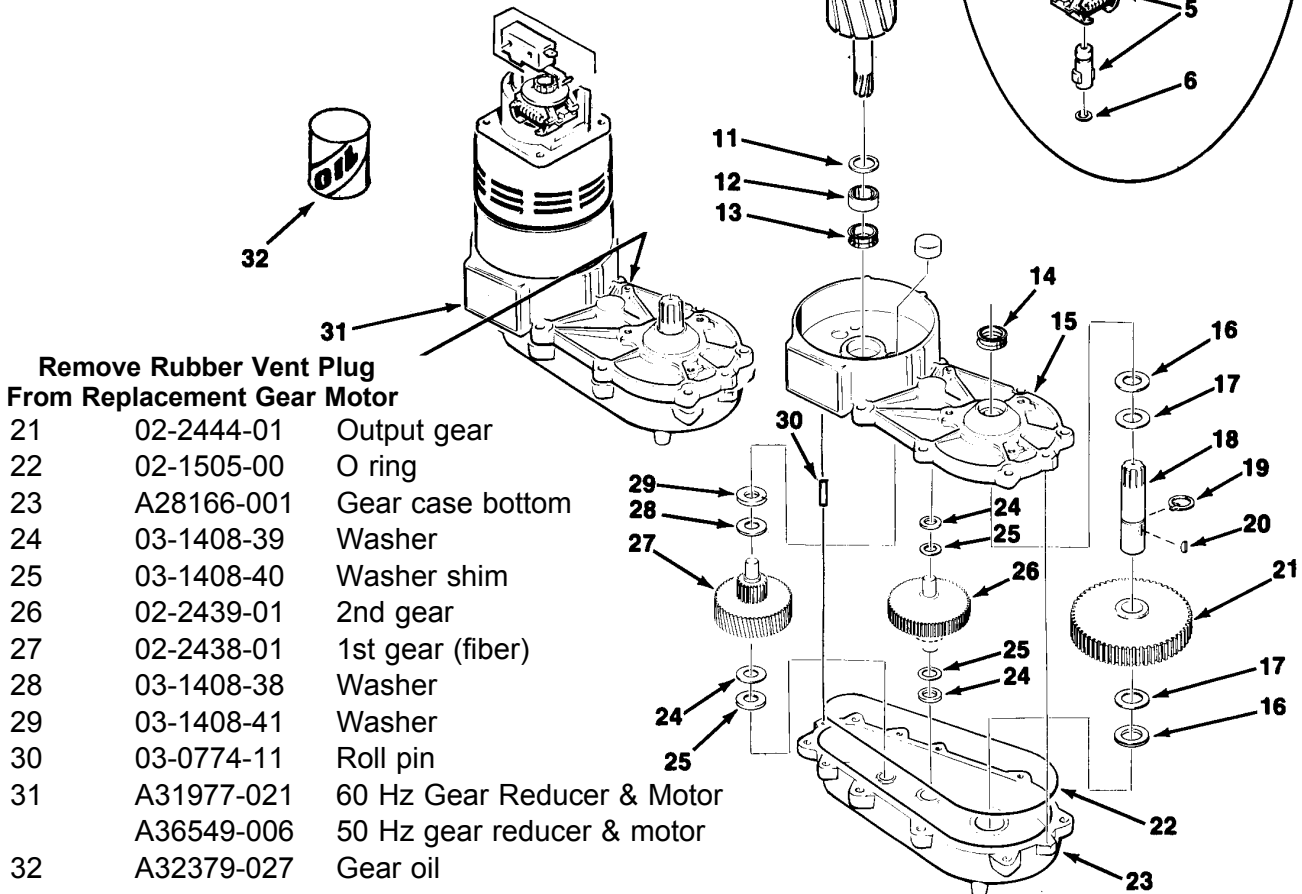

**Remove Rubber Vent Plug From Replacement Gear Motor**

21	02-2444-01	Output gear
22	02-1505-00	O ring
23	A28166-001	Gear case bottom
24	03-1408-39	Washer
25	03-1408-40	Washer shim
26	02-2439-01	2nd gear
27	02-2438-01	1st gear (fiber)
28	03-1408-38	Washer
29	03-1408-41	Washer
30	03-0774-11	Roll pin
31	A31977-021	60 Hz Gear Reducer & Motor
	A36549-006	50 Hz gear reducer & motor
32	A32379-027	Gear oil

# FDE470 Service Parts Control Box

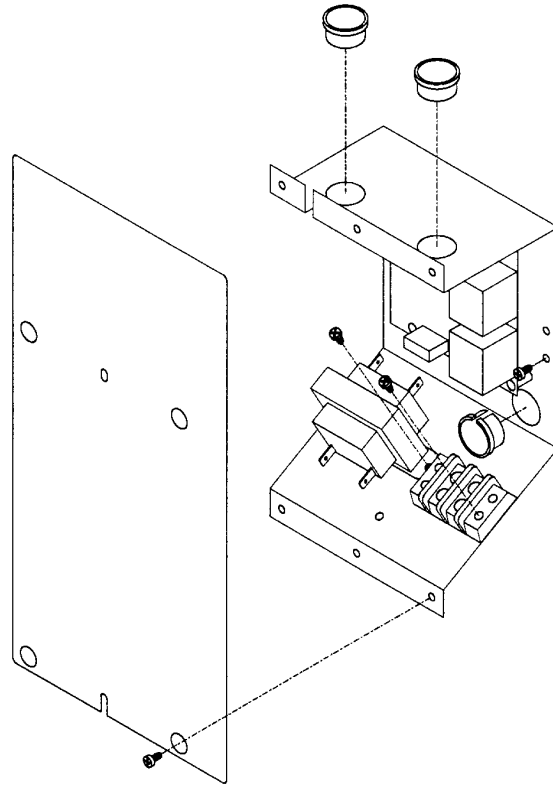

Item Number	Part Number	Description
1	12-1213-10	Snap bushing
2	A37750-021	Circuit board
3	12-0813-04	Terminal strip
4	03-1531-03	Screw
5	12-2285-21	Transformer 50 Hz
	12-2285-22	Transformer, 50 Hz
6	A35480-001	Control box cover
Not shown for FDE470A-1AG		
7	12-2391-01	Key lock switch



# FDE470 Service Parts Wiring Diagram FDE470AE-1A

△ = WIRE NUT

A36041-001

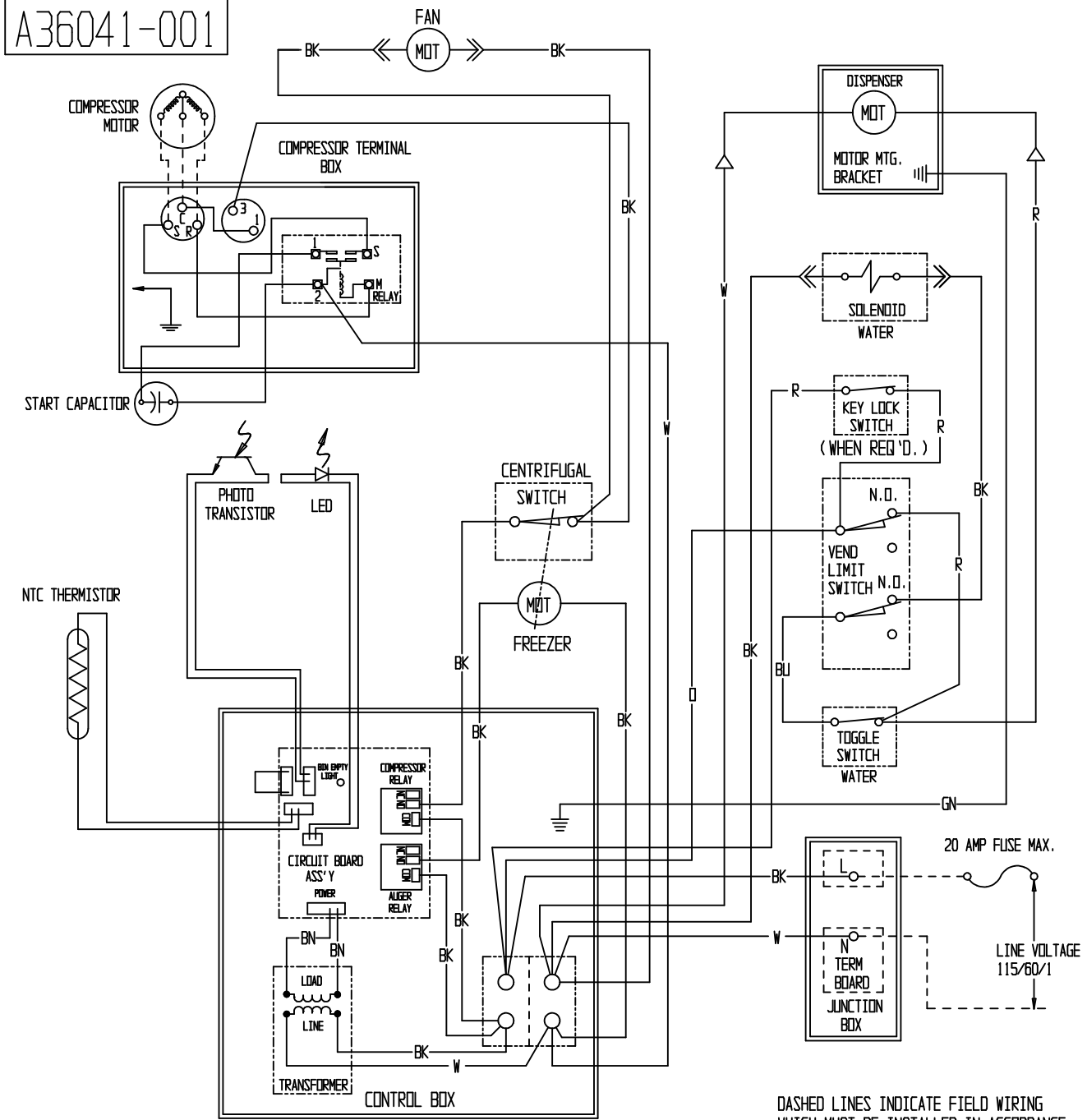

DASHED LINES INDICATE FIELD WIRING WHICH MUST BE INSTALLED IN ACCORDANCE WITH THE NATIONAL ELECTRICAL CODE AND ALL STATE AND LOCAL CODES

THIS UNIT MUST BE GROUNDED

USE COPPER CONDUCTORS ONLY

# FDE470 Service Parts Schematic Diagram FDE470AE-1A

CONTROLS SHOWN IN THE ICE MAKING  
MODE WITH ALL DISPENSING SYSTEMS  
IN OPERATON

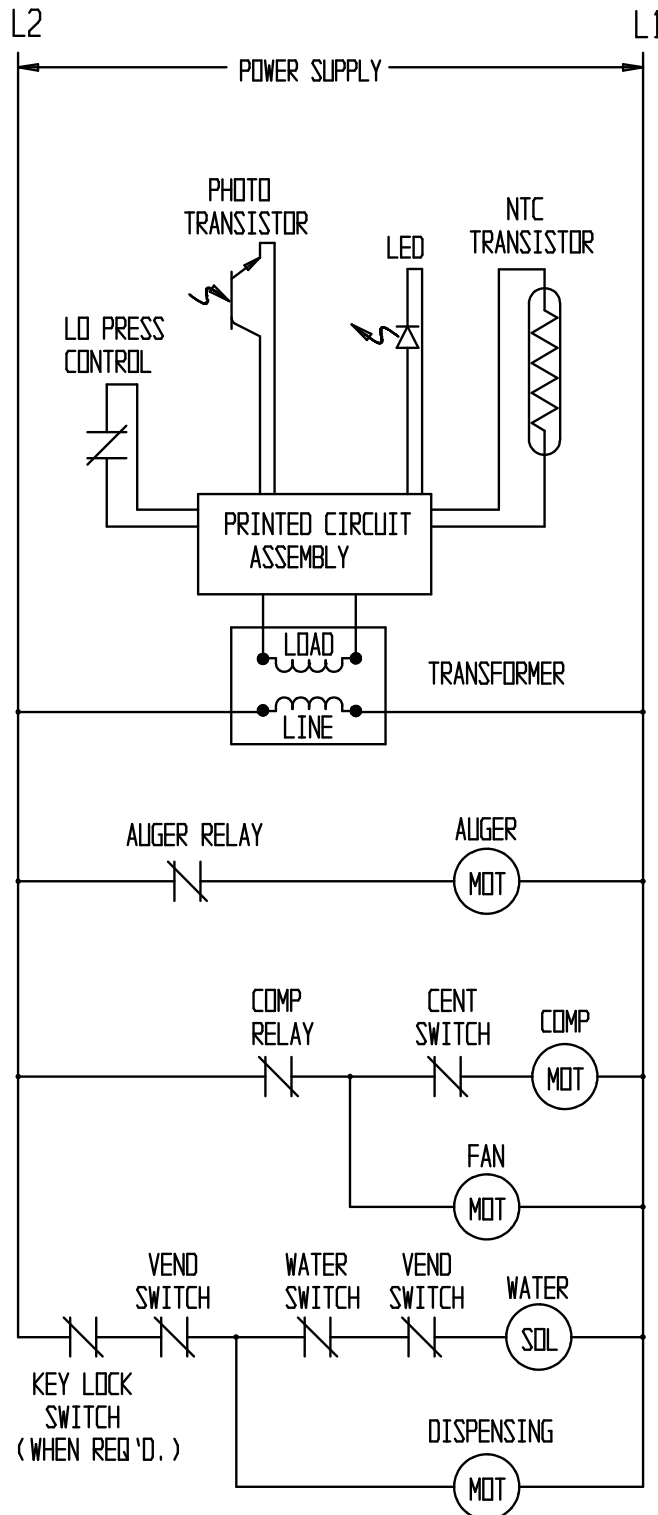

# FDE470 Service Parts

## Wiring Diagram FDE470AE-6A

A36041-006

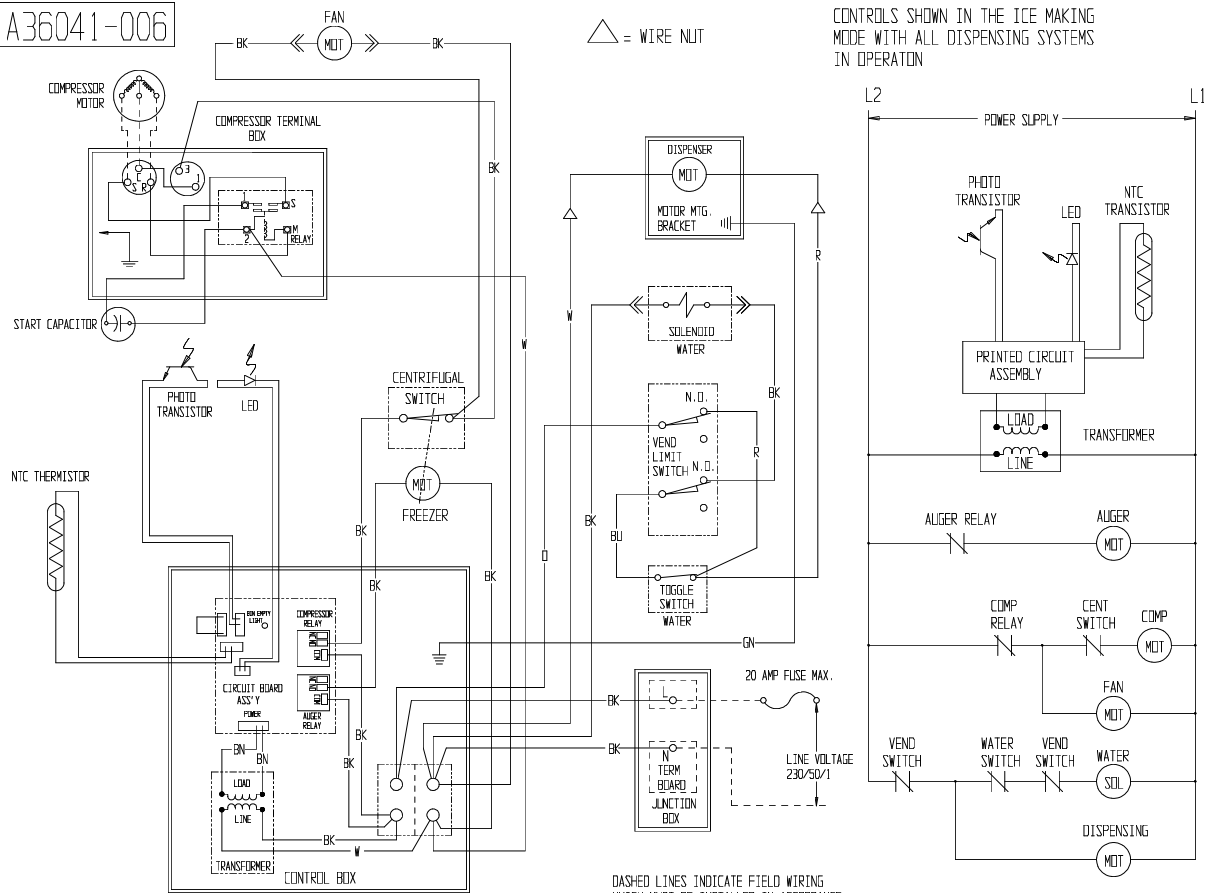

△ = WIRE NUT

CONTROLS SHOWN IN THE ICE MAKING MODE WITH ALL DISPENSING SYSTEMS IN OPERATION

THIS UNIT MUST BE GROUNDED

USE COPPER CONDUCTORS ONLY

DASHED LINES INDICATE FIELD WIRING WHICH MUST BE INSTALLED IN ACCORDANCE WITH THE NATIONAL ELECTRICAL CODE AND ALL STATE AND LOCAL CODES