

FM1500 SERVICE PARTS

This parts list contains the service parts and wiring diagrams for this model. Check the model number of the machine needing the parts to be certain that this is the correct parts list.

TABLE OF CONTENTS

Cabinet and Panels	Page 2
Air Cooled Refrigeration	Page 3
Water Cooled Refrigeration.....	Page 4
Evaporator	Page 5
Control Box.....	Page 6
Gearmotor.....	Page 7
Reservoir, Ice Chute.....	Page 8
Wiring Diagrams	Page 9

FM1500 SERVICE PARTS

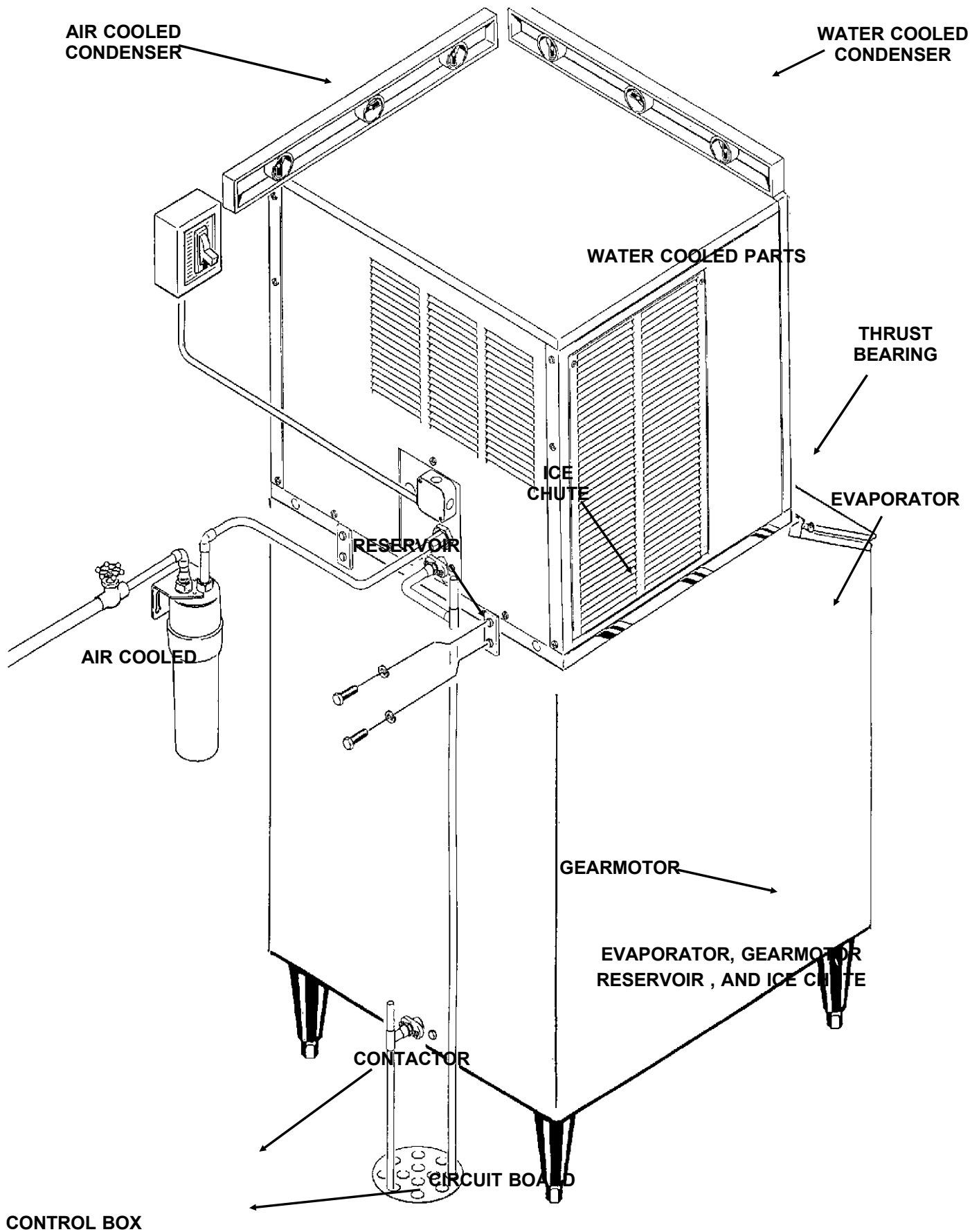

FM1500 SERVICE PARTS PANELS

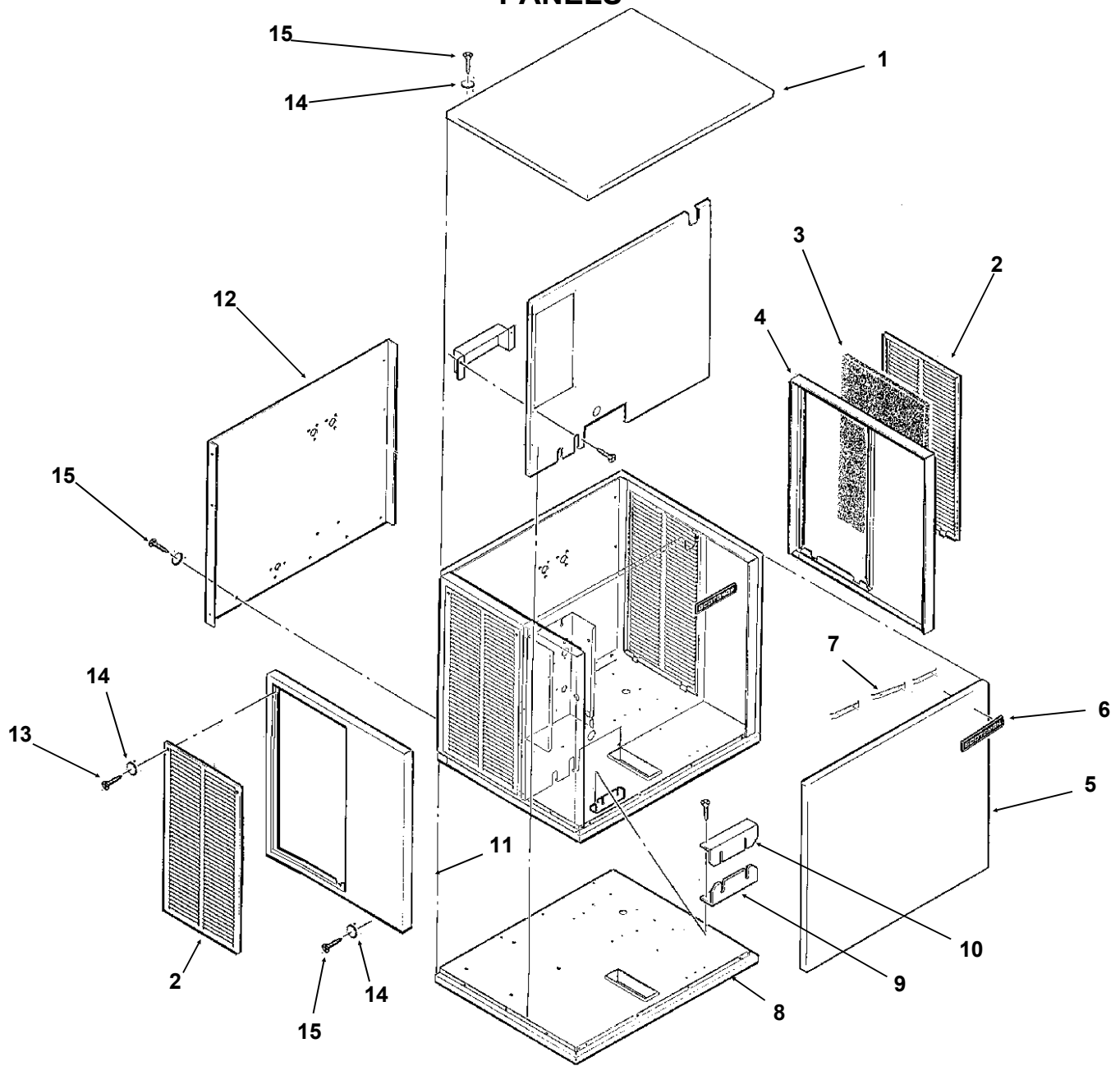

ITEM NUMBER	PART NUMBER	DESCRIPTION	ITEM NUMBER	PART NUMBER	DESCRIPTION
1.	A32159-001	Top Panel Painted	8.	A32542-001	Base Assembly
	A32159-002	Top Panel Stainless	9.	A31462-001	Tube Bracket
2.	A32161-001	Service Panel Paint	10.	A31461-001	Tube Bracket
	A32161-002	Service Panel S.S.	11.	A32163-001	Left End Panel Pt.
3.	A32975-001	Filter		A32163-002	Left End Panel S.S.
4.	A32162-001	Right End Panel Pt.	12.	A32202-003	Back Panel
	A32162-002	Right End Panel S.S.	13.	03-1404-12	Screw
5.	A32160-001	Front Panel Painted	14.	03-1417-03	Washer
	A32160-002	Front Panel S.S.	15.	03-1531-01	Screw
6.	15-0711-01	Emblem			
7.	03-0271-00	Clip For Emblem (3)			

FM1500 SERVICE PARTS AIR COOLED REFRIGERATION

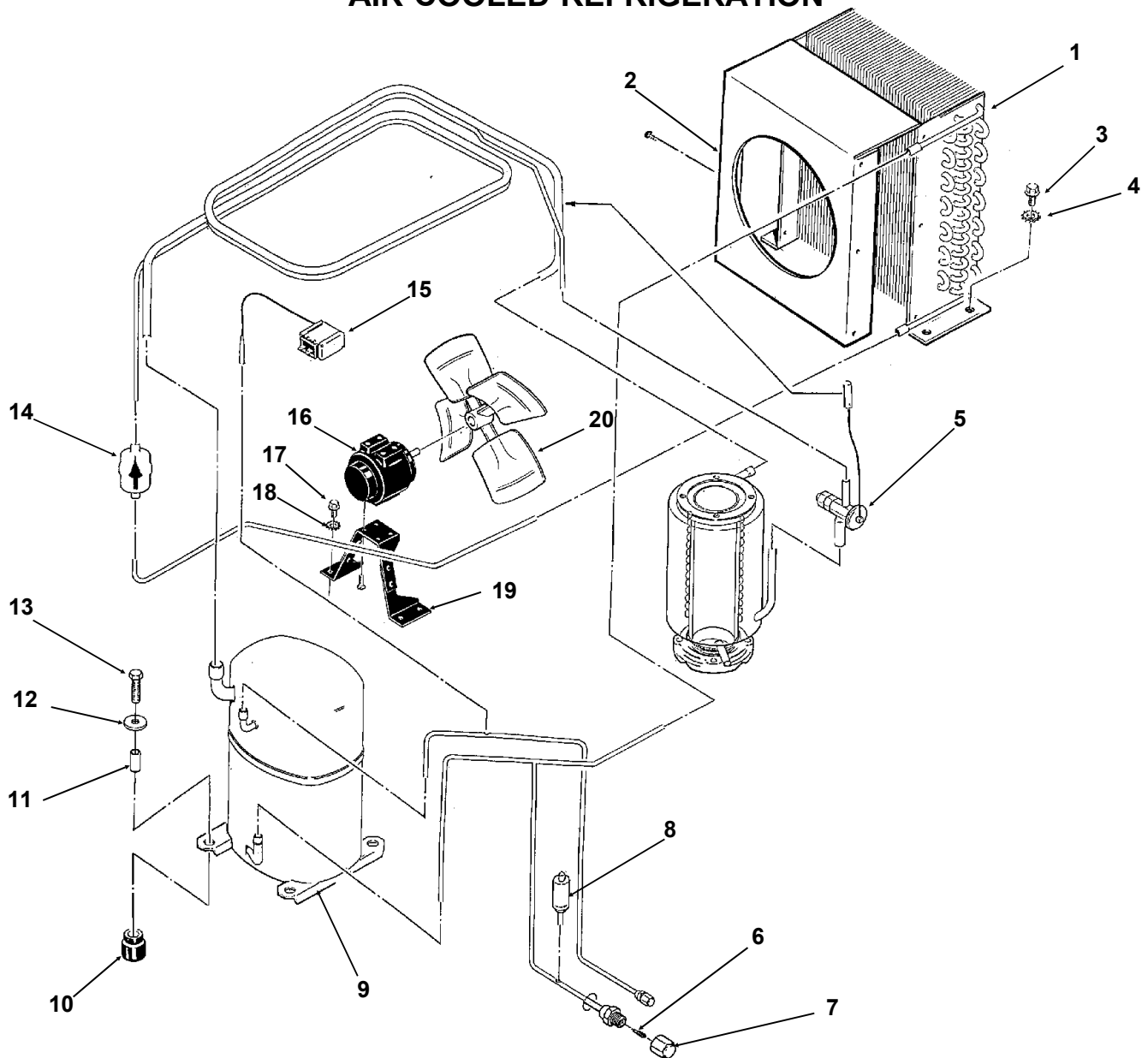

ITEM NUMBER	PART NUMBER	DESCRIPTION	ITEM NUMBER	PART NUMBER	DESCRIPTION
1.	18-3709-01	Air Cooled Condens.	10.	18-6800-01	Grommet
2.	A32170-001	Shroud	11.	18-2300-26	Sleeve
3.	03-1645-01	Bolt	12.	03-1407-07	Washer
4.	03-1417-09	Washer	13.	03-1405-20	Bolt
5.	16-0780-21	Expansion Valve	14.	02-3319-02	Drier
6.	16-0560-00	Valve Core	15.	11-0447-20	L. P. Control
7.	16-0563-00	Valve Cap	16.	18-5105-02	Fan Motor
8.	11-0446-21	Pressure Control	17.	03-1404-03	Screw
9.	18-5900-02	Compressor	18.	03-1417-09	Washer
	208-230/60/1		19.	18-3739-0-1	Fan Motor Bracket
	18-5900-03	Compressor	20.	18-3732-01	Fan Blade
	208-230/60/3				

FM1500 SERVICE PARTS WATER COOLED REFRIGERATION

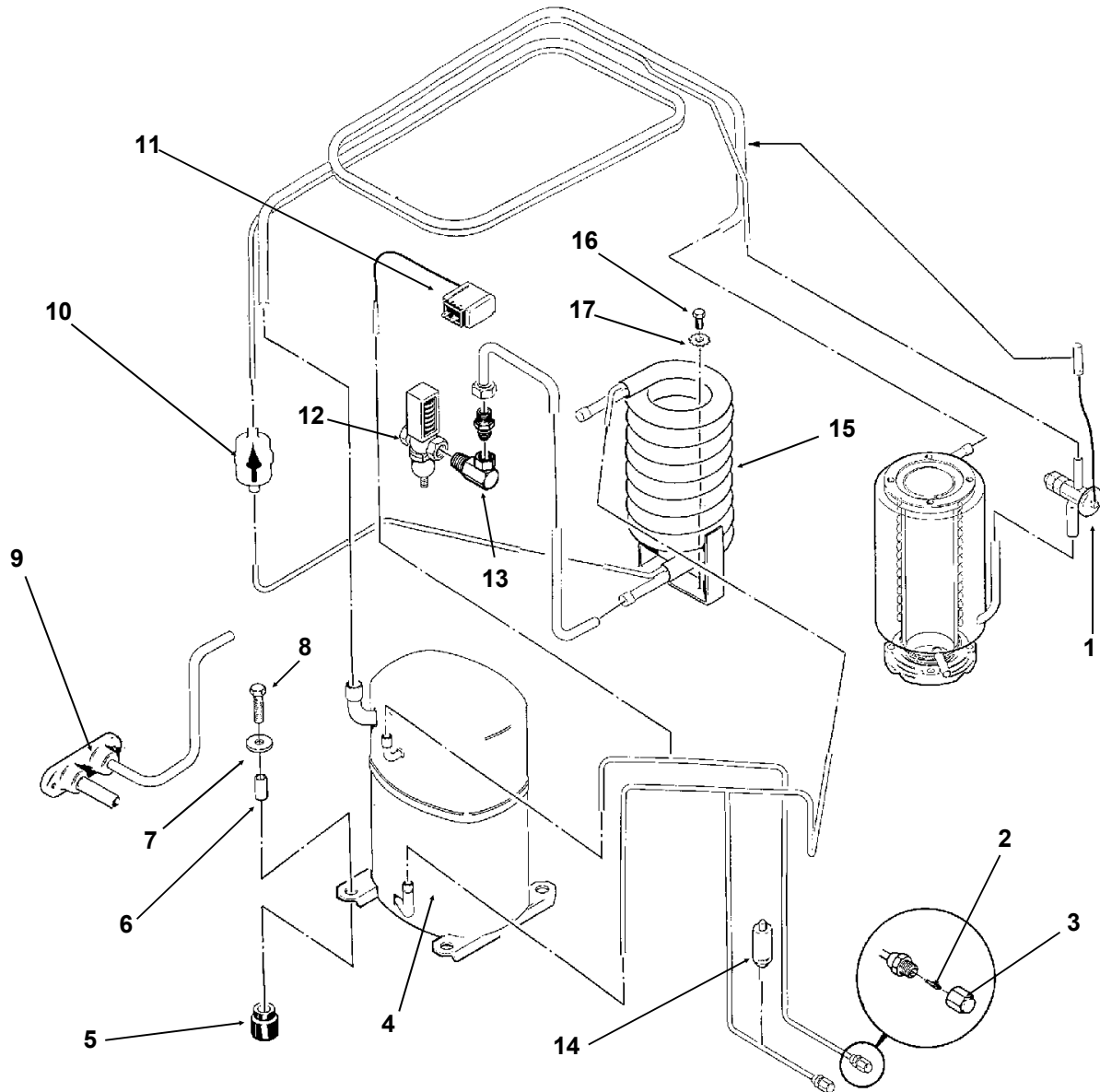

ITEM NUMBER	PART NUMBER	DESCRIPTION	ITEM NUMBER	PART NUMBER	DESCRIPTION
1.	16-0780-21	Expansion Valve	8.	03-1405-20	Bolt
2.	16-0560-00	Valve Core	9.	A31878-004	Drain
3.	16-0563-00	Valve Cap	10.	02-3319-02	Drier
4.	18-5900-03	Compressor	11.	11-0447-20	Lo Press. Control
	18-5900-02	Compressor	12.	11-0424-01	Water Reg. Valve
		208-230/60/3	13.	16-0401-02	Elbow
		208-230/60/1	14.	11-0446-21	Pressure Control
5.	18-6800-01	Grommet	15.	18-6900-25	Water Cooled Condenser
6.	18-2300-26	Sleeve	16.	03-1645-01	Screw
7.	03-1407-07	Washer	17.	03-1417-09	Washer

FM1500 SERVICE PARTS EVAPORATOR

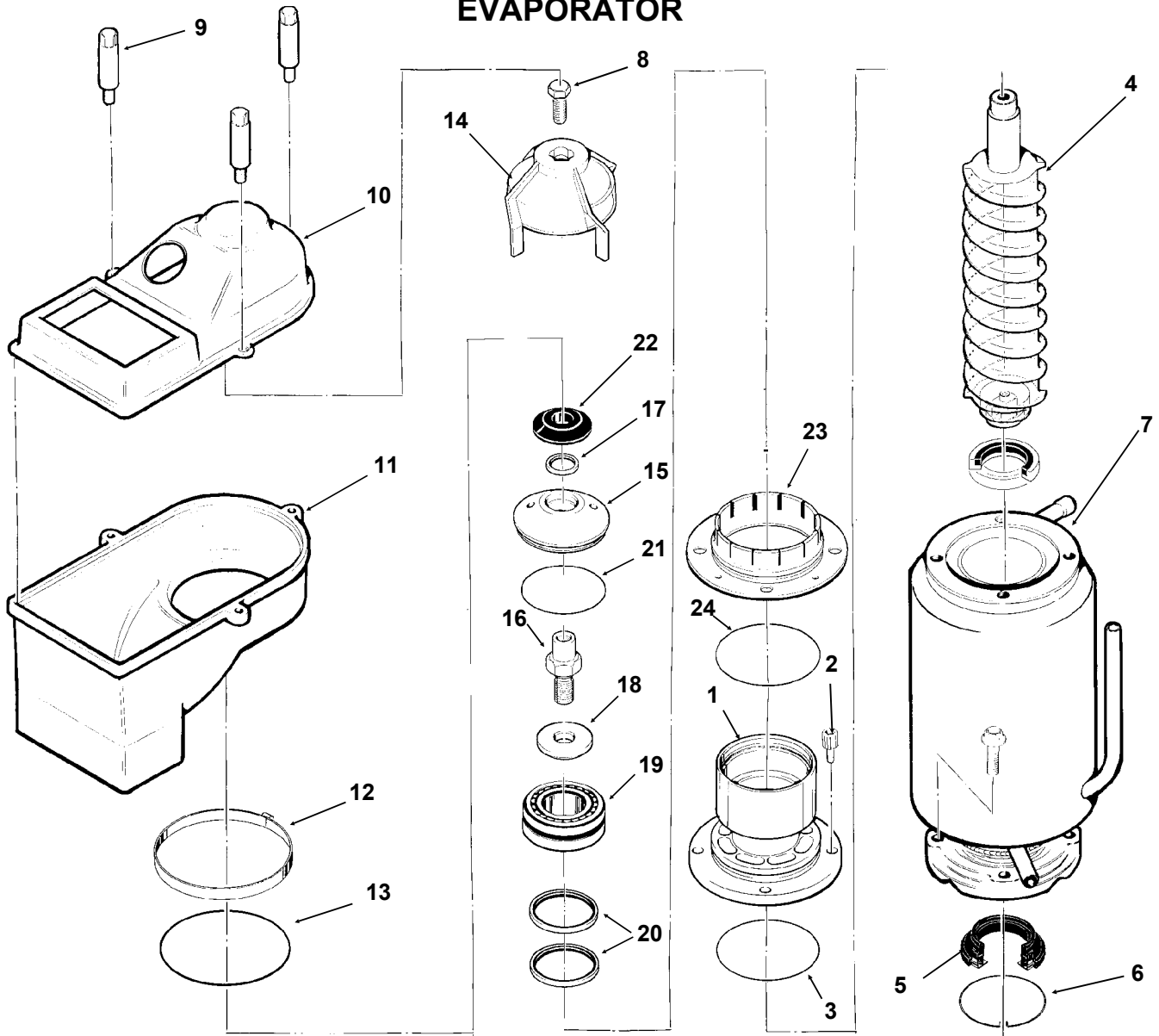

ITEM NUMBER	PART NUMBER	DESCRIPTION	ITEM NUMBER	PART NUMBER	DESCRIPTION
1.	A34505-020	Divider Includes Items 19 & 20	11.	02-2926-01	Ice Chute Body
2.	03-1544-08	Soc. head Screw	12.	A32905-001	Clamp
3.	13-0617-45	O-ring	13.	13-0617-52	O-ring
4.	A38071-022	Auger	14.	02-3001-01	Ice Sweep
5.	02-0929-03	Water Seal	15.	02-3128-20	Breaker Cover
6.	A32777-001	Ring, Water Seal	16.	08-0660-01	Auger Stud
7.	A32890-020	Evaporator	17.	02-2978-01	Lip Seal
8.	03-1405-52	Hex Cap Screw	18.	part of item 16	Thrust Washer
9.	02-2933-01	Hex stud	19.	A34559-020	Bearing
10.	02-2930-01	Ice Chute Cover	20.	02-2977-01	Lip Seal
			21.	13-0617-54	O-Ring
			22.	13-0871-01	Water Shed
			23.	02-2916-01	Slotted Collar
			24.	13-0617-49	O-Ring

Note: Evaporator is not available with internal parts. The auger and water seal must be ordered separately.

FM1500 SERVICE PARTS CONTROL BOX

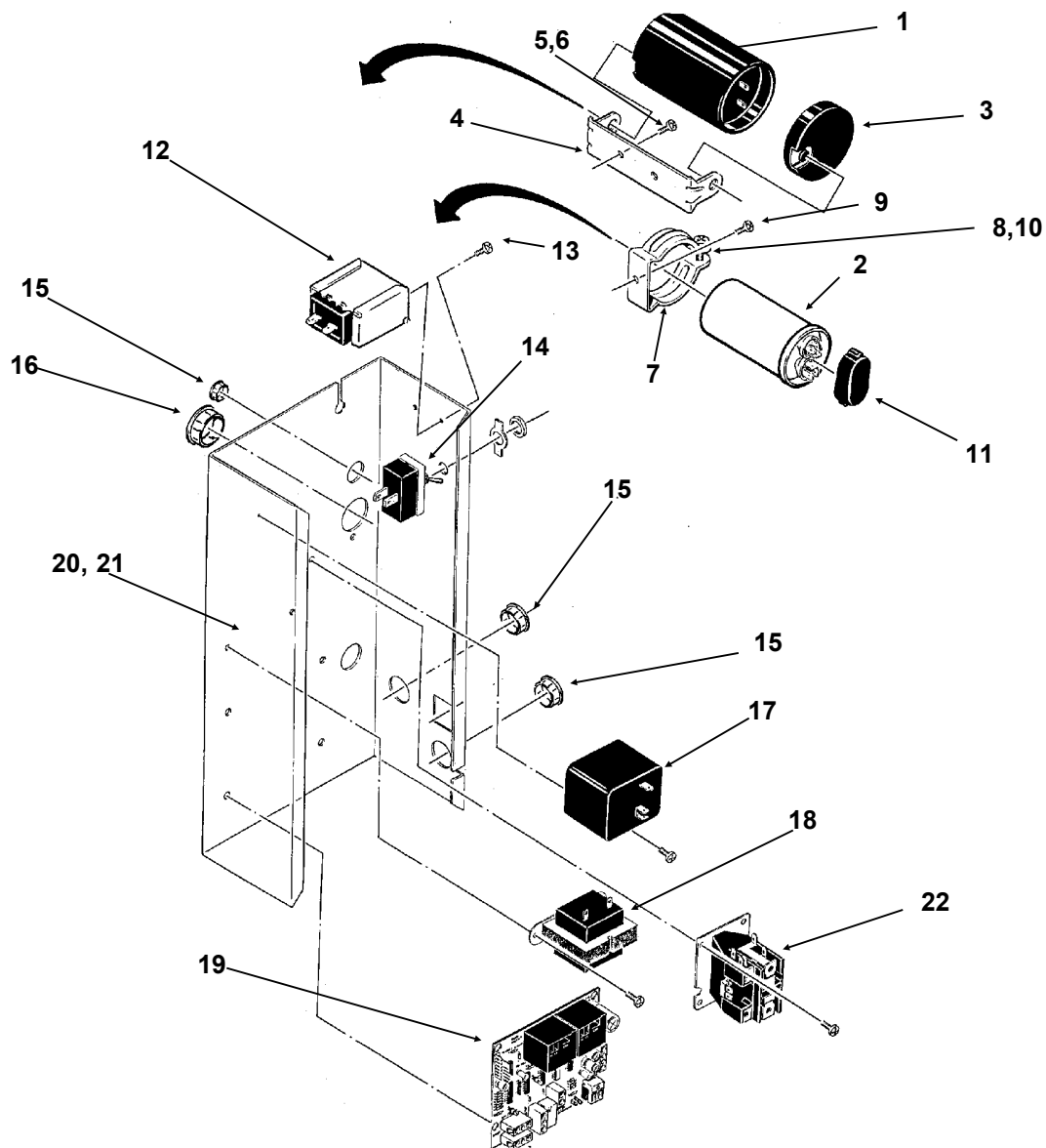

ITEM NUMBER	PART NUMBER	DESCRIPTION	ITEM NUMBER	PART NUMBER	DESCRIPTION
1.	18-1901-48	Start Capacitor	15.	12-1213-10	Snap Bushing
2.	18-1902-53	Run Capacitor	16.	12-1213-11	Snap Bushing
3.	18-4300-50	Start Capacitor Cap	17.	18-1903-46	Relay
4.	18-2200-39	Start Cap. Bracket	18.	12-2285-22	Transformer
5.	03-1638-04	Screw	19.	A37750-021	Circuit Board
6.	03-1417-15	Lockwasher	20.	No Number	Control Box
7.	A32872-001	Run Cap. Bracket	21.	A32896-001	Cont. Box Cover
8.	03-1652-02	Bolt	22.	12-2469-02	1 Phase Contactor
9.	03-1638-03	Screw		12-0739-02	3 Phase Contactor
10.	03-0255-04	Wing Nut	NOT ILLUSTRATED:		
11.	13-0666-00	Terminal Cover	23.	12-2337-02	3 Pin Plug Assy (safety circuit to circuit board)
12.	11-0447-20	Low Press. Control	24.	12-2340-01	4 Pin Plug Assy (transformer to circuit board)
13.	03-1403-02	Screw			
14.	12-0426-01	Master Switch			

FM1500 SERVICE PARTS GEARMOTOR

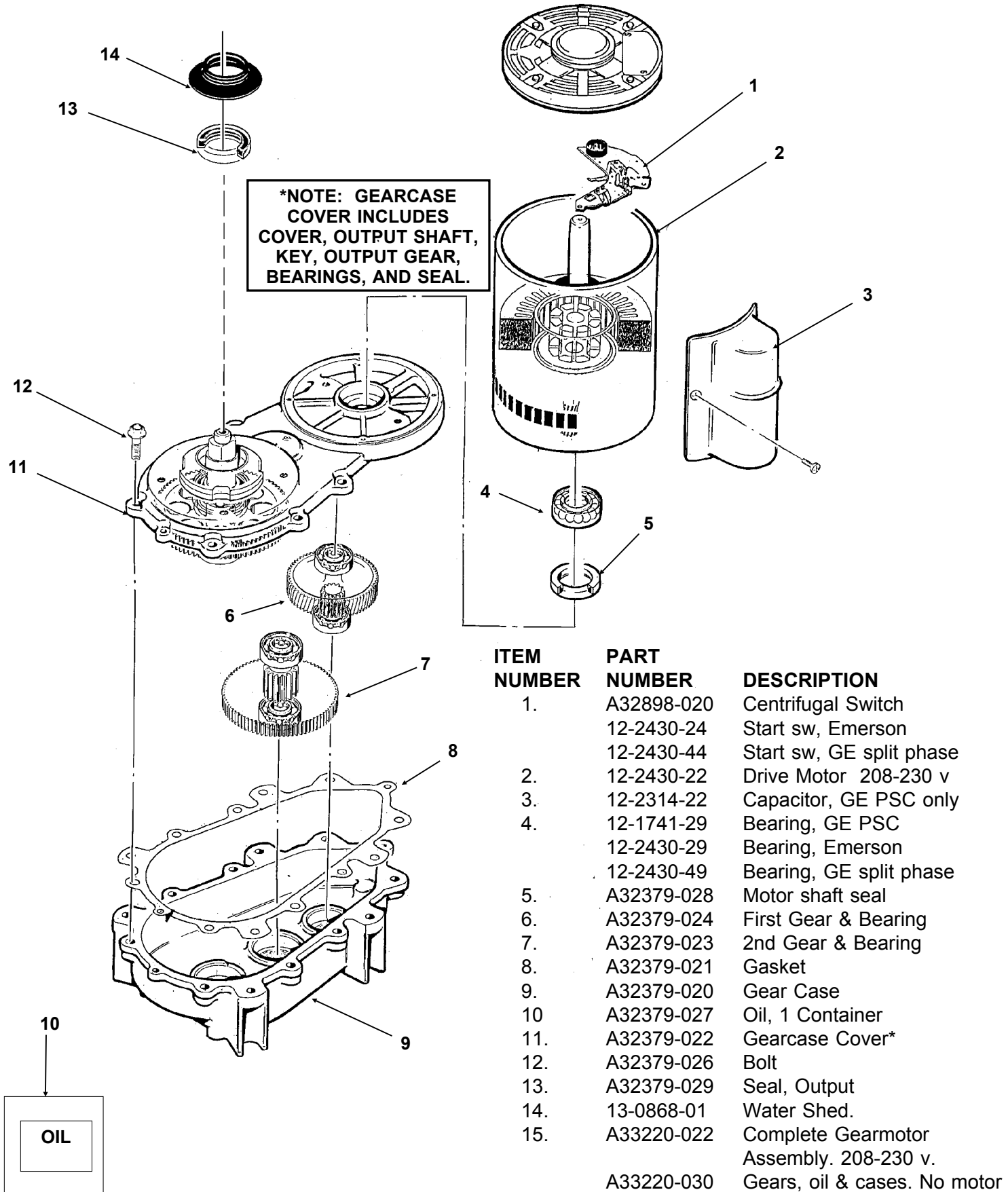

FM1500 SERVICE PARTS

RESERVOIR, DRAINS, ICE CHUTE, ICE LEVEL SENSORS

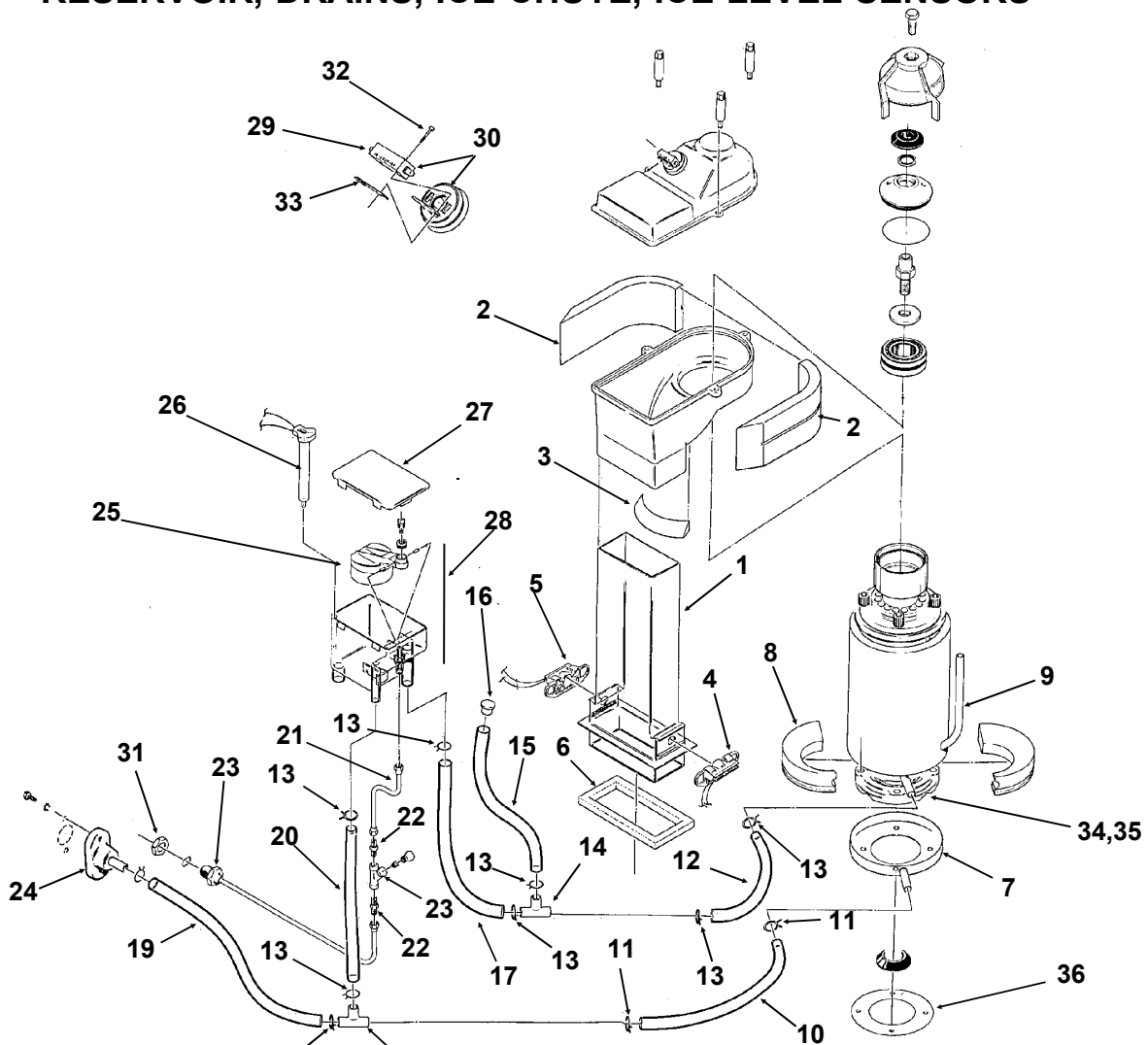

ITEM NUMBER	PART NUMBER	DESCRIPTION	ITEM NUMBER	PART NUMBER	DESCRIPTION
1.	02-2929-01	Ice Chute Lower	19.	13-0079-03	Tube, 18" Order By Ft.
2.	A32963-001	Insulation Collar Top	20.	13-0079-03	Tube, 11" Order By Ft.
3.	A33102-001	Insulation Collar Inside	21.	A32748-001	Tube
4.	A35419-020	Strap kit	22.	16-0791-01	Coupling Union
	A37708-021	LED & Phototransistor Assy. (set - includes item 5)	23.	A32878-001	Inlet Water Tube
5.	no number	same as item 4.	24.	A32282-004	Drain - Air Cooled
6.	A32930-001	Chute Gasket		A31878-004	Drain - Water Cooled
7.	A32050-001	Drip Pan	25.	A32922-020	Float Assy With Pin, Housing Seal, Rubber Seal, Insert & Float.
8.	A32962-001	Insulation Collar Bottom	26.	A33101-021	Thermo Probe
9.	A32962-002	Insulation Collar Bottom	27.	02-2936-01	Reservoir Cover
10.	13-0079-03	Hose 3.3" Order By Ft.	28.	A32929-020	Float And Reservoir Complete
11.	02-0538-00	Hose Clamp	29.	12-2329-01	Switch
12.	A33203-001	Preformed Hose	30.	A32891-020	Switch Housing W/Switch
13.	02-2814-08	Hose Clamp	31.	03-1394-01	Pal Nut
14.	16-0670-01	Tee	32.	03-1403-09	Screw
15.	13-0674-06	Tube, 14" Order By Ft.	33.	03-0886-00	Speed Nut
16.	A33205-001	Plug	34.	03-1420-03	Stud, Evap to GM
17.	13-0674-06	Tube, 9" Order By Ft.	35.	03-1417-13	Lock washer
18.	16-0670-02	Tee	36.	13-0704-00	Drip pan gasket

FM1500 SERVICE PARTS

AIR AND WATER COOLED, 208-230/60/1

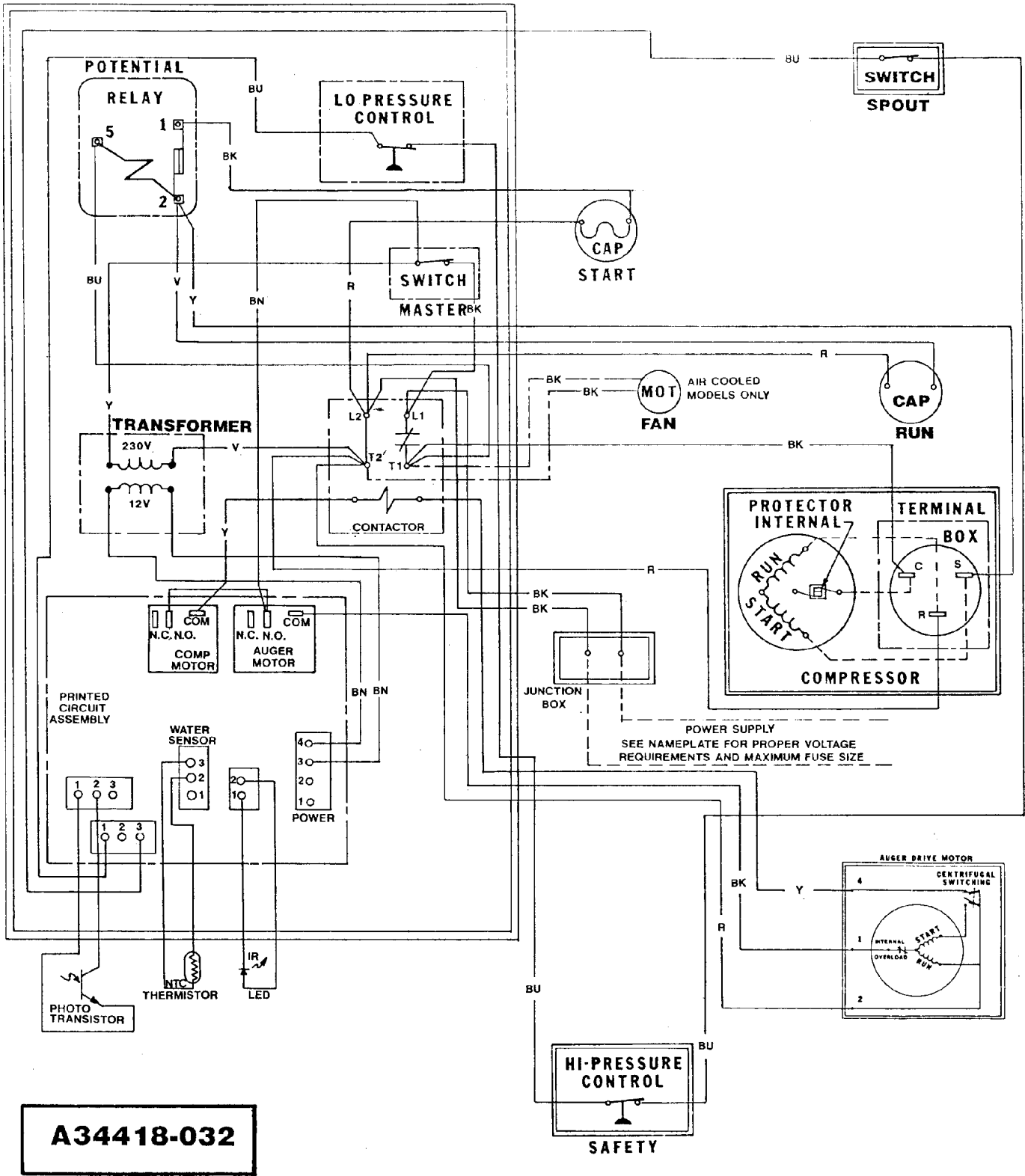

FM1500 SERVICE PARTS

AIR AND WATER COOLED, 208-230/60/1

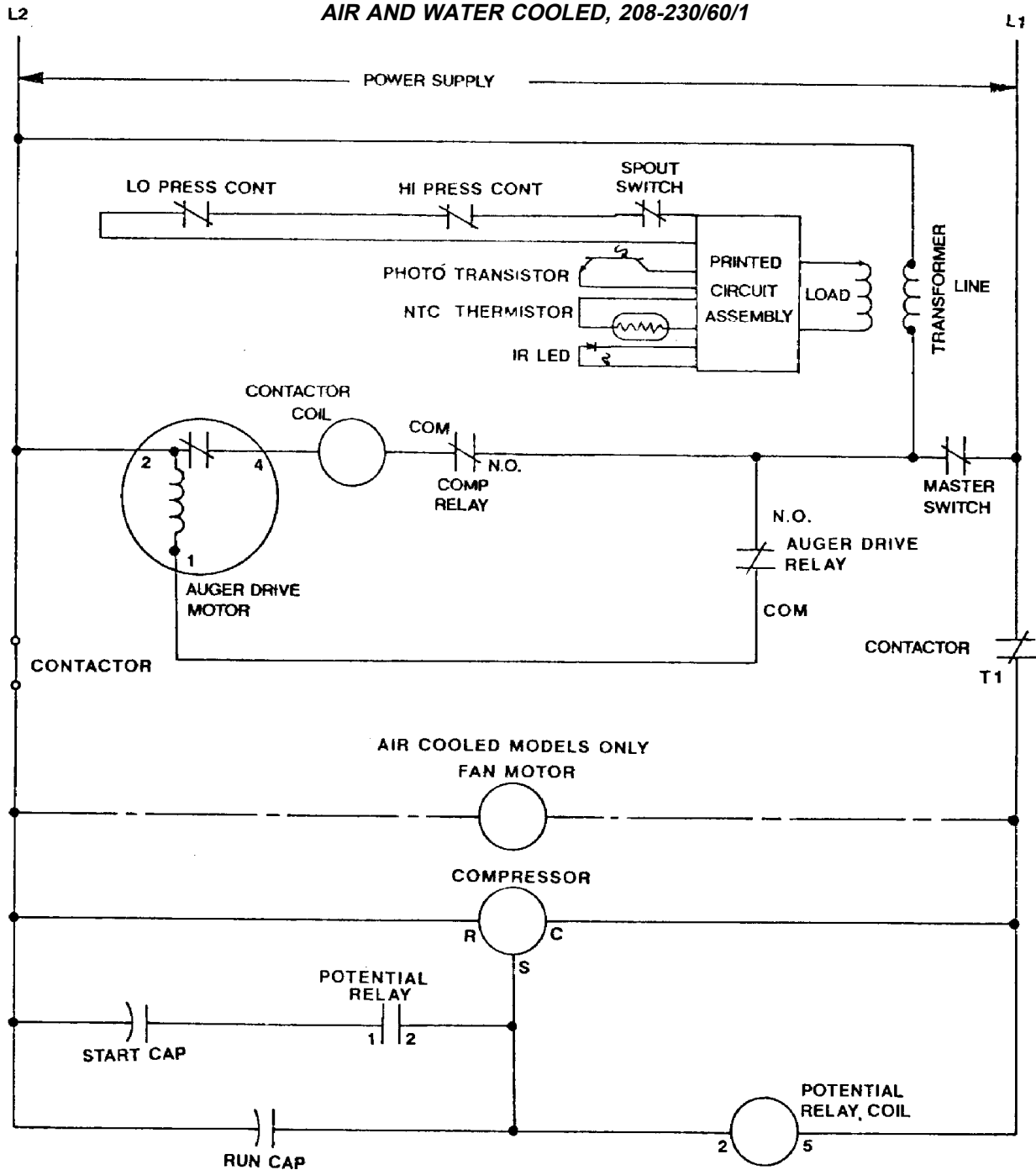

**USE COPPER CONDUCTORS ONLY
ALL CONTROLS SHOWN IN NORMAL ICEMAKING MODE
THIS UNIT MUST BE GROUNDED**

FM1500 SERVICE PARTS

AIR AND WATER COOLED, 208-230/60/3

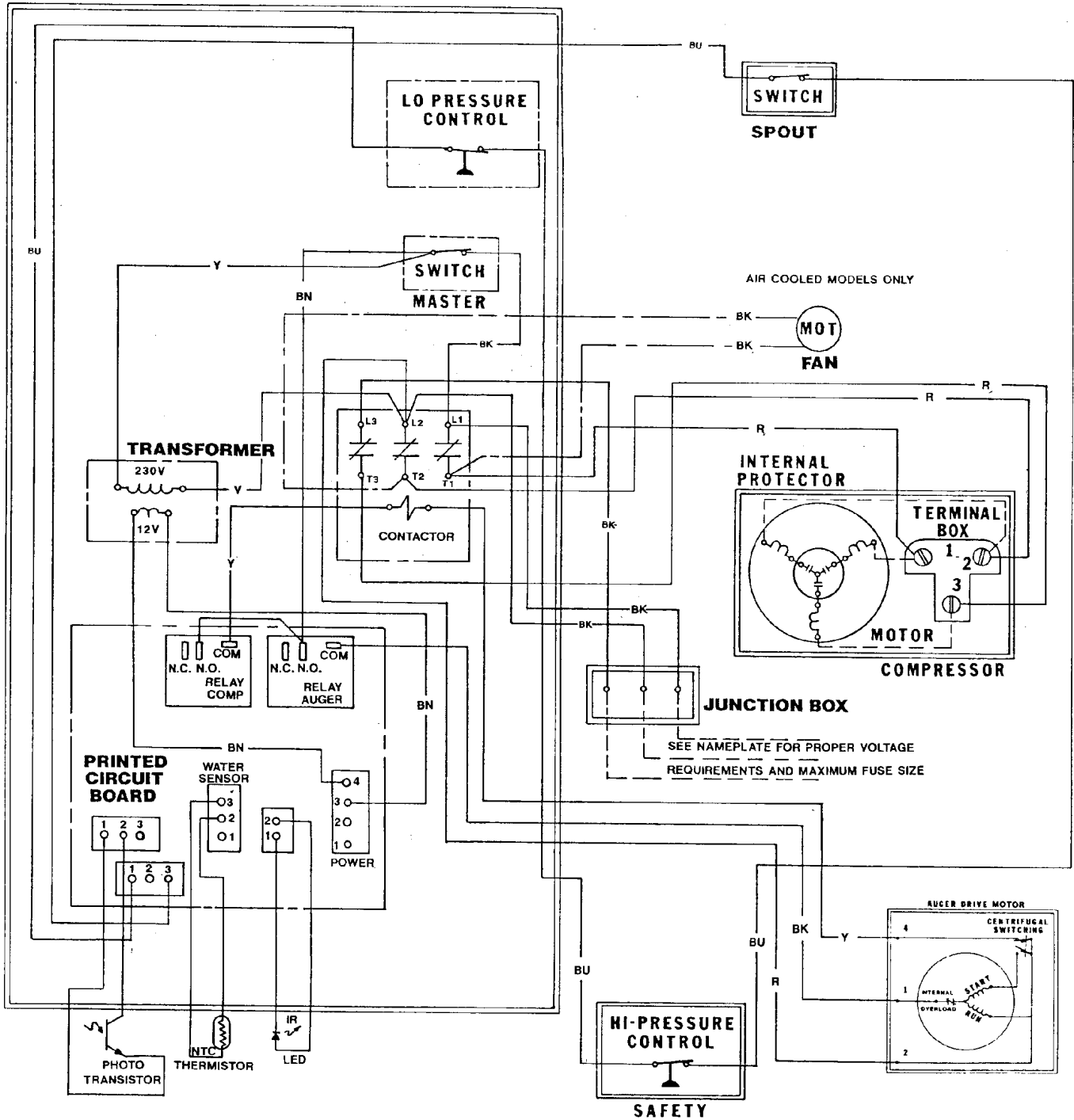

A34418-003

FM1500 SERVICE PARTS

AIR AND WATER COOLED, 208-230/60/3

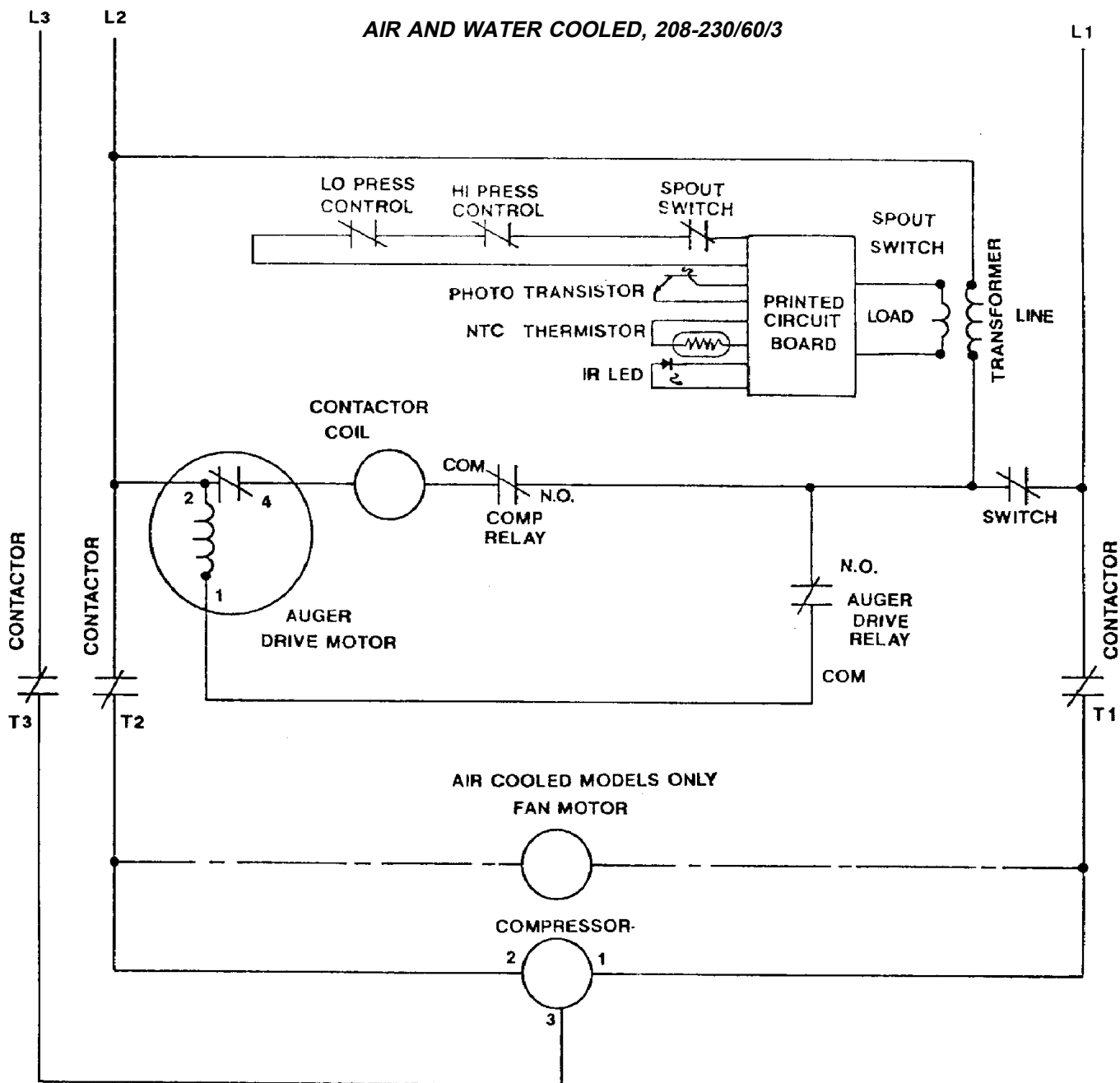

**USE COPPER CONDUCTORS ONLY
ALL CONTROLS SHOWN IN NORMAL ICEMAKING MODE
THIS UNIT MUST BE GROUNDED**