

# FM2400R SERVICE PARTS

This parts list contains the service parts and wiring diagrams for this model. Check the model number in question to be sure that it is applicable to this parts list.

## TABLE OF CONTENTS

Cabinet .....	2
Refrigeration .....	3
Water .....	4
Gearmotor.....	5
Evaporator .....	6
Control Box.....	7
Remote Condenser .....	8
Wiring Diagrams .....	9

# FM2400R SERVICE PARTS

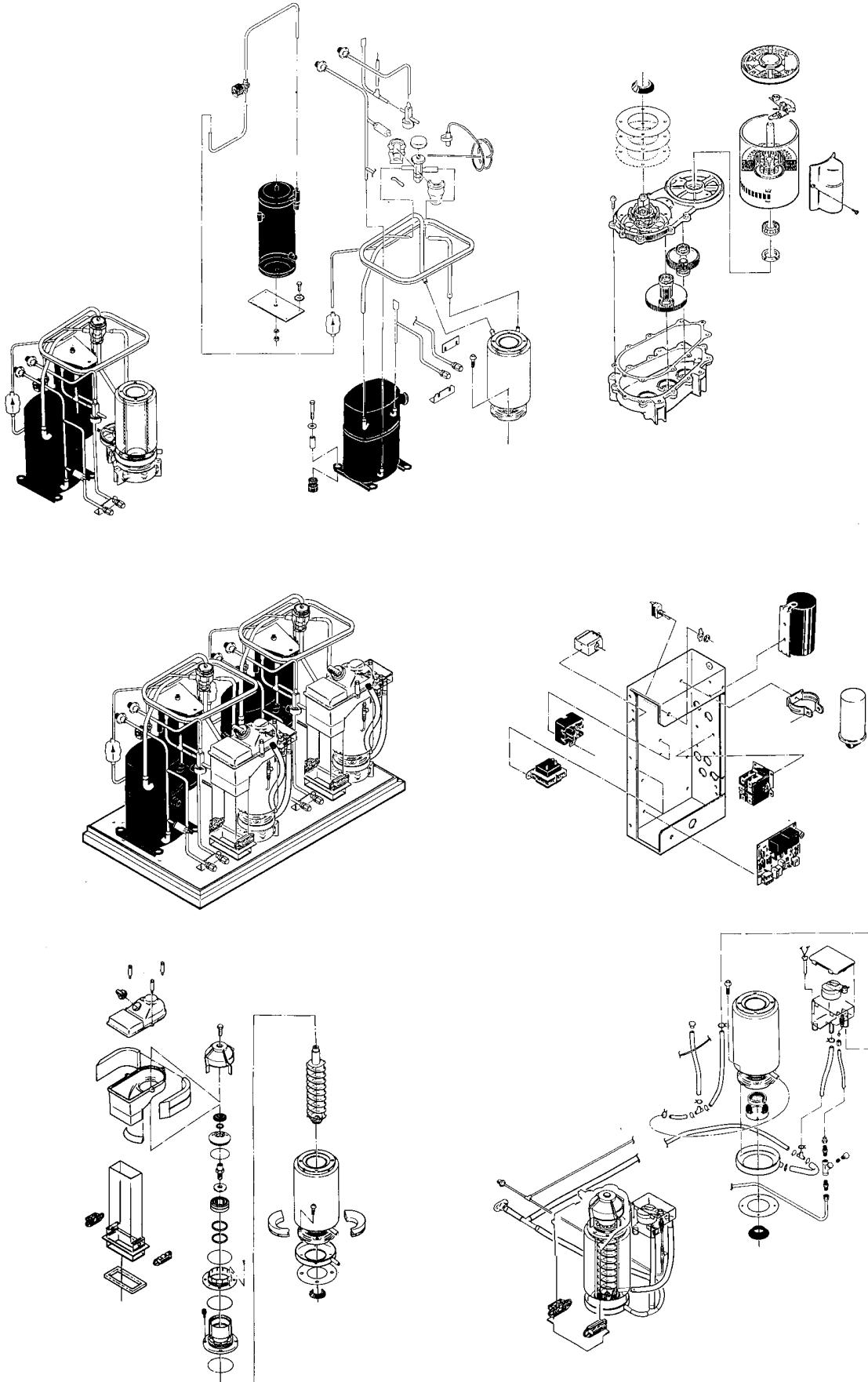

# FM2400R SERVICE PARTS

## Cabinet Assembly

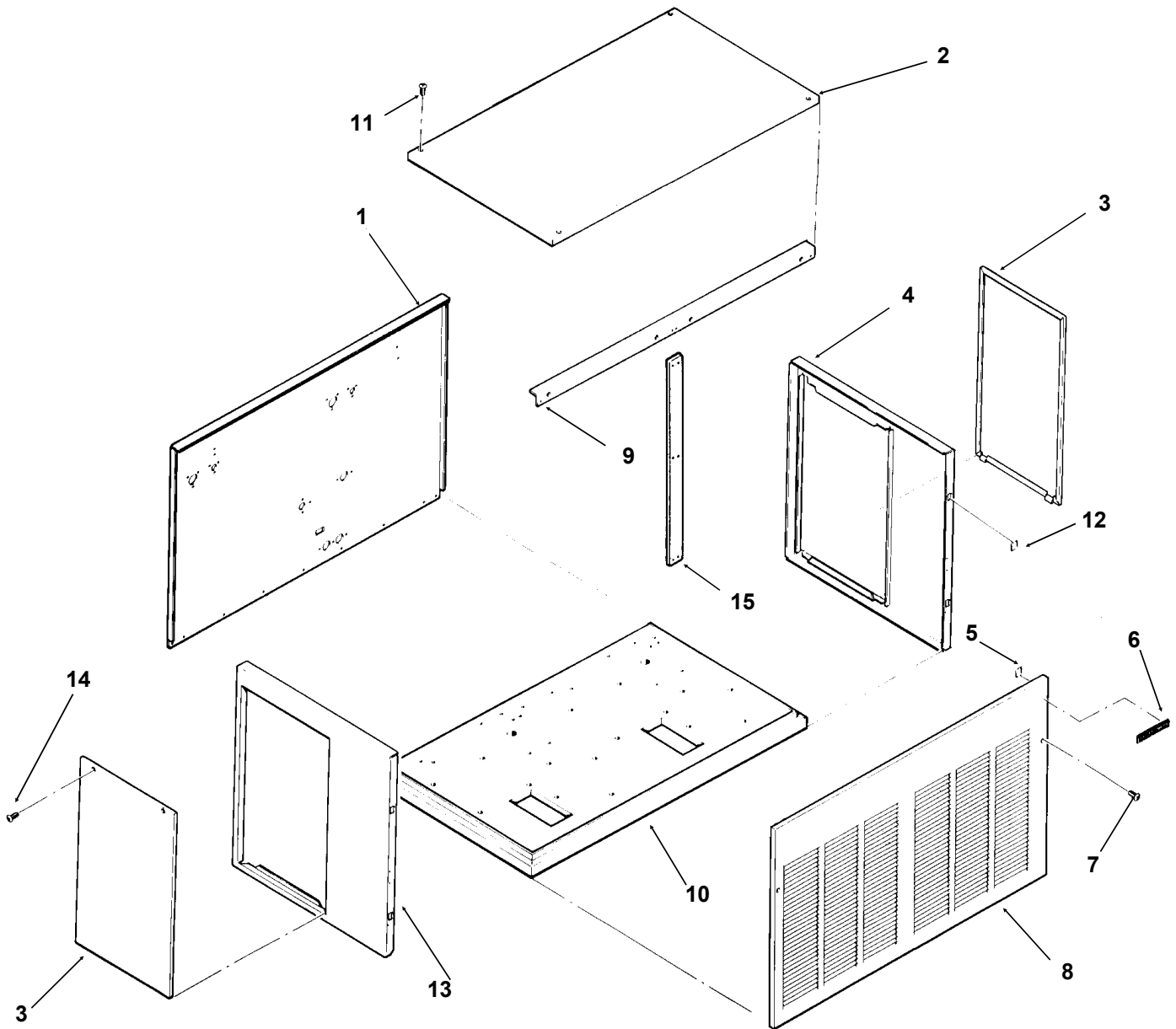

ITEM NUMBER	PART NUMBER	DESCRIPTION	ITEM NUMBER	PART NUMBER	DESCRIPTION
1	A34283-001	Back Panel, Painted	9	A34287-001	Support
2	A32461-001	Top Panel, Painted	10	A34282-001	Base
	A32461-002	Top Panel, S.S.	11	03-1531-01	Screw
3	A34038-001	Service Panel, Painted	12	02-0836-00	Catch
	A34038-002	Service Panel, S.S.	13	A32435-001	Left Side Panel, Painted
4	A33292-001	Right Side Panel, Painted		A32435-002	Left Side Panel, S.S.
	A33292-002	Right Side Panel, S.S.	14	03-1404-12	Screw
5	03-0271-00	Speed Clip	15.	A34286-001	Center Support
6	15-0711-01	Emblem			
7	03-1419-08	Screw			
8	A34294-001	Front Panel, Painted			
	A34294-002	Front Panel, S.S.			

# FM2400R SERVICE PARTS

## Refrigeration System

**NOTE: Compressors have internal overloads.**

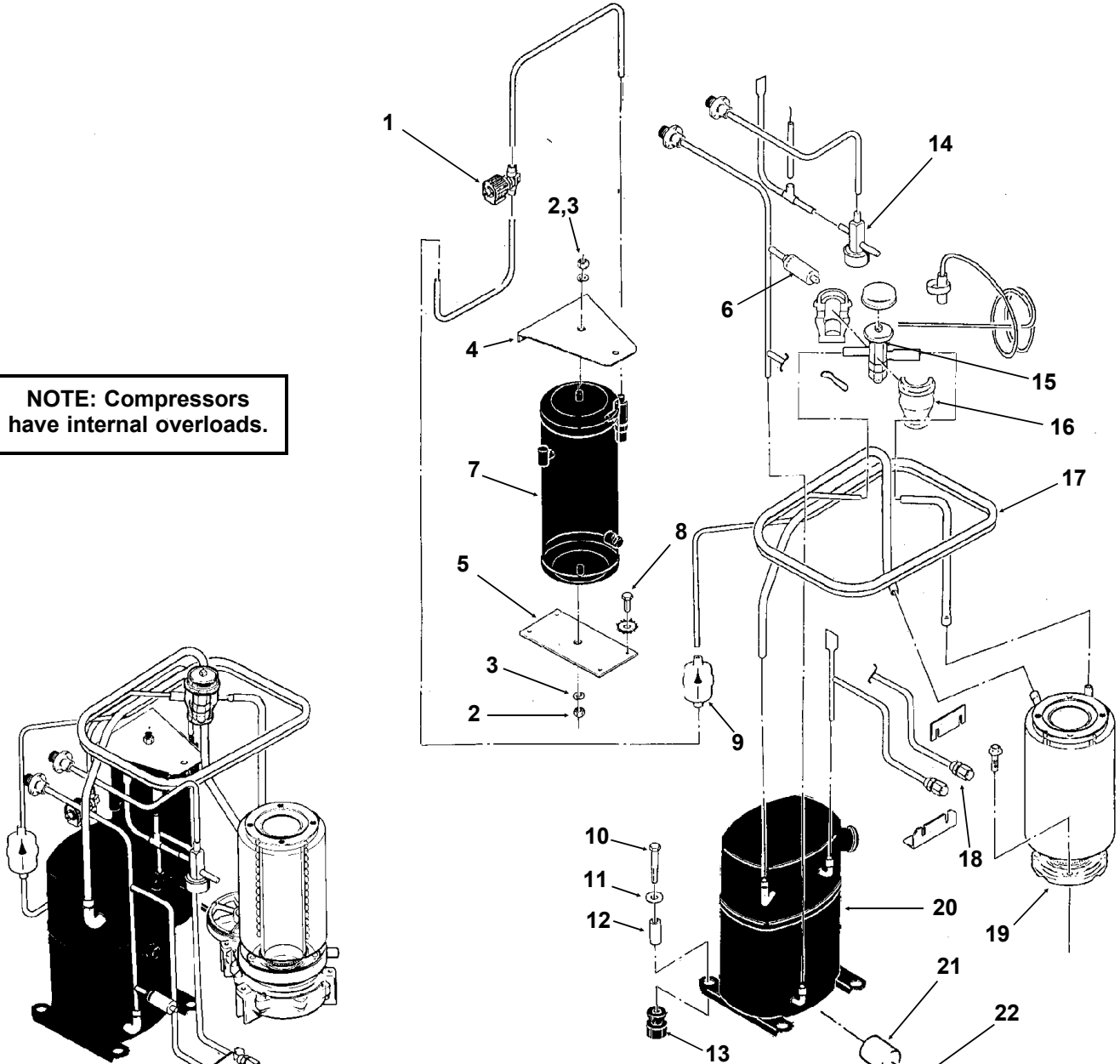

ITEM NUMBER	PART NUMBER	DESCRIPTION
1	12-2257-21	Liquid Line Valve
2	03-1406-13	Nut
3	03-1410-06	Washer
4	A32968-001	Receiver Brace
5	A31801-002	Receiver Mount
6	11-0446-23	Hi Pressure Cut Out
7	16-0761-01	Receiver
8	03-1645-01	Cap Screw
9	02-3319-02	Dryer
10	03-1405-20	Cap Screw
11	03-1407-07	Washer
12	18-2300-26	Sleeve

ITEM NUMBER	PART NUMBER	DESCRIPTION
13	18-6800-01	Rubber Grommet
14	11-0422-22	Head Pressure Valve
15	16-0780-21	Thermo Expansion Valve
16	A32961-020	Insulation Kit for TXV
17	A34050-001	Suction Line
18	16-0560-00	Core
	16-0563-00	Nut
19	A32890-020	Evaporator
20	18-8879-21	Compressor (1 Phase)
	18-8879-22	Compressor (3 Phase)
21	18-2308-01	Crankcase Heater
22	18-2309-01	Clip

# FM2400R SERVICE PARTS

## Water System, Water Seal

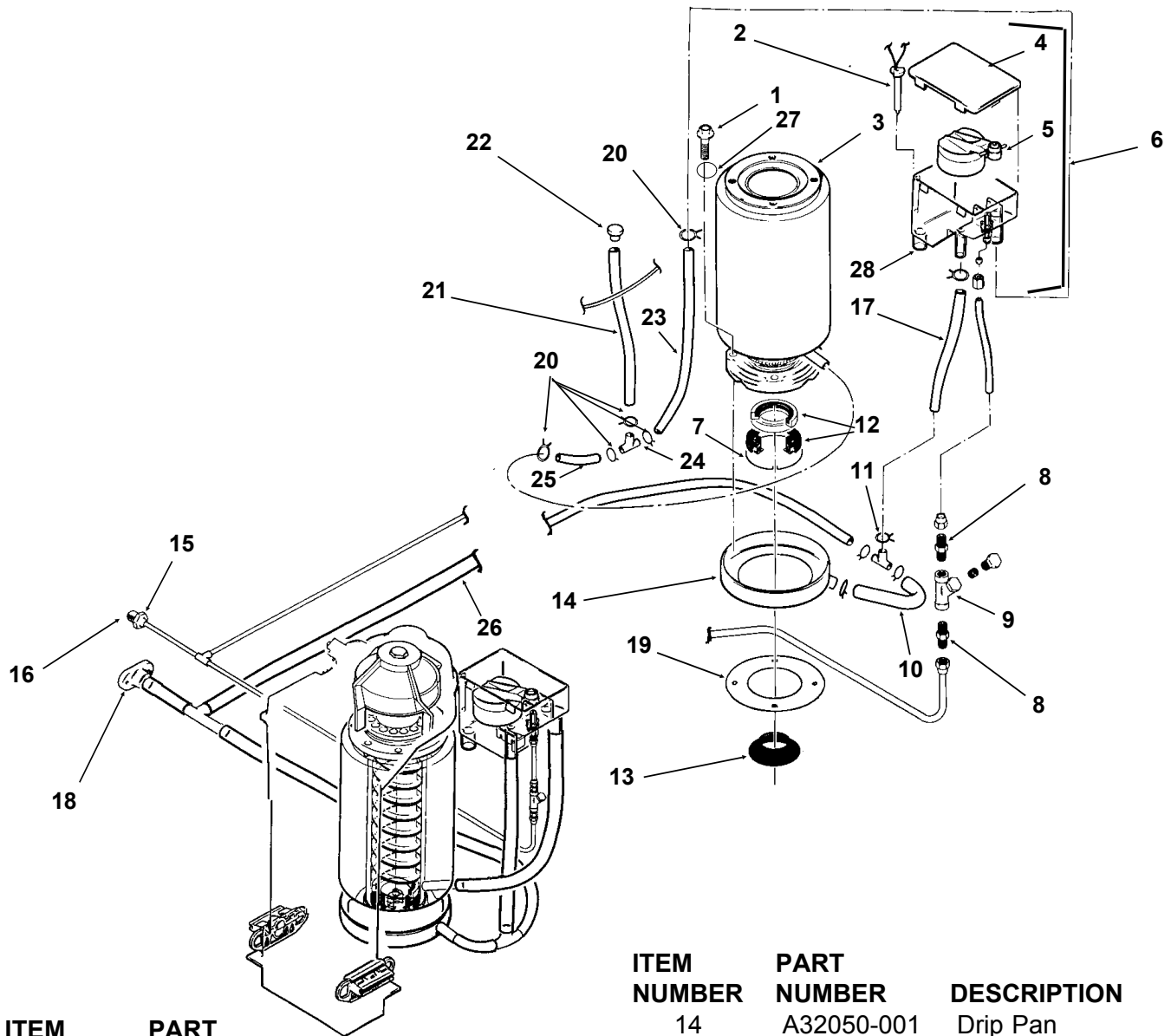

ITEM NUMBER	PART NUMBER	DESCRIPTION	ITEM NUMBER	PART NUMBER	DESCRIPTION
1	03-1420-03	Cap Screw	14	A32050-001	Drip Pan
2	A33101-022	Water Level Sensor	15	A27318-001	Water Inlet Fitting
3	A32890-020	Evaporator	16	03-1394-01	Pal Nut
4	02-2936-01	Res. Cover	17	13-0079-03	Res. Overflow, 8" req.
5	A32907-001	Float Assembly with pin, housing seal, rubber seal, insert & float	18	A3282-004	Drain Casting
6	A32929-020	Reservoir Assembly	19	13-0704-00	Gasket
7	A32777-001	Retaining Ring for Seal	20	02-2814-08	Clamps
8	16-0791-01	Half Union	21	13-0674-06	Evap. Drain, 14" req.
9	16-0162-00	Strainer	22	A33205-001	Plug
10	13-0079-03	Tube, 6.5" req.	23	13-0674-06	Evap. Inlet Tube, 5" req.
11	16-0670-02	Tee	24	16-0670-01	Tee
12	02-0929-23	Water Seal	25	A33203-001	Tube, Preformed
13	13-0868-01	Water Shed	26	13-0079-03	Drain Tube, 24" req.
			27	03-1417-13	Lockwasher
			28	13-0230-00	Rubber Cap
				02-2814-01	Clamp

# FM2400R SERVICE PARTS

## Gearmotor

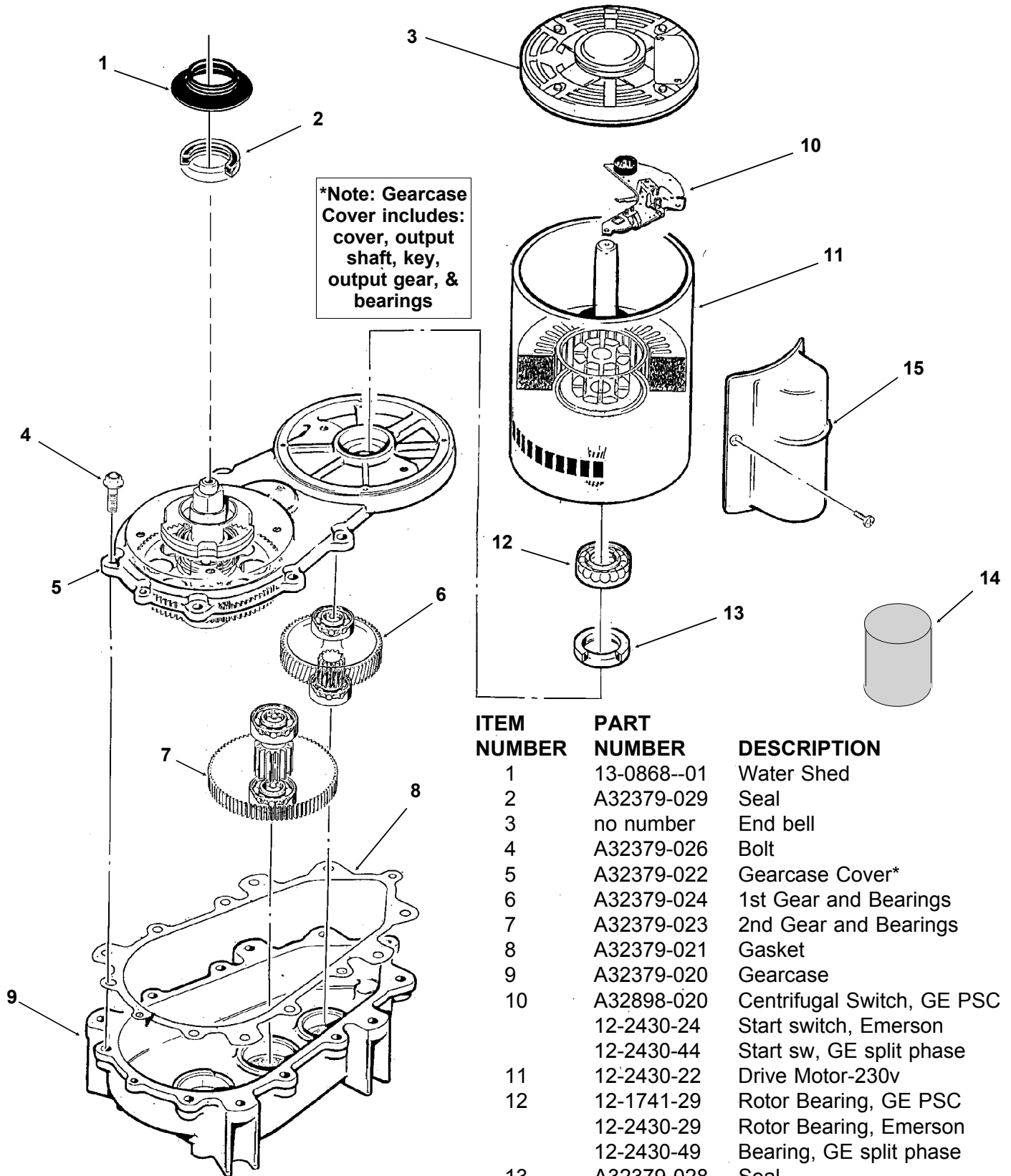

**\*Note: Gearcase Cover includes: cover, output shaft, key, output gear, & bearings**

ITEM NUMBER	PART NUMBER	DESCRIPTION
1	13-0868--01	Water Shed
2	A32379-029	Seal
3	no number	End bell
4	A32379-026	Bolt
5	A32379-022	Gearcase Cover*
6	A32379-024	1st Gear and Bearings
7	A32379-023	2nd Gear and Bearings
8	A32379-021	Gasket
9	A32379-020	Gearcase
10	A32898-020	Centrifugal Switch, GE PSC
	12-2430-24	Start switch, Emerson
	12-2430-44	Start sw, GE split phase
11	12-2430-22	Drive Motor-230v
12	12-1741-29	Rotor Bearing, GE PSC
	12-2430-29	Rotor Bearing, Emerson
	12-2430-49	Bearing, GE split phase
13	A32379-028	Seal
14	A32379-027	Oil, 1 Container
15	12-2314-22	Capacitor, GE PSC only
16	A33220-022	Complete Assembly 230v
	A33220-030	Gears, oil & cases. No motor.

# FM2400R SERVICE PARTS

## Evaporator, Bin Controls

Item 2: Manual reset switch is part number 12-2398-01.

To secure item 2:  
Use O-Ring, part number 13-0617-53.

### ITEM NUMBER

### PART NUMBER

### DESCRIPTION

1.	02-2933-01	Hex Stud	
2.	A32891-020	Housing & Switch	
3.	02-2930-01	Ice Chute Cover	
4.	A32963-001	Insulation Top (half)	
5.	02-2926-01	Ice Chute Body	
6.	A33102-001	Insulation Collar Inside	
	A35419-020	Strap Kit	
7.	02-2929-01	Ice Chute Lower	
8.	A37708-021	Bin Controls Assy. (set of 2)	
9.	A32930-001	Chute Gasket	
10.	03-1405-52	Hex Cap Screw	
11.	02-3001-01	Ice Sweep	
12.	13-0871-01	Water Shed	
13.	02-2978-01	Lip Seal	
14.	02-3128-20	Breaker Cover	
15.	13-0617-54	O-Ring	
16.	08-0660-01	Auger Stud	
17.	part of item 16	Thrust Washer	
18.	A34559-020	Bearing	
19.	02-2977-01	Lip Seal	
20.	03-1405-27	Screw	
		21.	13-0617-52 O-Ring
		22.	02-2916-01 Slotted Collar
		23.	13-0617-45 O-Ring
		24.	03-1544-08 Soc. Head Screw
		25.	A34505-020 Breaker (Divider) (includes 18 & 19)
		26.	A38071-022 Auger
		27.	A32890-020 Evaporator
		28.	03-1420-03 Cap Screw
		29.	A32962-001 Insulation Bot. (half)
		30.	A32050-001 Drip Pan
		31.	13-0704-00 Drip Pan Gasket
		32.	13-0868-01 Water Shed
		33.	13-0617-49 O-ring
		34.	03-1408-36 Washer
		35.	A34969-001 Bail clamp, not shown

# FM2400R SERVICE PARTS

## Control Box

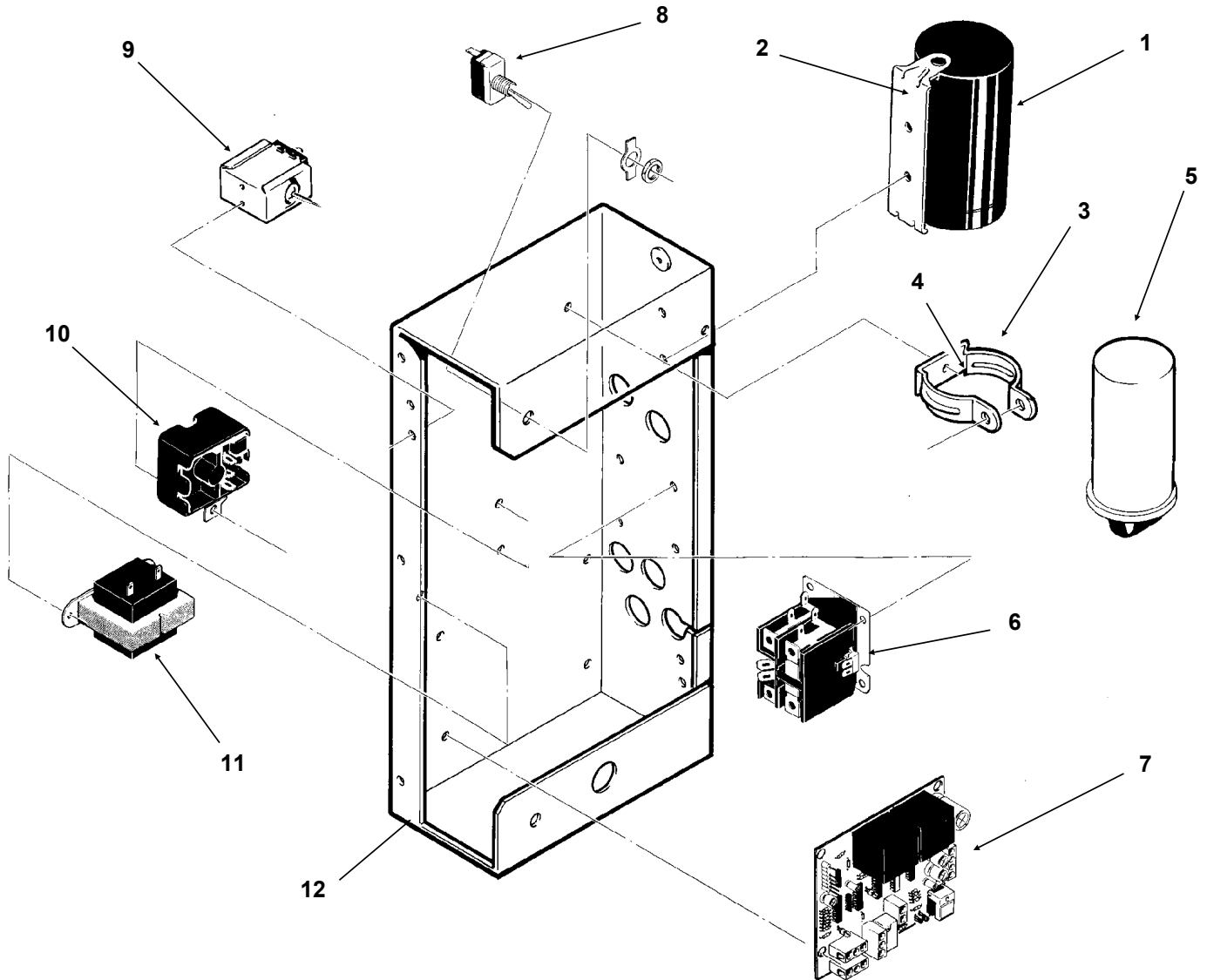

ITEM NUMBER	PART NUMBER	DESCRIPTION	ITEM NUMBER	PART NUMBER	DESCRIPTION
1	18-1901-48	Start Capacitor	7	A37750-021	Circuit Board
	18-4300-50	Start Capacitor Cap.	8.	12-0426-01	Master Switch
2.	18-2200-39	Start Capacitor Bracket	9.	11-0420-23	Low Pressure Control
	03-1638-04	Screw	10	18-1903-46	Potential Relay
	03-1417-15	Lockwasher	11.	12-2285-22	Transformer
3.	A32872-001	Run Cap Bracket	12	no number	Control Box Assy
	03-1652-02	Bolt	NOT ILLUSTRATED		
	03-0255-04	Wing Nut	13.	12-2337-02	3 Pin Plug Assy
4.	03-1638-03	Screw			(Safety Circuit to Circuit Board)
5.	18-1902-45	Run Capacitor	14.	12-2340-01	4 Pin Plug Assy
6.	12-2469-02	Single Phase Contactor			(Transformer to Circuit Board)
	12-0739-02	Three Phase Contactor	Separate From The Control Box		
			15.	12-2070-04	Fan Motor Relay
					(in a separate control box)



# FM2400R SERVICE PARTS

## Remote Condenser

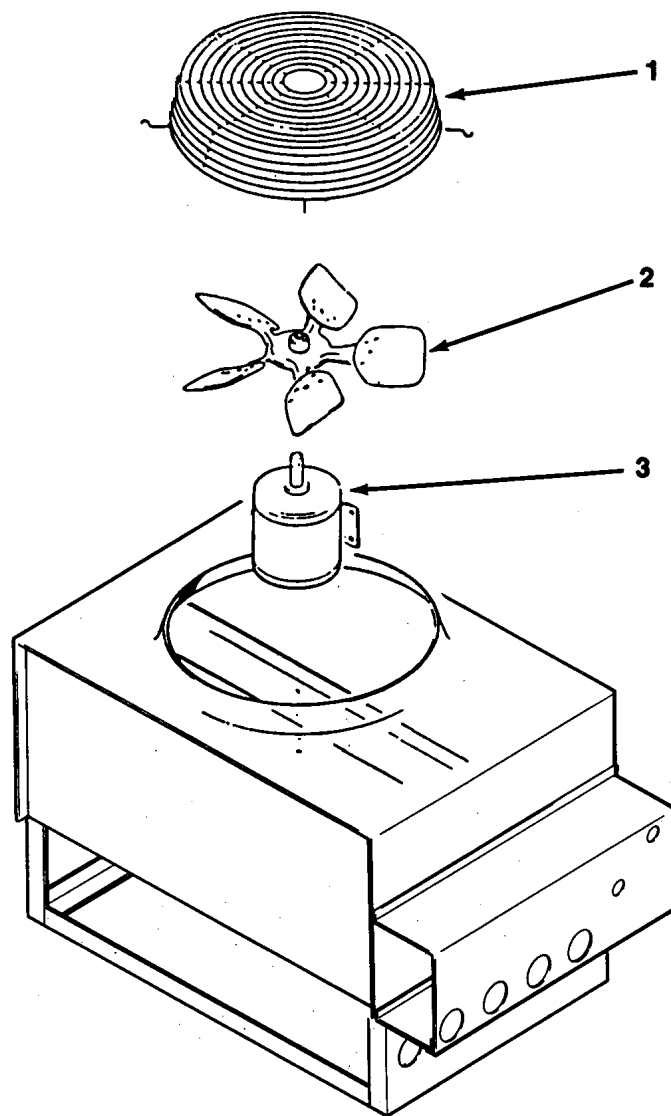

### RC1052-32A

ITEM NUMBER	PART NUMBER	DESCRIPTION
1.	02-2628-01	Fan Guard
2.	18-6304-01	Fan Blade
3.	18-5301-01	Fan Motor

# FM2400R SERVICE PARTS

Component Layout Diagram

208-230/60/1

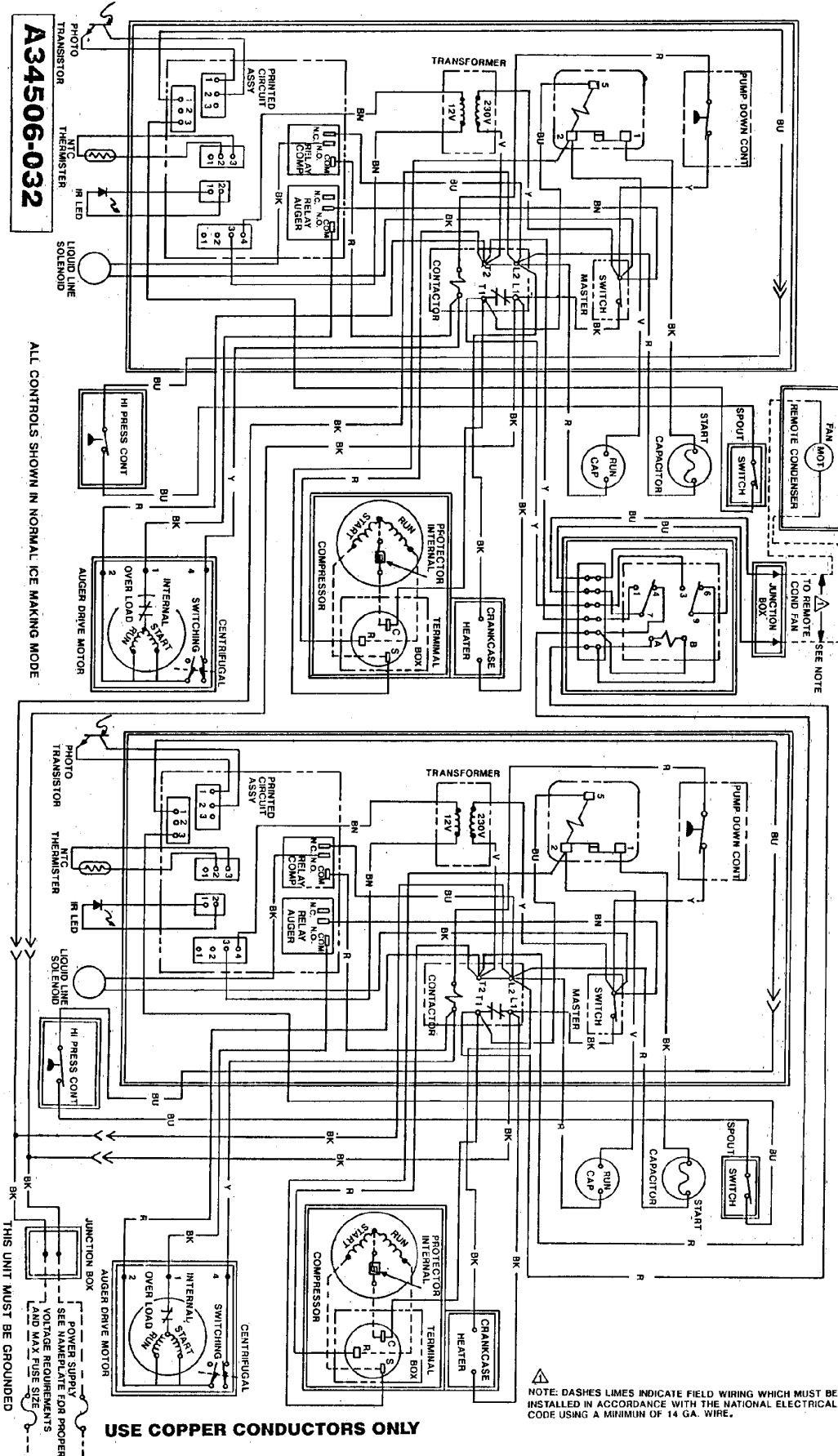

**A34506-032**

ALL CONTROLS SHOWN IN NORMAL ICE MAKING MODE

THIS UNIT MUST BE GROUNDING  
 POWER SUPPLY  
 SEE NAMEPLATE FOR PROPER  
 VOLTAGE REQUIREMENTS  
 AND MAX FUSE SIZE

**USE COPPER CONDUCTORS ONLY**

NOTE: DASHES LINES INDICATE FIELD WIRING WHICH MUST BE INSTALLED IN ACCORDANCE WITH THE NATIONAL ELECTRICAL CODE USING A MINIMUM OF 14 GA. WIRE.

# FM2400R SERVICE PARTS

Schematic Diagram

208-230/60/1

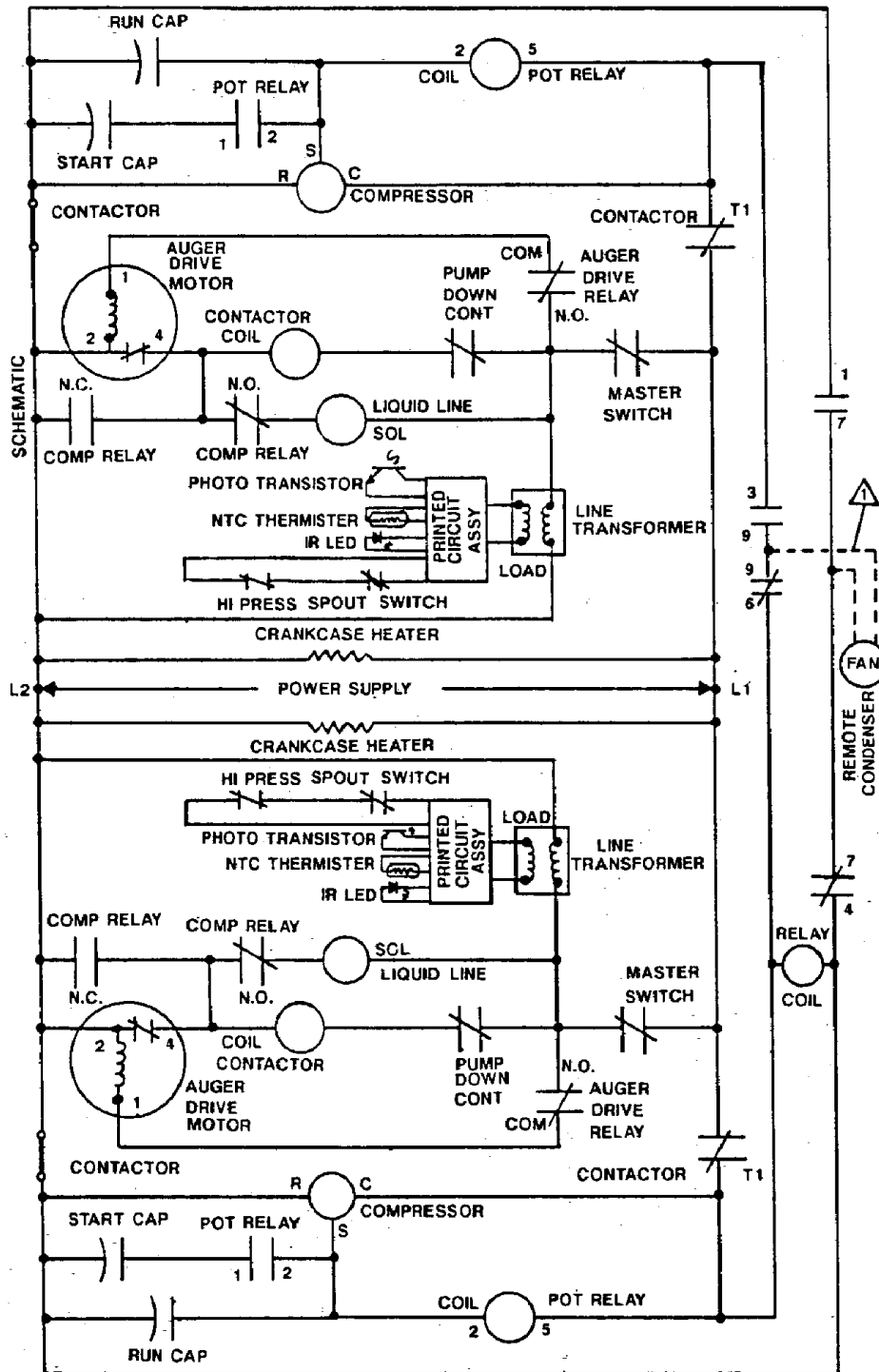

**USE COPPER CONDUCTORS ONLY THIS UNIT MUST BE GROUNDED**

All Controls Shown in Normal Ice Making Mode.

Note: Dashed lines indicate field wiring which must be installed in accordance with the National Electric Code Using a Minimum of 14 ga. awg. wire.

# FM2400R SERVICE PARTS

Component Layout Diagram

208-230/60/3

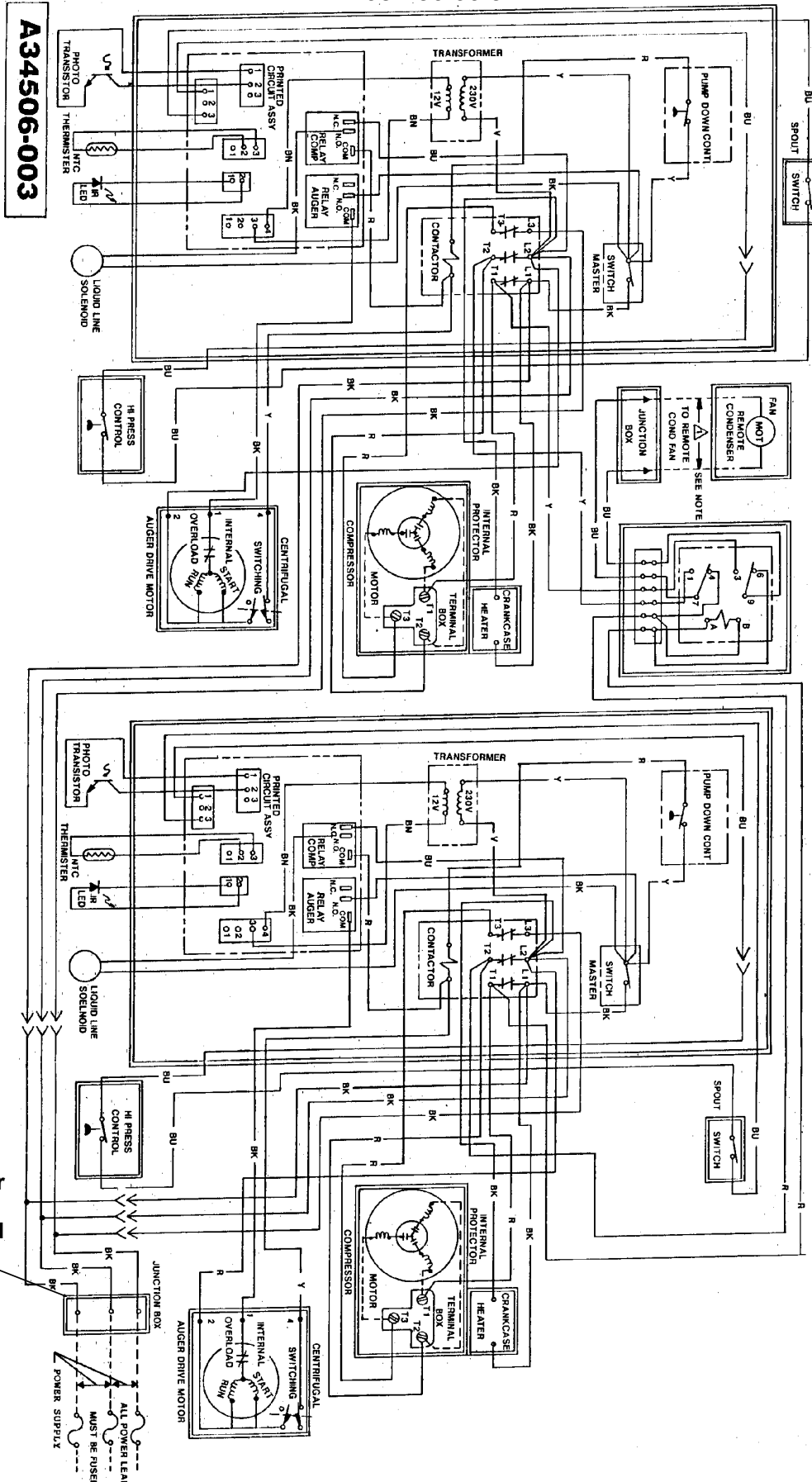

**Power Supply**  
 See Nameplate for  
 Proper Voltage  
 Requirements and  
 Max Fuse Size.  
 All Power Leads  
 Must Be Fused

# FM2400R SERVICE PARTS

Schematic Diagram

208-230/60/3

