

# FM2402RH SERVICE PARTS

This parts list contains the service parts and wiring diagrams for this model. Check the model number of the machine requiring the parts to be sure that this is the correct parts list.

## TABLE OF CONTENTS

Cabinet Assembly .....	Page 2
Water System .....	Page 3
Refrigeration System .....	Page 4
Evaporator .....	Page 5
Gearmotor .....	Page 6
Control Box .....	Page 7
Wiring Diagrams .....	Page 8

# FM2402RH SERVICE PARTS

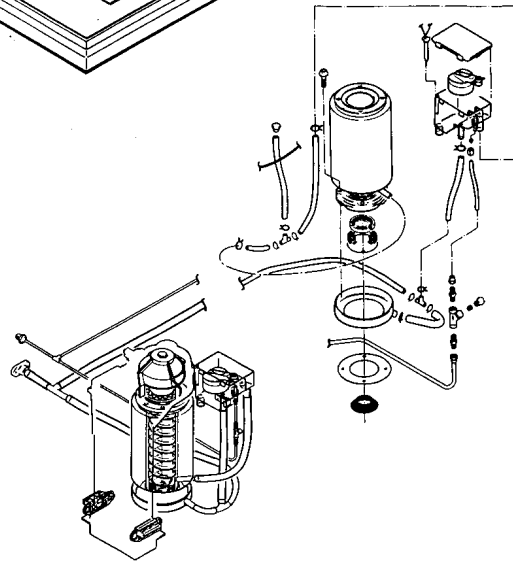
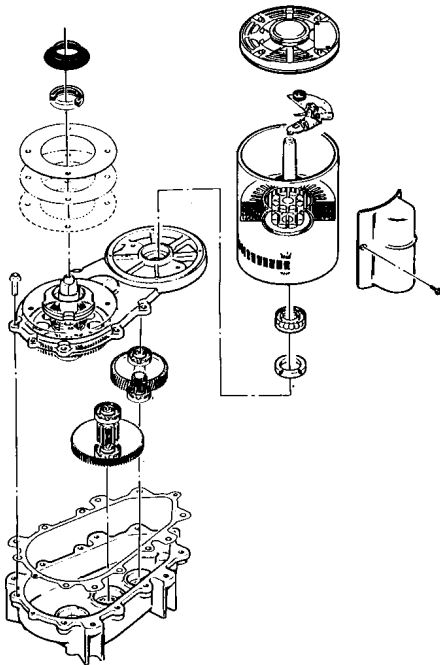
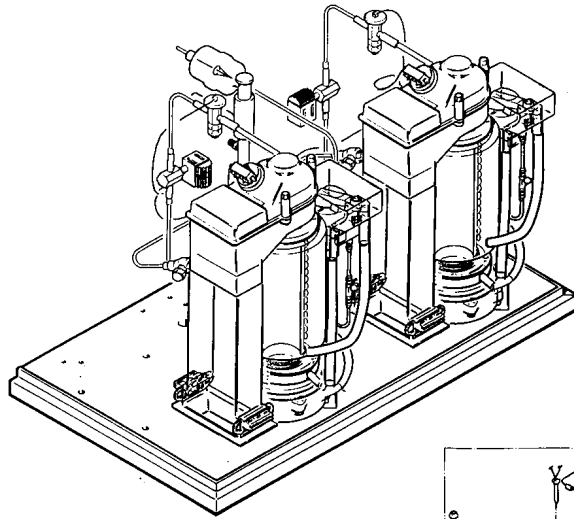
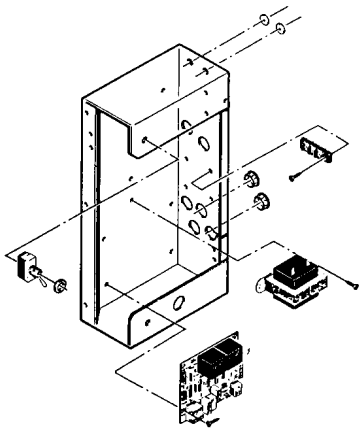
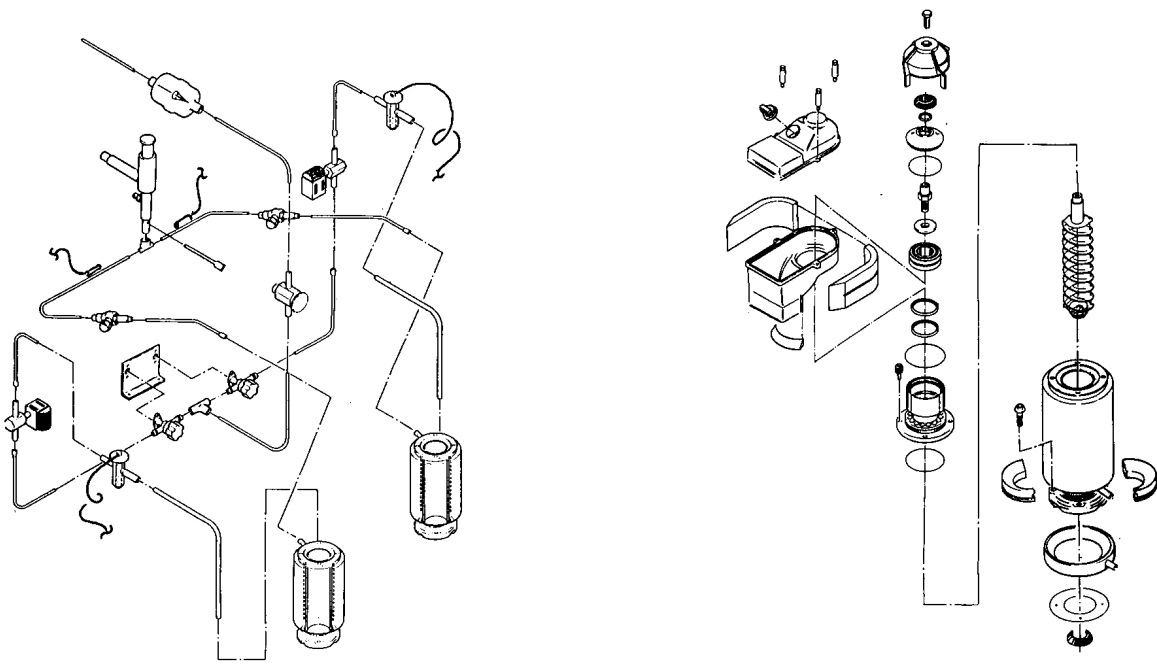

# FM2402RH SERVICE PARTS

## Cabinet

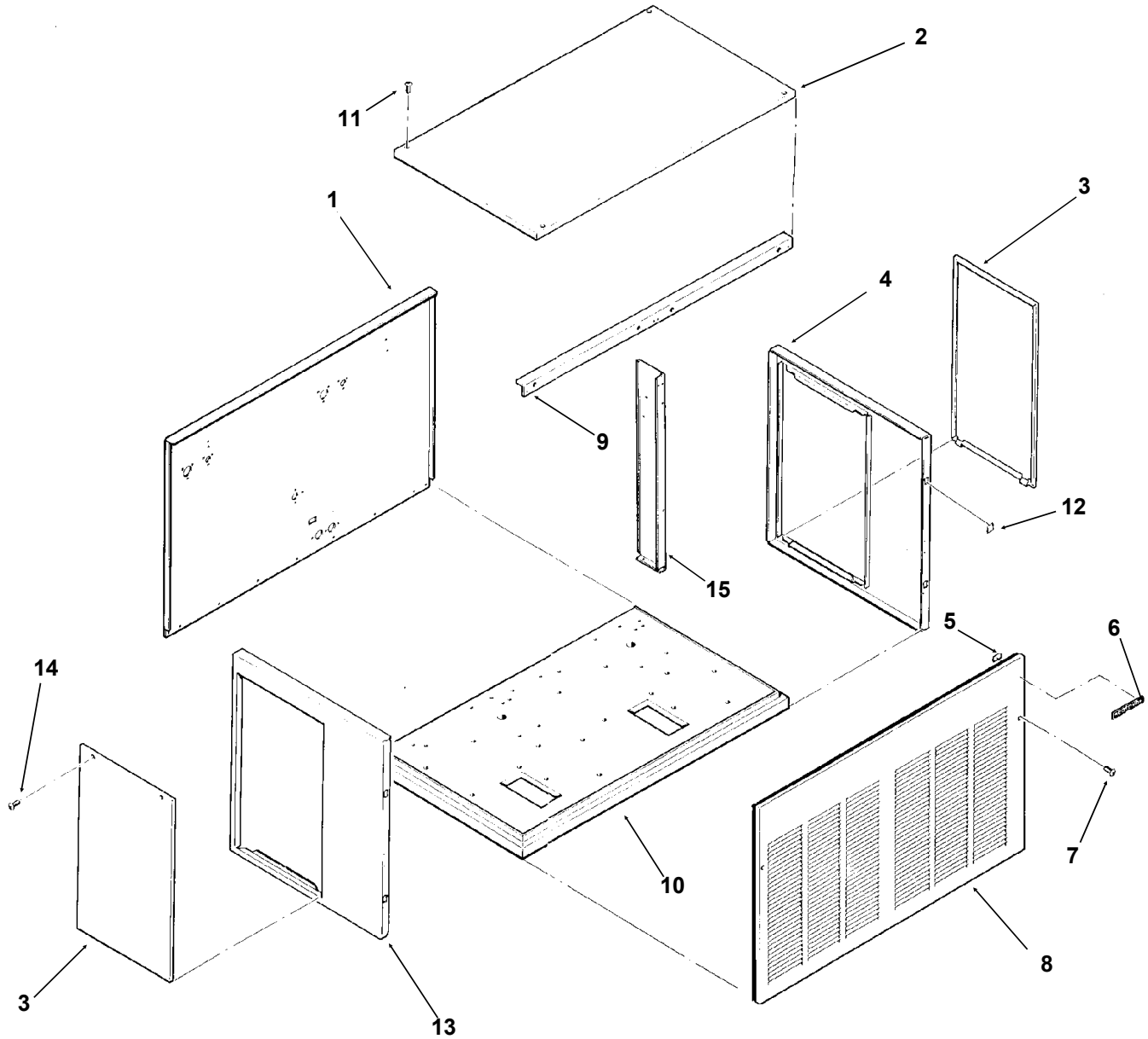

ITEM NUMBER	PART NUMBER	DESCRIPTION	ITEM NUMBER	PART NUMBER	DESCRIPTION
1	A34283-001	Back Panel, Painted	9	A34287-001	Support
2	A32461-001	Top Panel, Painted	10	A34282-001	Base
	A32461-002	Top Panel, S.S.	11	03-1531-01	Screw
3	A34038-001	Service Panel, Painted	12	02-0836-00	Catch
	A34038-002	Service Panel, S.S.	13	A32435-001	Left Side Panel, Painted
4	A33292-001	Right Side Panel, Painted		A32435-002	Left Side Panel, S.S.
	A33292-002	Right Side Panel, S.S.	14	03-1404-12	Screw
5	03-0271-00	Speed Clip	15.	A34286-001	Center Support
6	15-0711-01	Emblem			
7	03-1419-08	Screw			
8	A34294-001	Front Panel, Painted			
	A34294-002	Front Panel, S.S.			

# FM2402RH SERVICE PARTS

## Water System

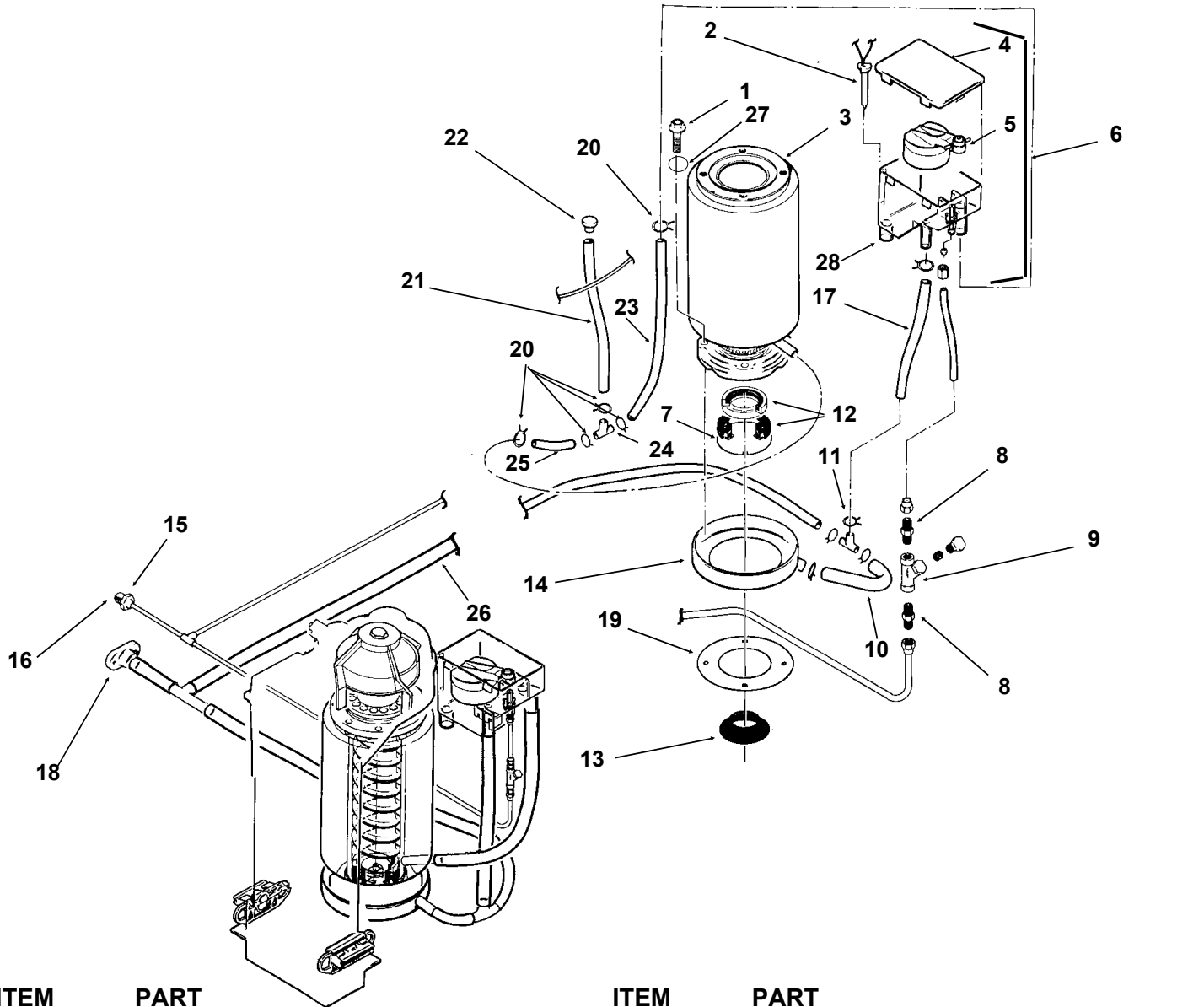

ITEM NUMBER	PART NUMBER	DESCRIPTION	ITEM NUMBER	PART NUMBER	DESCRIPTION
1	03-1420-03	Cap Screw	15	A27318-001	Water Inlet Fitting
2	A33101-022	Water Level Sensor	16	03-1394-01	Pal Nut
3	A32890-020	Evaporator	17	13-0079-03	Res. Overflow, 8" req.
4	02-2936-01	Res. Cover	18	A32282-004	Drain Casting
5	A32907-001	Float Assembly with pin, housing seal, rubber seal, insert & float	19	13-0704-00	Gasket
	02-3190-01	Valve seat	20	02-2814-08	Clamps
6	A32929-020	Reservoir Assembly	21	13-0674-06	Evap. Drain, 14" req.
7	A32777-021	Retaining Ring for Seal	22	A33205-001	Plug
8	16-0791-01	Half Union	23	13-0674-06	Evap. Inlet Tube, 5" req.
9	16-0162-00	Strainer	24	16-0670-01	Tee
10	13-0079-03	Tube, 6.5" req.	25	A33203-001	Tube, Preformed
11	16-0670-02	Tee	26	13-0079-03	Drain Tube, 24" req.
12	02-0929-22	Water Seal	27	03-1417-13	Lockwasher
13	13-0868-01	Water Shed	28	13-0230-00	Rubber cap
14	A32050-001	Drip Pan		02-2814-01	Clamp

# FM2402RH SERVICE PARTS

## Refrigeration System

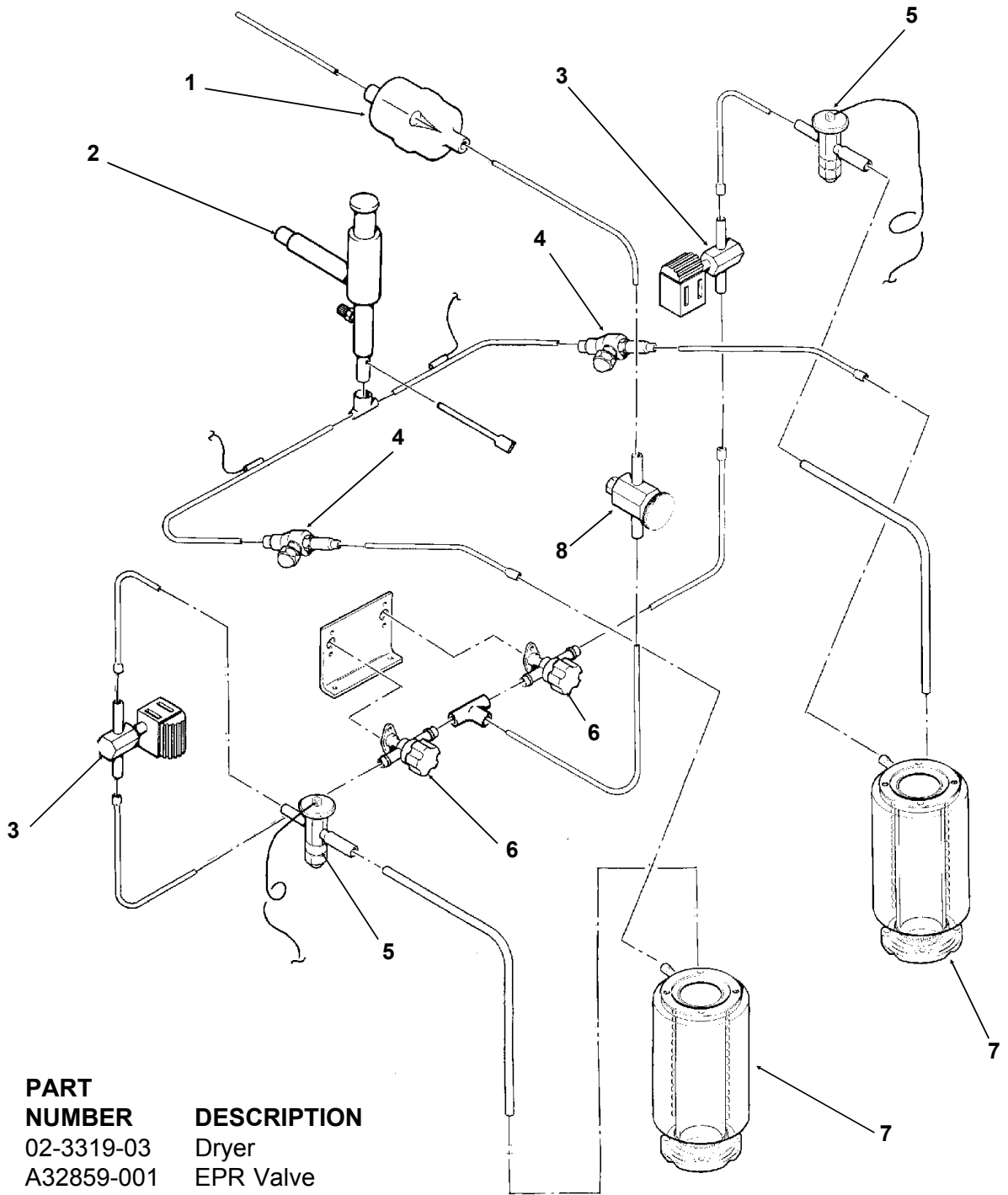

ITEM NUMBER	PART NUMBER	DESCRIPTION
1	02-3319-03	Dryer
2	A32859-001	EPR Valve
3	12-2257-01	Solenoid Valve
4	A32855-001	Ball Valve
5	16-0825-01	Thermostatic Expansion Valve
6	A32858-001	Shut Off Valve
7	A32890-020	Evaporator
8	16-0672-02	Sight Glass

# FM2402RH SERVICE PARTS

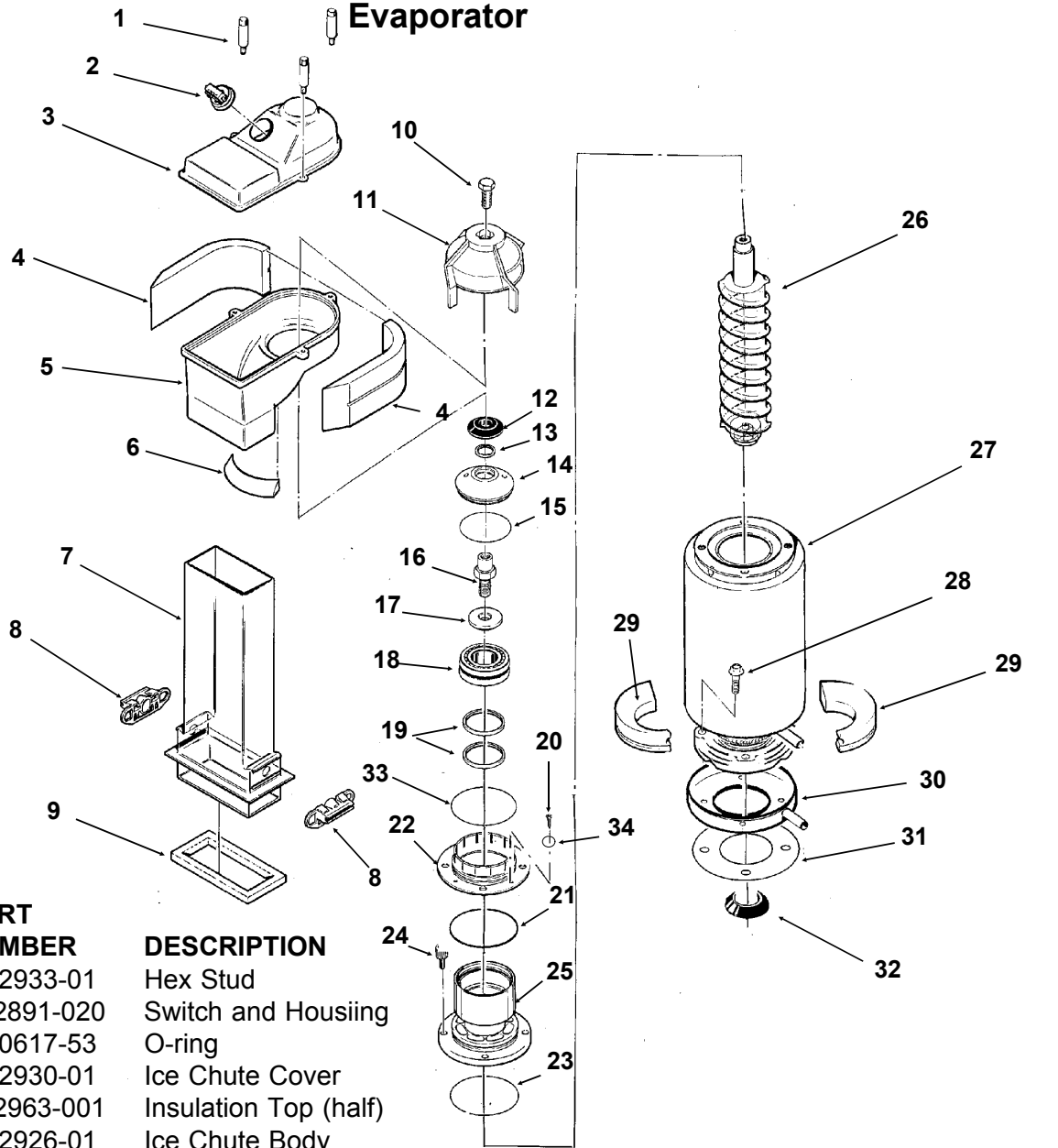

ITEM NUMBER	PART NUMBER	DESCRIPTION
1.	02-2933-01	Hex Stud
2.	A32891-020	Switch and Housing
	13-0617-53	O-ring
3.	02-2930-01	Ice Chute Cover
4.	A32963-001	Insulation Top (half)
5.	02-2926-01	Ice Chute Body
6.	A33102-001	Insulation Collar Inside
	A35419-020	Strap Kit
7.	02-2929-01	Ice Chute Lower
8.	A37708-021	Bin Controls Assy. (set of 2)
9.	A32930-001	Chute Gasket
10.	03-1405-52	Hex Cap Screw
11.	02-3001-01	Ice Sweep
12.	13-0871-01	Water Shed
13.	02-2978-01	Lip Seal
14.	02-3128-01	Breaker Cover
15.	13-0617-54	O-Ring
16.	08-0660-01	Auger stud & washer part of item 16
17.		
18.	A34559-020	Bearing
19.	02-2977-01	Lip Seal
20.	03-1405-27	Screw
21.	13-0617-52	O-Ring
22.	02-2916-01	Slotted Collar
23.	13-0617-45	O-Ring
24.	03-1544-08	Soc. Head Screw
25.	A34505-020	Breaker (Divider) (includes 18 & 19)
26.	A38071-022	Auger
27.	A32890-020	Evaporator
28.	03-1420-03	Cap Screw
29.	A32962-001	Insulation Bot. (half)
30.	A32050-001	Drip Pan
31.	13-0704-00	Drip Pan Gasket
32.	13-0868-01	Water Shed
33.	13-0617-49	O-Ring
34.	03-1408-36	Washer

# FM2402RH SERVICE PARTS

## Gearmotor

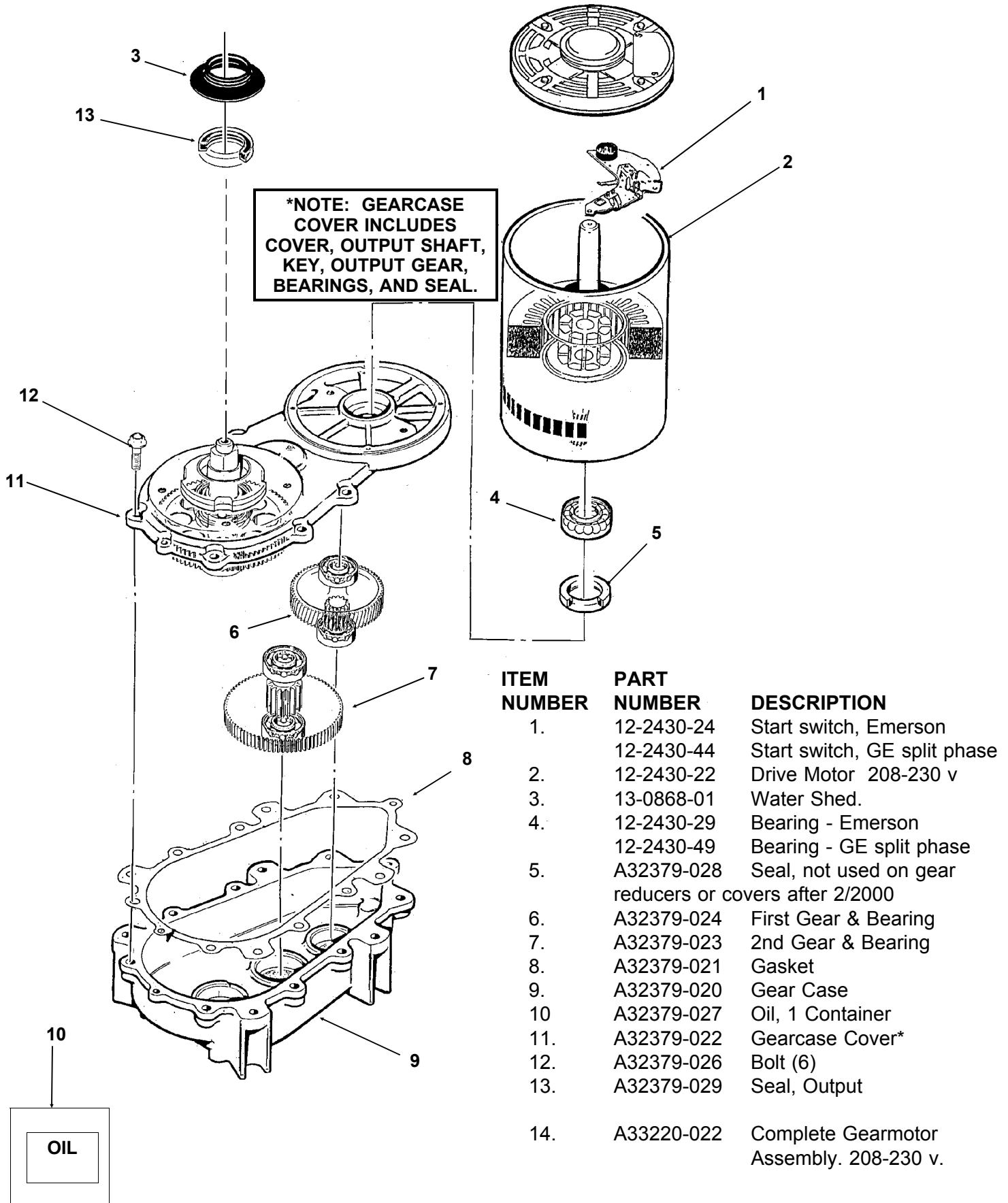

# FM2402RH SERVICE PARTS

## Control Box

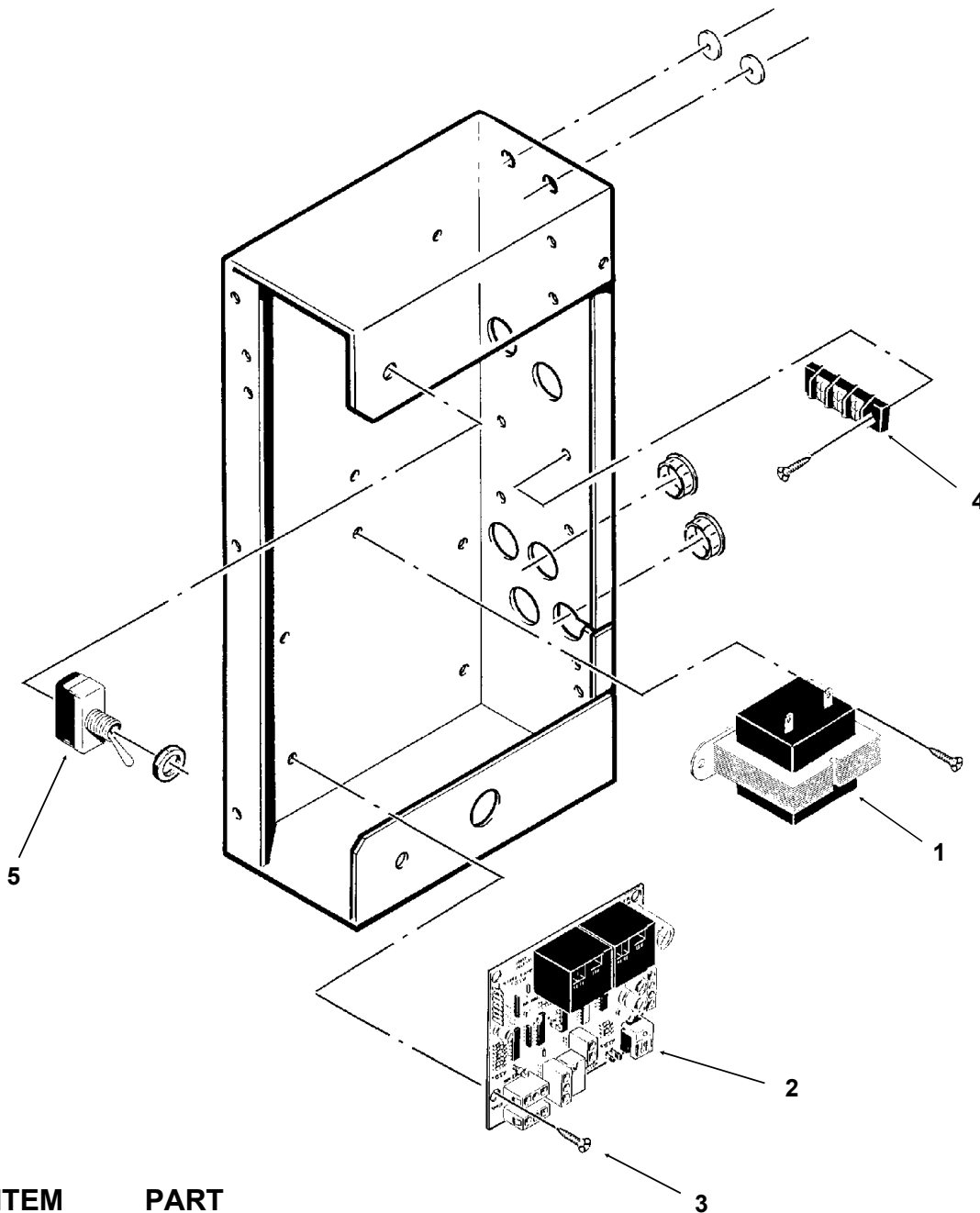

ITEM NUMBER	PART NUMBER	DESCRIPTION
1	12-2285-22	Transformer
2	A37750-021	Circuit Board
3	12-2350-01	Stand off
4	12-0813-04	Terminal Strip
5	12-0426-01	Master Switch

Not Illustrated:

6	12-2337-03	Wire Harness to spout switch
7	12-2340-01	Wire harness to transformer
8	A34055-001	Control Box Cover



# FM2402RH SERVICE PARTS

## Wiring Diagram

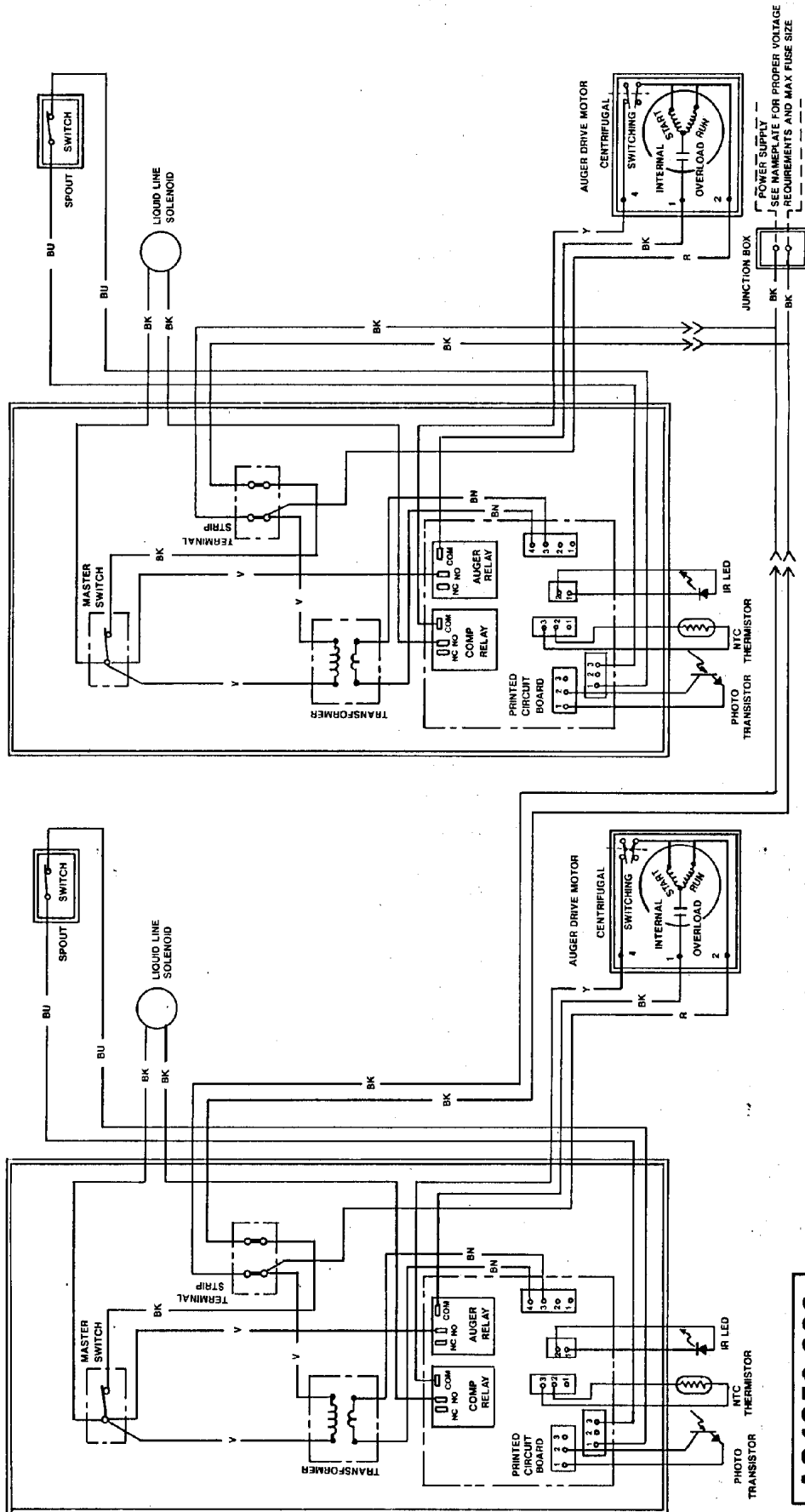

**A34350-032**

# FM2402RH SERVICE PARTS

## Schematic Diagram

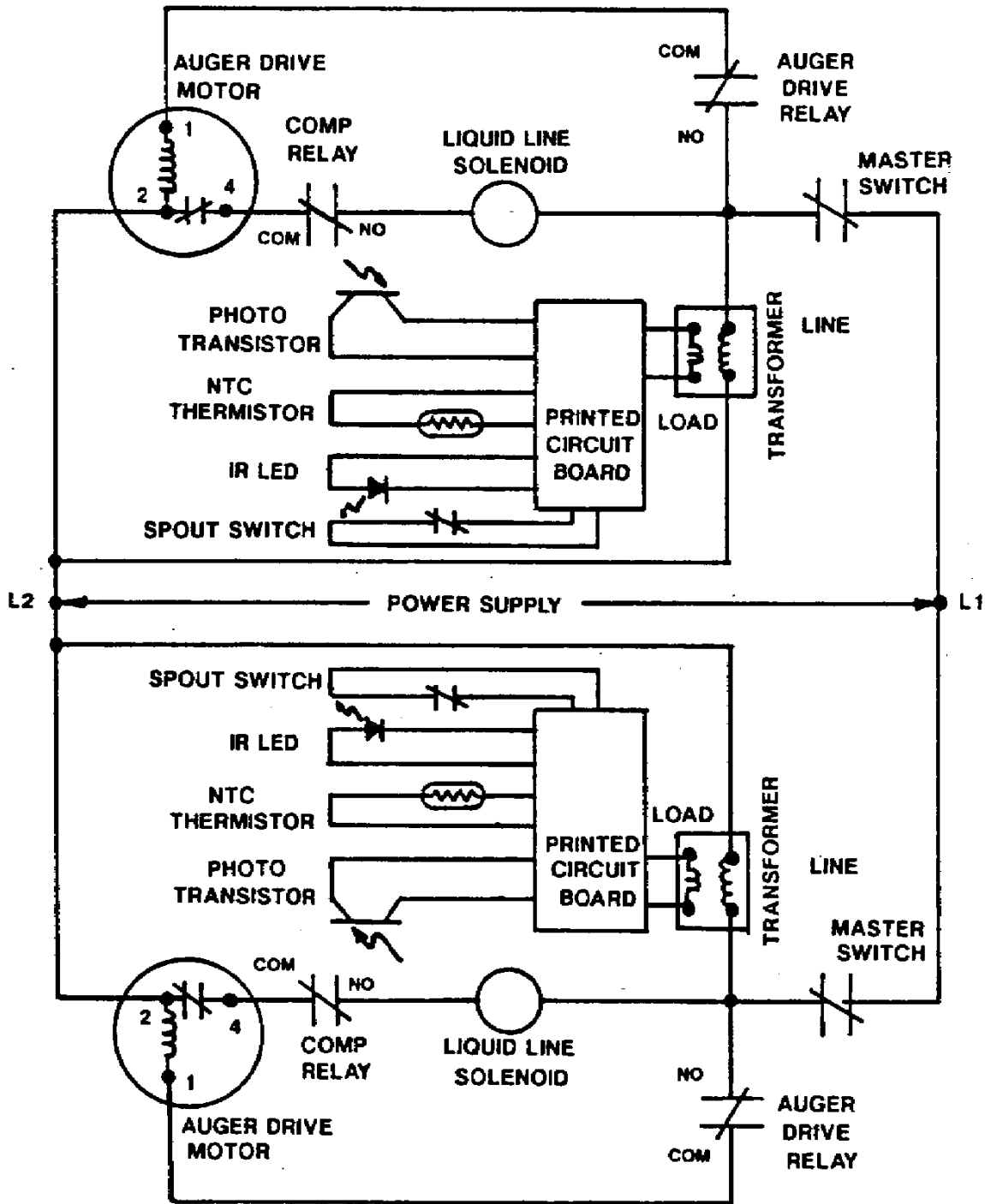

### USE COPPER CONDUCTORS ONLY

NOTE: DASHED LINES INDICATE FIELD WIRING WHICH MUST BE INSTALLED  
IN ACCORDANCE WITH THE NATIONAL ELECTRICAL CODE USING A  
MINIMUM OF 14 GA. AWG WIRE

ALL CONTROLS SHOWN IN NORMAL ICE MAKING MODE

THIS UNIT MUST BE GROUNDED