

INTRODUCTION

To the owner or user: This manual is intended to provide you, and the maintenance or service technician, with the information needed to install, start up, clean, maintain, and service this ice system.

This is a modular type ice system that fits a variety of Scotsman ice storage bins.

Its features include: front service for the freezer, gear motor, control box, water reservoir, and bin control; an electronic circuit for monitoring ice and water level; a thermostatic expansion valve; and R-404A as the refrigerant.

Table of Contents

- FOR THE INSTALLER Page 2
- SAMPLE BIN AND MACHINE COMBINATIONS Page 3
- FOR THE INSTALLER Page 4
- FOR THE INSTALLER: Location Page 5
- FOR THE PLUMBER Page 6
- FOR THE ELECTRICIAN Page 7
- FOR THE INSTALLER Page 8
- START UP Page 9
- COMPONENT DESCRIPTION Page 10
- COMPONENT DESCRIPTION Page 11
- CONTROL BOX: Components Page 12
- ELECTRICAL SEQUENCE: Page 13
- OPERATION: Water Page 14
- OPERATION: Performance Page 15
- SANITIZING AND CLEANING Page 16
- SENSOR MAINTENANCE Page 17
- BEARING MAINTENANCE Page 18
- MAINTENANCE: Air Cooled Page 19
- AUGER MAINTENANCE Page 20
- SERVICE DIAGNOSIS Page 21
- SERVICE DIAGNOSIS Page 22
- CONTROL SYSTEM DIAGNOSTICS Page 23
- REMOVAL AND REPLACEMENT: Water Reservoir & Bin Controls Page 24
- REMOVAL AND REPLACEMENT: Bearing And Breaker Page 25
- REMOVAL AND REPLACEMENT: Auger Page 26
- REMOVAL AND REPLACEMENT: Water Seal Page 27
- REMOVAL AND REPLACEMENT: Evaporator Page 28
- REMOVAL AND REPLACEMENT: Gearmotor Page 29
- REMOVAL AND REPLACEMENT: Fan Blade and Motor Page 30
- REFRIGERATION SYSTEM SERVICE Page 31
- What to Do Before Calling for Service Page 32

This manual was printed on recycled paper. Keep it for future reference.

Note the warning symbol where it appears. It marks a possible hazard.



NME954 & FME1204 FOR THE INSTALLER

BACK VIEW: AIR COOLED

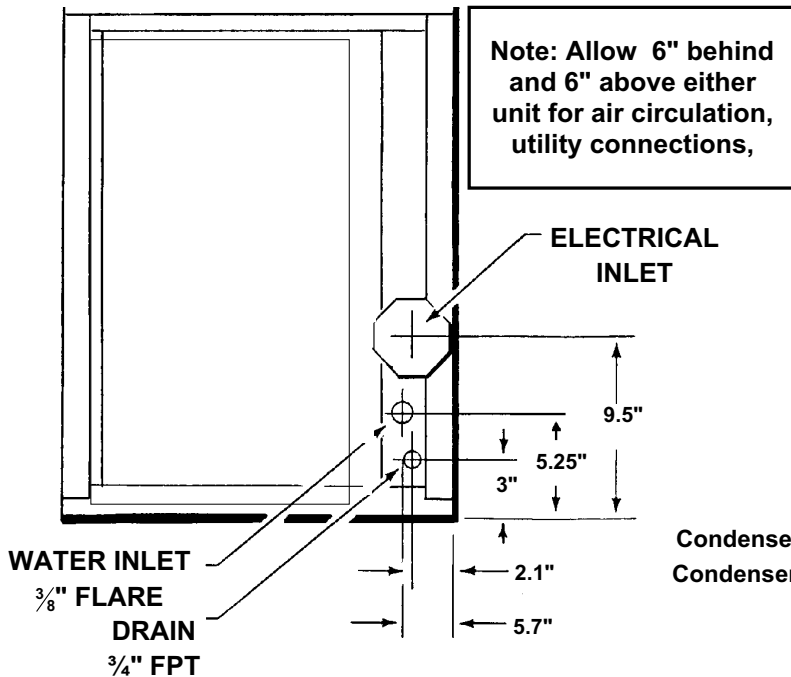

BACK VIEW: WATER COOLED

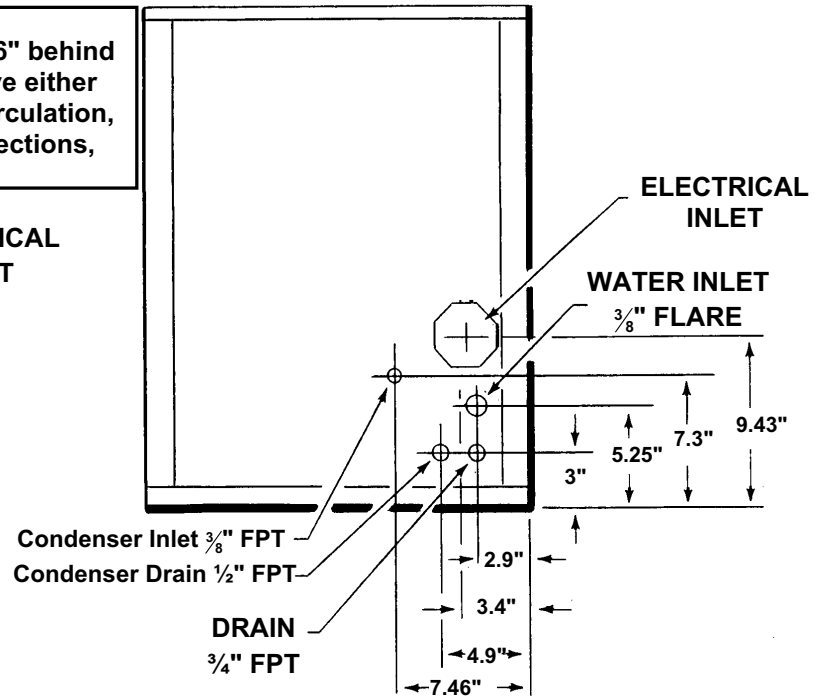

These models are designed to fit the following Scotsman storage bins:

- SB480 and extensions (with bin top KBT18)
- BH800 using bin top KBT15 (one unit) or KBT25 (two units).
- BH801 using bin top KBT28
- BH900 with KBT24 (one unit)
- BH900 with KBT25 (two units side by side)

NME954 Dispenser Applications

The NME954 can be placed on and used with certain ice and ice-beverage dispensers. Kits are required for proper operation:

- ID150 use adapter KBT42 and KNUGDIV
- ID200 or ID250, use adapter KBT46 and KDIL-N-ID2
- Cornelius ED/DF200 beverage dispensers, use KBT46 and KDIL-N-200
- Cornelius ED/DF250 beverage dispensers, use KBT46 and KDIL-N-250
- Lancer nugget IBD, use KDIL-N-L & Lancer kit.

SPECIFICATIONS: Ice Machine

Model Number	Dimensions (w/o bin)	Basic Electrical	Ice Type	Condenser Type	Minimum Circuit Ampacity	Maximum Fuse Size	Refrigerant Charge R-404A*
	W x D x H						
FME1204AS-3B	21" x 24" x 27"	208-230/60/3	FLAKE	Air	8.4	15	30 oz
FME1204WS-3A	same	same	FLAKE	Water	7.9	15	24 oz
FME1204WS-3B	same	same	FLAKE	Water	7.9	15	22 oz
FME1204AS-32B	same	208-230/60/1	FLAKE	Air	11.3	15	30 oz
FME1204WS-32A	same	same	FLAKE	Water	10.8	15	24 oz
FME1204WS-32A	same	same	FLAKE	Water	10.8	15	22 oz
NME954AS-3B	same	208-230/60/3	NUGGET	Air	8.4	15	30 oz
NME954WS-3A	same	same	NUGGET	Water	7.9	15	24 oz
NME954WS-3B	same	same	NUGGET	Water	7.9	15	22 oz
NME954AS-32B	same	208-230/60/1	NUGGET	Air	11.3	15	30 oz
NME954WS-32A	same	same	NUGGET	Water	10.8	15	24 oz
NME954WS-32B	same	same	NUGGET	Water	10.8	15	22 oz

* Refrigerant charge change on water cooled. Always check the nameplate for charge data.

NME954 & FME1204

SAMPLE BIN AND MACHINE COMBINATIONS

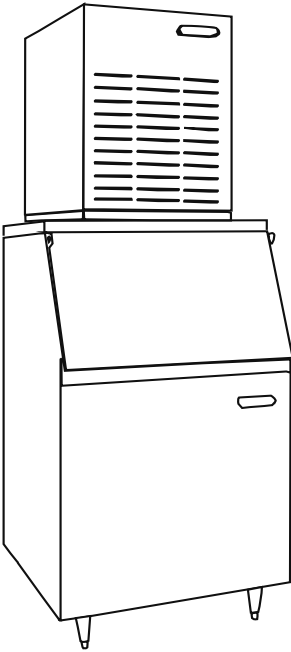

FME1204 ON BH550*

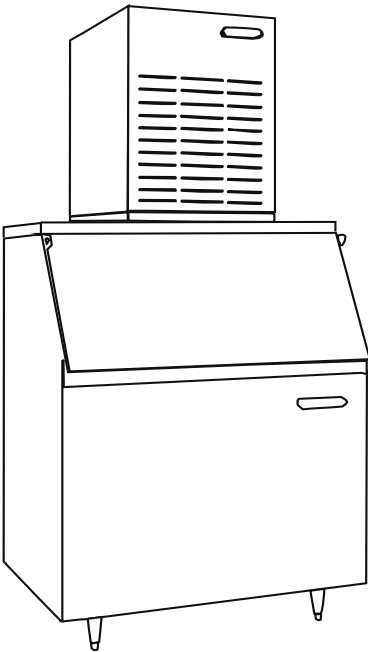

NME954 ON BH800*

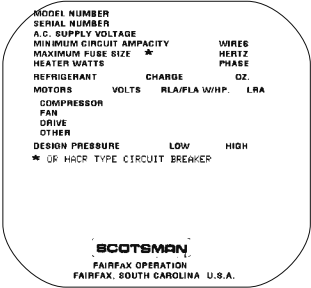

The Nameplate is located on the back of the machine.

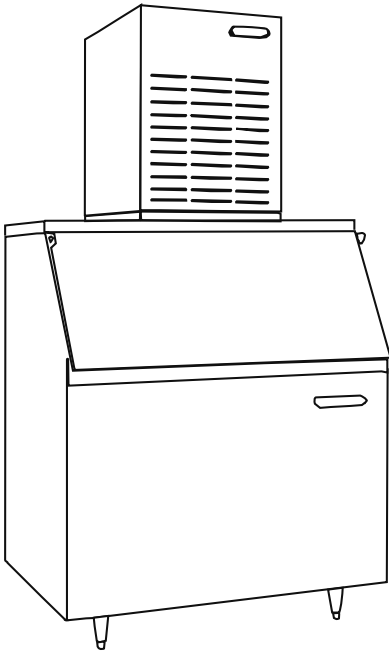

FME1204 ON BH900*

* Bin Top Kit Required

NME954 & FME1204

FOR THE INSTALLER

Notice:

Scotsman Ice Systems are designed and manufactured with the highest regard for safety and performance. They meet or exceed the standards of UL, NSF and CUL.

Scotsman assumes no liability or responsibility of any kind for products manufactured by Scotsman that have been altered in any way, including the use of any part and/or other components not specifically approved by Scotsman.

Scotsman reserves the right to make design changes and/or improvements at any time. Specifications and design are subject to change without notice.

Location:

Installation Limitations:

This ice system is designed to be installed indoors, in a controlled environment:

	Min	Max
Air Temperature	50 ⁰ F	100 ⁰ F
Water Temperature	40 ⁰ F	100 ⁰ F
Water Pressure	20 PSI	80 PSI
Voltage	198	253

(Compared to the nameplate)

Operating the machine outside of the limitations is misuse and can void the warranty.

RO Water Limitation: Water conductivity must be no less than 35 microSiemens/cm.

Only install the machine in a location where there is enough space around it so that it is accessible for service.

Keep the back of air cooled machines a minimum distance of 6" from a wall for air circulation. Try to avoid hot, dirty and crowded locations. Be sure that the location for the machine is within the environmental limitations.

Storage Bin:

Tip the storage bin on its back, using parts of the carton to protect the exterior finish. Remove the skid and install the legs into the threaded holes in the bottom of the bin. Turn the leg levelers all the way in preparation for leveling later. Return the bin to the upright position, remove paper covering the bin gasket.

Note: Do not push bin into position, instead lift it there. Pushing a bin, especially one with ice in it, can cause damage to the legs and the leg mounts.

Install the appropriate bin top on the bin, according to the instructions for the bin top.

Ice Machine:

The machine is heavy, so the use of a mechanical lift is recommended for lifting the machine high enough to install on top of the bin. After the unit is placed on the bin, line it up so it is even with the back side. Secure the machine to the bin with the hardware provided with the machine.

Remove the front panel and remove any shipping blocks.

FOR THE INSTALLER: Location

A proper installation locates the machine indoors, but in a place where the heat and noise it produces are not objectionable.

Air cooled machines discharge hot air out the back. 6" of space behind the machine is the minimum required for adequate operation of an air cooled unit.

Space for maintenance access is also important. If two units are placed side by side on a bin, side access becomes even more important.

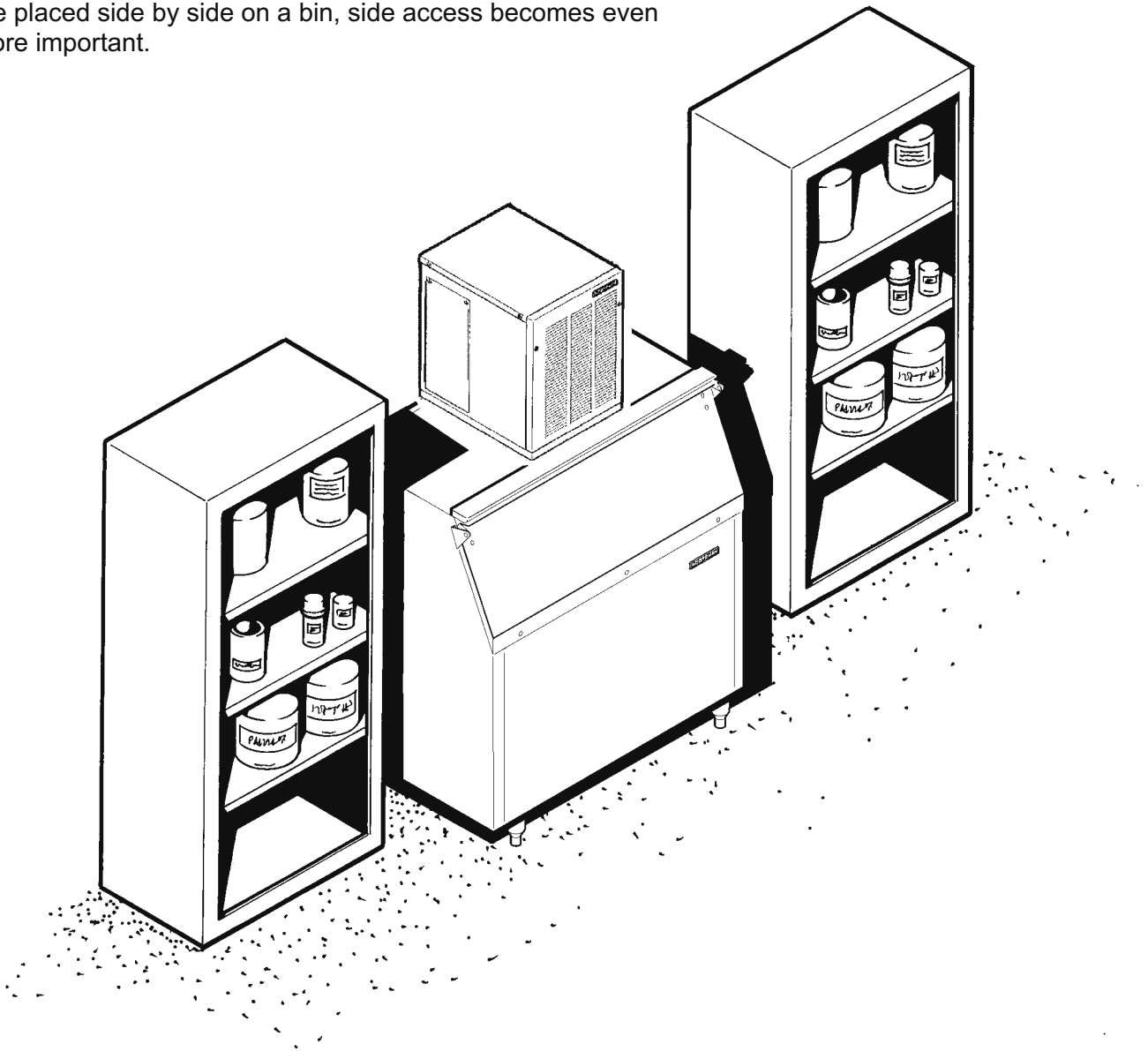

NME954 & FME1204 FOR THE PLUMBER

CONFORM TO ALL APPLICABLE CODES

Water Inlet

Air Cooled Models: The recommended water supply is clean, cold water. Use $\frac{3}{8}$ " O.D. copper tubing, connect to the $\frac{3}{8}$ " male flare at the back of the cabinet. Install a hand valve near the machine to control the water supply.

Water Treatment: In most areas, a water filter of some type will be useful. In areas where the water is highly concentrated with minerals the water should be tested by a water treatment specialist, and the recommendations of the specialist regarding filtration and/or treatment should be followed.

Water Cooled Models: A separate $\frac{3}{8}$ " O.D. copper line is recommended, with a separate hand valve to control it. Connect it to the $\frac{3}{8}$ " FPT condenser inlet at the back of the cabinet. The water pressure to all lines must always be above 20 psig, and below 80 psig.

Drains

Air Cooled Models: Connect a **rigid** drain tube to the $\frac{3}{4}$ " FPT drain fitting at the back of the cabinet. The drain is a gravity type, and $\frac{1}{4}$ inch per foot fall is the minimum acceptable pitch for the drain tubing. There should be a vent at the highest point of the drain line, and the ideal drain receptacle would be a trapped and vented floor drain. Use only $\frac{3}{4}$ " rigid tubing.

Water Cooled Models: Connect a separate drain line to the $\frac{1}{2}$ " condenser drain connection at the back of the cabinet. Do not vent this drain.

Storage Bin: Connect a **separate** gravity type drain to the ice storage bin drain. Vent this drain if there is a long horizontal run from the bin to the floor drain. Insulation of this drain line is recommended.

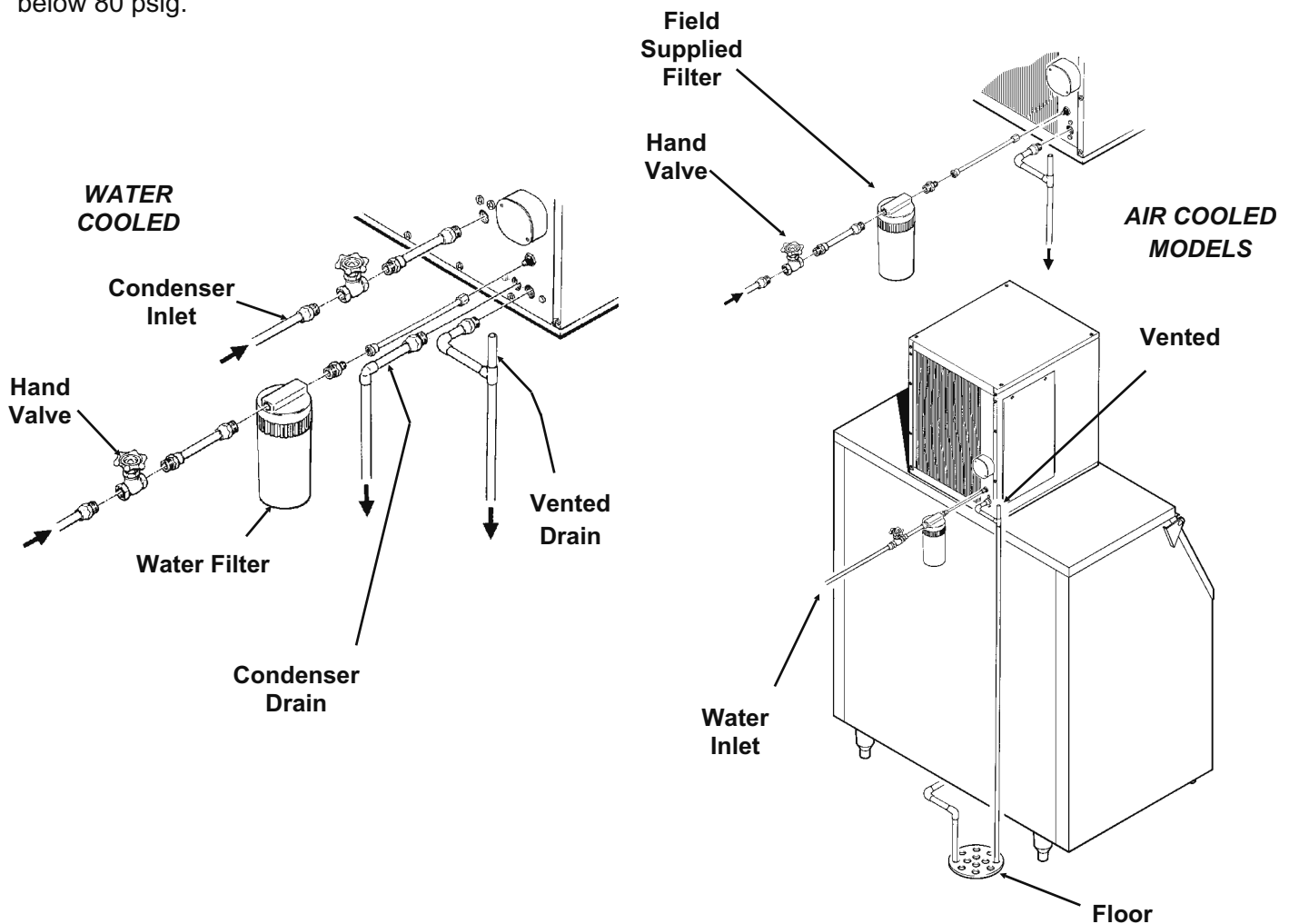

FOR THE ELECTRICIAN

CONFORM TO ALL APPLICABLE CODES

Check the nameplate (located on the back panel) for the voltage requirements, and for the minimum circuit ampacity. The machine requires a solid chassis to earth ground wire.

Connect the power supply to the wires leads in the junction box on the back of the machine.

remain within the limitations, even under starting conditions.

All external wiring must conform to national, state, and local electrical codes. The use of a licensed electrician is required to perform the electrical installation.

Connect the ice machine to its own electrical circuit so it is individually fused. Voltage variation must

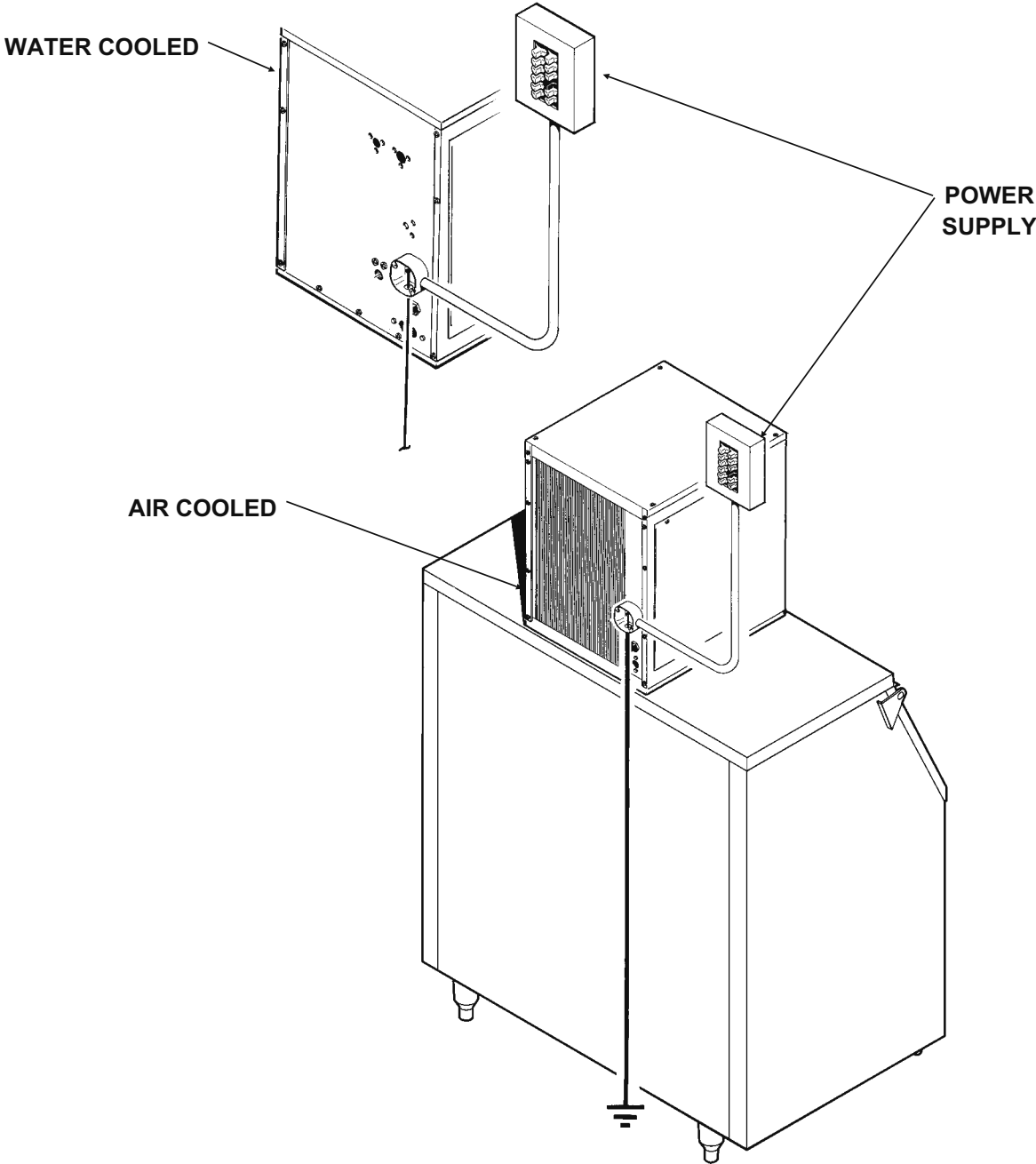

NME954 & FME1204

FOR THE INSTALLER

Final Check List

- ___ 1. Is the ice system installed indoors in a location where the air and water temperatures are controlled, and where they do not exceed the design limitations?

- ___ 2. Is there an electrical service disconnect within sight of the installed machine? Has the voltage been checked, and compared to nameplate requirements?

- ___ 3. Have all the plumbing connections been made and checked for leaks?

- ___ 4. Has the machine and bin been leveled?

- ___ 5. Is there a minimum of 6" clearance at the back of the machine for proper service access and air circulation?

- ___ 6. Is the water pressure a minimum of 20 psig?

- ___ 7. Has the machine been secured to the bin?

- ___ 8. Is there clearance over the top of the machine for service access?

- ___ 9. Is there a water shut off valve installed near the machine?

- ___ 10. Have all of the shipping blocks been removed?

START UP

Pre-Start Inspection

1. Remove the front and side service panels.
2. Check that any shipping blocks have been removed.
3. Inspect the interior of the machine for loose screws or wires. Check that no refrigerant lines are rubbing each other. Check that the fan blades turn freely (air cooled).
4. Check that the unit is installed correctly according to the final check list (page 8).

Start Up

1. Go through the prestart inspection.
2. Open the hand valve, observe that water enters the water reservoir, fills the tube from the reservoir to the evaporator, and then shuts off. Check for leaks.
3. Switch the master (mode) switch on.
The electrical start up sequence is automatic.
A. There should be a short (15 second) delay before the gear motor starts.
B. After the gear motor starts, the compressor will start.
4. On air cooled models, the condenser will begin to discharge warm air, on water cooled models, the water regulating valve will open, and warm water will be discharged into the drain.
5. The unit should soon be making ice, if desired, the low side pressure may be checked: it should be 32 psig + or - 2 psig.
The suction line temperature at the compressor is normally very cold, nearly to the point of frost up to the compressor body, but not on it.
The air cooled discharge pressure will depend upon air and water temperatures, but should be between 200 psig and 280 psig.
The water cooled discharge pressure should be constant at about 245 psig.

The above numbers are for new, clean machines, you can expect to see some values higher, and some lower between different units.

6. THERE ARE NO ADJUSTMENTS TO MAKE, so replace the panels.

7. Clean and/or sanitize the storage bin interior, wipe off the exterior with a clean, damp cloth.

8. Give the owner/user the service manual, instruct him/her in the operation of the unit, and make sure they know who to call for service.

9. Fill out the manufacturer's registration and mail it to Scotsman.

NME954 & FME1204

COMPONENT DESCRIPTION

Control Box: Contains the electrical controls that operate the machine.

High Pressure Cut Out Switch: An auto-reset switch sensing the high side refrigeration pressure. It will shut the machine off if the discharge pressure should ever exceed 450 psig.

Low Pressure Cut Out Switch: An auto-reset switch sensing the low side of the refrigeration system. It will disconnect power to the circuit board and shut down the machine if the low side pressure falls too low.

Evaporator: A vertical stainless steel tube, refrigerated and water filled. In it there is a stainless steel auger.

Compressor: The refrigerant vapor pump.

Reservoir: Float operated, it maintains the water level in the evaporator at a constant level, it also contains the water level sensor.

Water Level Sensor: Senses if there is water in the reservoir to make ice out of. Will shut the machine off if there is none.

Ice Discharge Chute: Directs the ice produced by the evaporator into the storage bin.

Ice Level Sensor: An electronic "eye", it senses the presence of ice in the bottom of the ice discharge chute. Operates to turn the ice machine on and off automatically as the level of ice in the bin changes.

Gear Motor: An oil filled, speed reduction gearbox, driving the auger.

Drain Tube: When uncapped and lowered, drains the evaporator.

Condenser: Air or water cooled, where the heat removed in ice making is discharged.

Expansion valve: The refrigerant metering device.

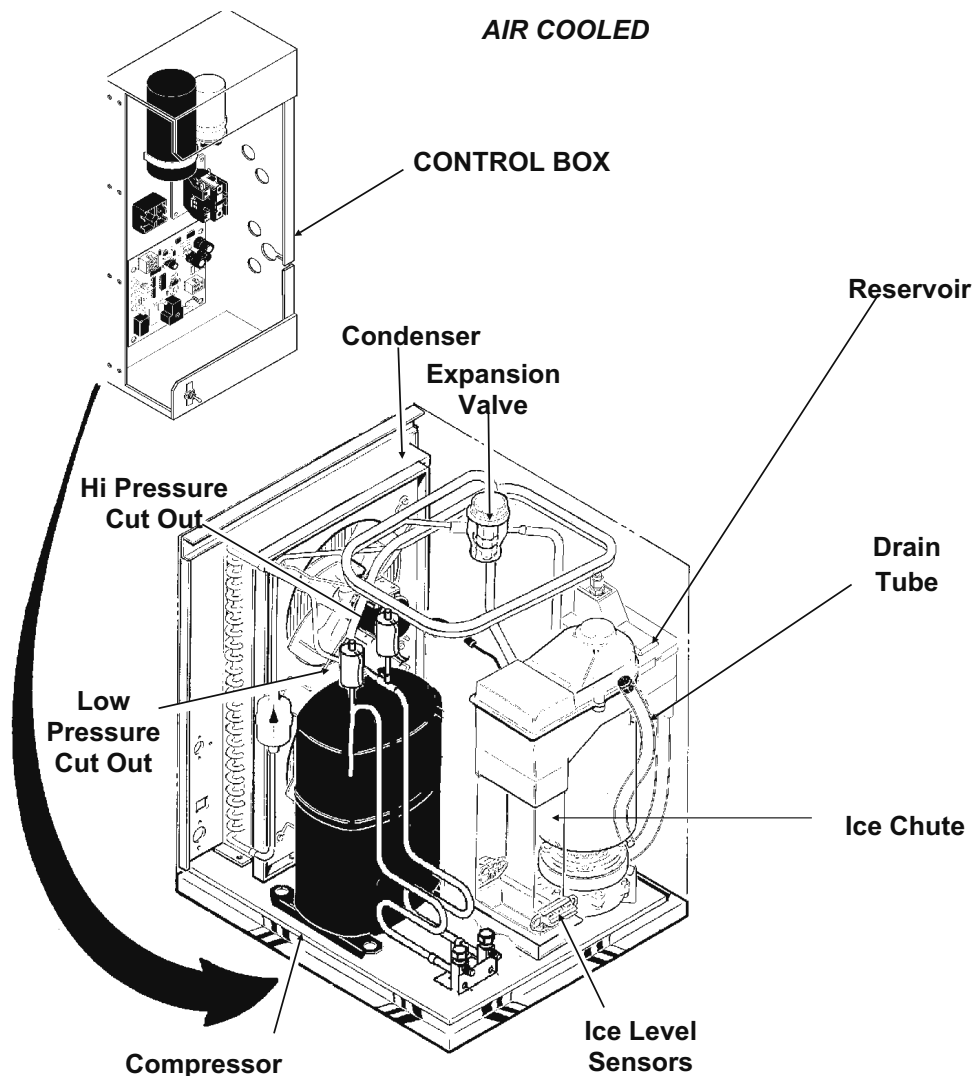

COMPONENT DESCRIPTION

Evaporator: A refrigerated vertical tube filled with water and containing a water seal and auger.

Auger: A solid stainless steel double spiral auger, it pushes the ice crystals up to the top of the evaporator.

Water Seal: A two part "face" seal, the top half rotating with the auger, the bottom half stationary, the sealing action being where the two seal "faces" meet.

Ice Sweep: A plastic cap with "fingers". It revolves with the auger to "sweep" the ice into the ice chute.

Breaker (Divider): Where the ice is compressed and much of the extra water is squeezed out of it before it is discharged into the bin.

Motor: A split phase motor that drives the gear reducer.

Thrust Bearing: As the ice is pushed up the evaporator, the auger is thrust down, and pressure from the auger thrust is taken up by this bearing.

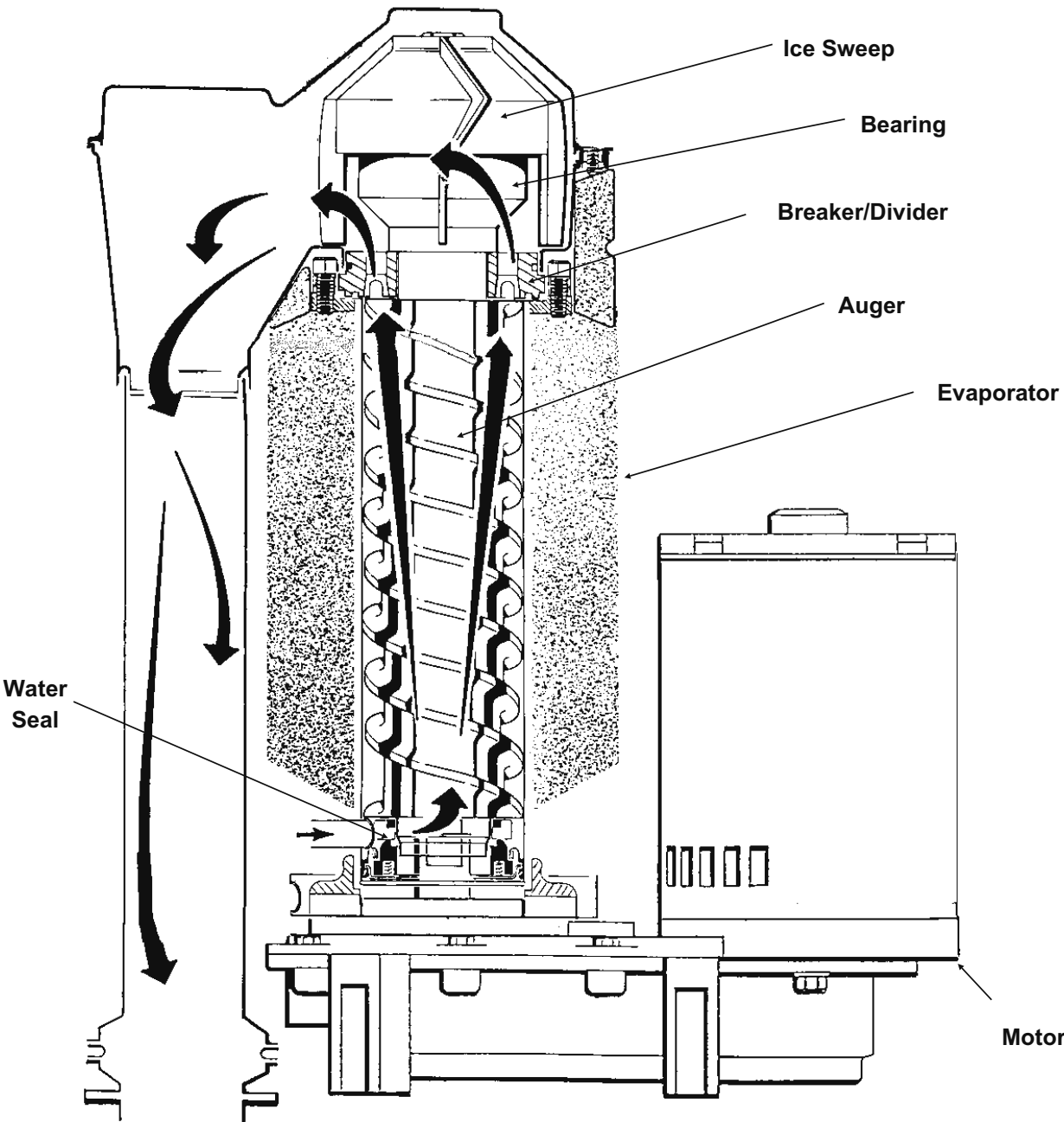

NME954 & FME1204

CONTROL BOX: Components

Contactor: A definite purpose contactor connecting the compressor and the fan motor to the power supply.

Circuit Board: Controls the operation of the ice machine using input from sensors and pressure controls. Switches loads on and off thru relays. See photo below.

Potential Relay: The compressor start relay.

Mode (On/Off) Switch: Manual control for the machine.

Control Board

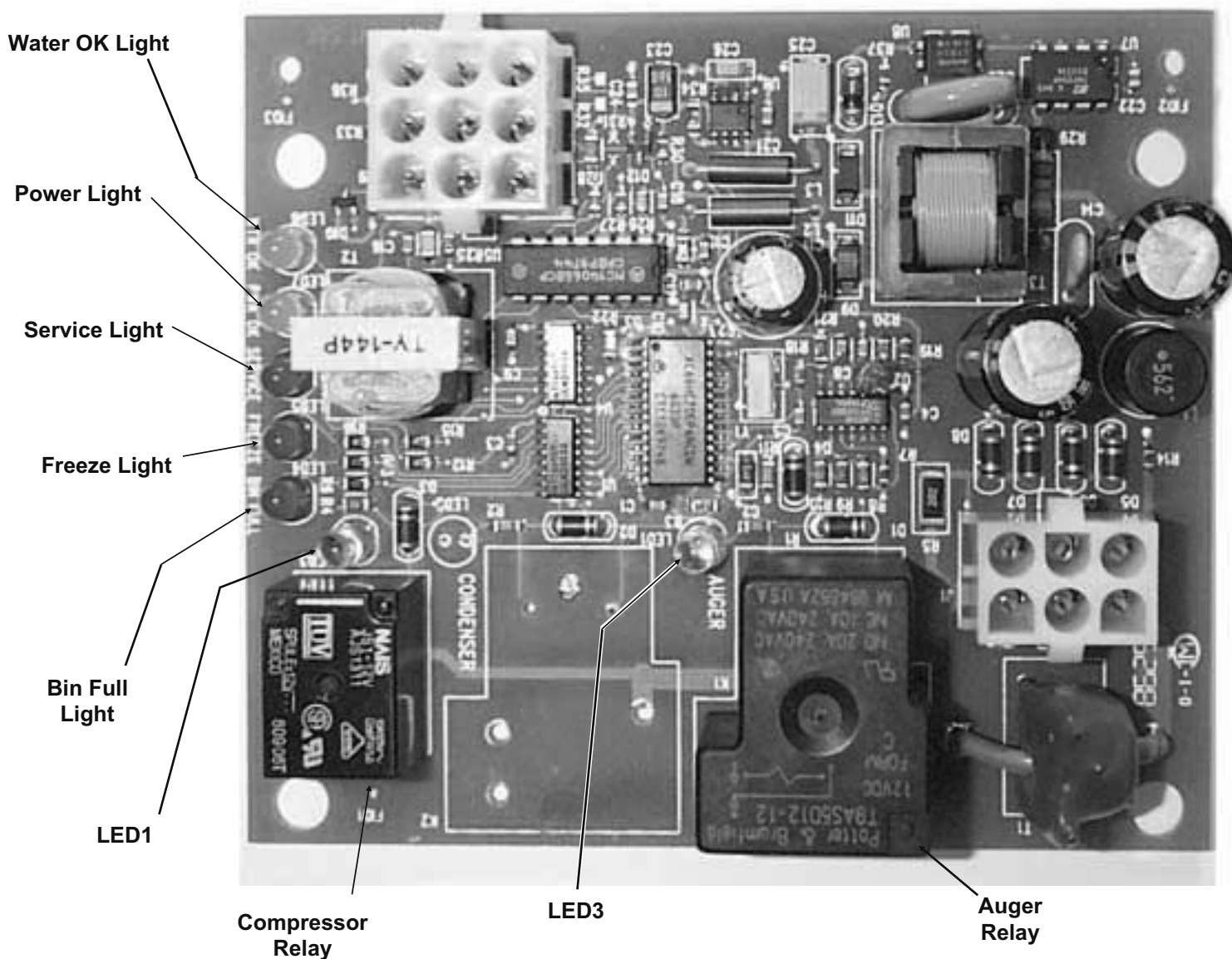

ELECTRICAL SEQUENCE:

There are 7 indicator lights on the control board:

- **WTR-OK** (Water OK). *Green. Normal = Glowing. Glows when there is water in the reservoir.*
- **PWR-OK** (Power OK). *Green. Normal = Glowing. Glows when the control board has power and is functional.*
- **Service**. *Red. Normally Off.*
- **Freeze**. *Red. Normally glowing when making ice.*
- **Bin Full**. *Red. Normally Off when making ice.*
- **LED1**. *White. Located next to the board's Compressor Relay. Normally Glowing when making ice.*
- **LED3**. *White. Located next to the board's Auger Motor Relay. Normally Glowing when making ice.*

If the machine is switched off at the mode switch, but is otherwise ready to go, switching the mode switch to ON does the following:

- The PWR-OK light glows.
- If there is water in the reservoir the WTR-OK light glows.
- After 10 seconds the Freeze, LED1 and LED3 lights glow and the machine starts up.

Start Up:

- The compressor relay and auger motor relay become energized, connecting power to the windings of the auger motor and contactor coil.
- The contactor is energized, connecting power to the compressor, and the compressor starts.
- As ice is made it passes between the ice level sensors but because it is not a continuous stream it only interrupts the sensor's infrared beam momentarily. The bin full light remains off and the machine stays on until ice builds up in the bin and blocks the path between the sensors for 6 seconds or longer. When that occurs the bin full light glows and the machine shuts down.

Shut Down:

- The compressor relay opens, LED1 goes out.
- The compressor contactor opens
- The compressor stops
- The auger motor stays on for 1 more minute, clearing out ice in the evaporator, and then
- The auger motor relay opens, LED3 goes out and the auger motor stops.

The compressor will not restart until 2 minutes or more have passed after the last shut down.

If the path between the ice level sensors remains clear for more than 10 seconds the ice machine will restart.

Control Board Protection Devices

- When the water level in the reservoir falls below the water level sensor's tip, the WTR-OK light goes out and the machine shuts down. When water refills the reservoir the WTR-OK light glows and the machine starts up again.
- If the auger drive motor current becomes excessive the compressor and auger drive motor will be switched Off and the Service light will blink. The control board will restart the auger drive motor in 4 minutes. If during the first 60 seconds after restart the auger motor current stays within limits, the compressor is restarted and the machine returns to normal operation. If the auger motor's current is excessive within 60 seconds after the restart, the process will be repeated once more. If during that try the current is still excessive the machine shuts down and must be manually reset. The service light will then be glowing continuously.

To Reset: Switch power to the unit off and then on.

Other Protection Devices:

- If the **high pressure** cut out switch opens the machine will stop immediately. It will automatically reset when the high pressure falls below its cut in point.
- If the **low pressure** cut out switch opens the machine will stop immediately. It will automatically reset when the pressure rises above its cut in point.
- The **mode (on - off)** switch is the manual control for the complete machine, but it is not a service disconnect.

NME954 & FME1204

OPERATION: Water

Water enters the machine through the 3/8" male flare at the rear of the cabinet, goes to the water reservoir which it enters through the float valve. The water then goes out the bottom of the reservoir tank to the bottom of the evaporator. Reservoir overflow or evaporator condensation is routed to the drain. Water cooled models have a separate water circuit for the cooling water: it

enters the fitting at the rear, goes to the water regulating valve, then to the water cooled condenser and down the drain.

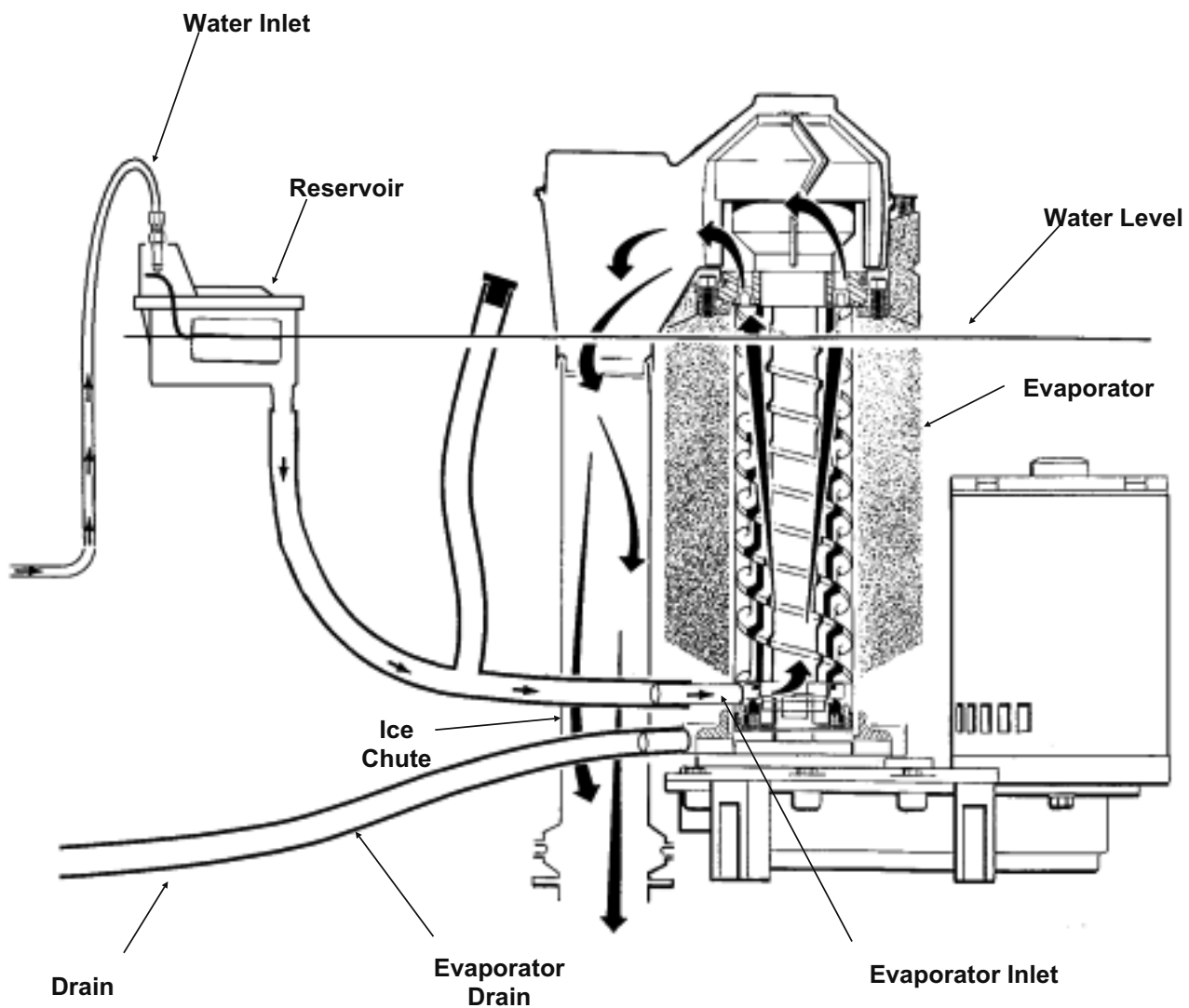

WATER SCHEMATIC

OPERATION: Performance

Typical Low Side Pressure

- Air Cooled: 34 - 38 PSIG
- Water Cooled: 32 PSIG

Typical Discharge Pressure

- Air Cooled: 220 - 275 PSIG
- Water Cooled: 245 PSIG

Typical Compressor Amp Draw

- Single phase = 4.3
- Three phase = 2.8

Superheat

- 5 - 7 degrees

High Pressure Cut Out (auto reset)

- 450 PSIG

Low Pressure Cut Out (auto reset)

- 15 PSIG

Refrigerant Charge

- Air Cooled: 30 ounces R-404A
- Water Cooled: 24 ounces R-404A

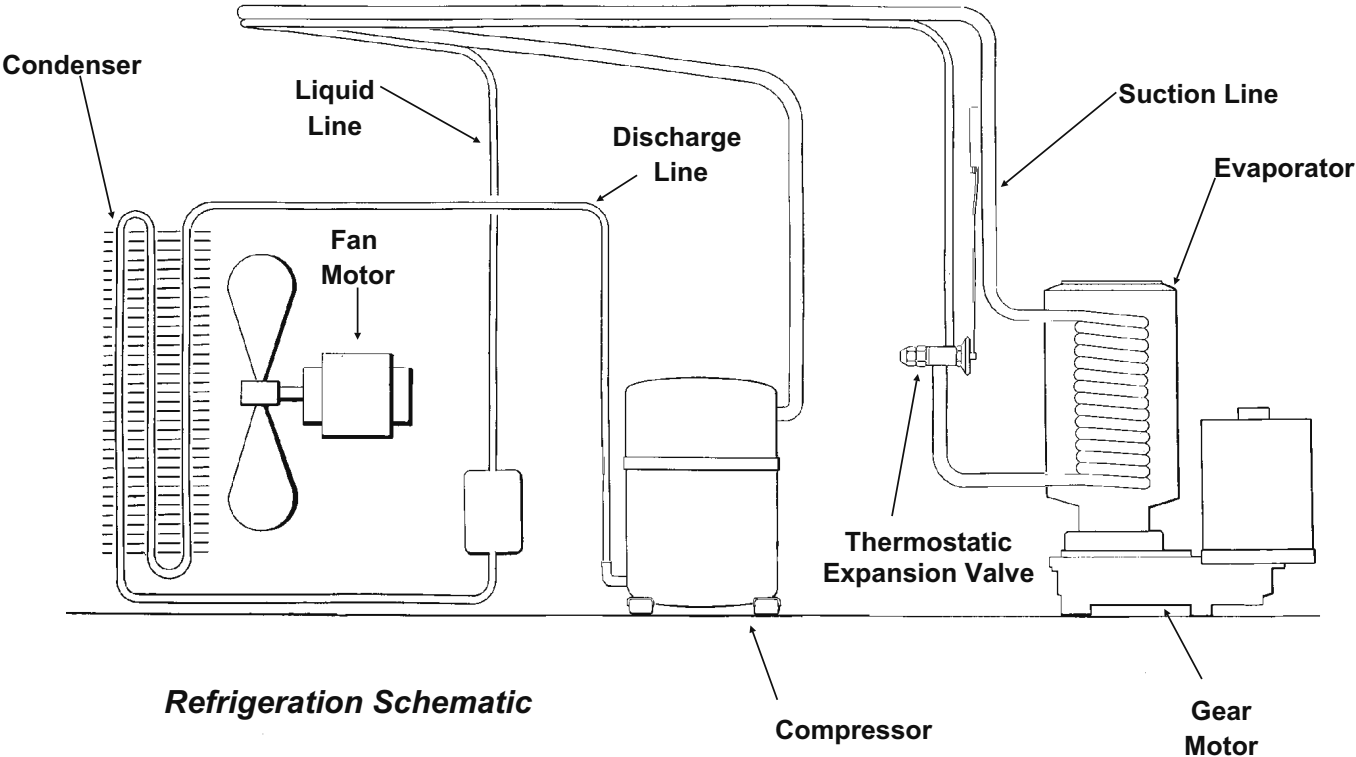

NME954 & FME1204

SANITIZING AND CLEANING

It is the USER'S RESPONSIBILITY to keep the ice machine and ice storage bin in a sanitary condition. Without human intervention, sanitation will not be maintained. Ice machines also require occasional cleaning of their water systems with a specifically designed chemical. That chemical dissolves mineral build up that forms during the ice making process.

Sanitize the ice storage bin as frequently as local health cods require, and every time the ice machine is cleaned and sanitized.

Maintenance and Cleaning should be scheduled at a minimum of twice per year.

ICE MAKING SYSTEM: In place cleaning

1. Check and clean any water treatment devices, if any are installed.
2. Remove screws, and the front and top panels.
3. Move the ON-OFF switch to OFF.
4. Remove all the ice from the storage bin.
5. Remove the cover to the water reservoir and block the float up.
6. Drain the water reservoir and freezer assembly using the drain tube attached to the freezer water inlet. Return the drain tube to its normal upright position and replace the end cap.
7. Prepare the cleaning solution: Mix eight ounces of Scotsman Ice Machine Cleaner with three quarts of hot water. The water should be between 90-115 degrees F.

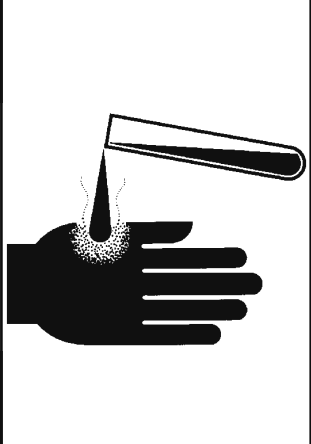
	⚠ WARNING
	Scotsman Ice Machine Cleaner contains acids. These compounds may cause burns. If swallowed, DO NOT induce vomiting. Give large amounts of water or milk. Call Physician immediately. In case of external contact, flush with water. Keep out of the reach of children.

8. Slowly pour the cleaning solution into the water reservoir until it is full. Wait 15 minutes, then switch the master switch to ON.
9. As the Ice Machine begins to use water from the reservoir, continue to add more cleaning solution to maintain a full reservoir.
10. After all of the cleaning solution has been added to the reservoir, and the reservoir is nearly empty, switch the master switch to OFF.
11. After draining the reservoir, as in step 6, wash and rinse the water reservoir.

12. Go thru steps 13-18 to sanitize the ice machine water system.

13. Mix two gallons of sanitizer solution. Use an approved sanitizer.

A possible sanitizer solution may be obtained by mixing two gallons of warm (90-115°F.) potable water with 1 ounce of household bleach.

14. Slowly pour the sanitizer solution into the water reservoir until the float rises, then switch the master switch ON.

15. As the ice machine uses water from the reservoir, continue to pour the sanitizer solution into the reservoir.

16. After ½ of the sanitizer solution has been added to the reservoir, and the reservoir is nearly empty, switch the master switch OFF.

17. Drain the reservoir and thoroughly wash the interior of the reservoir and cover with sanitizer solution.

18. Remove the block from the float in the water reservoir.

19. Switch the master switch to ON

20. Continue ice making for at least 15 minutes, to flush out any cleaning solution. Switch the master switch OFF.

DO NOT USE any ice produced from the cleaning solution.

Be sure no ice remains in the bin.

21. Remove all ice from the storage bin.

22. Add warm water to the ice storage bin and thoroughly wash and rinse all surfaces within the bin.

23. Sanitize the bin interior by thoroughly washing the interior of the bin and bin door with the balance of the sanitizer solution.

24. Switch the master switch ON.

25. Replace the panels.

SENSOR MAINTENANCE

1. The bin control uses devices that sense light, therefore they must be kept clean enough so that they can “see”. At least twice a year, remove the bin control sensors from the base of the ice chute, and wipe the inside clean, as illustrated.

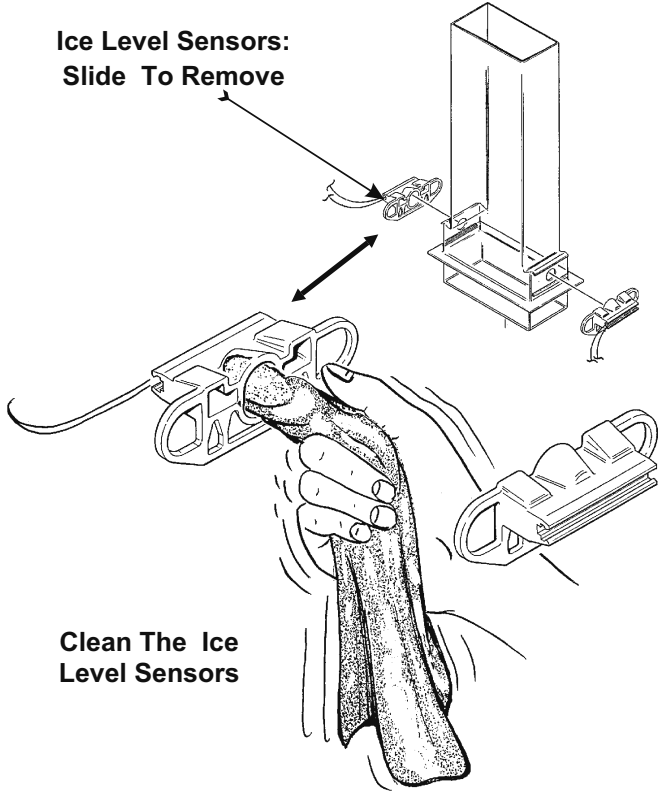

2. The ice machine uses a probe in the reservoir to determine if there is water.

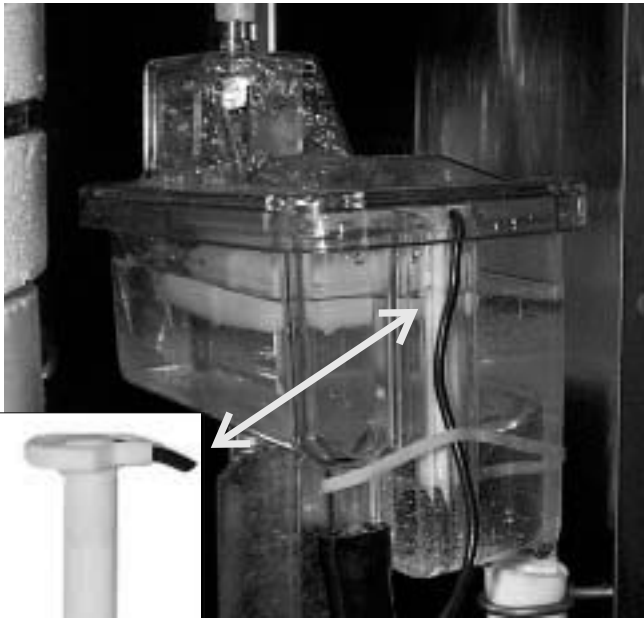

At least twice a year remove the probe from the reservoir and wipe the tip clean of mineral build-up.

Clean the Probe's Tip with ice machine cleaner and a clean, soft cloth.

NME954 & FME1204

BEARING MAINTENANCE

The bearing in the breaker should also be checked at least **two times per year**.

Switch the machine Off and check the bearing:

- removing the ice chute cover

Chute Cover



- unscrewing the ice sweep

Ice Sweep



- removing the water shed & unscrewing the breaker cover (left hand threads).

Breaker Cover

Off

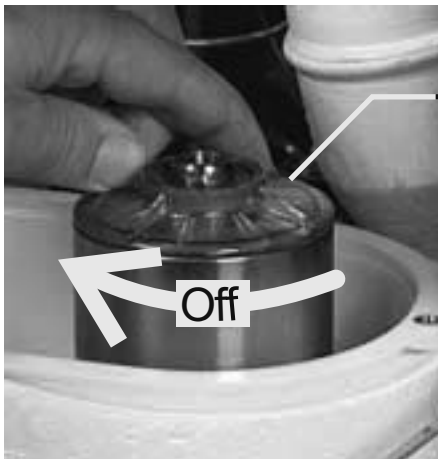

- unscrewing the auger stud

Auger Stud

Cap Screw



Inspect the bearing. There should be plenty of grease in sight. If grease is needed the bearing and breaker should be removed to check the action of the bearing. It should rotate smoothly.

To remove the breaker remove the lower ice chute then take out all four allen head cap screws and pull the breaker off the auger and evaporator.

If the bearing only needs grease, inject grease into the bearing using Scotsman grease needle pn 02-3559-01 and Scotsman bearing grease cartridge, pn A36808-001. Be sure to inject grease evenly and thoroughly.

Bearing

Needle, pn 02-3559-01



See Removal and Replacement section to replace bearing or seals.

Reverse to reassemble.

MAINTENANCE: Air Cooled

Clean or replace the air filter.



REMOVE TWO SCREWS & UNPLUG FAN MOTORS.

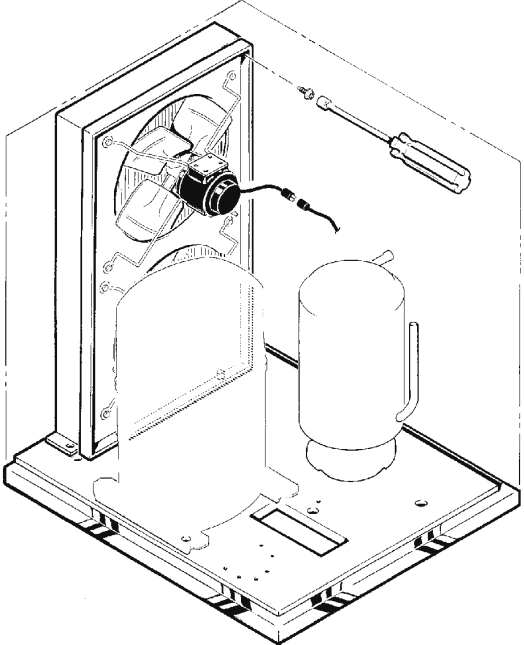

PULL FAN MOTOR ASSEMBLY UP AND TO THE RIGHT TO REMOVE

Clean the air cooled condenser.
Air flow on this model is from front to back, so the inside of the machine will have to be available to clean the air cooled condenser. Use a vacuum cleaner or coil cleaner if needed. Do NOT use a wire brush.

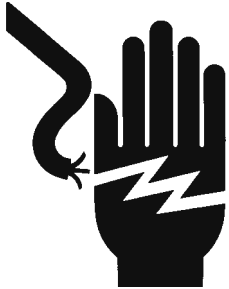
	<p>⚠ WARNING</p> <p>Electrical shock hazard. Electrical shock can cause personal injury. Disconnect power before beginning to service components.</p>
---	---

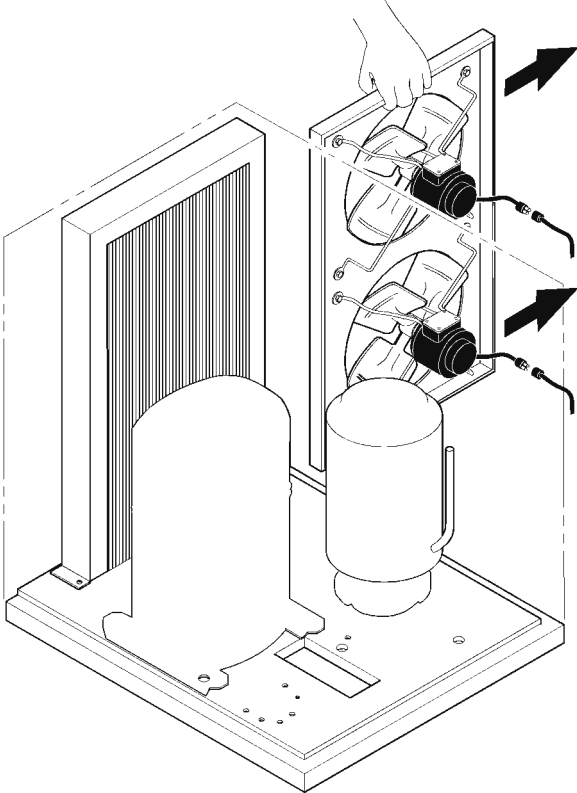

- A. Disconnect electrical power, and remove the filter. The filter may be cleaned or replaced.
- B. Clean the condenser: the condenser may appear to be clean on the surface, but it can still be clogged internally. Check with a flash light from the front to see if light can be seen though the condenser fins. Reverse to reassemble.

NME954 & FME1204 AUGER MAINTENANCE

In some areas, the water supply to the Ice Machine will contain a high concentration of minerals, and that will result in an evaporator and auger becoming coated with these minerals, requiring a more frequent removal than twice per year. If in doubt about the condition of the evaporator and auger, the auger can be removed so the parts can be inspected.

Note: Water filters can filter out suspended solids, but not dissolved solids. "Soft" water may not be the complete answer. Check with a water treatment specialist regarding water treatment.

For more information on removal of these parts, see REMOVAL AND REPLACEMENT.

	⚠ WARNING
	Moving parts hazard. Moving parts can cause personal injury. Disconnect power before beginning to service components.

Turn off the water supply.

1. To remove the auger, remove the front and top panels.
2. Push back bail clamp holding ice chute cover to ice chute, and remove cover.
3. Unscrew and remove ice sweep.
4. Remove ice chute from evaporator.
5. Remove 4 allen screws holding breaker to evaporator.
6. Drain the evaporator by lowering and uncapping the evaporator drain hose.
7. Pull up to remove auger.

After the auger has been removed, allow the auger to dry: if the auger is not bright and shiny, it must be cleaned.

Clean the auger and evaporator as required. **DO NOT HONE THE EVAPORATOR.**

8. Replace the water seal.
9. Reverse to reassemble.

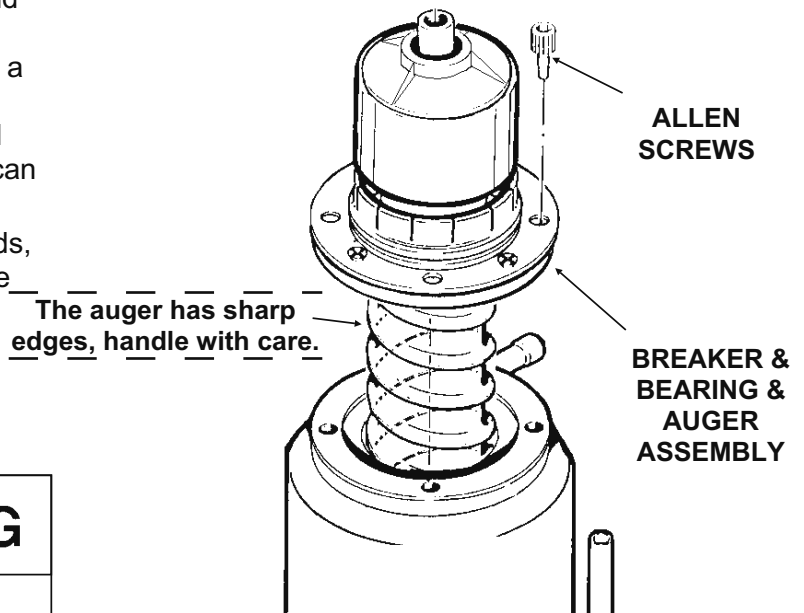

SERVICE DIAGNOSIS

Symptom	Possible Cause	Probable Correction	
No ice is made, nothing operates	Unit off due to no power	Restore Power	
	Unit off due to master switch in OFF position.	Switch master switch to ON.	
	Unit off due to low water level.	Check water supply, filter, strainer, float valve. Correct water supply.	
	Unit off due to ice level sensors (photo-electric eyes) blocked.	Check/clean ice level sensors.	
	Unit off due to scale on water level sensor.	Clean water level sensor.	
	Unit off due to high pressure control open.	Check for water interruption (water cooled) or fan motor failure (air cooled).	
	Auger motor hums but does not turn.	Auger can't turn. Circuit board has not yet shut unit down.	
	Unit is shut down	Circuit board has shut ice machine down due to high auger motor amp draw. Check for cause of high amp draw, including bearings, gearmotor condition and scale on auger and in evaporator.	
	Low pressure control open		Auger not turning due to: motor failure; auger relay failure on circuit board; or gears stripped. Check drive train.
			TXV restricted or not metering. Check bulb temperature.
			Lack of refrigerant. Check for leak.
			Check for a restricted system
	No power to circuit board.		Low pressure control open. See above
			High pressure control open. Fan motor failure (a/c) or water shut off (w/c)
Check harness			
Circuit Board gear motor relay will not close		Check, replace board	
Water level or ice level sensor failed.		Check, replace sensor	
No ice, auger motor is turning	Compressor contactor coil is open	Check/replace contactor	
	Compressor will not start	Check start capacitor.	
		Check start relay	
		Check compressor windings	
Circuit board compressor relay will not close.		Check, replace board	

NME954 & FME1204

SERVICE DIAGNOSIS

Symptom	Possible Cause	Probable Correction
Water Leak	Drain plugged up	Clean out drain
	Tubing cracked	Replace tubing
	Condensation on drain tubing	Insulate tubing
	Hose off	Reattach hose
	Reservoir cover off	Return cover to reservoir
	Reservoir cracked	Replace reservoir
	Evaporator water seal leaks	Check base of evaporator & drip pan. If the seal leaks, shut off the water, remove the auger, replace the water seal. Check gear motor for water infiltration.
Excessive water use	Water cooled model, water regulating valve not adjusted properly.	Adjust to 245 PSIG discharge pressure
	Reservoir float valve leaks thru	Replace float valve or seat
	Water cooled model, overcharged with refrigerant	Recover and weigh refrigerant. Weigh in correct charge.
	Water cooled model, condenser coated with minerals	Acid clean water cooled condenser.
Excessive ice meltage	Bin drain clogged	Clean out bin drain.
	Improper installation of drains, they are connected.	Drains must be separate.
	Poor fit between bin door and door frame	Adjust or replace
Machine makes too much noise	Evaporator coated internally with minerals	Clean with Scotsman Ice Machine Cleaner
	Motor bearings dry	Oil or replace motor

CONTROL SYSTEM DIAGNOSTICS

The control system consists of:

- Control Board
- Water Sensor
- Ice Sensors
- High Pressure Cut Out
- Low Pressure Cut Out

If the unit is OFF, check the **control board**:

1. Is the Power OK light on? If not check power to the unit. If it has power, and the Power OK light is NOT on, check the high pressure and low pressure cut outs. If they are both closed, replace the board. If the Power OK light is ON, go to the next step.

2. Is the Water OK light on? If it is, go to the next step. If not, check the water level in the reservoir. If there is water in the reservoir, check that the water sensor is plugged in. To check the **water sensor**:

A. Unplug water sensor.

B. Pull water sensor from reservoir.

C. Place one ohmmeter lead on the sensor's plug and the other on the sensor's tip. The meter should show nearly zero resistance. If it reads infinite resistance, check the tip for corrosion. If it is clean and still reads open, replace the sensor.

OR connect a copper wire to the wire where the water sensor plugs into and place the other end in the water. The water OK light should go ON. If it does not, replace the control board.

3. **Ice sensor check.** Is the Bin Full light Off? If it is OFF and the Service light is Off, and the unit is not running, replace the control board.

If it is OFF and the auger motor is running but the compressor is not, check the compressor contactor coil.

If it is on, the ice sensors may be blocked. Remove them and check for mineral scale. Scotsman's test box can also be used to determine if the ice sensors or board are defective.

Using the tester:

A. Disconnect the ice sensors at the connection by the ice chute. Connect the LED and PHOTO TRANS wires to the control board's wires.

B. With the On - Off (mode) switch in either position, move the Bin Full switch on the tester to Bin Full - the tester's light will blink and after a few seconds the bin full light on the control board will come on. If not, replace the board.

Move the Bin switch on the tester to Bin Empty. The light on the tester will go out, and after a few

seconds the Bin Full light on the board will go out. If master switch is ON, the unit should start.

4. **High pressure** cut out check.

Disconnect electrical power.

Pull the wires off the high pressure cut out.

Use an ohmmeter to determine if the switch is OPEN, If it is, check the discharge pressure. If the discharge pressure is less than 300 PSIG, replace the high pressure cut out.

If the high pressure cut out is open and the system has high discharge pressure, check for the cause.

5. **Low pressure** cut out check.

Disconnect electrical power.

Pull the wires off the low pressure cut out.

Use an ohmmeter to determine if the switch is OPEN, If it is, check the suction pressure. If the suction pressure is greater than 20 PSIG, replace the low pressure cut out.

If the low pressure cut out is open and the system has low suction pressure, check for the cause.

NME954 & FME1204

REMOVAL AND REPLACEMENT: Water Reservoir & Bin Controls

WATER RESERVOIR

1. Shut off the water supply to the ice maker.
 2. Remove front panel.
 3. Remove reservoir cover.
 4. Disconnect water inlet tube from reservoir inlet fitting.
 5. To remove float valve, push in "locking tabs" as shown and pull float up.
- Note: The plunger/seat is available separately as a part.
6. To remove reservoir, pull up and remove water sensor.
 8. Disconnect water outlet tubes.
 9. Remove mounting screws from reservoir bracket, and remove reservoir from ice maker.
 10. Reverse to reassemble.

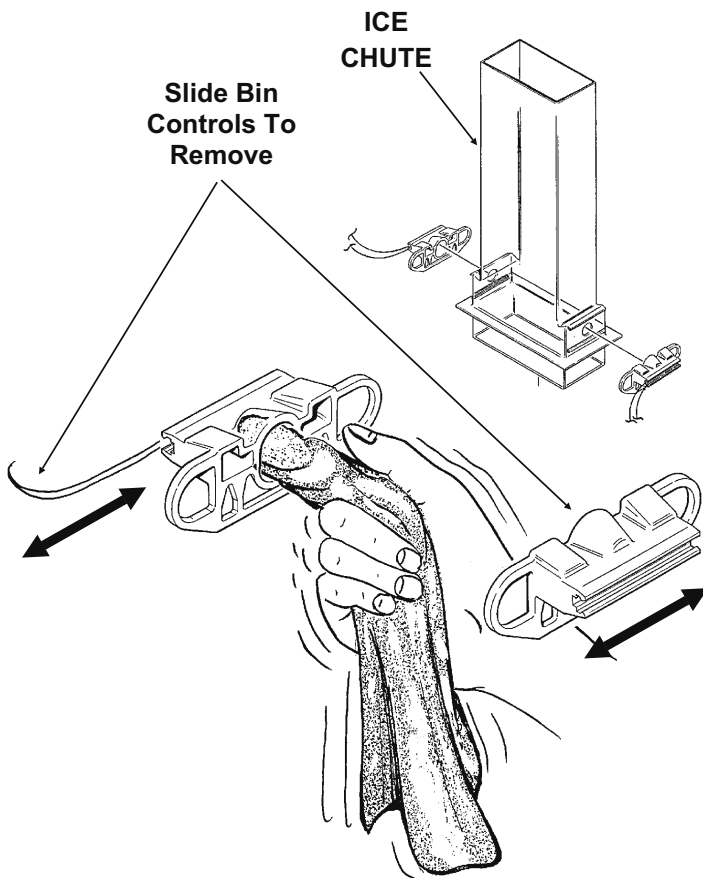
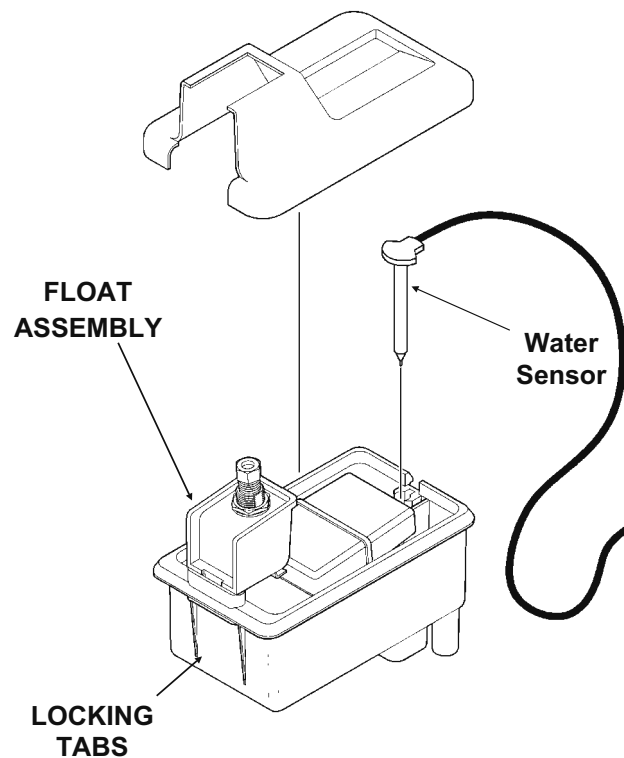

BIN CONTROLS (Ice Level Sensors)

1. Disconnect electrical power.
2. Remove front panel.
3. Remove control box cover.
4. Locate ice chute, at the base of the chute, in front of and behind it are two plastic bin control mounts.
5. Slide each bin control to the left, and disconnect the electrical leads connecting the bin control to the circuit board.
6. Reverse to reassemble, be certain that the bin controls are aligned so that the ice level sensors are visible (centered) through the holes in the ice chute.

REMOVAL AND REPLACEMENT: Bearing And Breaker

Note: Removal of the auger, water seal, evaporator and gear motor must begin at the top of the assembly.

1. Remove panels and disconnect electrical power.

	<p>⚠ WARNING</p> <p>Electrical shock hazard. Electrical shock can cause personal injury. Disconnect power before beginning to service components.</p>
---	---

2. Push back bail clamp and remove ice chute cover.

3. Unscrew and remove ice sweep.

4. Lift up and remove ice chute.

5. The breaker may be removed from the auger and evaporator without disturbing the auger.

a. Unscrew breaker cover from breaker (left hand threads)

b. Unscrew auger stud from top of auger.

c. Unscrew 4 allen head cap screws holding breaker to evaporator.

d. Lift up, and remove breaker/bearing assembly from auger & evaporator.

6. Service the bearing. Check for rust, rough spots and damage.

a. The bearing is pressed into the breaker, to remove the bearing and replace it an arbor press is needed.

b. Replace lower seals before installing new bearing in breaker.

Note: seals must be pressed in with a tool pushing against the outer edge only, they will not install by hand.

Replace parts as required. Re-grease bearing with Scotsman part no. A36808-001 bearing grease. Replace top seal, and check the o-rings, replace if cut or torn.

7. Reverse to reassemble: specific tools and materials are required to install properly.

a. Add food grade grease such as Scotsman part number 19-0569-01 to the seal area before installing on the auger.

b. Check the seal to shaft areas for cuts, or rough spots: none are permitted.

Note: Flaker parts are shown in this manual. Nugget Breakers do NOT have a Slotted Collar.

Step 5-a

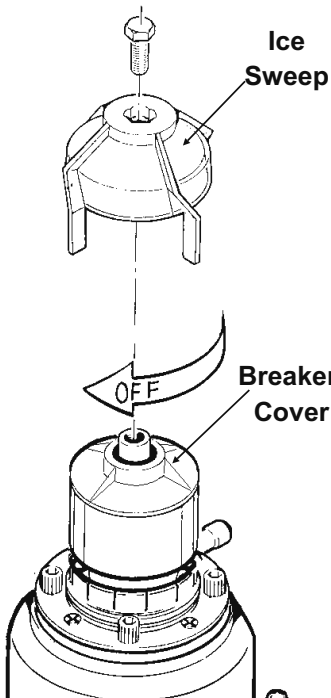

Step 5-b

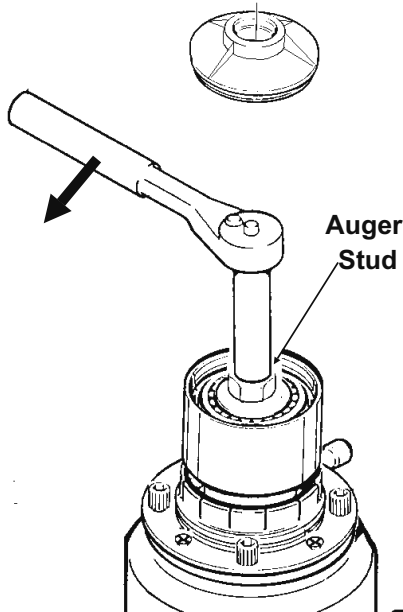

Step 5-c and Step 6

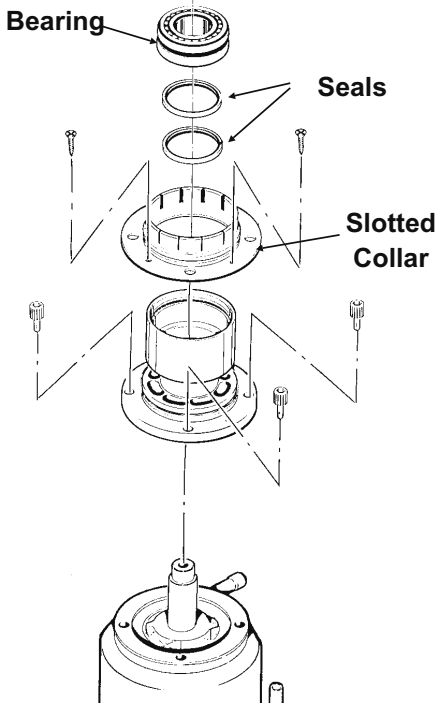

NME954 & FME1204

REMOVAL AND REPLACEMENT: Auger

To Remove the Auger:

Turn off the water to the machine, and unclip the evaporator drain hose, pull it down and drain the evaporator into the bin or a container.

1. Remove the top panel.

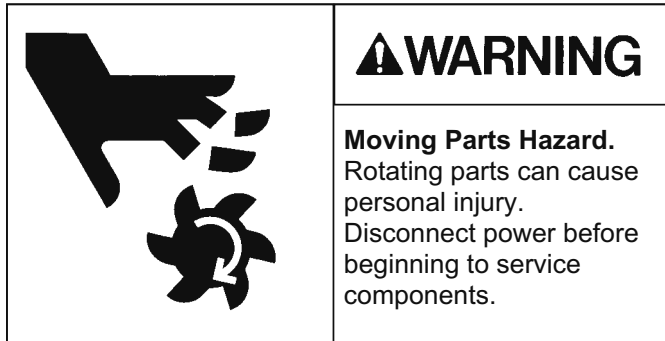

2. Swing bail clip down and remove ice chute cover.

3. Unscrew ice sweep.

4. Remove ice chute body.

5. The auger and breaker/bearing may now be removed as an assembly.

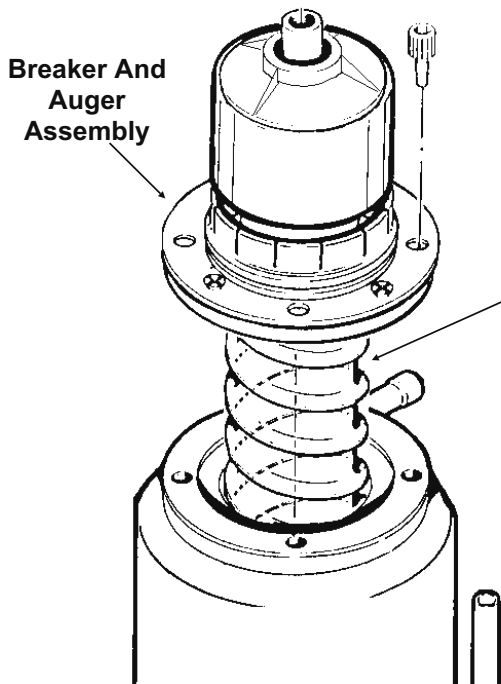

a. Unscrew 4 allen head cap screws holding breaker to evaporator.

b. Lift up on breaker and remove auger from evaporator.

Note: If the auger is stuck, the breaker must be removed from the auger.

The breaker may be removed from the auger and evaporator without disturbing the auger.

a. Unscrew breaker cover from breaker (left hand threads)

b. Unscrew auger stud from top of auger.

c. Unscrew 4 allen head cap screws holding breaker to evaporator.

d. Lift up & remove breaker from evaporator.

e. If the auger is stuck use a slide hammer type puller to pull on the auger at the threaded hole. The size of that hole is 5/8"-18.

Inspect the auger, the critical areas of the auger are:

1. The auger body. It should be clean and shining. Sometimes an auger will appear clean when wet, but after it is dry it will be seen to be stained. Scrub the auger with ice machine cleaner and hot water.

WARNING
Ice machine cleaner is an acid. Handle it with extreme care, keep out of the reach of children.

2. The water seal area. Because the auger has been removed, the water seal will have to be replaced. Remove the water seal top half from the auger, and inspect the auger for minerals, clean as required.

WARNING
The auger has sharp edges, handle with care.

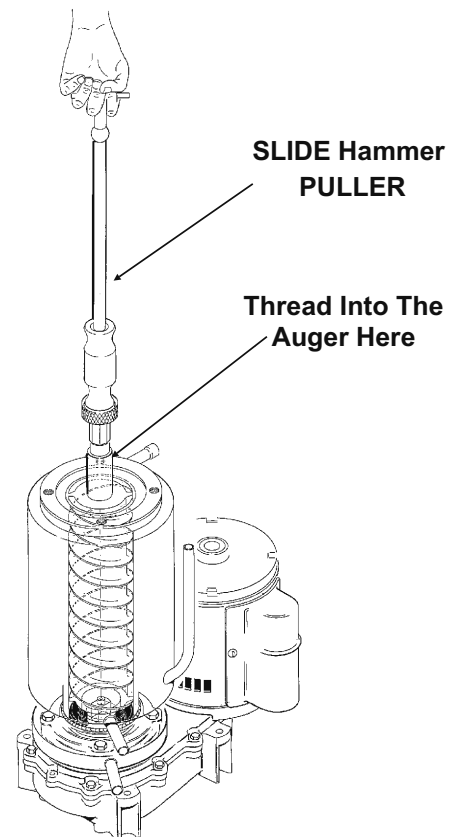

REMOVAL AND REPLACEMENT: Water Seal

To Remove the Water Seal:

(Assuming all steps to remove the auger have been performed.)

1. The gear motor/evaporator assembly will have to be exposed.
2. Remove the 4 hex head cap screws holding the evaporator to the gear motor assembly. Lift the evaporator up and off of the gear motor.
3. Remove the snap ring or wire retainer from the groove under the water seal.
4. Pull or drive out the lower half of the water seal.

REMOVAL OF THE WATER SEAL

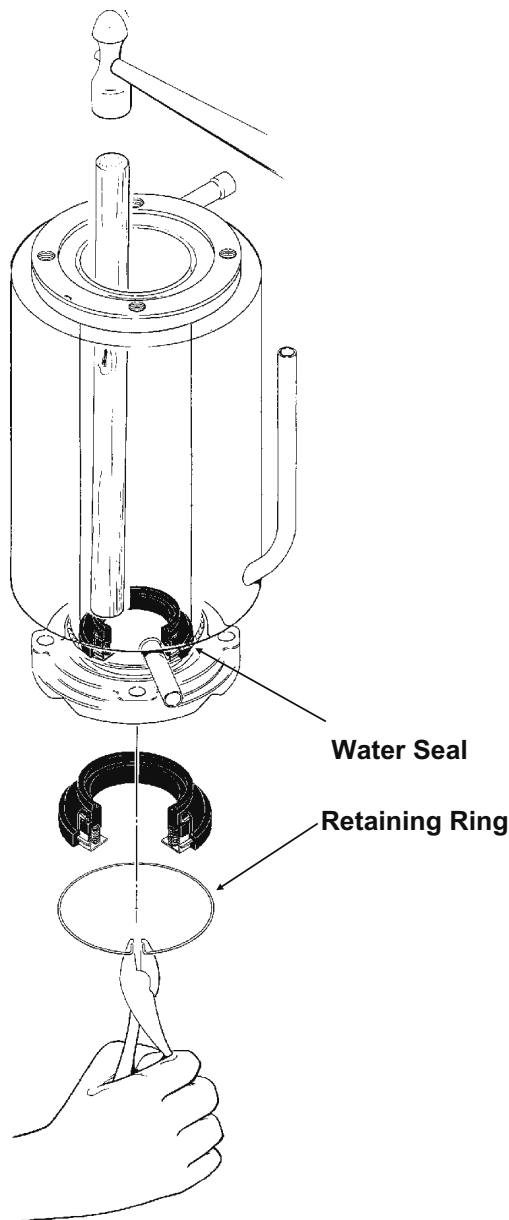

To Replace the Water Seal:

1. Lubricate the water seal with water, and push the water seal into the bottom of the evaporator slightly past the groove for the snap ring.
2. Replace the snap ring and pull the water seal down against it.
3. The part of the water seal that rotates with the auger must also be replaced. Remove the old part from the auger and clean the mounting area.
4. Place a small bead of food grade silastic sealant (such as 732 RTV or Scotsman part number 19-0529-01) on the area of the auger where the water seal is to be mounted.

REPLACING THE WATER SEAL

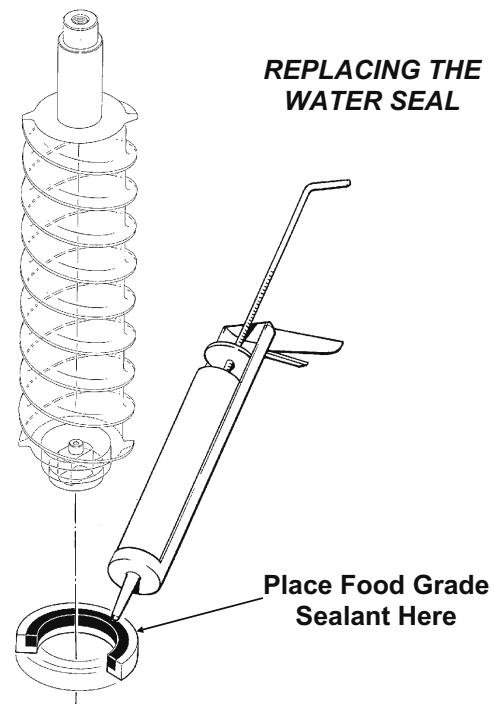

5. Carefully push the water seal (rubber side against the auger shoulder and the silastic.)

CAUTION

Do not get any silastic onto the face of the seal.

6. Allow the auger and seal to air dry until the silastic is dry on the surface.
7. If the original water seal was leaking, it would be a good idea to inspect the interior of the gear motor.

NME954 & FME1204

REMOVAL AND REPLACEMENT: Evaporator

To Replace the Evaporator:

(Assuming all the steps for removal of the thrust bearing, breaker, auger, and water seal have been performed.)

1. Recover the refrigerant from the Ice Machine.
2. Unsweat the refrigerant connections:

CAUTION

Heat sink the TXV body when unsweating or resweating the adjacent tubing.

- At the thermostatic expansion valve outlet.
- At the suction line at the joint about 3" from the evaporator.

3. Remove the evaporator.
4. Unsweat the drier from the liquid line.
5. After installing a new water seal in the new evaporator (see "To Replace the Water Seal") sweat in the new evaporator at the old tubing connections.
6. Install an new drier in the liquid line.
7. Evacuate the system until dehydrated, then weigh in the nameplate charge. Check for leaks.
8. Install auger, breaker, breaker bearing assembly, and ice discharge chute in reverse order of disassembly.

To Reassemble the Evaporator and Auger

1. After the gear motor has been inspected, fasten the evaporator to the gear motor. Torque the bolts to 110 inch pounds.
2. Lower the auger into the evaporator barrel, slightly turning it to match up with the drive end. Do Not Drop Into the Evaporator.
3. Complete the reassembly by reversing the disassembly for the breaker & thrust bearing assembly.

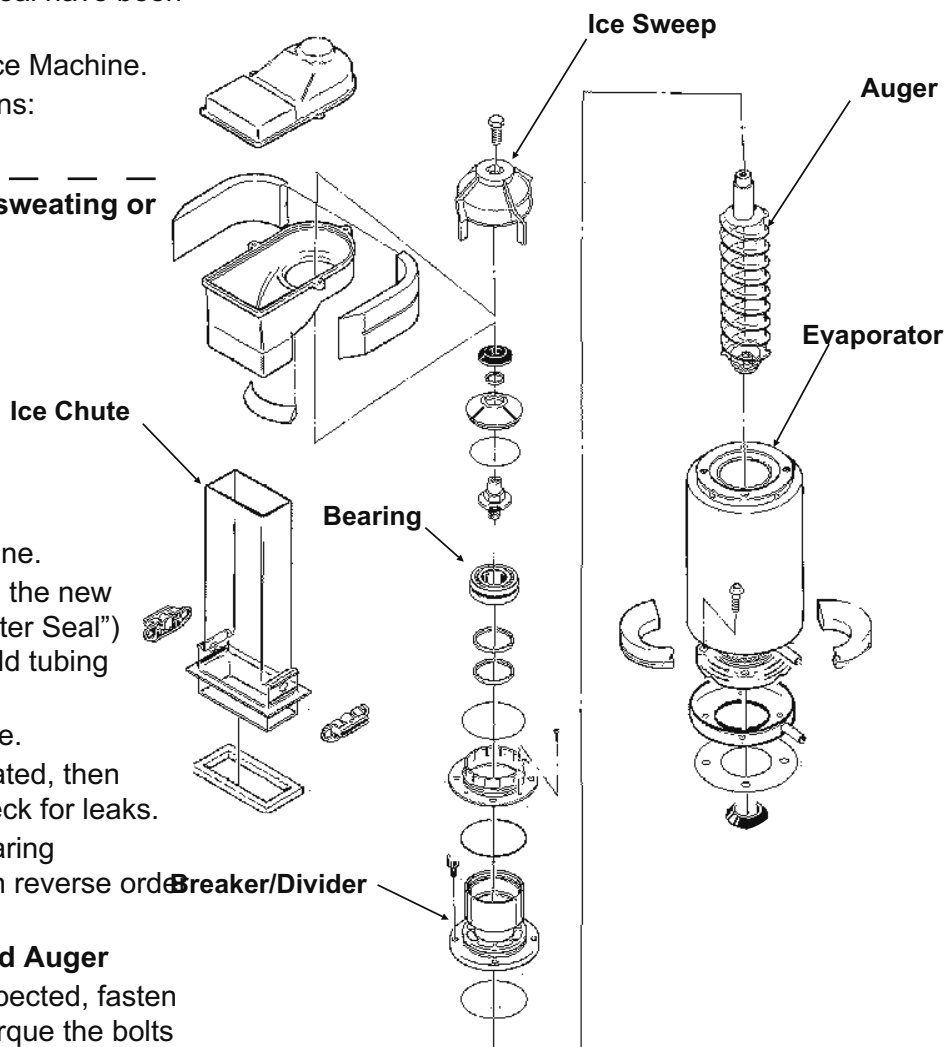

REMOVAL AND REPLACEMENT: Gearmotor

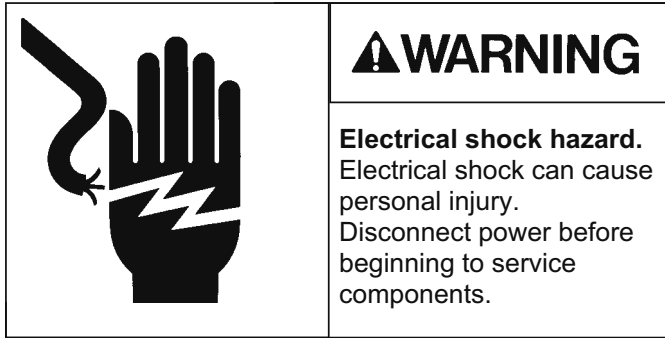

To Check the Motor:

1. Remove wires from terminals 1 and 2.
2. Use an ohmmeter to check for continuity. If there is none, replace the motor only. If there is continuity but the motor will not start, check the motor's start switch.
3. Remove motor end bell or motor stator. With ohmmeter wires attached to 1 and 2 move centrifugal switch actuator up and down to simulate motor rotation. If the ohmmeter does not show any change, replace the switch or motor. If the ohmmeter shows an open circuit, replace the switch or motor.

To Remove and Repair the Gear motor Assembly:

(Assuming that the procedures through removal of the water seal have been performed.)

1. Remove the electrical wires from the gear drive motor.
2. Unscrew the 4 cap screws holding the gear motor to the base of the machine.
3. Remove the gear motor from the Ice Machine.

Bench test the gear motor, check for oil leaks, noise, and amp draw.

To Inspect the gear motor.

- A) Remove the cap screws holding the gear motor case halves together and pry the two cases apart.
- B) To lift off the cover, lift up until you can feel internal contact, then pull the cover towards the output gear end, and then lift the cover (with drive motor attached) up and away from the gear motor case.

Note: The gearcase cover, output gear, bearings and output shaft are a pressed together assembly.

- C) Inspect the oil gears and bearings. If there is evidence of water in the oil (rusty metal, too much oil, white oil) replace the oil and damaged parts. The oil charge is 14 oz. Do not overfill.

Reassemble and bench test the gear motor, check for oil leaks, noise, and amp draw.

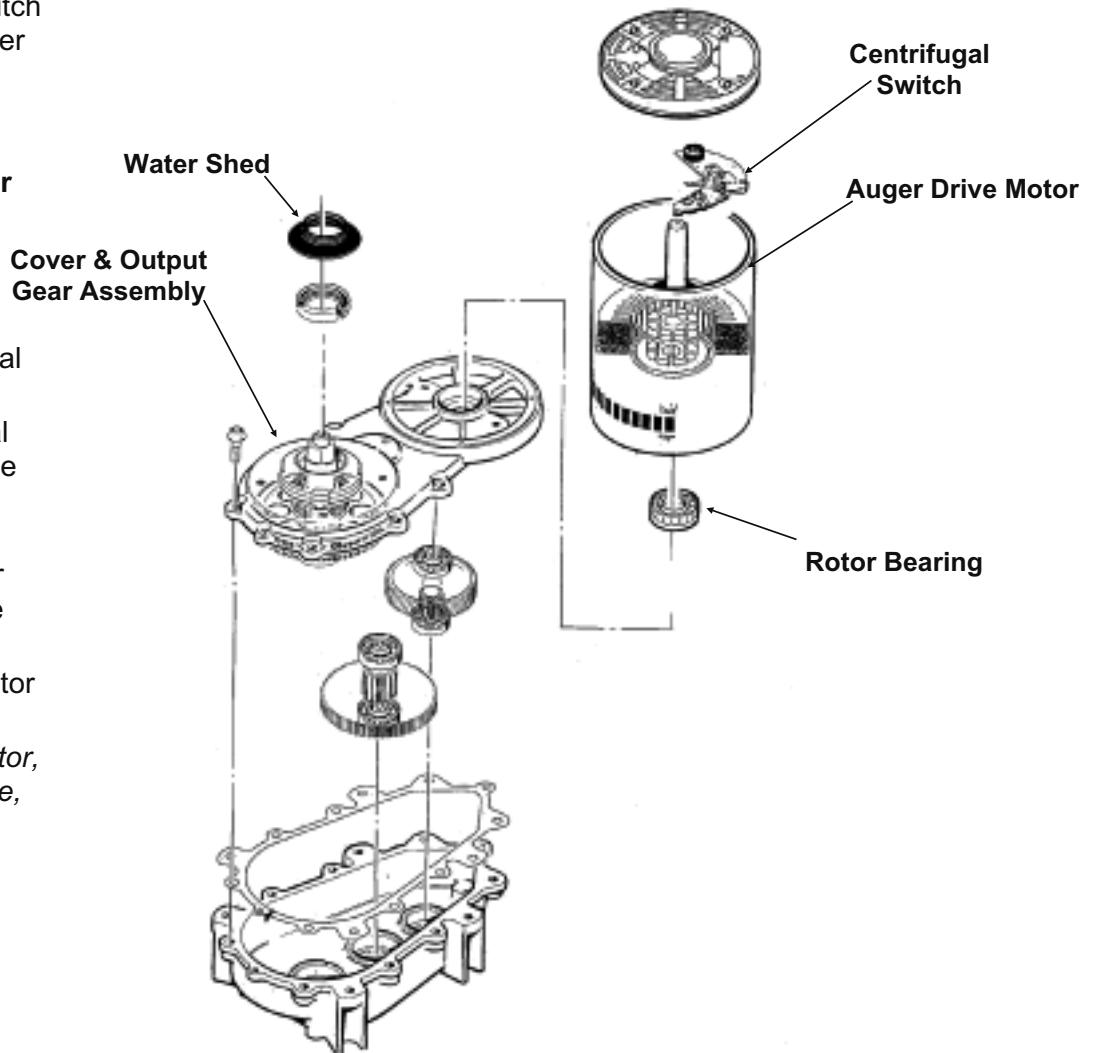

NME954 & FME1204

REMOVAL AND REPLACEMENT: Fan Blade and Motor

	<p>⚠ WARNING</p> <p>Electrical shock hazard. Electrical shock can cause personal injury. Disconnect power before beginning to service components.</p>
---	---

To Remove the Condenser Fan Motor Assembly

1. Remove top panel and the two service panels.
2. Unplug the two fan motor wire leads from the fan motors.
3. Remove the two hex head bolts from the top end of the fan motor assembly.

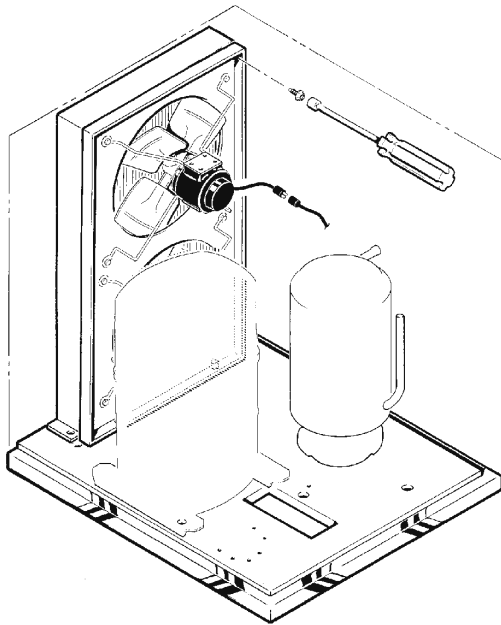

4. Lift up the fan motors and bracket assembly about 1/2" and pull out the fan motor assembly out the right

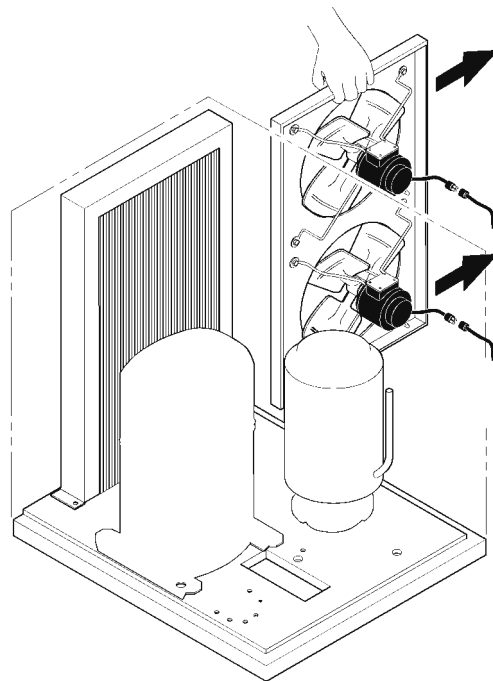

service access hole.

5. Repair as needed.

6. To reassemble: Place the fan motor assembly lower flange holes over the two allen head cap screws in the base, and reinstall the hex head bolts at the top of the assembly. Plug the fan motors back in, and replace the top panel.

REFRIGERATION SYSTEM SERVICE

General: This ice machine uses R-404A refrigerant and polyolester oil. Do NOT use mineral oil in this refrigeration system.

- When the system is serviced, a special liquid line drier is required. It is included with replacement compressors.
- R-404A is not compatible with mineral oil so these ice machines use Polyolester oil. Polyolester oil absorbs water very easily. A system opened for service must be re-sealed as soon as possible (15 minutes maximum).
- Special leak detection equipment is required to locate small refrigerant leaks. Usually a leak detector capable of detecting a Halogenated refrigerant or HFC-134a will work. Check with the leak detector manufacturer if in doubt.
- Evacuate to 300 microns.
- Liquid charge the system

Access Valves: To use the access valves:

- Remove the cap from the stem, use a 3/16" allen wrench to check that the valve is CLOSED. The remove the core cap.
- Close the valve and replace the caps when done. The valve must the caps

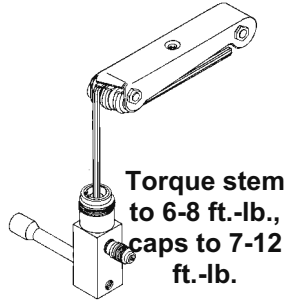

be closed and

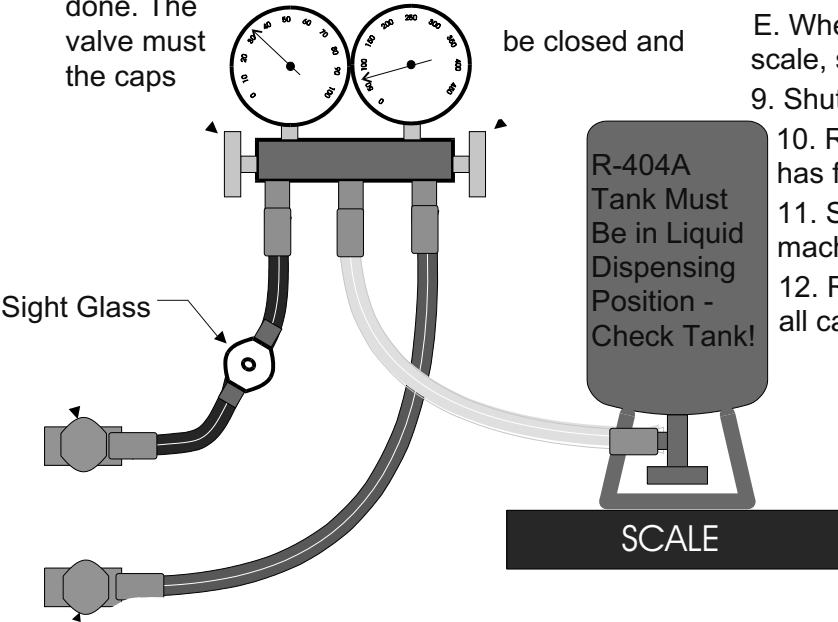

Hose Connection Schematic for Liquid Charging

Instructions for Liquid Charging R-404A

In preparation for charging, the low side hose should have a sight glass, and/or a restricting device (such as a "Charge Faster") installed in it for metering liquid into the low side of the system.

1. After a thorough evacuation shut off the manifold valves and switch off the vacuum pump.
2. Place a drum of R-404A onto an electronic scale.
3. Attach the charging hose to the drum.
4. Open the valve on the drum and purge the charging hose.
5. Zero out the scale.
6. Shut the low side access valve at the ice machine.
7. Open the discharge manifold valve full open.
8. Watch the scale, when the correct charge is shown, shut the manifold valve.

Note: If all of the charge will not "go in" the discharge side:

- A. Shut the discharge access valve at the ice machine.
 - B. Switch the machine on.
 - C. Open the low side access valve at the ice machine.
 - D. Open the low side manifold valve and observe the sight glass to be certain that only gas is flowing into the system.
 - E. When the proper charge is indicated on the scale, shut off the manifold valve(s).
9. Shut off the valve on the refrigerant drum.
 10. Re-open the manifold valves until all liquid has flowed out of the hoses.
 11. Shut the low side access valve on the ice machine.
 12. Remove hoses from ice machine and replace all caps.

NME954 & FME1204

What to Do Before Calling for Service

If the machine is off, not making ice:

1. Check the water supply to the ice machine. The machine is designed to shut off if there is no water to it. Check the filters if there are any.
2. Check the power supply to the machine. Reset the breaker if it is tripped.
3. If both water and power have been checked and are available, try switching the power Off and then On. After 2 minutes the machine should restart.

If this procedure restarts the machine, service should be called the next time the machine stops.