

NME1850R & FME2400R SERVICE PARTS

This parts list contains the service parts and wiring diagrams for this model. Check the model number in question to be sure that it is applicable to this parts list.

TABLE OF CONTENTS

Cabinet	2
Refrigeration	3
Water	4
Gearmotor.....	5
NME Evaporator	6
FME Evaporator	7
Control Box.....	8
Remote Condenser	9
Wiring Diagrams	10

NME1850R & FME2400R SERVICE PARTS

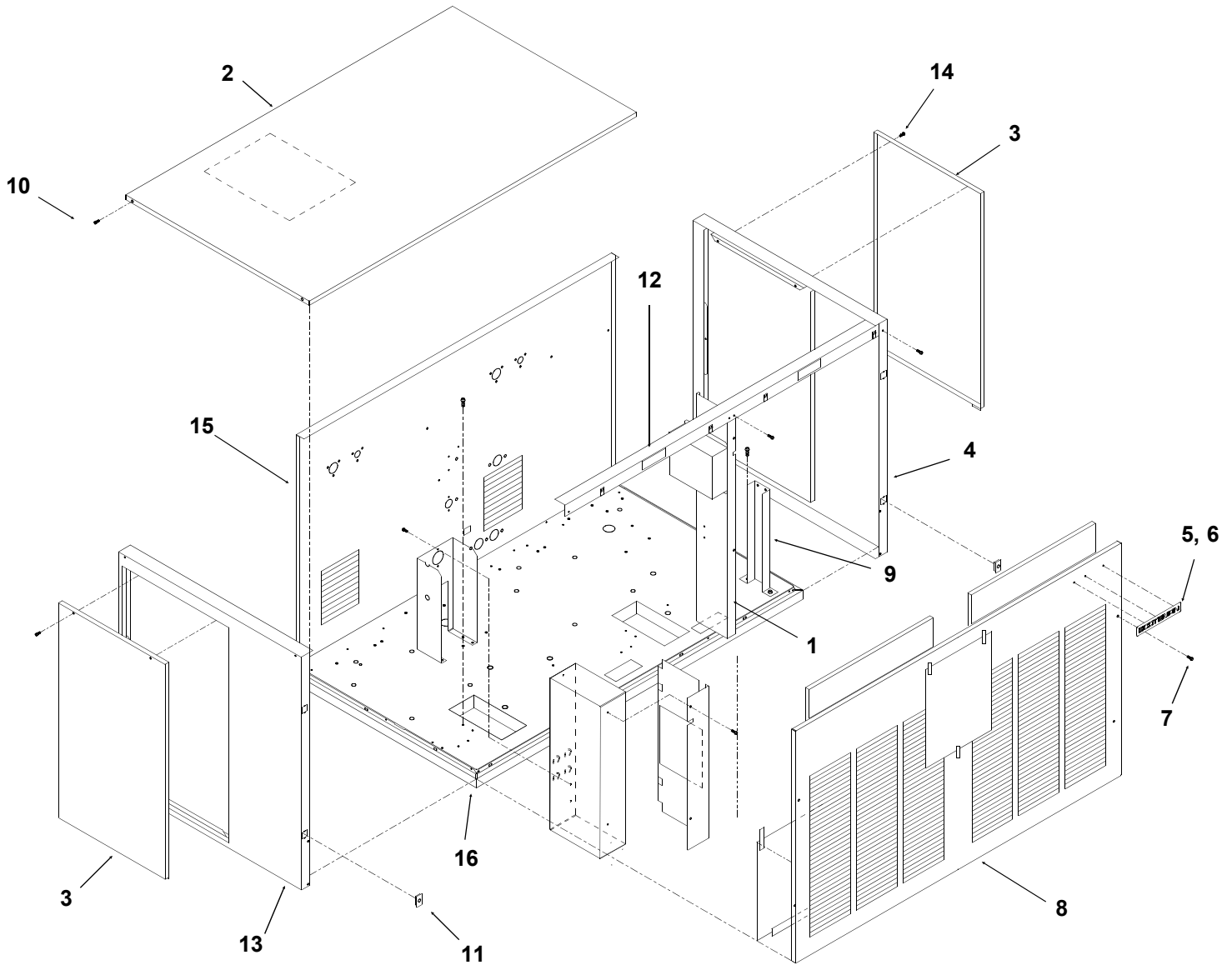

ITEM NUMBER	PART NUMBER	DESCRIPTION	ITEM NUMBER	PART NUMBER	DESCRIPTION
1	A34286-001	Center Support	8	A34294-001	Front Panel, sandalwood
2	A32461-001	Top Panel, sandalwood		A34294-015	Front panel, gray
	A32461-015	Top panel, gray		A34294-002	Front Panel, S.S.
	A32461-002	Top Panel, S.S.	9	A36078-001	Reservoir bracket
3	A34038-001	Service Panel, sandalwood	10	03-1531-01	Screw
	A34038-015	Service panel, gray	11	02-0836-00	Catch
	A34038-002	Service Panel, S.S.	12	A34287-001	Support
4	A33292-001	Right Side Panel, sandalwood	13	A32435-001	Left Side Panel, sandalwood
	A33292-015	Right side panel, painted		A32435-015	Left side panel, gray
	A33292-002	Right Side Panel, S.S.		A32435-002	Left Side Panel, S.S.
5	03-0271-00	Speed Clip	14	03-1404-12	Screw
6	15-0711-01	Emblem, sandalwood	15	A36517-001	Rear Panel Painted Only
	15-0808-03	Emblem, gray	16	A36554-001	Base
7	03-1419-22	Screw			

NME1850R & FME2400R SERVICE PARTS

Refrigeration System

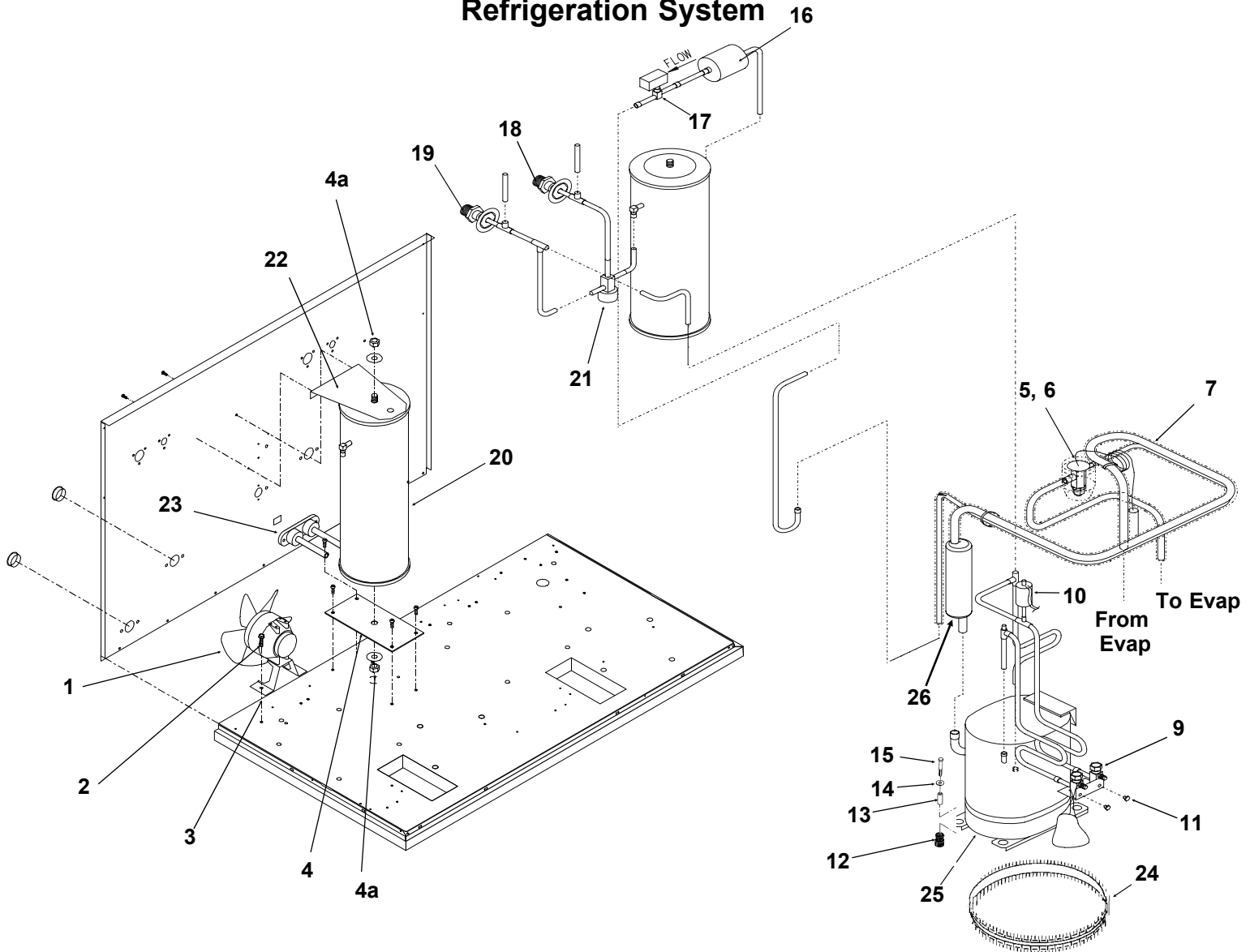

ITEM NUMBER	PART NUMBER	DESCRIPTION	ITEM NUMBER	PART NUMBER	DESCRIPTION
1	18-8708-01	Fan Blade	15	03-1405-20	Cap Screw
2	12-1576-02	Fan Motor	16	02-3319-02	Dryer
3	A35246-001	Fan Bracket	17	12-2135-02	Liquid line valve
4	A31801-002	Bracket	18	16-0850-01	Liquid line fitting
4a	03-1406-13	Nut	19	16-0850-03	Discharge line fitting
5	A32961-020	Insulation Kit (3 piece)	20	16-0761-01	Receiver
6	11-0488-21	Thermo Expansion Valve	21	11-0422-25	Discharge pressure control
7	A36496-001	Suction Line	22	A32968-001	Receiver bracket
8	A34285-001	Filler panel	23	02-3692-22	Drain fitting
9	16-0832-20	Access valve	24	12-1868-03	Crankcase heater
9a	16-0832-02	Stem cap	25	18-8768-22	Compressor 208-230/60/1
9b	16-0832-03	Core cap			Overload is internal
10	11-0485-21	Hi Pressure Cut Out		18-8768-24	Compressor 200-230/60/3
11	03-1645-01	Screw			Overload is internal
12	18-2200-28	Grommet			
13	18-2200-27	Sleeve			
14	03-1407-07	Washer			
			26.	16-0778-21	Accumulator

Note: Replacement compressors include a new HFC dryer & single phase include starting components

NME1850R & FME2400R SERVICE PARTS

Water System, Water Seal

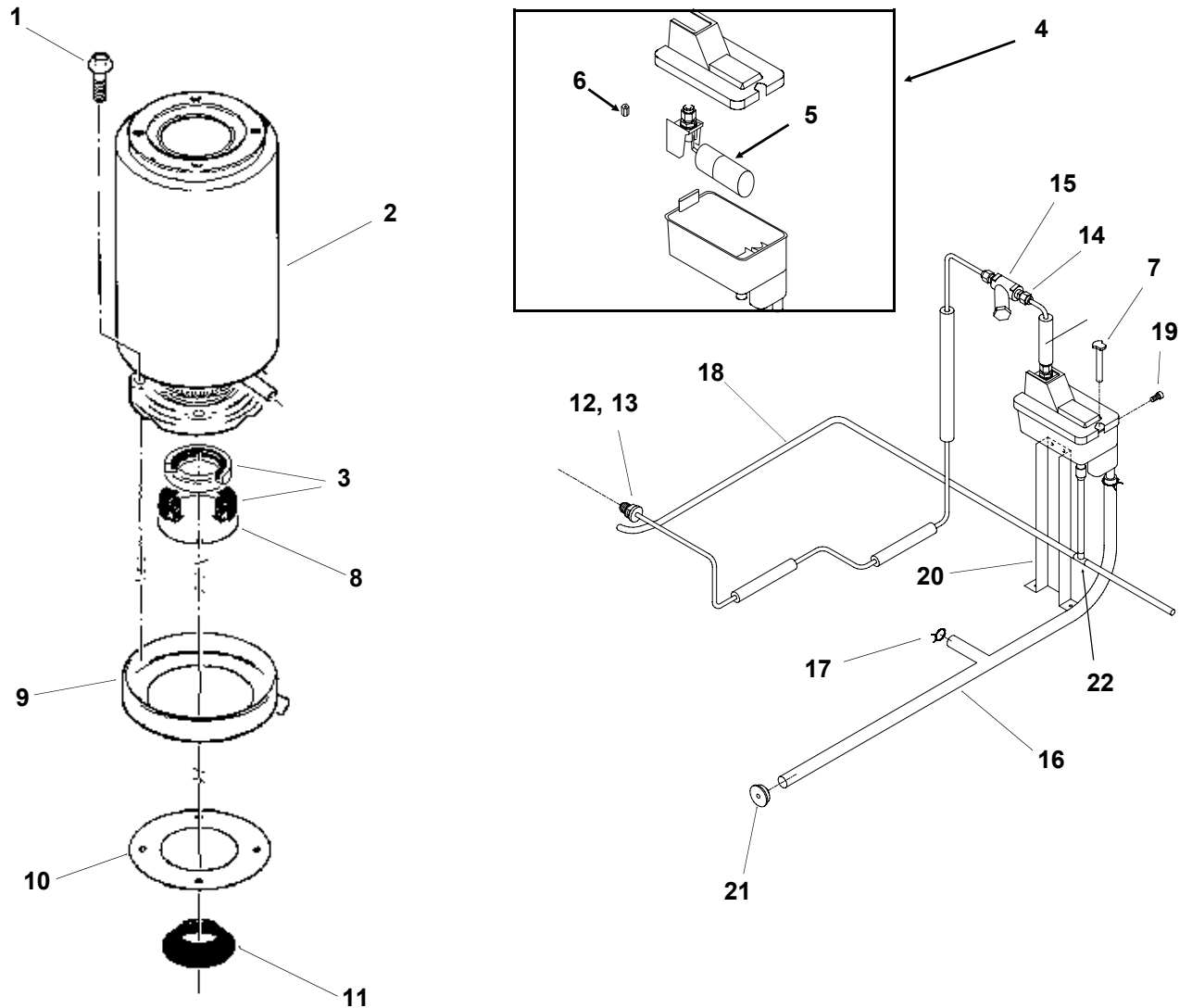

ITEM NUMBER	PART NUMBER	DESCRIPTION	ITEM NUMBER	PART NUMBER	DESCRIPTION
1	03-1420-03	Cap Screw	15	16-0162-00	Strainer - not used after 11/97
2	A32890-020	Evaporator	16	A36154-001	Evap. water inlet tube
3	02-0929-23	Water Seal	17	02-1338-00	Hose clamp
4	02-3266-20	Reservoir & valve	18	13-0079-03	Res. overflow hose
5	02-3266-21	Float valve	19	03-1639-03	Screw
6	02-3266-03	Plunger/seat	20	A36078-002	Reservoir bracket
7	A33101-022	Water Level Sensor	21	13-0840-01	Rubber cap
8	A32777-001	Retaining Ring for Seal	22	16-0670-02	Tee
9	02-3837-01	Drip Pan			
10	13-0704-00	Gasket			
11	13-0868-01	Water Shed			
12	A27318-001	Water Inlet Fitting for copper			
	16-0835-01	Inlet fitting for plastic tubing			
	16-1039-01	Male connector for plastic			
13	03-1394-01	Pal Nut			
14	16-0791-01	Coupling union			

NME1850R & FME2400R SERVICE PARTS

Gearmotor

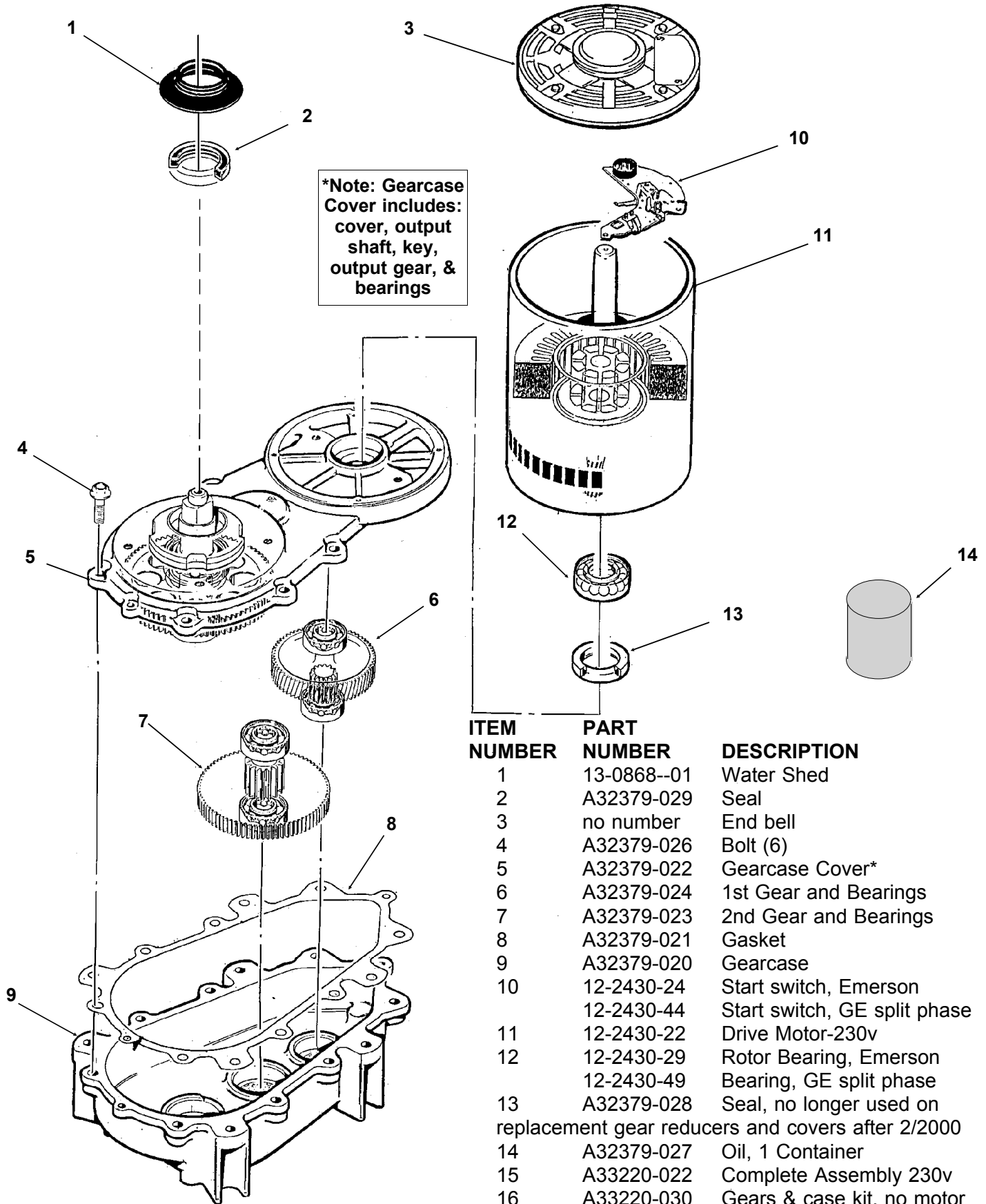

NME1850R & FME2400R SERVICE PARTS

NME Evaporator, Bin Controls

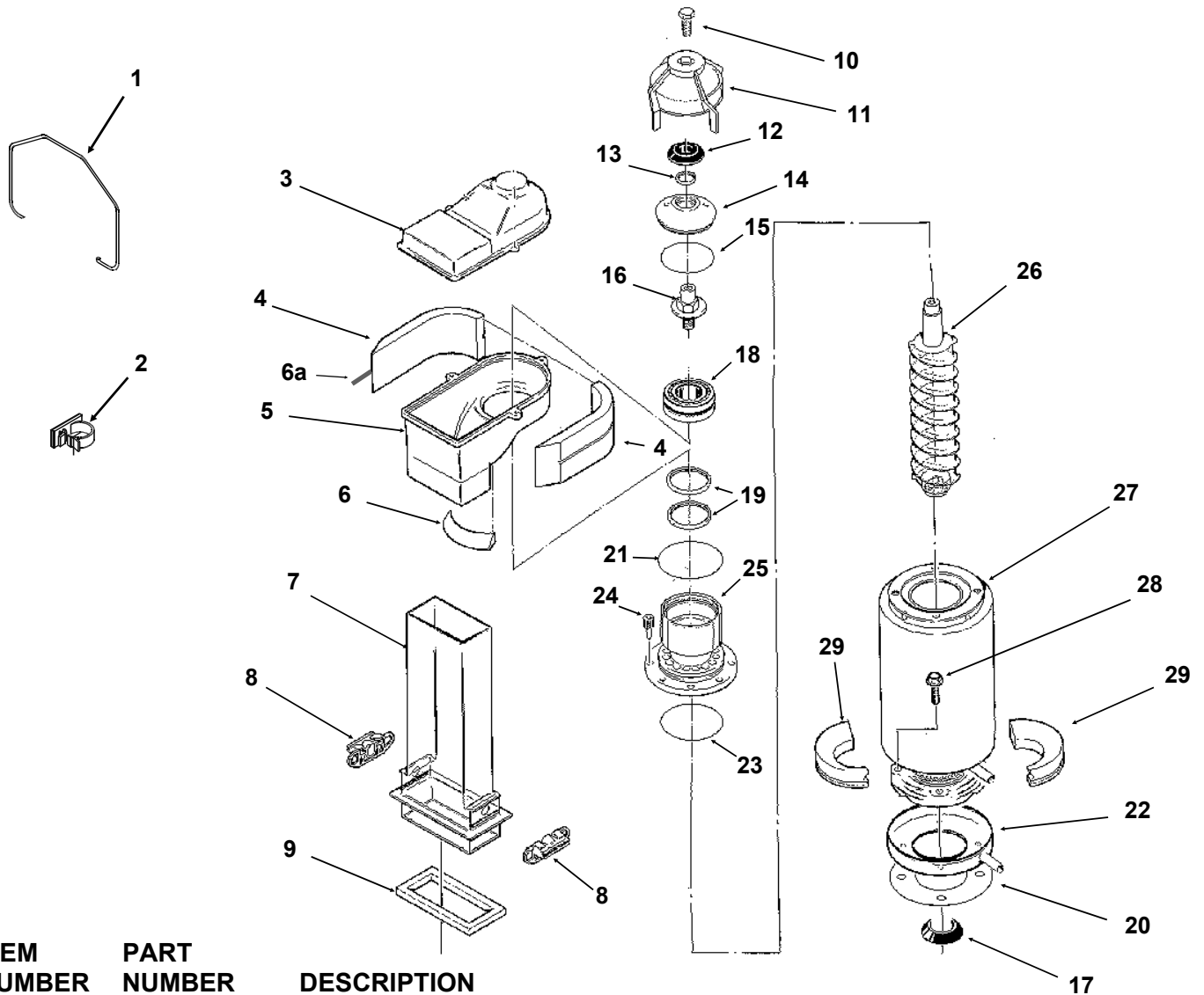

ITEM NUMBER	PART NUMBER	DESCRIPTION
1.	A34969-001	Bail clip
2.	02-3268-01	Drain tube holder
3.	02-2930-04	Ice Chute Cover
4.	A32963-001	Insulation Top (half)
5.	02-2926-01	Ice Chute Body
6.	A33102-001	Insulation Collar Inside
6a.	A35419-020	Strap kit
7.	02-2929-04	Ice Chute Lower
8.	A37708-021	Bin Controls Assy. (set of 2)
9.	A32930-001	Chute Gasket
10.	03-1405-52	Hex Cap Screw
11.	02-3001-01	Ice Sweep
12.	13-0871-01	Water Shed
13.	02-2978-01	Lip Seal
14.	02-3128-20	Breaker Cover
15.	13-0617-52	O-Ring
16.	08-0660-01	Auger Stud & washer
17.	13-0868-01	Water Shed
18.	A34559-020	Bearing
19.	02-2977-01	Lip Seal
20.	13-0704-00	Drip Pan Gasket
21.	13-0617-54	O-Ring
22.	02-3837-01	Drip Pan
23.	13-0617-45	O-Ring
24.	03-1544-08	Soc. Head Screw
25.	A32900-020	Breaker (includes 18 & 19)
26.	A38071-022	Auger
27.	A32890-020	Evaporator
28.	03-1405-41	Cap Screw
29.	A32962-001	Insulation Bot. (half)

NME1850R & FME2400R SERVICE PARTS

FME Evaporator, Bin Controls

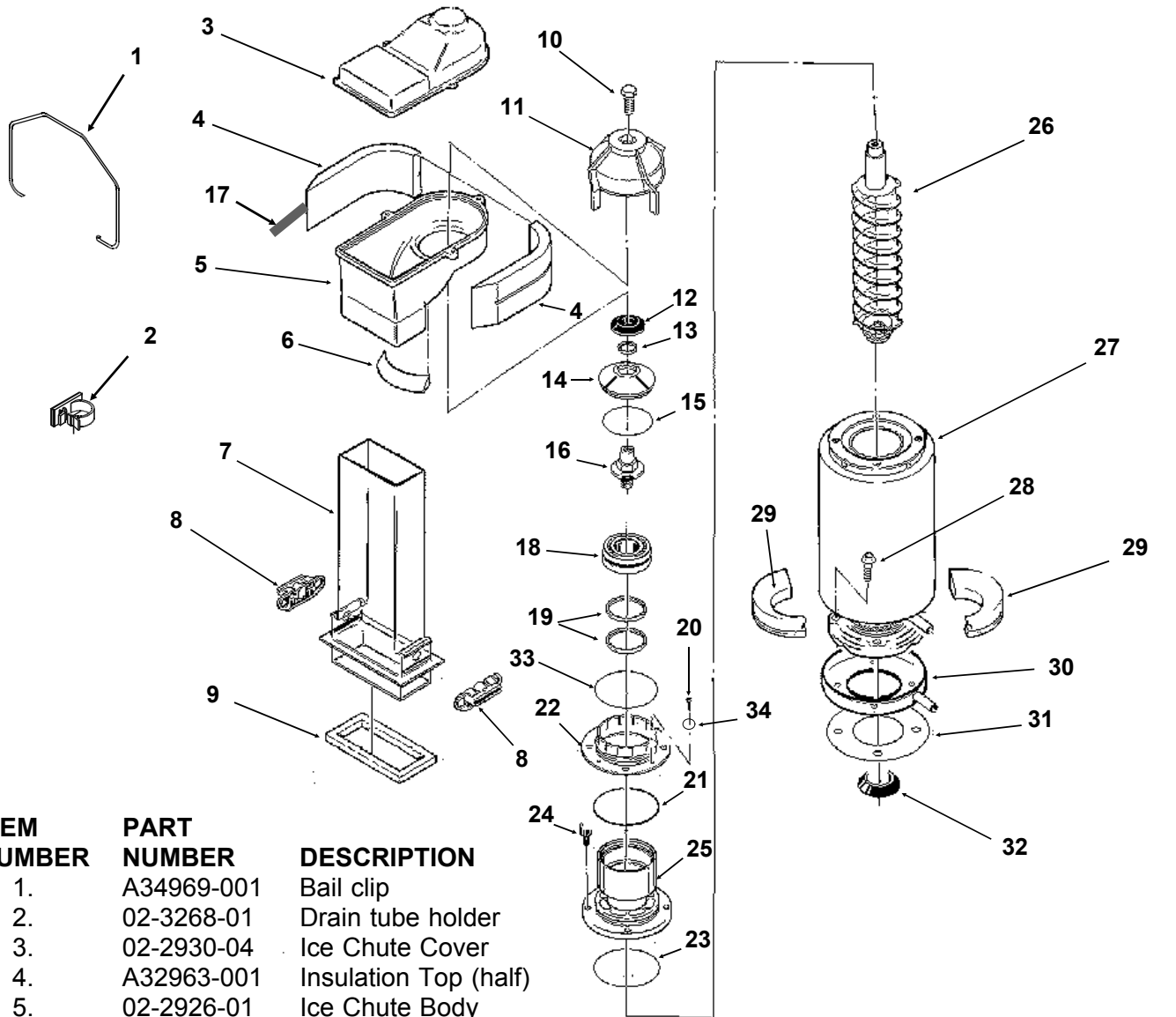

ITEM NUMBER	PART NUMBER	DESCRIPTION
1.	A34969-001	Bail clip
2.	02-3268-01	Drain tube holder
3.	02-2930-04	Ice Chute Cover
4.	A32963-001	Insulation Top (half)
5.	02-2926-01	Ice Chute Body
6.	A33102-001	Insulation Collar Inside
7.	02-2929-04	Ice Chute Lower
8.	A37708-021	Bin Controls Assy. (set of 2)
9.	A32930-001	Chute Gasket
10.	03-1405-52	Hex Cap Screw
11.	02-3001-01	Ice Sweep
12.	13-0871-01	Water Shed
13.	02-2978-01	Lip Seal
14.	02-3128-20	Breaker Cover
15.	13-0617-54	O-Ring
16.	08-0660-01	Auger Stud, thrust Washer
17.	A35419-020	Strap kit
18.	A34559-020	Bearing
19.	02-2977-01	Lip Seal
20.	03-1405-27	Screw
21.	13-0617-52	O-Ring
22.	02-2916-01	Slotted Collar
23.	13-0617-45	O-Ring
24.	03-1544-08	Soc. Head Screw
25.	A34505-020	Breaker (Divider) (includes 18 & 19)
26.	A38071-022	Auger
27.	A32890-020	Evaporator
28.	03-1405-41	Cap Screw
29.	A32962-001	Insulation Bot. (half)
30.	02-3837-01	Drip Pan
31.	13-0704-00	Drip Pan Gasket
32.	13-0868-01	Water Shed
33.	13-0617-49	O-Ring
34.	03-1408-36	Washer

NME1850R & FME2400R SERVICE PARTS

Control Box

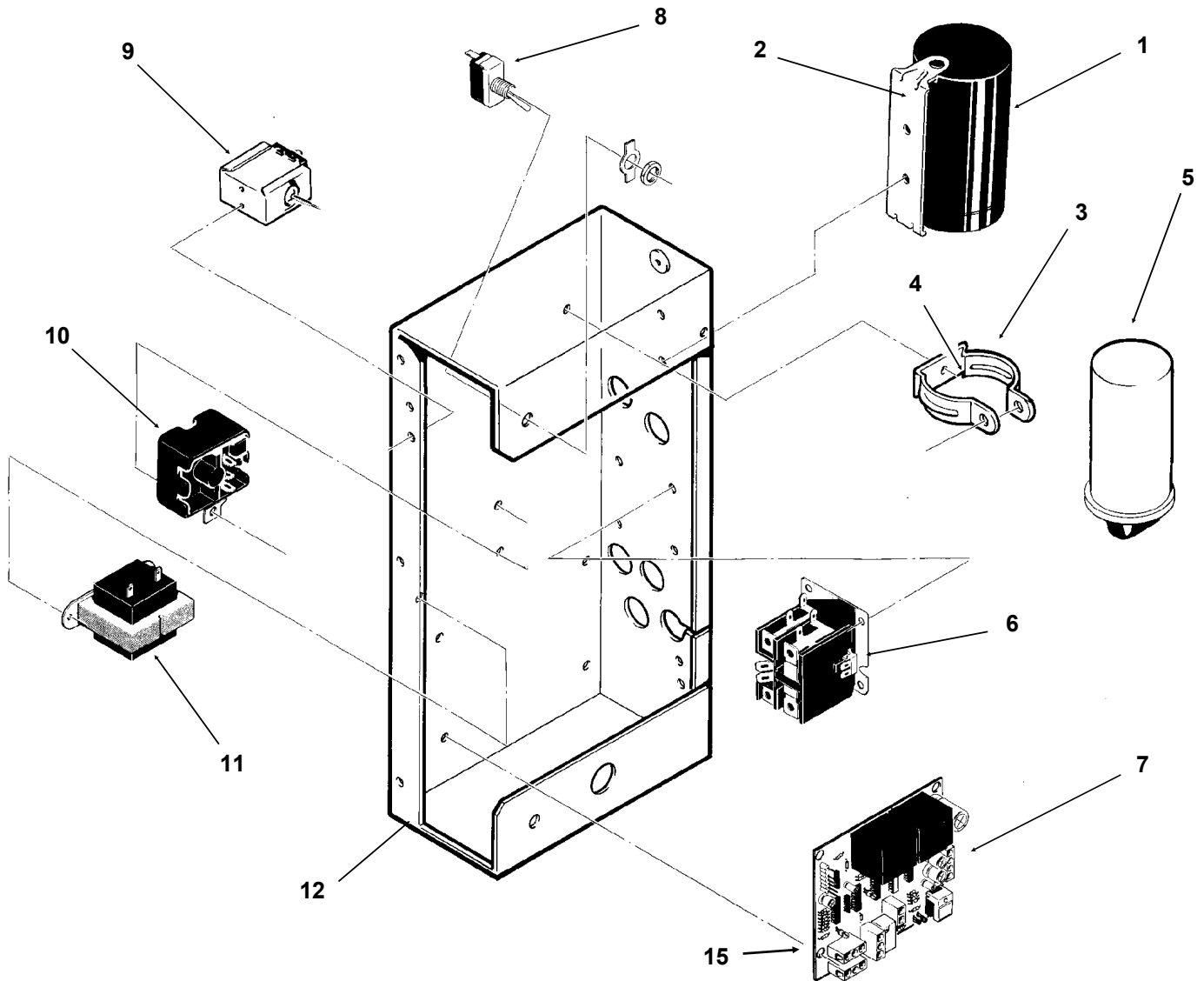

ITEM NUMBER	PART NUMBER	DESCRIPTION	ITEM NUMBER	PART NUMBER	DESCRIPTION
1	18-1901-54	Start Capacitor	7	A37750-021	Circuit Board
	18-2200-38	Start Capacitor Cap.	8.	12-0426-01	Master Switch
2.	18-2200-39	Start Capacitor Bracket	9.	11-0420-24	Pump down control
	03-1638-04	Screw	10	18-1903-33	Potential Relay
	03-1417-15	Lockwasher	11.	12-2285-22	Transformer
3.	A32872-001	Run Cap Bracket	12	no number	Control Box Assy
	03-1652-02	Bolt	NOT ILLUSTRATED		
	03-0255-04	Wing Nut	13.	12-2340-01	4 Pin Plug Assy
4.	03-1638-03	Screw	(Transformer to Circuit Board)		
5.	18-1902-45	Run Capacitor	14	12-2350-01	Spacer/screw
6.	12-2469-02	Single Phase Contactor	Separate From The Control Box		
	12-0739-02	Three Phase Contactor	15.	12-2070-04	Fan Motor Relay
			(in a separate control box)		
			16.	A34055-001	Control box cover

NME1850R & FME2400R SERVICE PARTS

Remote Condenser

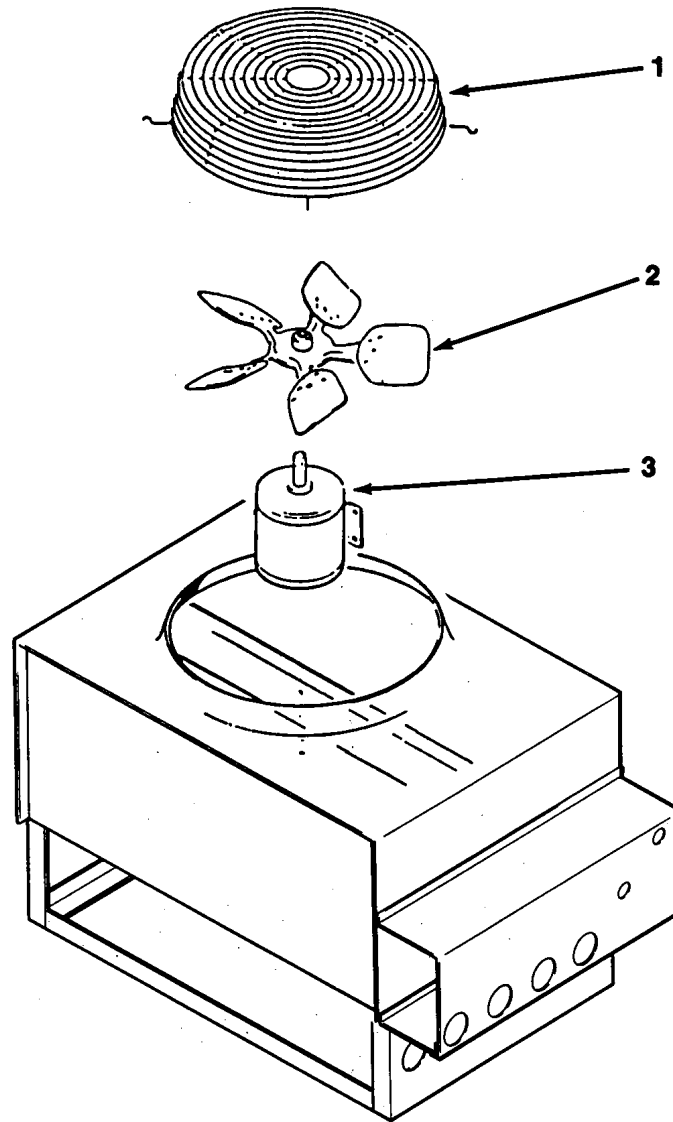

RCE502

ITEM NUMBER	PART NUMBER	DESCRIPTION
1.	02-2618-01	Fan Guard
2.	18-6304-01	Fan Blade
3.	18-5301-01	Fan Motor
4.	16-1057-01	Line connection, female half 3/8"
5.	16-1057-02	Line connection, female half 1/2"

ERC302

1	02-3575-01	Fan guard
2	18-8800-01	Fan blade
3	18-8796-32	Fan motor

NME1850R & FME2400R SERVICE PARTS

Component Layout Diagram 208-230/60/1

A36515-032

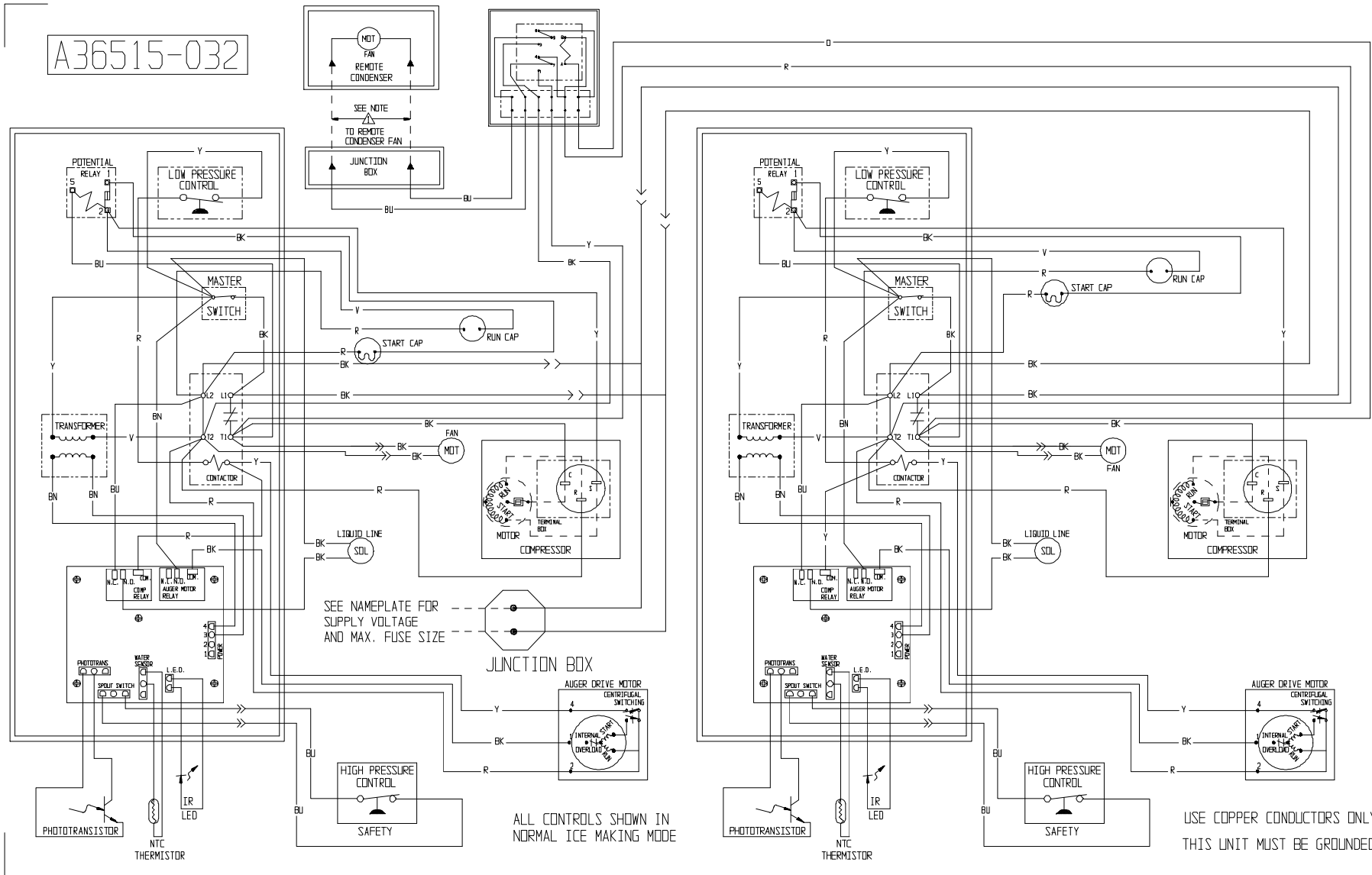

NME1850R & FME2400R SERVICE PARTS

Schematic Diagram 208-230/60/1

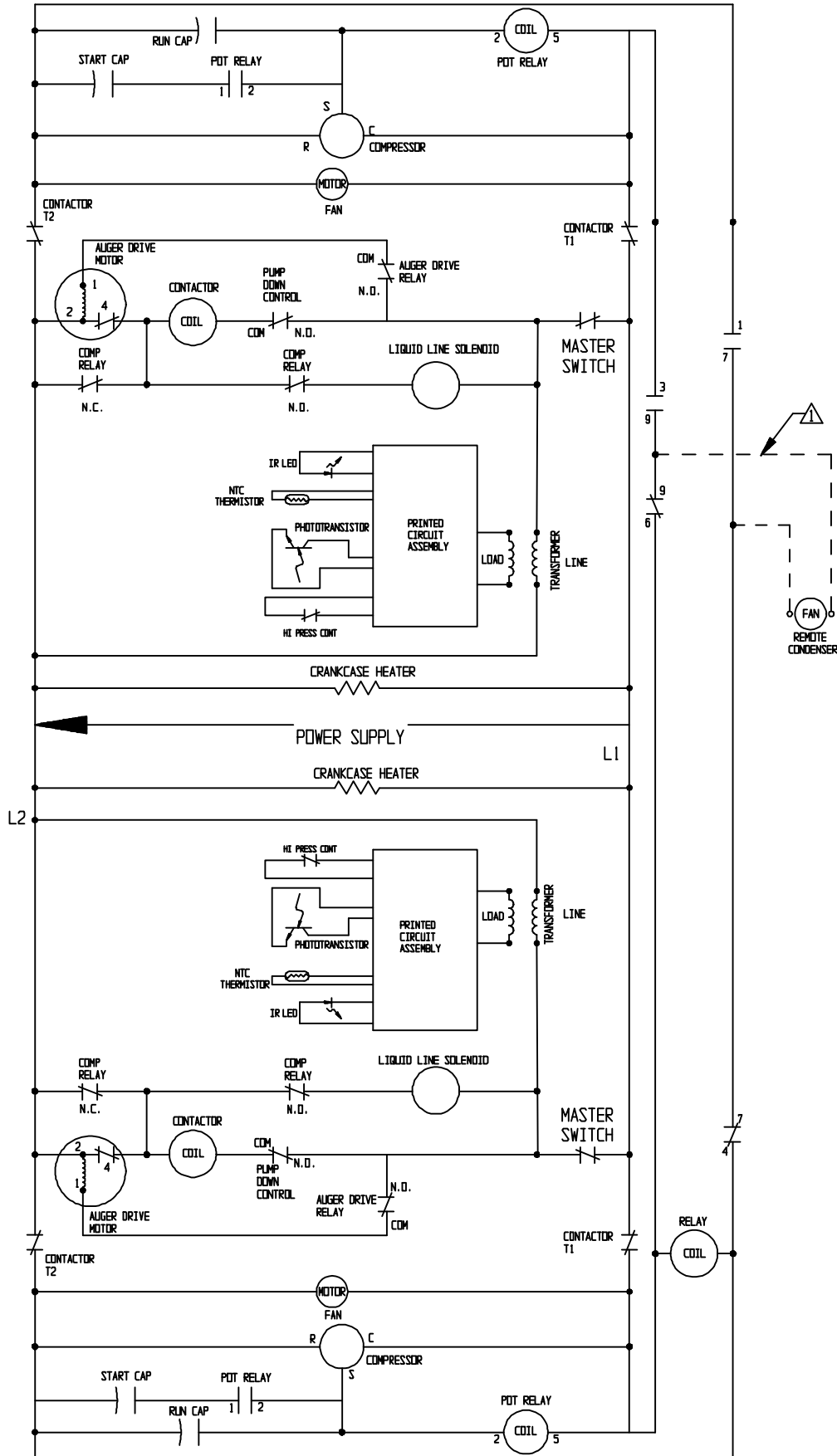

A36515-003

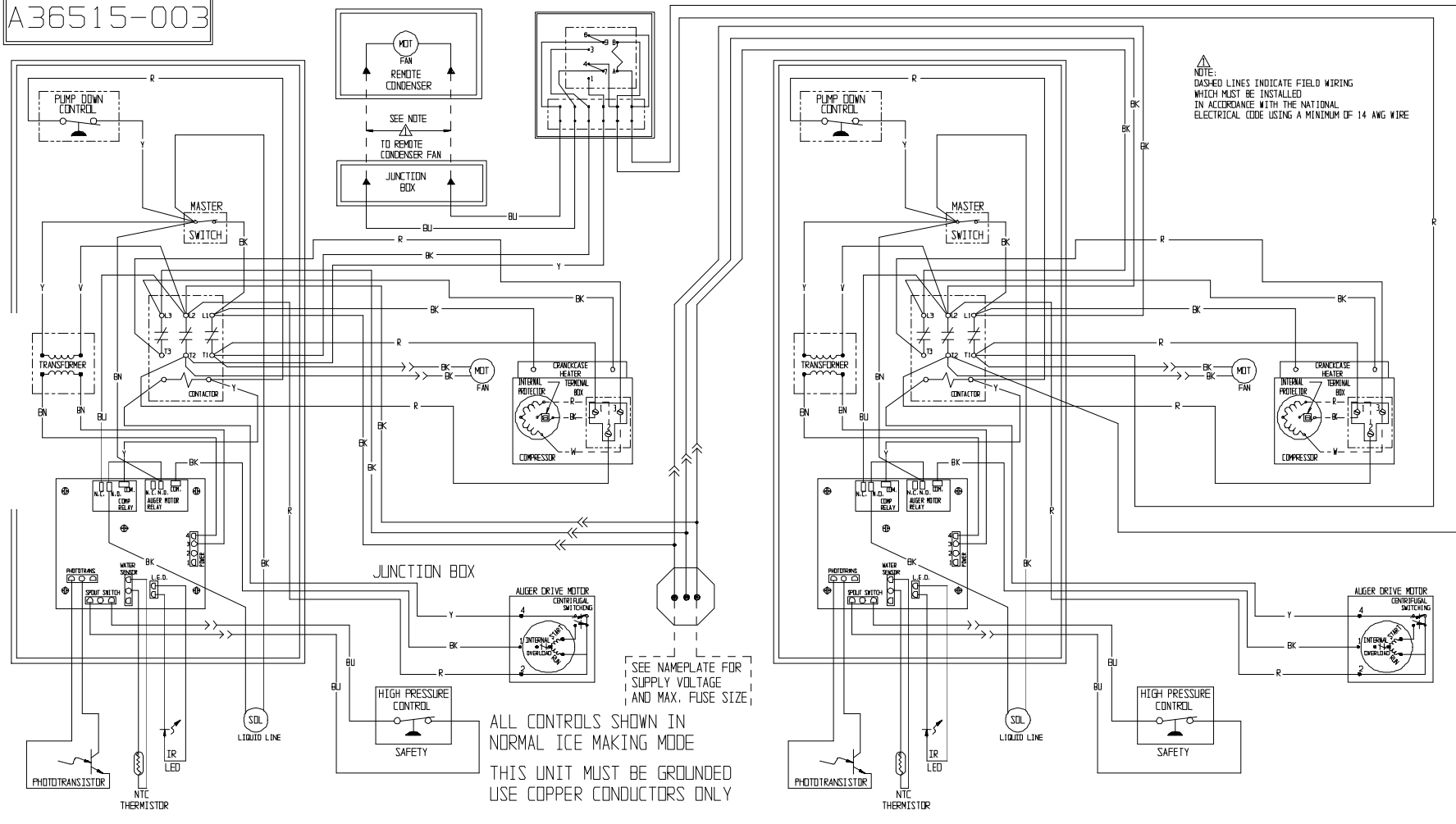

NME1850R & FME2400R SERVICE PARTS
 Component Layout Diagram 208-230/60/3

NME1850R & FME2400R SERVICE PARTS

Schematic Diagram 208-230/60/3

