

NME1850 & FME2400 SERVICE PARTS

This parts list contains the service parts and wiring diagrams for this model. Check the model number in question to be sure that it is applicable to this parts list.

TABLE OF CONTENTS

Cabinet	2
Air Cooled Refrigeration	3
Water Cooled Refrigeration.....	4
Water System.....	5
Gearmotor.....	6
NME Evaporator	7
FME Evaporator	8
Control Box.....	9
Wiring Diagrams.....	10

NME1850 & FME2400 SERVICE PARTS

Cabinet Assembly

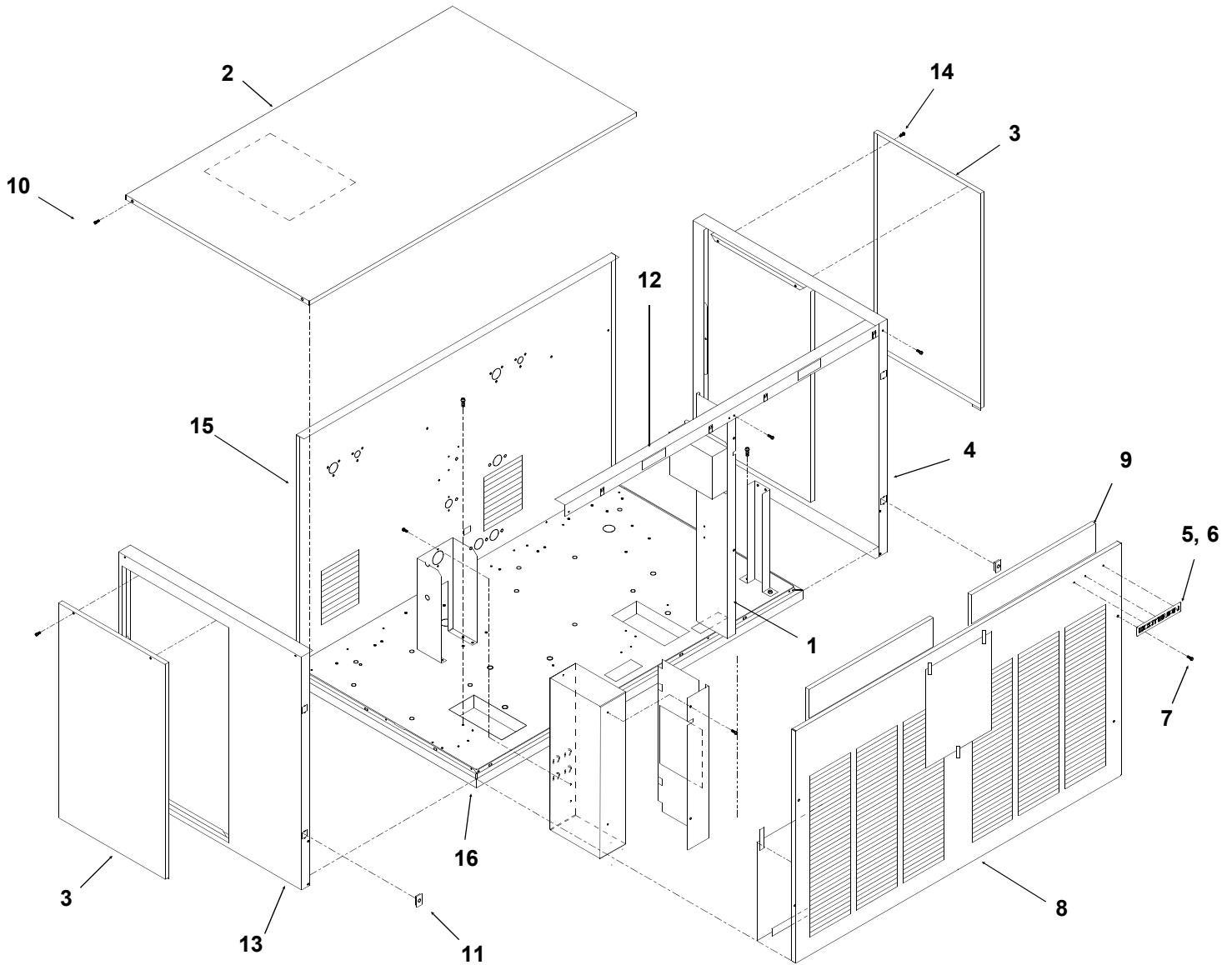

ITEM NUMBER	PART NUMBER	DESCRIPTION	ITEM NUMBER	PART NUMBER	DESCRIPTION
1	A34286-001	Center Support	8	A34294-001	Front Panel, sandalwood
2	A32461-001	Top Panel, sandalwood		A34294-015	Front panel, gray
	A32461-015	Top panel, gray		A34294-002	Front Panel, S.S.
3	A34038-001	Service Panel, sandalwood	9	02-2976-01	Air filter
	A34038-015	Service panel, gray		03-1660-01	Clip for filter
	A34038-002	Service Panel, S.S.	10	03-1531-01	Screw
4	A33292-001	Right Side Panel, sndlwd	11	02-0836-00	Catch
	A33292-015	Right side panel, gray	12	A34287-001	Support
	A33292-002	Right Side Panel, S.S.	13	A32435-001	Left Side Panel, Sndlwd
5	03-0271-00	Speed Clip		A32435-015	Left side panel, gray
6	15-0711-01	Emblem, sandalwood		A32435-002	Left Side Panel, S.S.
	15-0808-03	Emblem, gray	14	03-1404-12	Screw
7	03-1419-22	Screw	15	A36517-001	Rear Panel, sandalwood
				A36517-015	Rear panel, gray
				Item 15 for Water Cooled Painted Only	
			16.	A36554-001	Base

NME1850 & FME2400 SERVICE PARTS

Air Cooled Refrigeration

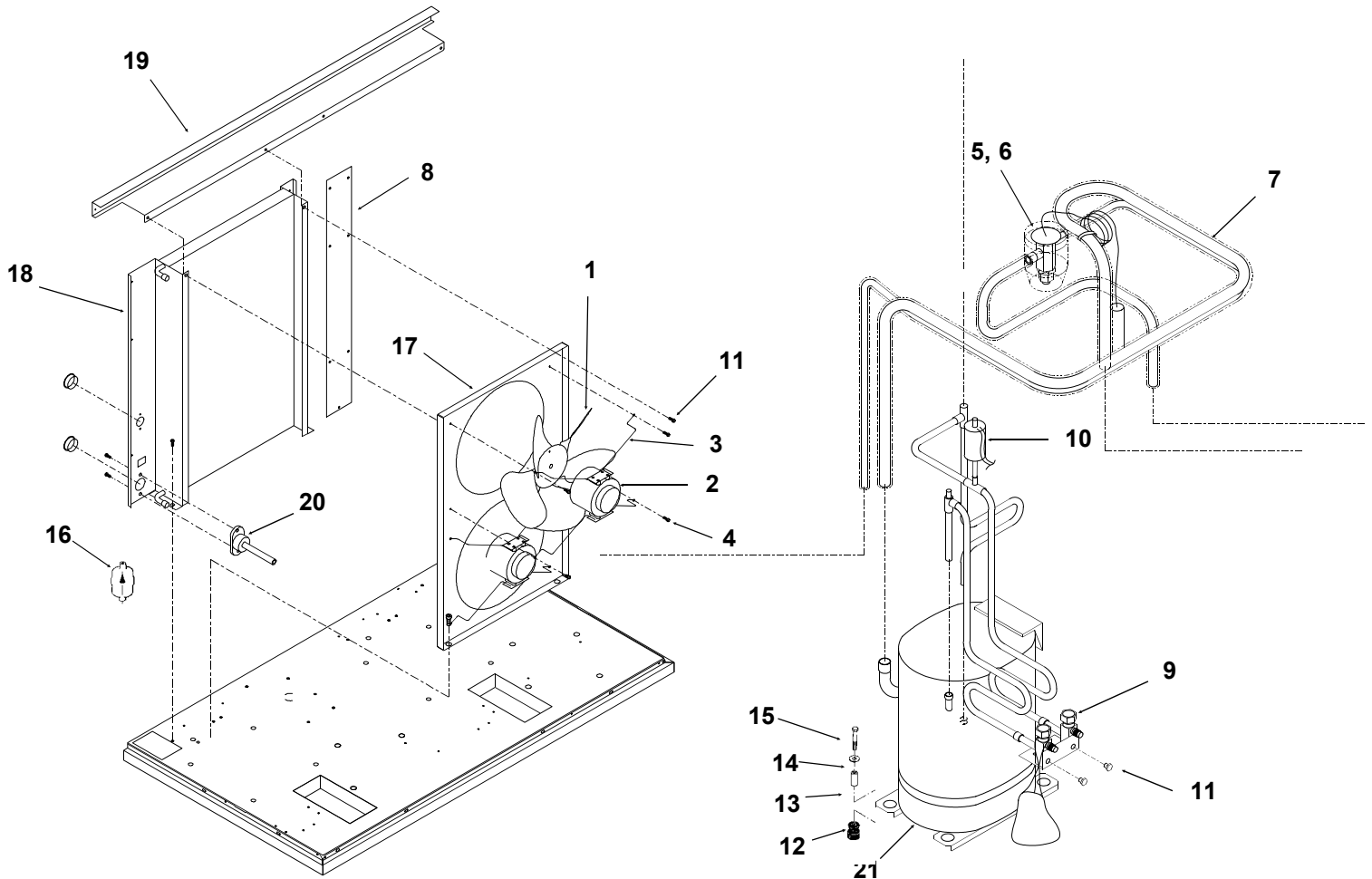

ITEM NUMBER	PART NUMBER	DESCRIPTION	ITEM NUMBER	PART NUMBER	DESCRIPTION
1	18-3815-01	Fan Blade	14	03-1407-07	Washer
2	12-1576-02	Fan Motor	15	03-1405-20	Cap Screw
3	02-2378-01	Fan Bracket	16	02-3319-02	Dryer
4	03-1531-01	Screw	17	A33231-001	Fan Shroud
5	A32961-020	Insulation Kit (3 piece)	18	18-8717-01	Condenser
6	11-0488-21	Thermo Expansion Valve	19	A35613-001	Condenser Support
7	A36496-001	Suction Line	20	A32282-004	Drain fitting
8	A34285-001	Filler panel	21	18-8768-22	Compressor 208-230/60/1 Overload is internal
9	16-0832-20	Access valve		18-8768-24	Compressor 200-230/60/3 Overload is internal
9a	16-0832-02	Stem cap		18-8772-26	Compressor 230/50/1
9b	16-0832-03	Core cap		18-8772-21	Overload
10	11-0485-21	Hi Pressure Cut Out			
11	03-1645-01	Screw			
12	18-2200-28	Grommet			
13	18-2200-27	Sleeve			

Note: Replacement compressors include a new HFC dryer, and single phase 60 Hz replacments include the starting components.

NME1850 & FME2400 SERVICE PARTS

Water Cooled Refrigeration

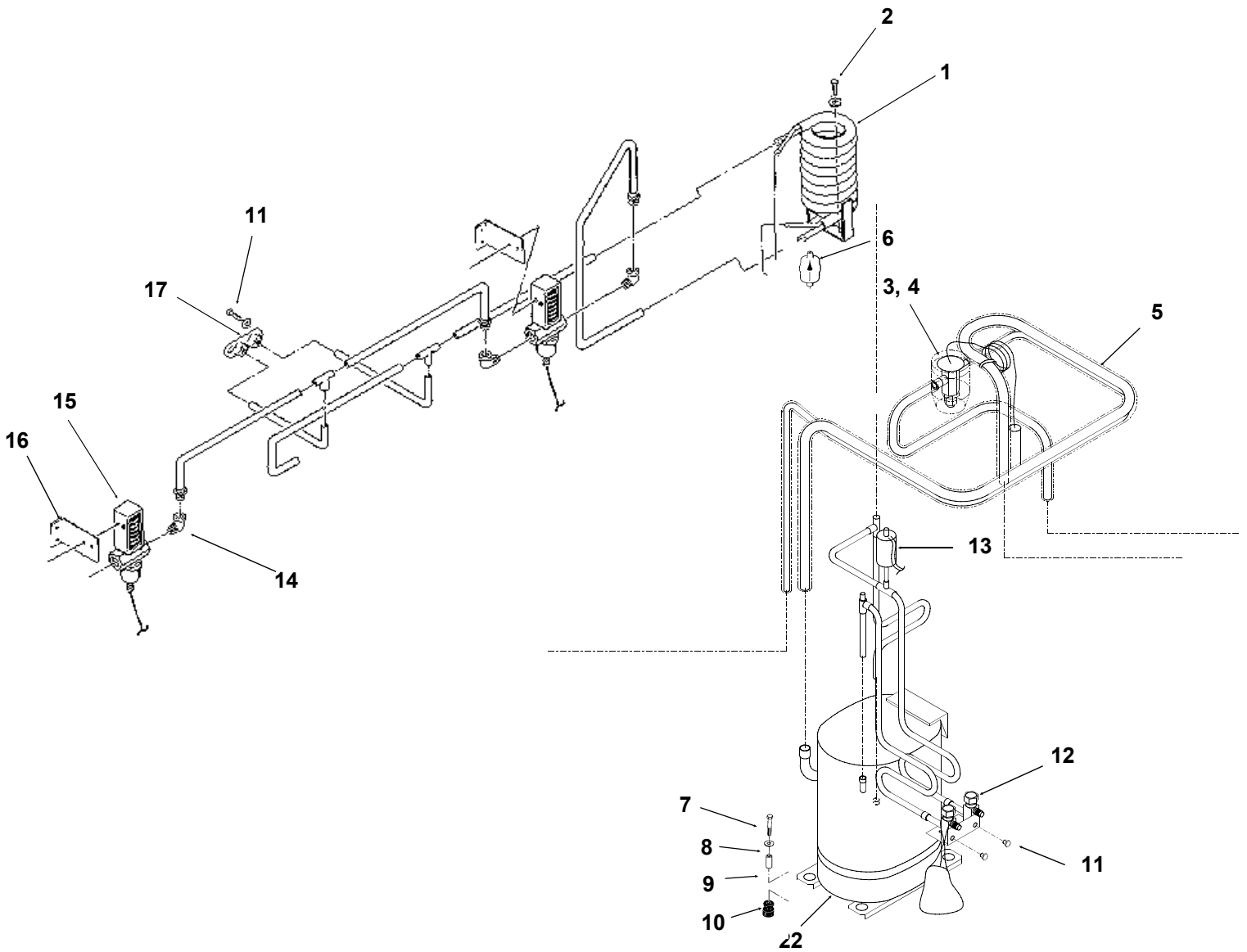

ITEM NUMBER	PART NUMBER	DESCRIPTION
1	18-8718-25	Condenser
2	03-1645-01	Screw
3	11-0488-21	Thermo Expansion Valve
4	A32961-020	Insulation Kit (3 piece)
5	A36496-001	Suction Line
6	02-3319-02	Dryer
7	03-1405-20	Cap Screw
8	03-1407-07	Washer
9	18-2300-27	Sleeve
10	18-2200-28	Grommet
11	03-1645-01	Screw
12	16-0832-20	Access valve
12a	16-0832-02	Stem cap
12b	16-0832-03	Core cap
13	11-0485-21	Hi Pressure Cut Out
14	16-0401-02	Elbow
15	11-0478-01	Water Reg. Valve
16	A34341-001	Bracket
17	A31878-004	Drain Assembly
18	18-8768-22	Compressor 208-230/60/1 Overload is internal
	18-8768-24	Compressor 200-230/60/3 Overload is internal
	18-8772-26	Compressor 230/50/1
	18-8772-21	Overload

Note: Replacement compressors include a new HFC dryer, and single phase 60 Hz replacements include the starting components.

NME1850 & FME2400 SERVICE PARTS

Water System

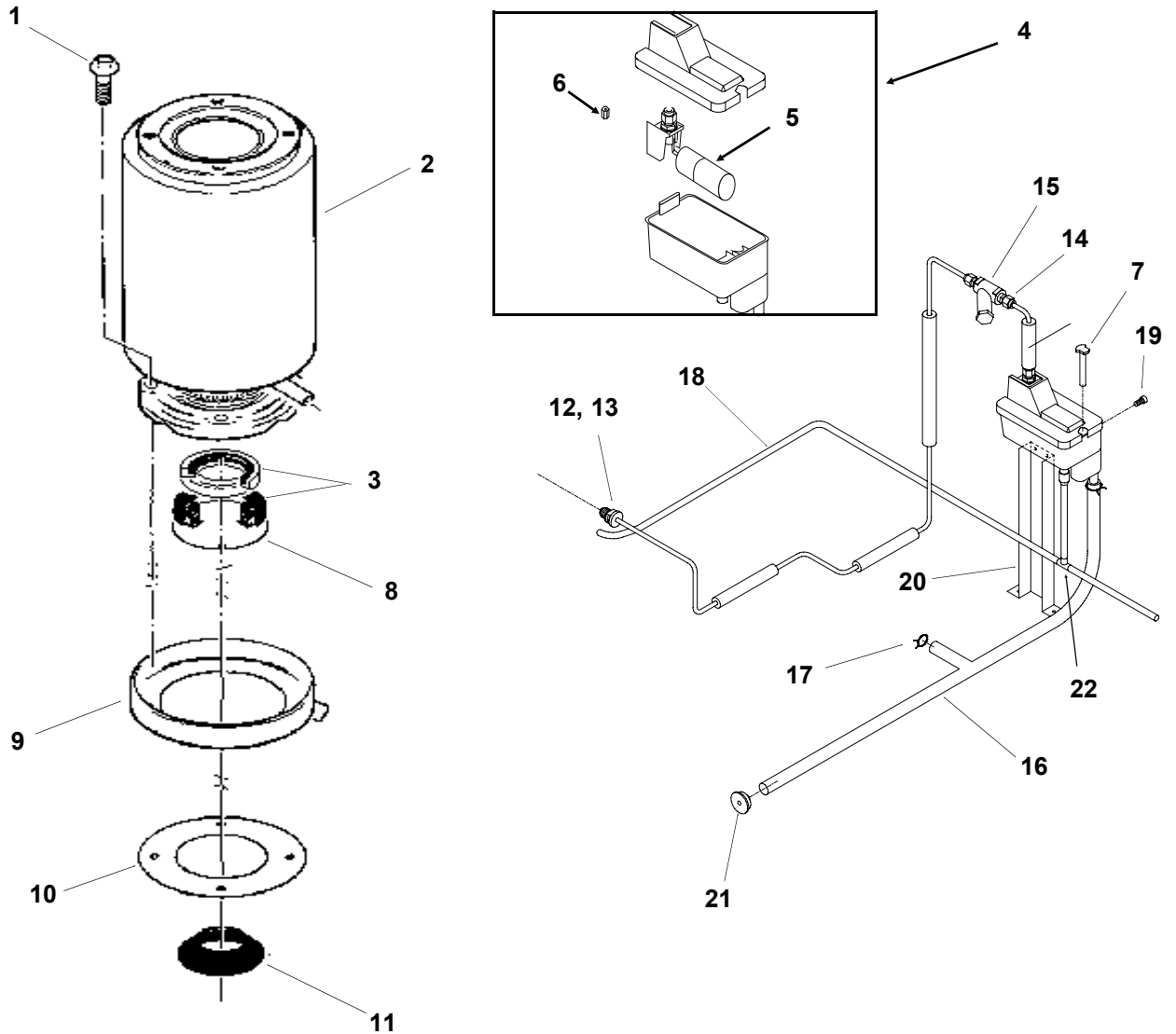

ITEM NUMBER	PART NUMBER	DESCRIPTION	ITEM NUMBER	PART NUMBER	DESCRIPTION
1	03-1420-03	Cap Screw	15	16-0162-00	Strainer - not used after 11/97
2	A32890-020	Evaporator	16	A36154-001	Evap. water inlet tube
3	02-0929-23	Water Seal	17	02-1338-00	Hose clamp
4	02-3266-20	Reservoir & valve	18	13-0079-03	Res. overflow hose
5	02-3266-21	Float valve	19	03-1639-03	Screw
6	02-3266-03	Plunger/seat	20	A36078-002	Reservoir bracket
7	A33101-022	Water Level Sensor	21	13-0840-01	Rubber cap
8	A32777-001	Retaining Ring for Seal	22	16-0670-02	Tee
9	02-3837-01	Drip Pan			
10	13-0704-00	Gasket			
11	13-0868-01	Water Shed			
12	A27318-001	Water Inlet Fitting - for copper			
	16-0835-01	Inlet fitting for plastic tubing			
	16-1039-01	Male connector			
13	03-1394-01	Pal Nut			
14	16-0791-01	Coupling union			

NME1850 & FME2400 SERVICE PARTS

Gearmotor

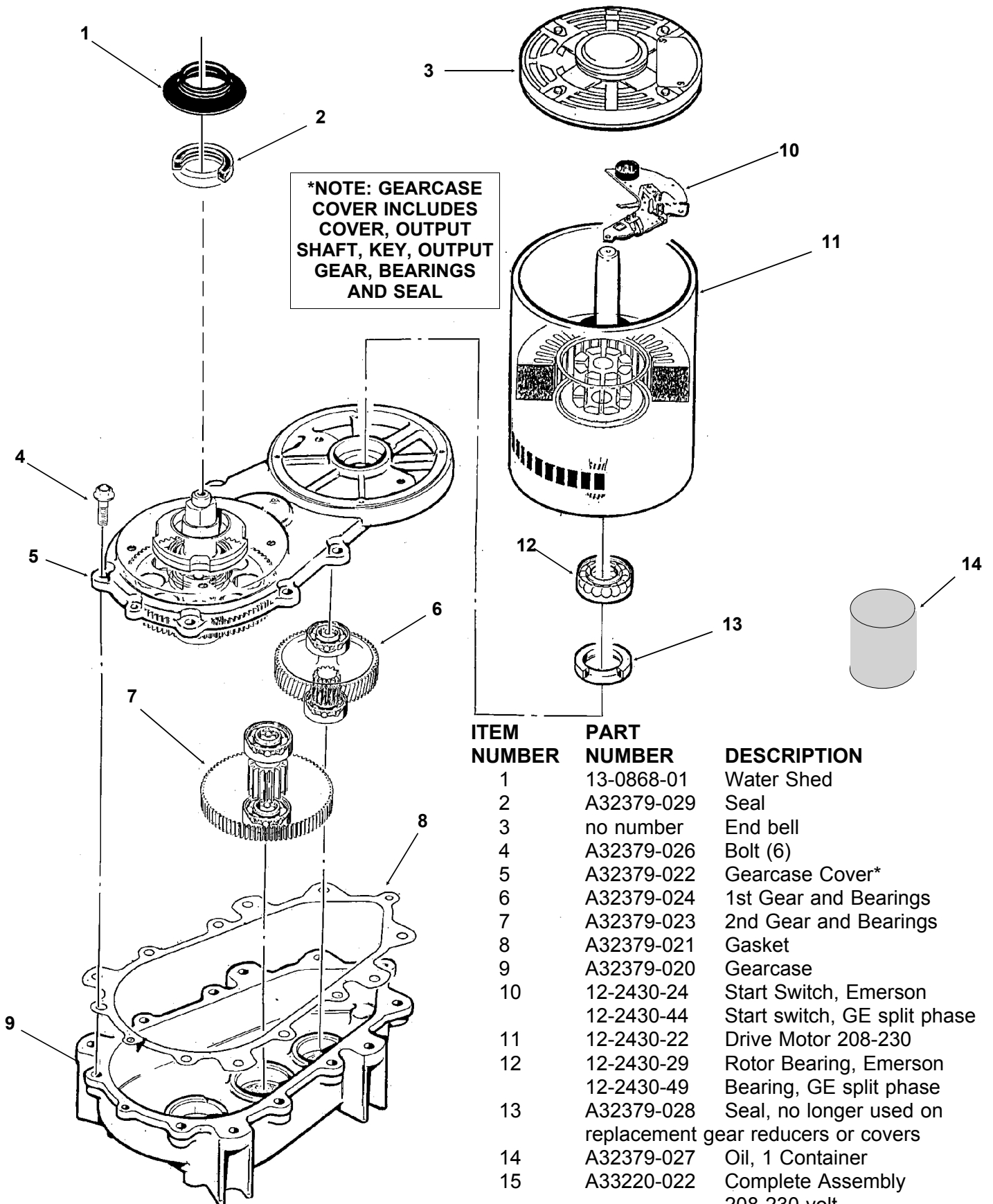

***NOTE: GEARCASE COVER INCLUDES COVER, OUTPUT SHAFT, KEY, OUTPUT GEAR, BEARINGS AND SEAL**

ITEM NUMBER	PART NUMBER	DESCRIPTION
1	13-0868-01	Water Shed
2	A32379-029	Seal
3	no number	End bell
4	A32379-026	Bolt (6)
5	A32379-022	Gearcase Cover*
6	A32379-024	1st Gear and Bearings
7	A32379-023	2nd Gear and Bearings
8	A32379-021	Gasket
9	A32379-020	Gearcase
10	12-2430-24	Start Switch, Emerson
	12-2430-44	Start switch, GE split phase
11	12-2430-22	Drive Motor 208-230
12	12-2430-29	Rotor Bearing, Emerson
	12-2430-49	Bearing, GE split phase
13	A32379-028	Seal, no longer used on replacement gear reducers or covers
14	A32379-027	Oil, 1 Container
15	A33220-022	Complete Assembly 208-230 volt
16	A33220-030	Gearcase kit, no motor

NME1850 & FME2400 SERVICE PARTS

NME Evaporator

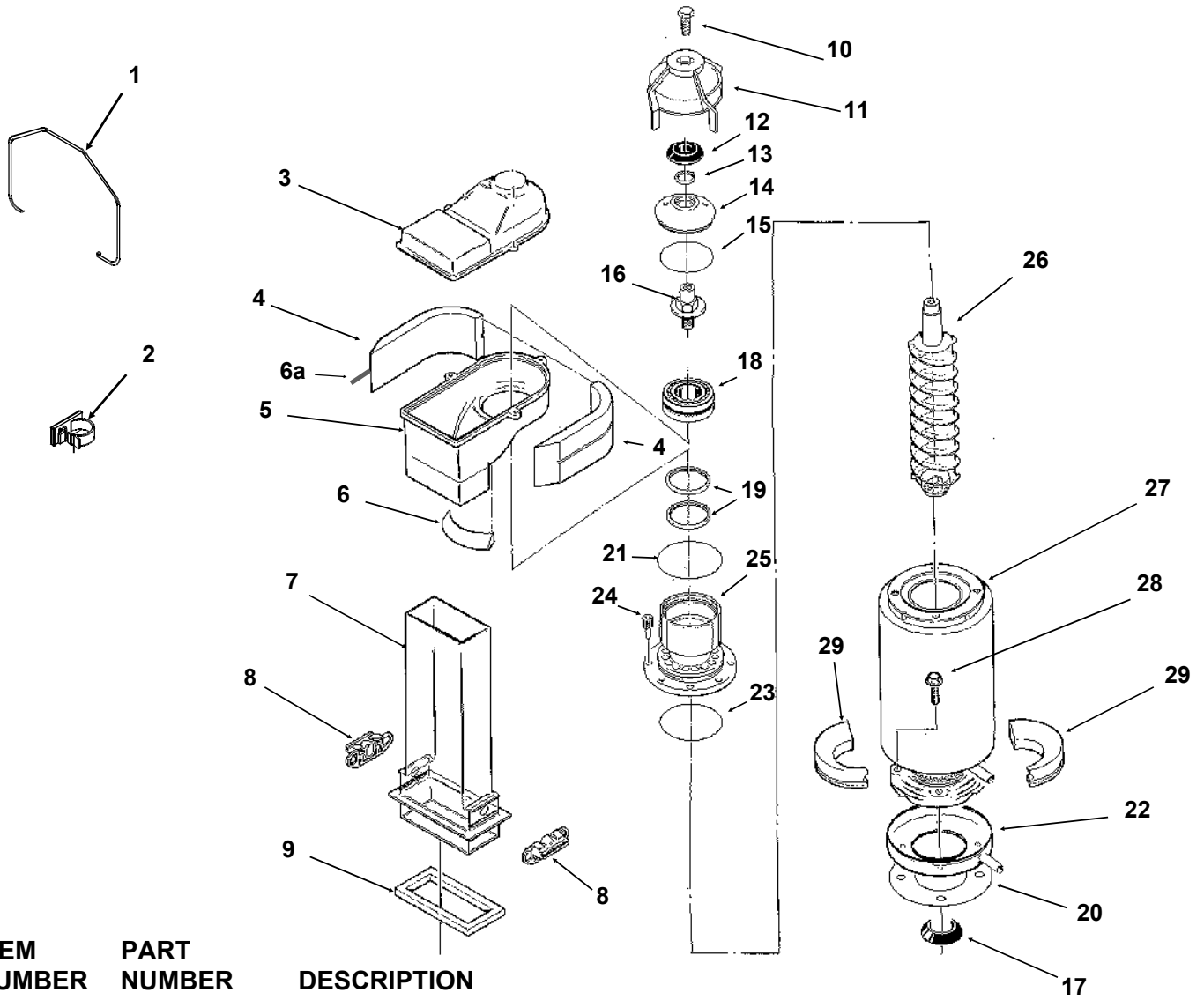

ITEM NUMBER	PART NUMBER	DESCRIPTION
1.	A34969-001	Bail clip
2.	02-3268-01	Drain tube holder
3.	02-2930-04	Ice Chute Cover
4.	A32963-001	Insulation Top (half)
5.	02-2926-01	Ice Chute Body
6.	A33102-001	Insulation Collar Inside
6a	A35419-020	Strap kit
7.	02-2929-04	Ice Chute Lower
8.	A37708-021	Bin Controls Assy. (set of 2)
9.	A32930-001	Chute Gasket
10.	03-1405-52	Hex Cap Screw
11.	02-3001-01	Ice Sweep
12.	13-0871-01	Water Shed
13.	02-2978-01	Lip Seal
14.	02-3128-20	Breaker Cover
15.	13-0617-52	O-Ring
16.	08-0660-01	Auger Stud & washer
17.	13-0868-01	Water Shed
18.	A34559-020	Bearing
19.	02-2977-01	Lip Seal
20.	13-0704-00	Drip Pan Gasket
21.	13-0617-54	O-Ring
22.	02-3837-01	Drip Pan
23.	13-0617-45	O-Ring
24.	03-1544-08	Soc. Head Screw
25.	A32900-020	Breaker (includes 18 & 19)
26.	A38071-022	Auger
27.	A32890-020	Evaporator
28.	03-1420-03	Cap Screw
29.	A32962-001	Insulation Bot. (half)

NME1850 & FME2400 SERVICE PARTS

FME Evaporator

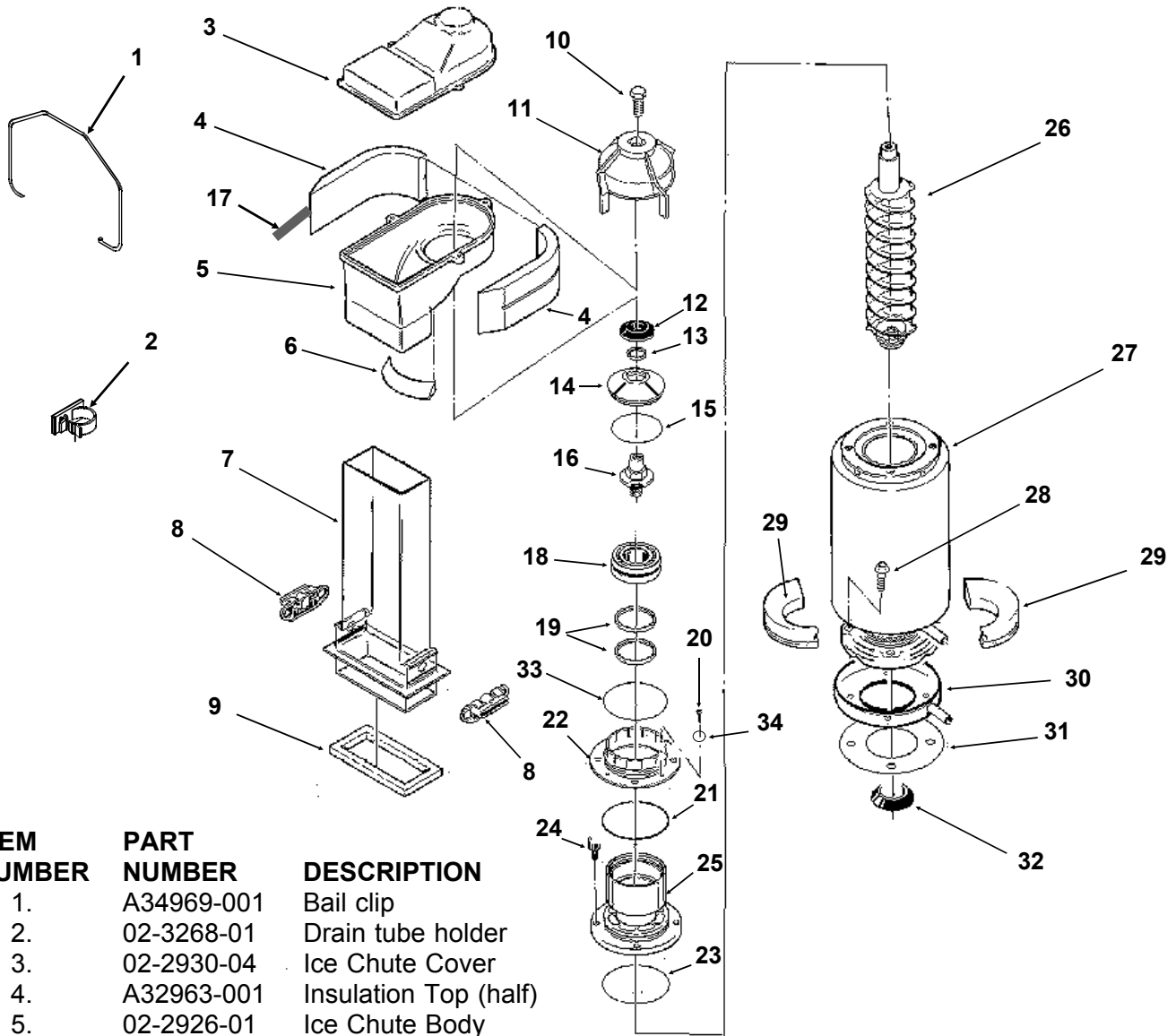

ITEM NUMBER	PART NUMBER	DESCRIPTION
1.	A34969-001	Bail clip
2.	02-3268-01	Drain tube holder
3.	02-2930-04	Ice Chute Cover
4.	A32963-001	Insulation Top (half)
5.	02-2926-01	Ice Chute Body
6.	A33102-001	Insulation Collar Inside
7.	02-2929-04	Ice Chute Lower
8.	A37708-021	Bin Controls Assy. (set of 2)
9.	A32930-001	Chute Gasket
10.	03-1405-52	Hex Cap Screw
11.	02-3001-01	Ice Sweep
12.	13-0871-01	Water Shed
13.	02-2978-01	Lip Seal
14.	02-3128-20	Breaker Cover
15.	13-0617-54	O-Ring
16.	08-0660-01	Auger Stud, thrust Washer
17.	A35419-020	Strap kit
18.	A34559-020	Bearing
19.	02-2977-01	Lip Seal
20.	03-1405-27	Screw
21.	13-0617-52	O-Ring
22.	02-2916-01	Slotted Collar
23.	13-0617-45	O-Ring
24.	03-1544-08	Soc. Head Screw
25.	A34505-020	Breaker (Divider) (includes 18 & 19)
26.	A38071-022	Auger
27.	A32890-020	Evaporator
28.	03-1420-03	Cap Screw
29.	A32962-001	Insulation Bot. (half)
30.	02-3837-01	Drip Pan
31.	13-0704-00	Drip Pan Gasket
32.	13-0868-01	Water Shed
33.	13-0617-49	O-Ring
34.	03-1408-36	Washer

NME1850 & FME2400 SERVICE PARTS

Control Box

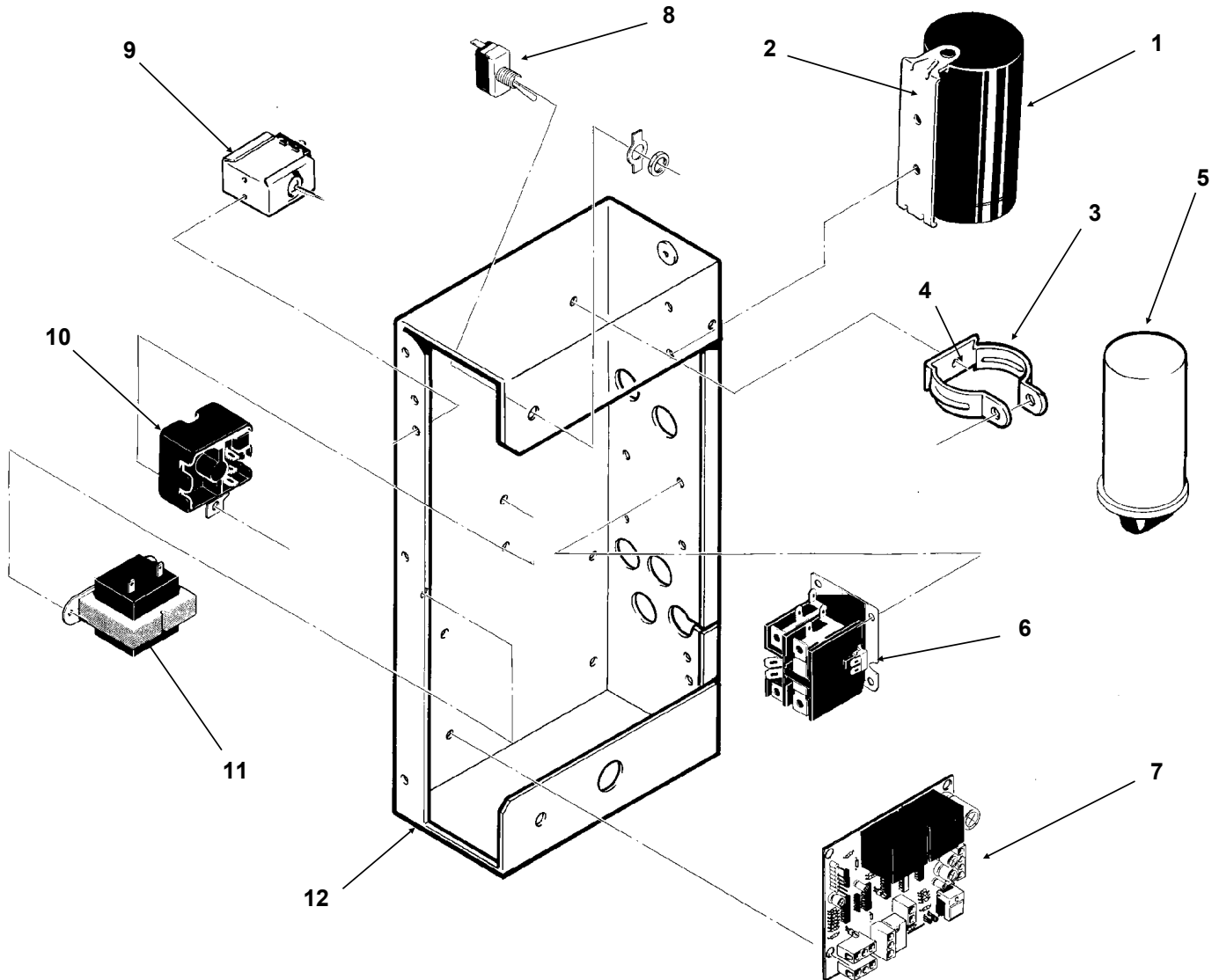

ITEM NUMBER	PART NUMBER	DESCRIPTION	ITEM NUMBER	PART NUMBER	DESCRIPTION
1	18-1901-54	Start Capacitor, 60 Hz	7	A37750-021	Circuit Board
	18-1901-53	Start capacitor, 50 Hz	8.	12-0426-01	Master Switch
	18-2200-38	Start Capacitor Cap.	9.	11-0447-20	Low Pressure Control
2.	18-2200-39	Start Capacitor Bracket	10	18-1903-33	Potential Relay 60 Hz
	03-1638-04	Screw		18-1903-29	Potential relay, 50 Hz
	03-1417-15	Lockwasher	11.	12-2285-22	Transformer
3.	A32872-001	Run Cap Bracket	12	no number	Control Box
	03-1652-02	Bolt			NOT ILLUSTRATED
	03-0255-04	Wing Nut	13.	12-2340-01	4 Pin Plug Assy
4.	03-1638-03	Screw			(Transformer to Circuit Board)
5.	18-1902-45	Run Capacitor, 60 Hz	14	A34055-001	Control Box Cover
	18-1902-53	Run capacitor, 50 Hz			
6.	12-2469-02	Single Phase Contactor			
	12-0739-02	Three Phase Contactor			

NME1850 & FME2400 SERVICE PARTS

AIR AND WATER COOLED, 208-230/60/1

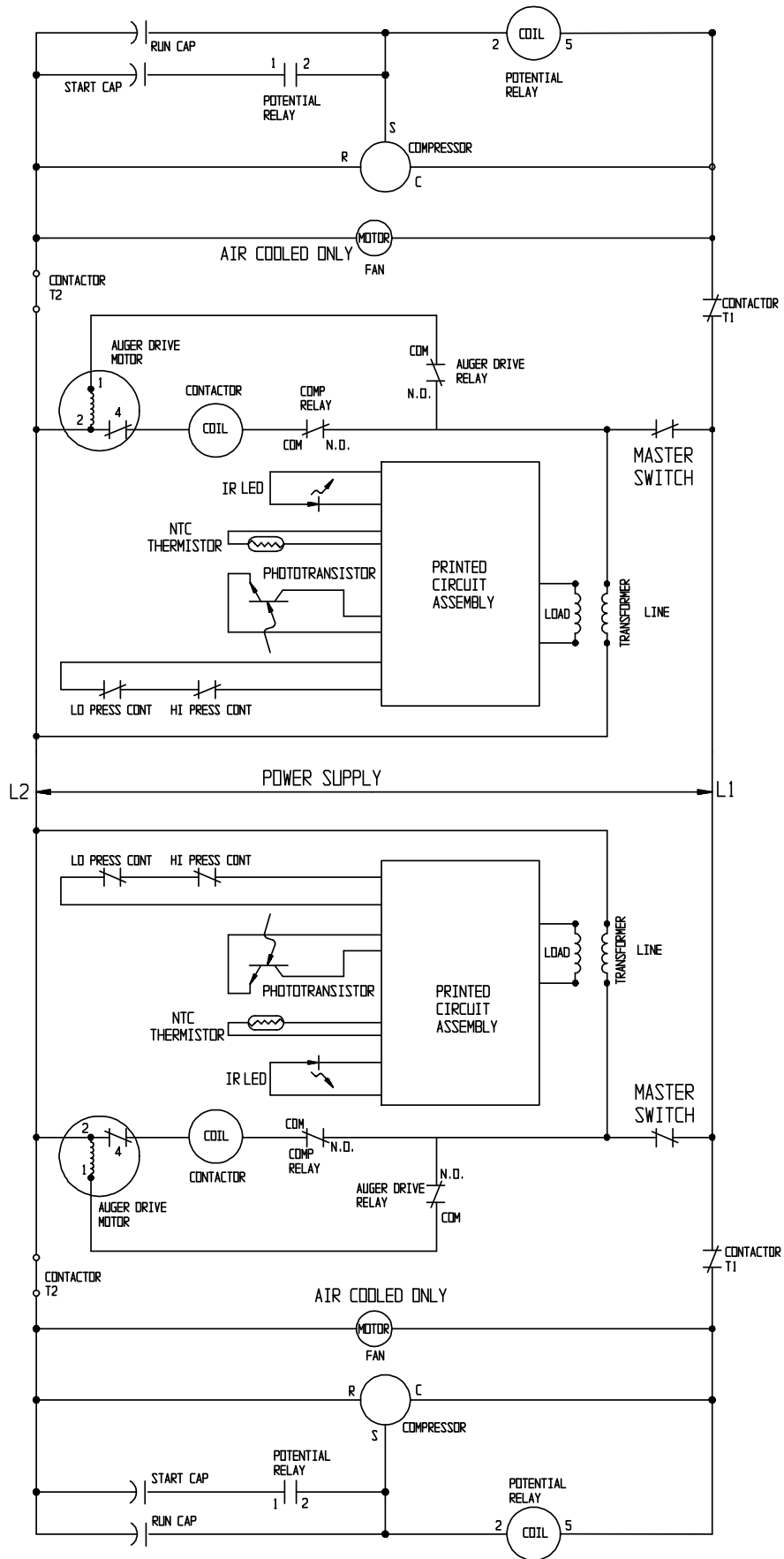

NME1850 & FME2400 SERVICE PARTS
AIR AND WATER COOLED, 208-230/60/1

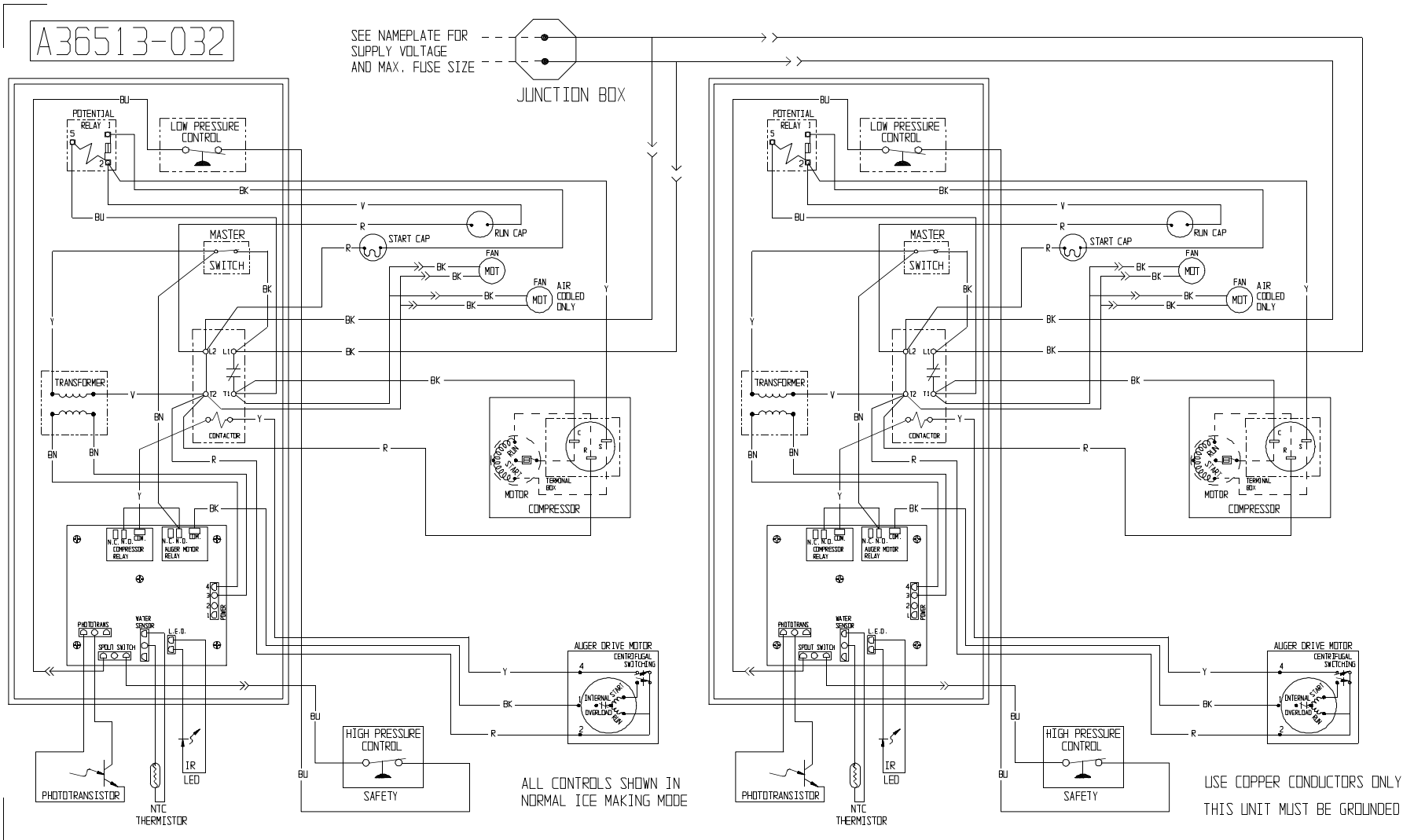

ALL CONTROLS SHOWN IN NORMAL ICE MAKING MODE

USE COPPER CONDUCTORS ONLY
THIS UNIT MUST BE GROUNDED

NME1850 & FME2400 SERVICE PARTS

AIR AND WATER COOLED, 208-230/60/3

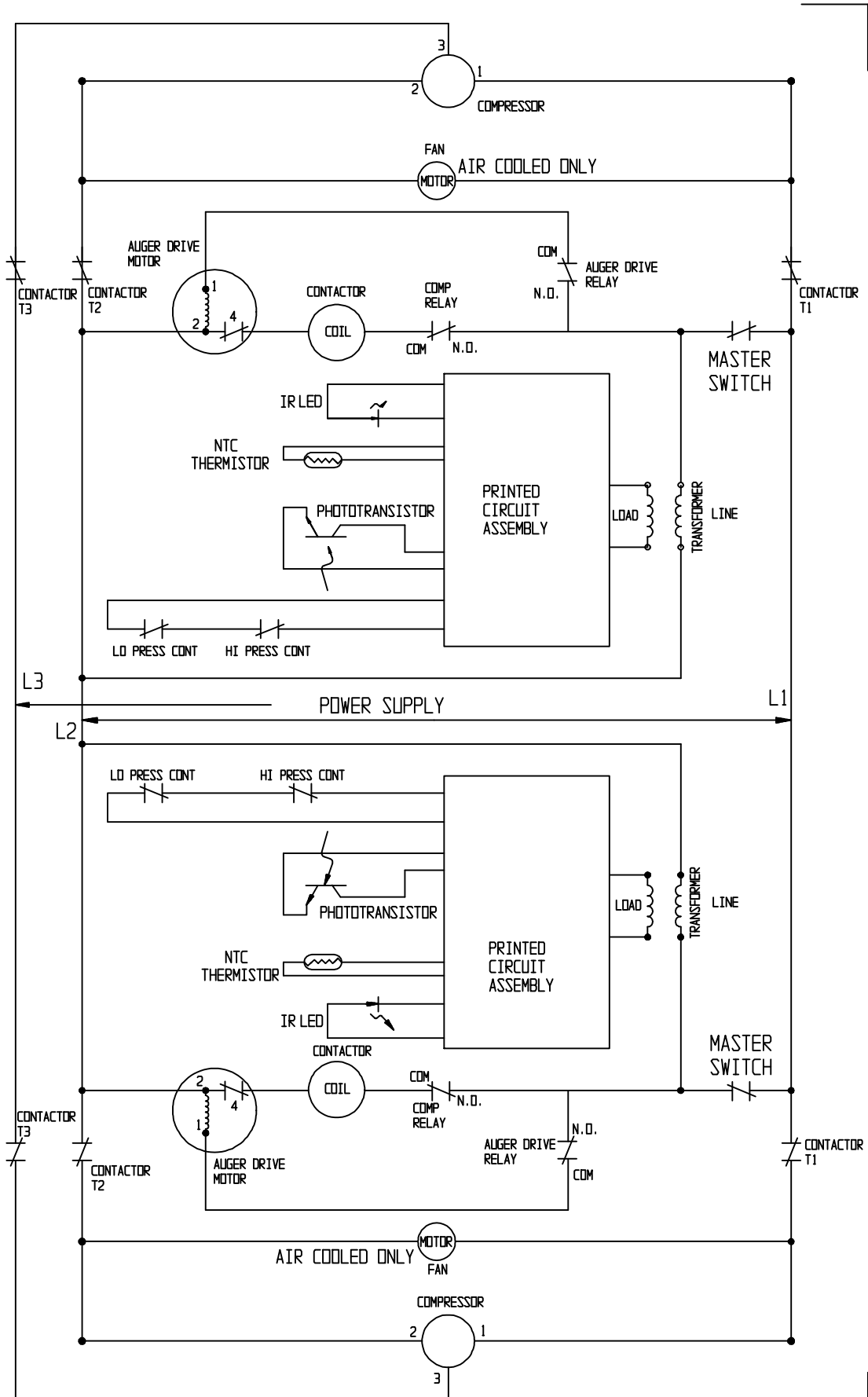

NME1850 & FME2400 SERVICE PARTS

AIR AND WATER COOLED,
208-230/60/3

A36513-003

SEE NAMEPLATE FOR
SUPPLY VOLTAGE
AND MAX. FUSE SIZE

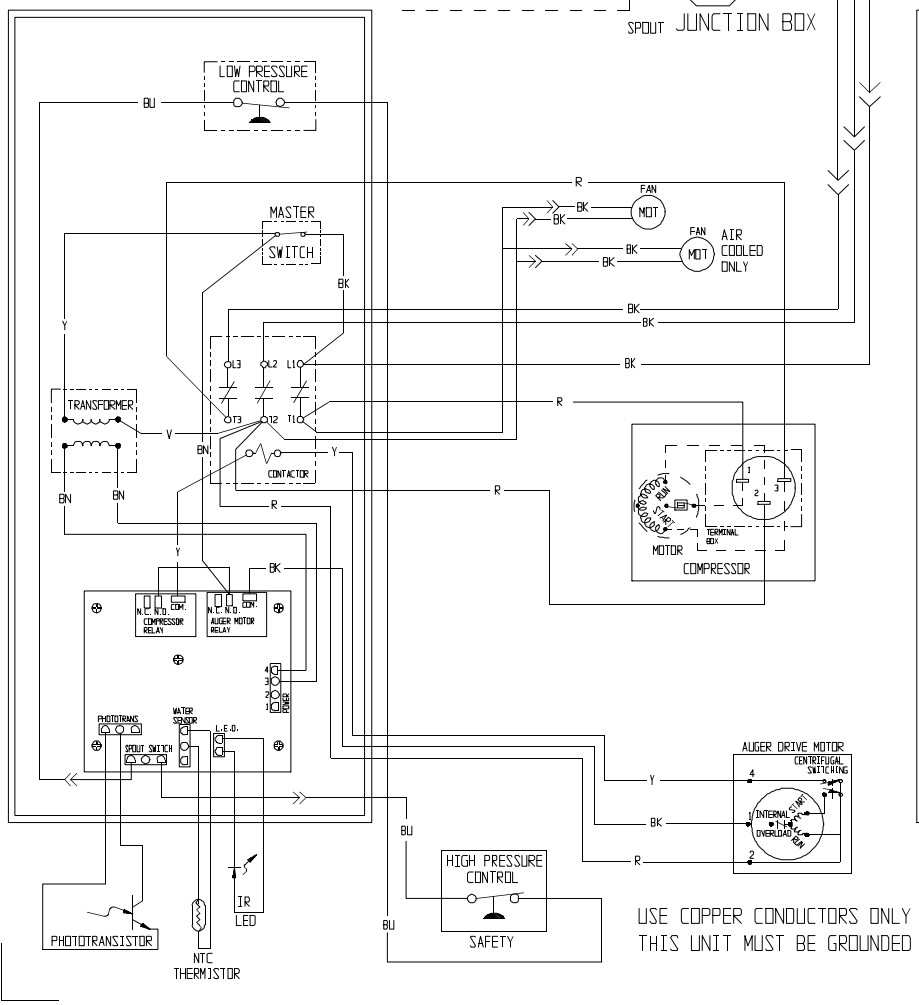
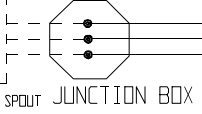

USE COPPER CONDUCTORS ONLY
THIS UNIT MUST BE GROUND

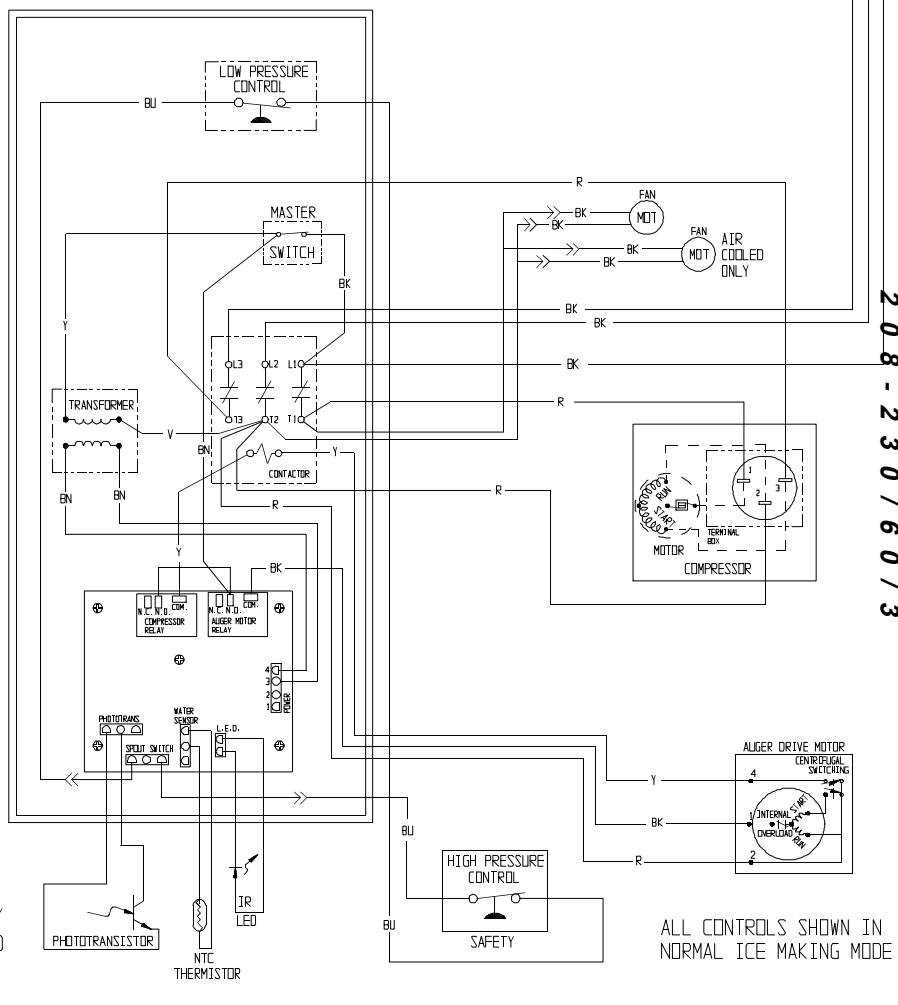

ALL CONTROLS SHOWN IN
NORMAL ICE MAKING MODE