

INTRODUCTION

To the owner or user: The service manual you are reading is intended to provide you, and the maintenance or service technician, with the information needed to install, start up, clean, maintain, and service either ice system.

The product is a remote condenser modular ice system. Its features include: front service for the freezer, gear motor, control box, water reservoir, and bin control; an electronic circuit for monitoring ice and water level; and R-404A as the refrigerant.

Table of Contents

FOR THE INSTALLER	Page 2
REMOTE CONDENSER SPECIFICATIONS	Page 3
FOR THE INSTALLER	Page 4
Remote Condenser Location	Page 5
FOR THE INSTALLER: Remote Condenser	Page 6
FOR THE INSTALLER: Precharged Lines	Page 7
FOR THE INSTALLER: Location	Page 8
FOR THE PLUMBER	Page 9
FOR THE ELECTRICIAN	Page 10
FOR THE INSTALLER: Completed Installation	Page 11
FOR THE INSTALLER: Final Check List	Page 12
START UP	Page 13
COMPONENT DESCRIPTION	Page 14
OPERATION: Water	Page 15
COMPONENT DESCRIPTION: Control Box	Page 16
ELECTRICAL SEQUENCE	Page 17
SYSTEM INFORMATION	Page 18
OPERATION: Refrigeration	Page 19
OPERATION: Refrigeration	Page 20
CLEANING and SANITATION	Page 21
SENSOR MAINTENANCE	Page 22
BEARING MAINTENANCE	Page 23
AUGER MAINTENANCE	Page 24
SERVICE DIAGNOSIS: Condition	Page 25
SERVICE DIAGNOSIS:	Page 26
CONTROL SYSTEM DIAGNOSTICS	Page 27
REMOVAL AND REPLACEMENT: Water Reservoir & Bin Controls	Page 28
REMOVAL AND REPLACEMENT: Bearing And Breaker	Page 29
REMOVAL AND REPLACEMENT: Auger	Page 30
REMOVAL AND REPLACEMENT: Water Seal	Page 31
REMOVAL AND REPLACEMENT: Evaporator	Page 32
REMOVAL AND REPLACEMENT: Gear motor Assembly	Page 33
REFRIGERATION SYSTEM SERVICE	Page 34
What to Do Before Calling for Service	Page 35

The manual was printed on recycled paper. Keep it for future reference.

Note the Warning symbol where it appears. It marks a possible hazard.



NME1854R & FME2404R

FOR THE INSTALLER

These machines are designed to fit the following Scotsman storage bins:

- B90 and extensions, with bin top KBT18.
- BH800 no bin top needed.
- BH900 using bin top KBT14.

When installing a new system, check to be sure that you have everything you need before beginning:

- Correct Bin
- Correct Ice Machine
- Correct Bin Top
- All kits, legs, and information required for the specific job.

TOP VIEW

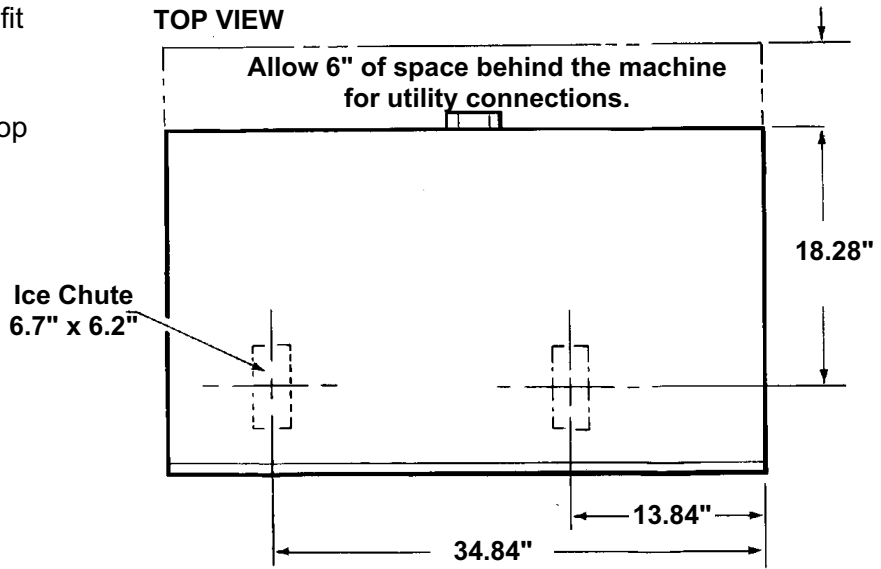

There are two separate ice making and refrigeration systems in this model. The liquid and discharge lines from each system must go to separate circuits in one remote condenser (ERC302).

BACK VIEW

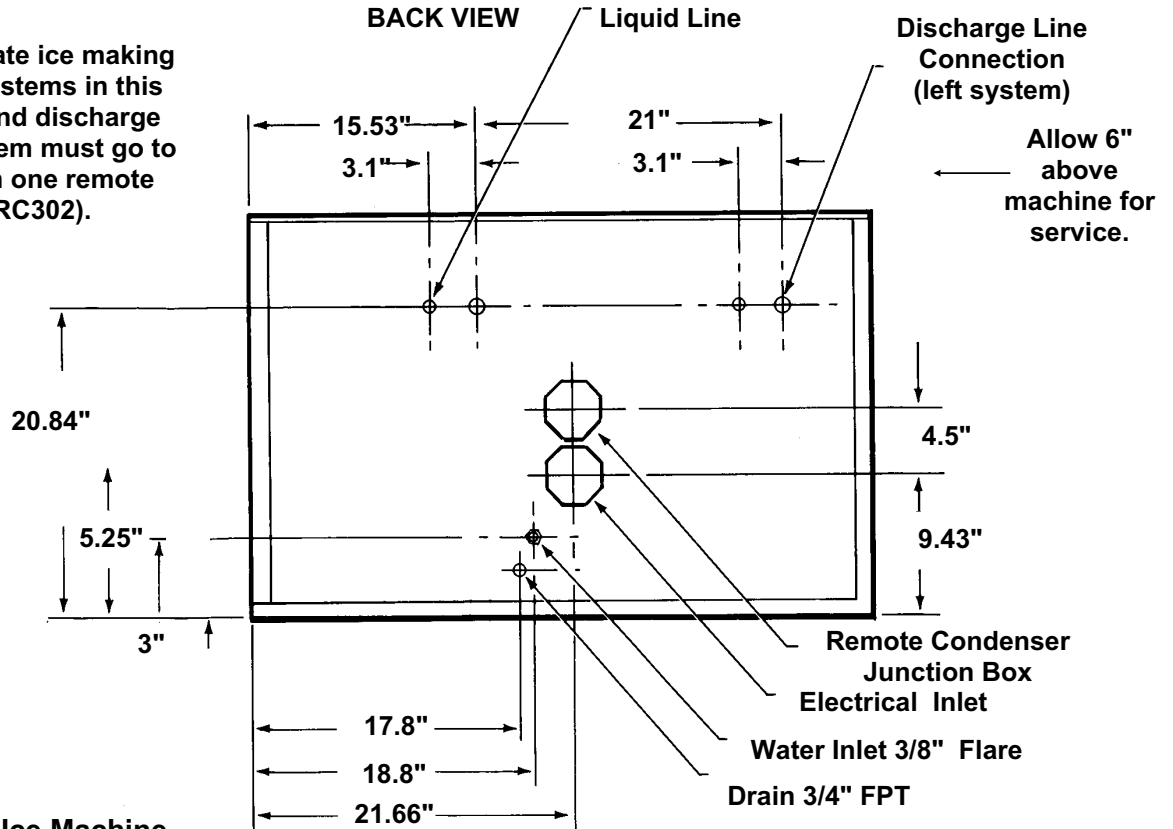

SPECIFICATIONS: Ice Machine

Model Number	Dimensions (w/o bin)	Basic Electrical	Ice Type	Cond. Type	Minimum Circuit Ampacity	Maximum Fuse Size	Refrigerant Charge
	H X W X D						
FME2404RS-32A	27" x 42" x 24"	208-230/60/1	FLAKE	R-Air	22.8	30	208
FME2404RS-3A	27" x 42" x 24"	208-230/60/3	FLAKE	R-Air	17.6	20	208
NME1854RS-32A	27" x 42" x 24"	208-230/60/1	Nugget	R-Air	22.8	30	208
NME1854RS-3A	27" x 42" x 24"	208-230/60/3	Nugget	R-Air			

Minimum circuit ampacity is used to determine wire size and type per National Electrical Code.

January 2000

NME1854R & FME2404R

REMOTE CONDENSER SPECIFICATIONS

Model	Use with	Basic Electrical
ERC302-32	1 FME2404R or NME1854R	208-230/60/1

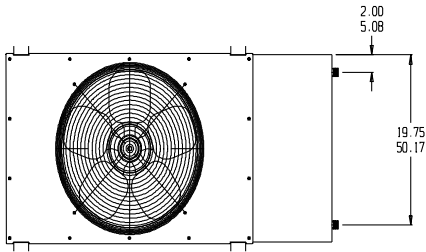

ERC DIMENSIONS

Model	A	B	F	G
ERC302	43 $\frac{3}{8}$ "	10 $\frac{3}{4}$ "	21 $\frac{3}{4}$ "	16 $\frac{5}{8}$ "

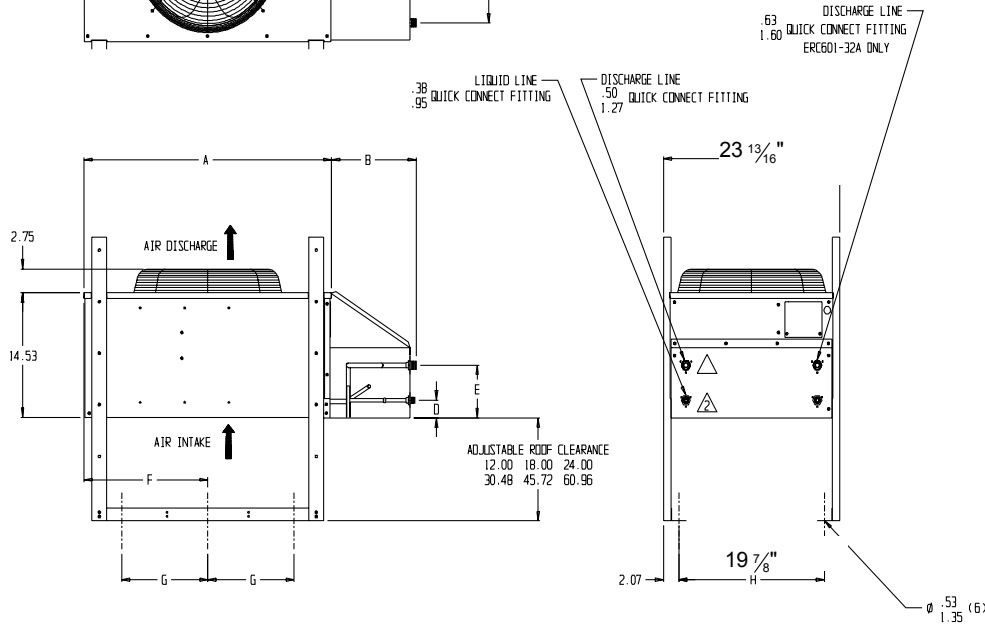

Other Required Items:

RTE25 Precharged line set, 25', R-404A - 2 required.

Or: RTE40. Precharged line set, 40', R-404A - 2 required.

MODEL NUMBER
SERIAL NUMBER
A.C. SUPPLY VOLTAGE
MINIMUM CIRCUIT AMPACITY
MAXIMUM FUSE SIZE *
HEATER WATTS
REFRIGERANT **CHARGE** **OZ.**
MOTORS **VOLTS** **RLA/FLA W/HP.** **LRA**
COMPRESSOR
FAN
DRIVE
OTHER
DESIGN PRESSURE **LOW** **HIGH**
 * OR HACR TYPE CIRCUIT BREAKER

SCOTSMAN
 FAIRFAX OPERATION
 FAIRFAX, SOUTH CAROLINA U.S.A.

**Ice Machine NAMEPLATE
LOCATED ON BACK PANEL**

**SERIAL PLATE LOCATED
BEHIND FRONT PANEL**

**REMOTE CONDENSERS AND BINS ALSO
HAVE MODEL AND SERIAL NUMBERS**

NME1854R & FME2404R

FOR THE INSTALLER

Installation Limitations:

This ice system is designed to be installed indoors, in a controlled environment:

	Min	Max
Air Temperature (Not including the remote condenser)	50°F	100°F
Water Temperature	40°F	100°F
Water Pressure (psi)	20	80
Voltage	198	253

(Compared to the nameplate)

Operating the machine outside of the limitations is misuse and can void the warranty.

Water Limitations:

An ice machine is a food manufacturing plant; it takes a raw material, water, and turns it into a food product, ice. The purity of the water is very important in obtaining pure ice and in maximizing product life. This is not intended as a complete resource for water related questions, but it does offer these general recommendations:

1. Check with a water treatment specialist for a water test, and recommendations regarding filters and treatment.
2. In most cases, the water used to make ice should be filtered or treated, depending upon the water. *There is no one type of water filter that will be effective in all situations.* That is why a water test is important.

Scotsman Ice Systems are designed and manufactured with the highest regard for safety and performance. They meet or exceed the standards of UL, NSF, and CUL.

Scotsman assumes no liability or responsibility of any kind for products manufactured by Scotsman that have been altered in any way, including the use of any part and/or other components not specifically approved by Scotsman.

Scotsman reserves the right to make design changes and/or improvements at any time. Specifications and design are subject to change without notice.

Location

Install the machine a location where it has enough space around it to be accessible for service, usually a minimum of 6 inches. Avoid hot, dirty and crowded locations. Be sure that the location for the machine is within its limitations for air and water temperatures.

Storage Bin

Tip the storage bin on its back, using parts of the carton to protect the exterior finish. Install the legs into the threaded holes in the bottom of the bin. Turn the leg levelers all the way in preparation for leveling later. Return the bin to the upright position, remove paper covering the bin gasket. Install the bin top according to the directions with the bin top.

Note: Do not push bin into position, instead lift it there. Pushing a bin, especially one with ice in it, can cause damage to the legs and the leg mounts.

Ice Machine

The machine is heavy, so the use of a mechanical lift is recommended for lifting the machine high enough to install on top of the bin. After the unit is placed on the bin, line it up so it is even with the back side. Secure the machine to the bin with the hardware provided with the machine.

Remove the front panel and remove any shipping blocks.

Note: Be sure to allow a 6" minimum space above the top of the machine for service.

Remote Condenser Location

Use the following for planning the placement of the condenser relative to the ice machine

Location Limits - condenser location must not exceed ANY of the following limits:

- Maximum rise from the ice machine to the condenser is **35 physical feet**
- Maximum drop from the ice machine to the condenser is **15 physical feet**
- Physical line set maximum length is **100 feet**.
- Calculated line set length maximum is **150**.

Calculation Formula:

- Drop = $dd \times 6.6$ (dd = distance in feet)
- Rise = $rd \times 1.7$ (rd = distance in feet)
- Horizontal Run = $hd \times 1$ (hd = distance in feet)
- Calculation: Drop(s) + Rise(s) + Horizontal Run = $dd+rd+hd$ = Calculated Line Length

Configurations that do NOT meet these requirements must receive prior written authorization from Scotsman.

Do NOT:

- Route a line set that rises, then falls, then rises.
- Route a line set that falls, then rises, then falls.

Calculation Example 1:

The condenser is to be located 5 feet below the ice machine and then 20 feet away horizontally.

$5 \text{ feet} \times 6.6 = 33$. $33 + 20 = 53$. *This location would be acceptable*

Calculation Example 2:

The condenser is to be located 35 feet above and then 100 feet away horizontally.

$35 \times 1.7 = 59.5$. $59.5 + 100 = 159.5$. *159.5 is greater than the 150 maximum and is NOT acceptable.*

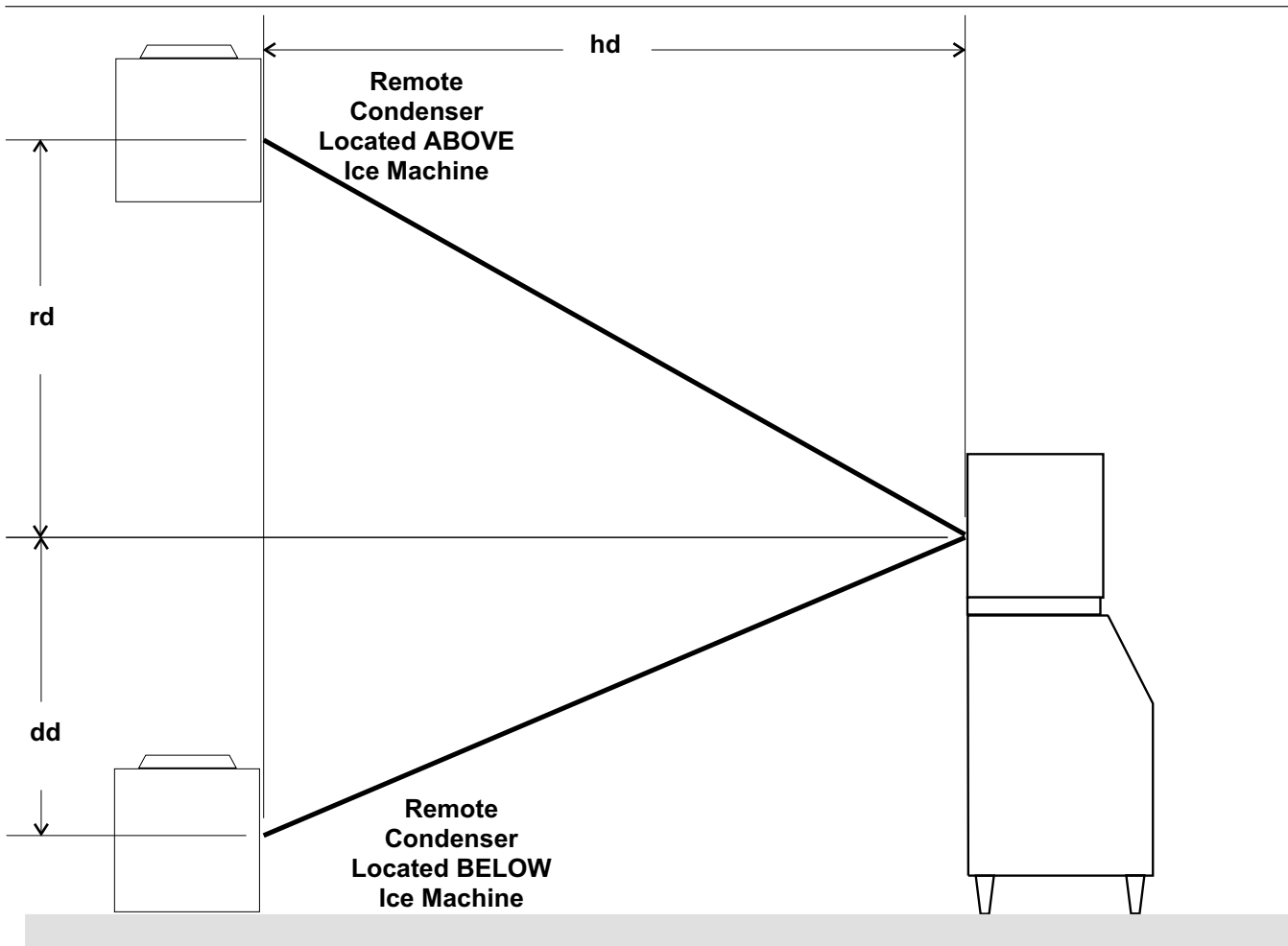

NME1854R & FME2404R

FOR THE INSTALLER: Remote Condenser

Location

Select the best available location, protecting the condenser from extremes of dirt, dust, and sun. Meet all applicable building codes. Usually the services of a licensed electrician are required.

Roof Attachment

1. Install and attach the remote condenser to the roof of the building, using the methods and practices of construction that conform to the local building codes, including having a roofing contractor secure the condenser to the roof.
2. Have an electrician connect the remote condenser fan motor to the Ice Machine, using the junction box at the back of the Ice Machine.

PRECHARGED LINE ROUTING

CAUTION

Do not connect precharged tubing until all routing and forming of the tubing is complete. See the coupling instructions for connecting information.

1. Each set of precharged refrigerant lines (either 25 foot or 40 foot) consists of a 3/8 inch diameter liquid line and a 1/2 inch diameter discharge line. Both ends of each line have quick connect couplings, one end has a schrader valve connection, that end goes to the condenser.

Note: The openings in the building ceiling or wall, listed in the next step, are the minimum sizes recommended for passing the refrigerant lines through.

2. Have the roofing contractor cut a minimum hole for the refrigerant lines of 1 3/4 inch. Check local codes, a separate hole may be required for the electrical power to the condenser.

CAUTION

DO NOT KINK OR CRIMP REFRIGERANT TUBING WHEN INSTALLING IT.

3. Route the refrigerant lines through the roof opening. Follow straight line routing whenever possible. Any excess tubing **MUST** be retained within the building.
4. Spiral the excess length of pre charged tubing inside the building. Use a horizontal spiral (as illustrated) to avoid any traps in the lines.
5. Have the roofing contractor seal the holes in the roof per local codes.

Note: Precharged tubing contains a R-404A holding charge. The entire refrigerant charge required for the system is contained in the ice machine.

Tubing illustration shows tight spiral; a spiral in the field depends on tubing limitations. Tight spiral not required.

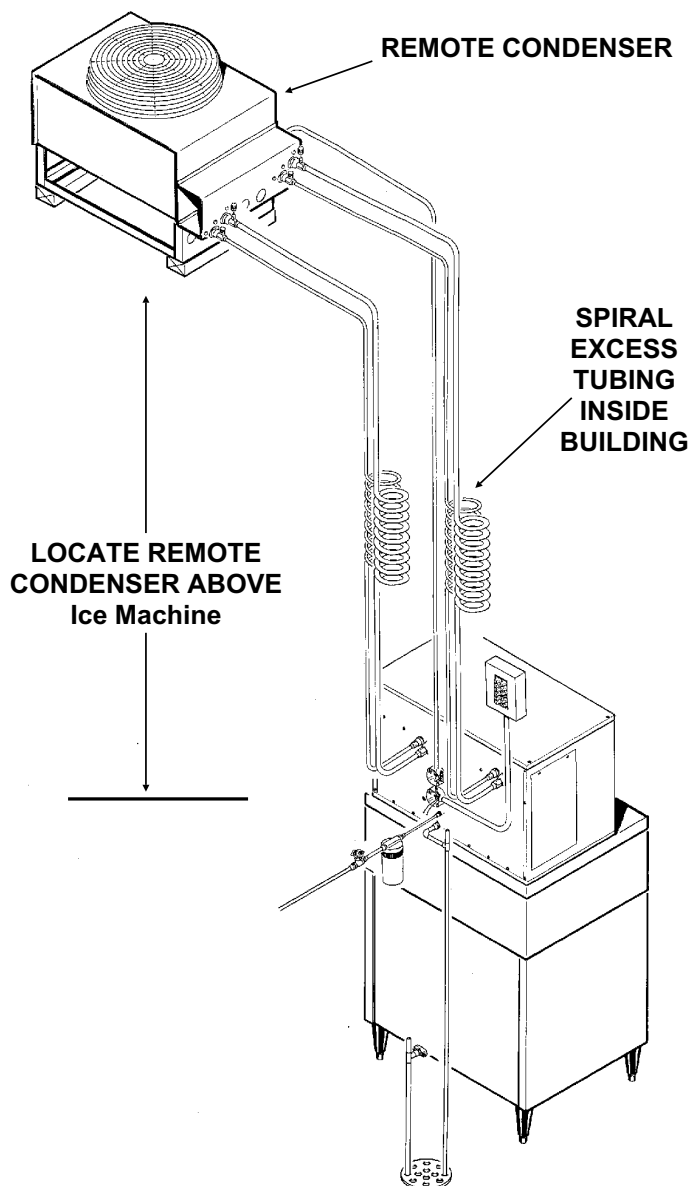

FOR THE INSTALLER: Precharged Lines

Note: The couplings on the sets of precharged lines must be installed properly to prevent leaking. Carefully follow the instructions:

Initial Connections:

1. Remove the protector caps and plugs. Wipe the seats and threaded surfaces with a clean cloth to be certain that no foreign matter remains on them.
2. Lubricate the inside of the couplings, especially the O-Rings with refrigerant oil.

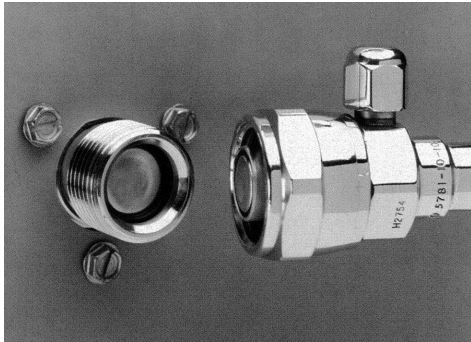

Clean and Lubricate Couplings

3. Position the fittings on the correct connections on the condenser and ice machine.

- The 1/2 inch discharge line (schrader valve end) goes to the remote condenser fitting marked "discharge line."
- The 3/8 inch liquid line (schrader valve end) goes to the remote condenser fitting marked "liquid line."
- The 1/2 inch discharge line goes to the Ice Machine fitting marked "discharge line."
- The 3/8 inch liquid line goes to the Ice Machine fitting marked "liquid line."

Final Connections:

- 4a. Begin by tightening the couplings together by hand. Continue to turn the swivel nuts by hand until it is certain that the threads are properly engaged.

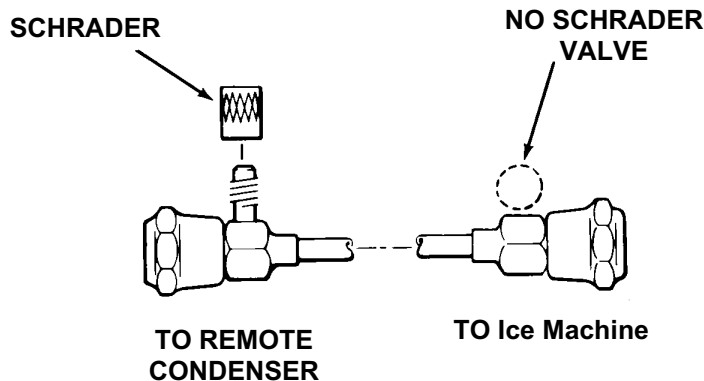

- 4b. Using two wrenches, one to rotate the swivel nut and one to hold the tubing, tighten each coupling.

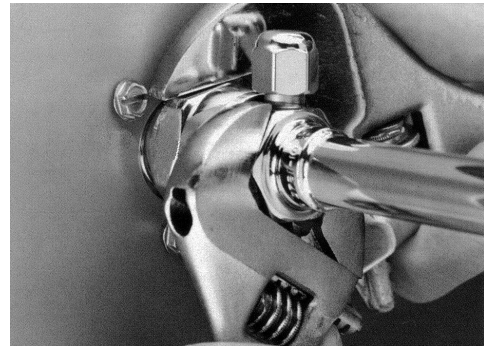

Tighten Swivel Nut

It is CRITICAL that ONLY the NUT on the pre-charged tube be turned or the diaphragms will be torn loose by the piercing knives and be loose in the refrigeration system causing severe operational problems.

Note: As the coupling is tightened, the diaphragms in the quick connect couplings will begin to be pierced. As that happens, there will be increased resistance to tightening the swivel nut.

- 4c. Continue tightening the swivel nut until it bottoms out or a very definite increase in resistance is felt (no threads should be showing). Do NOT overtighten.

5. Using a marker or pen, mark a line lengthwise from the coupling union nut to the bulkhead. Then tighten the coupling and additional 1/4 turn. As the nut turns, the line will show when 1/4 turn is made.

6. After all connections are made, and after the king valve has been opened (do not open at this time), check the couplings for leaks.

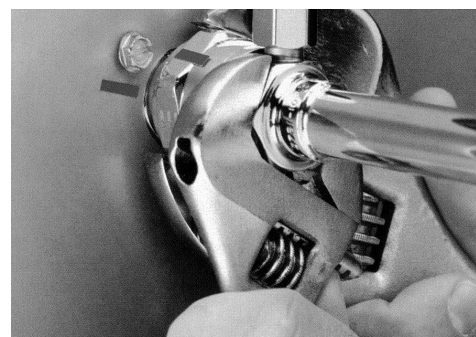

Rotate Swivel Nut 1/4 Turn More

NME1854R & FME2404R

FOR THE INSTALLER: Location

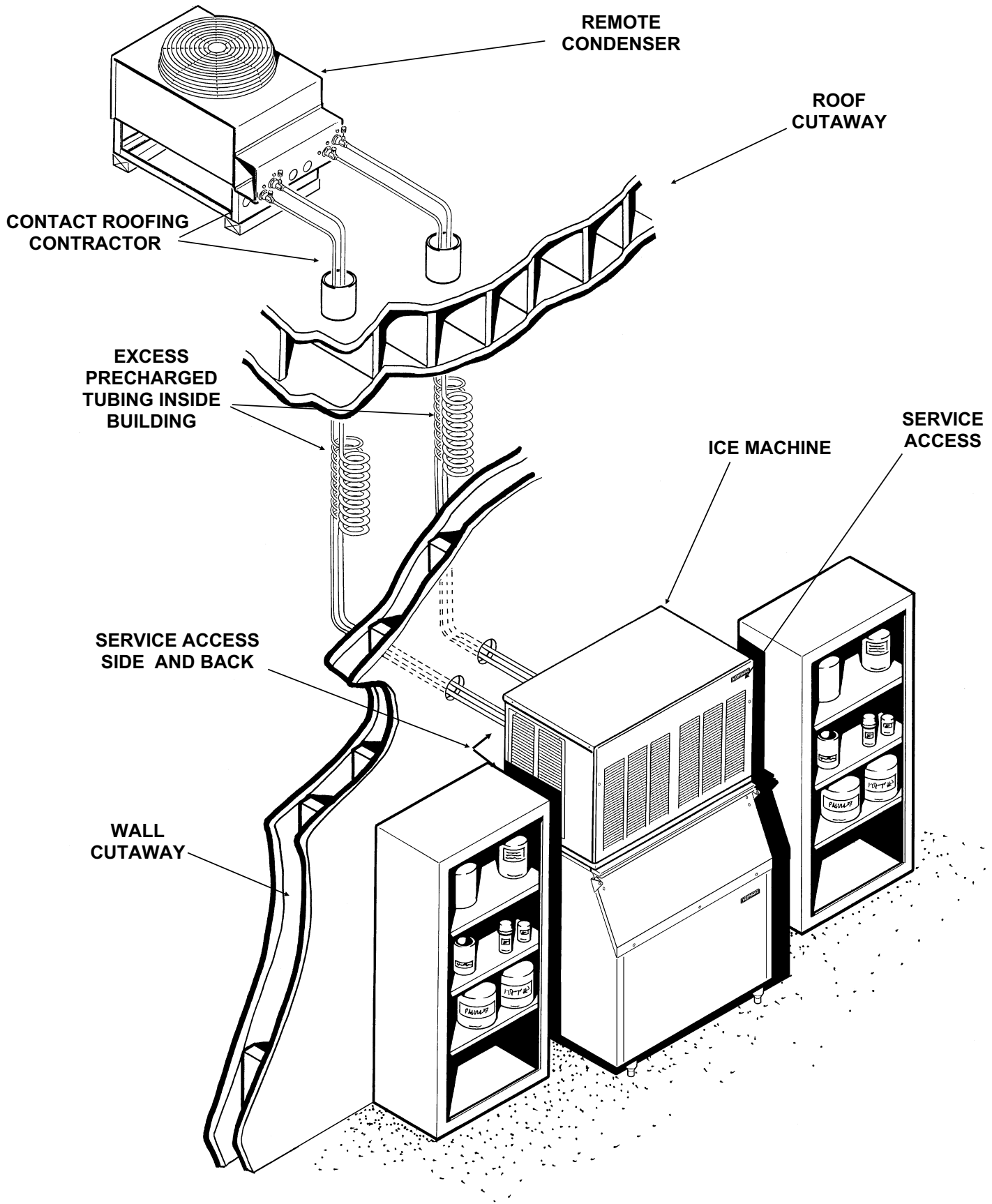

FOR THE PLUMBER

CONFORM TO ALL APPLICABLE CODES

Water Inlet

Connect the ice machine to cold potable water. Use 3/8" O.D. copper tubing, and connect to the 3/8" male flare at the back of the cabinet. Install a hand valve near the machine to control the water supply.

Drains

There is one 3/4" FPT drain at the back of the cabinet, the drain line is of the gravity type, and 1/4 inch per foot fall is an acceptable pitch for the drain tubing. Install a vent at the highest point of the drain line, and the ideal drain receptacle would be a trapped and vented floor drain.

Use only 3/4" rigid tubing.

Storage Bin: Install a separate gravity type drain. Insulation of this drain line is recommended.

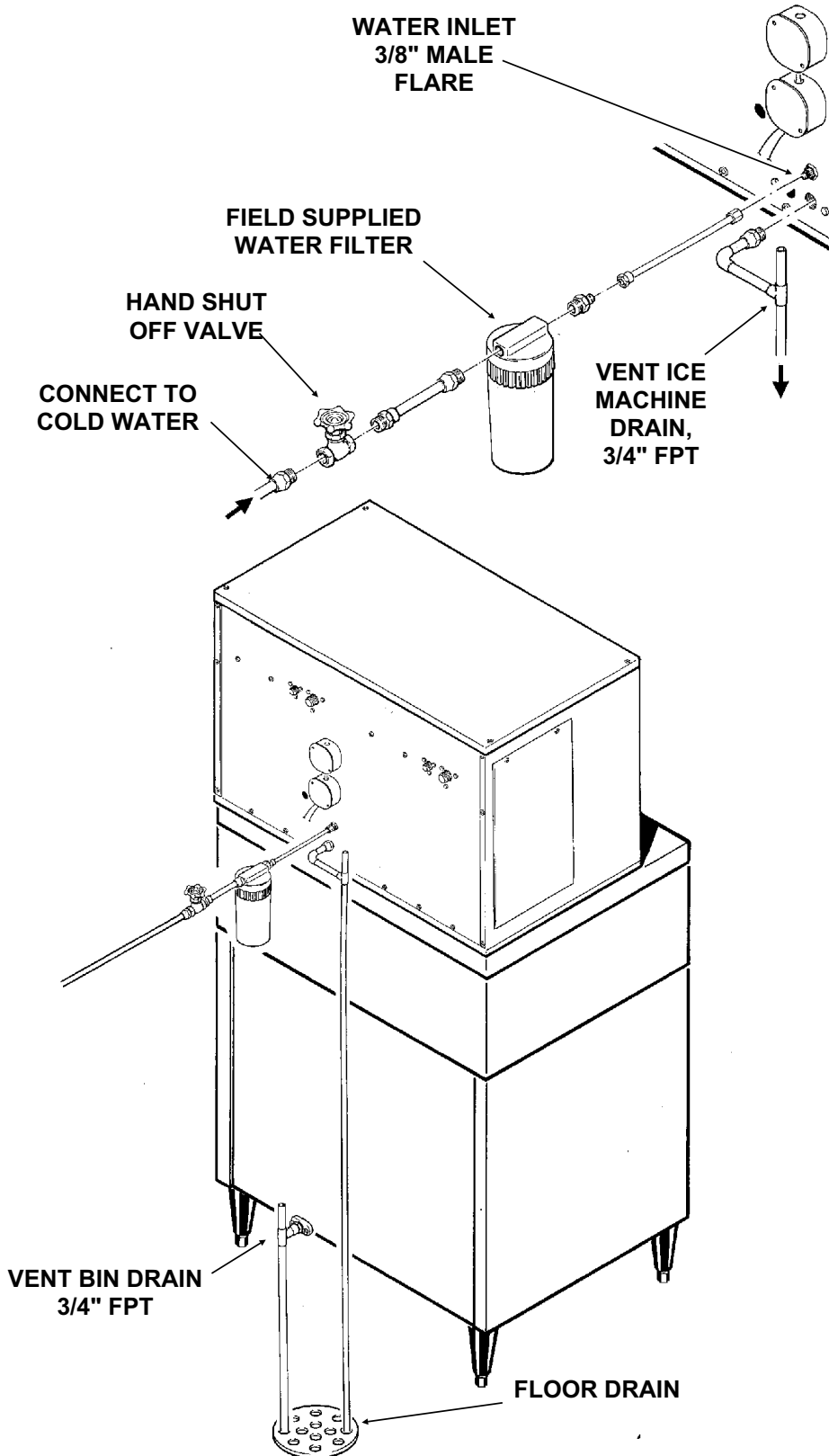

NME1854R & FME2404R

FOR THE ELECTRICIAN

CONFORM TO ALL APPLICABLE CODES

Connect electrical power to the wires in the junction box at the rear of the machine. Check the nameplate (located on the back panel) for the voltage requirements, and for the minimum circuit ampacity. The machine requires a solid chassis to earth ground wire.

The Ice Machine should be connected to its own electrical circuit so it would be individually fused. Voltage variation must remain within design limitations, even under starting conditions.

Electrically the remote condenser fan motor is connected to the Ice Machine at the contactor terminals for the compressor and the fan motor operates whenever the compressor operates.

Electrical connections are made at the junction box at the back of the Ice Machine and at the junction box on the remote condenser.

The remote condenser must be wired to the Ice Machine in accordance with local and national electrical codes with a minimum of 18 Awg. wire with an ground bonding wire connected to the ground screws provided in both the condenser and machine field wiring boxes. All outdoor wiring must be in rain proof conduit.

All external wiring must conform to national, state, and local electrical codes. The use of a licensed electrician is required to perform the electrical installation.

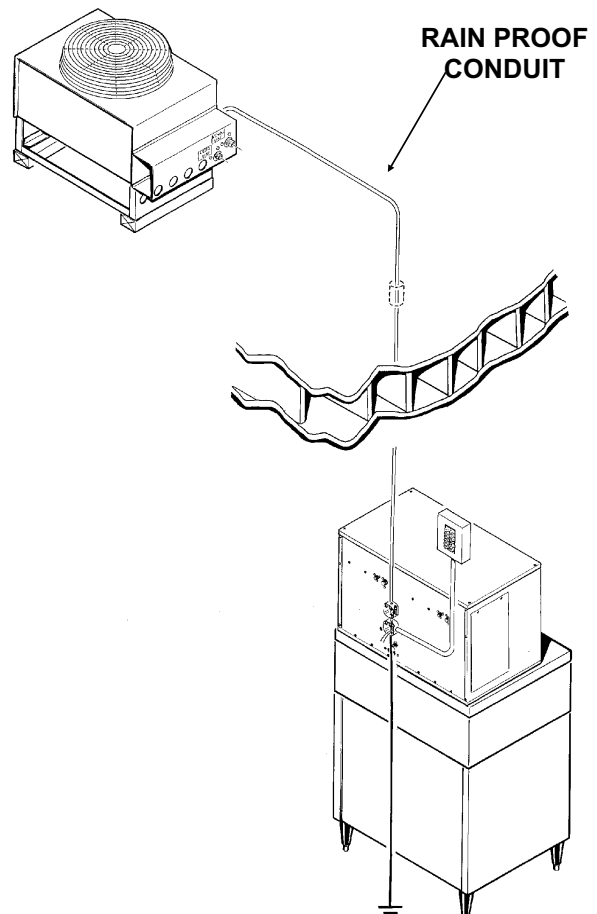
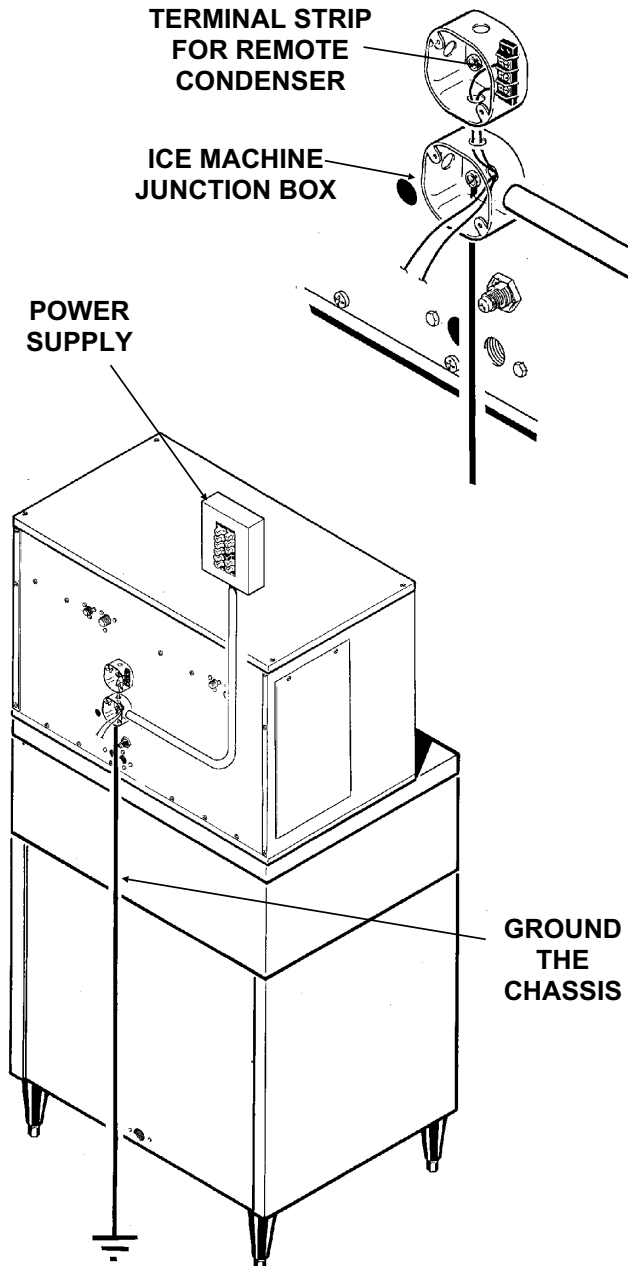

NME1854R & FME2404R

FOR THE INSTALLER: Completed Installation

A typical installation should generally appear as illustrated below. The remote condenser must be located above the Ice Machine and the precharged lines installed per the instructions on page 6.

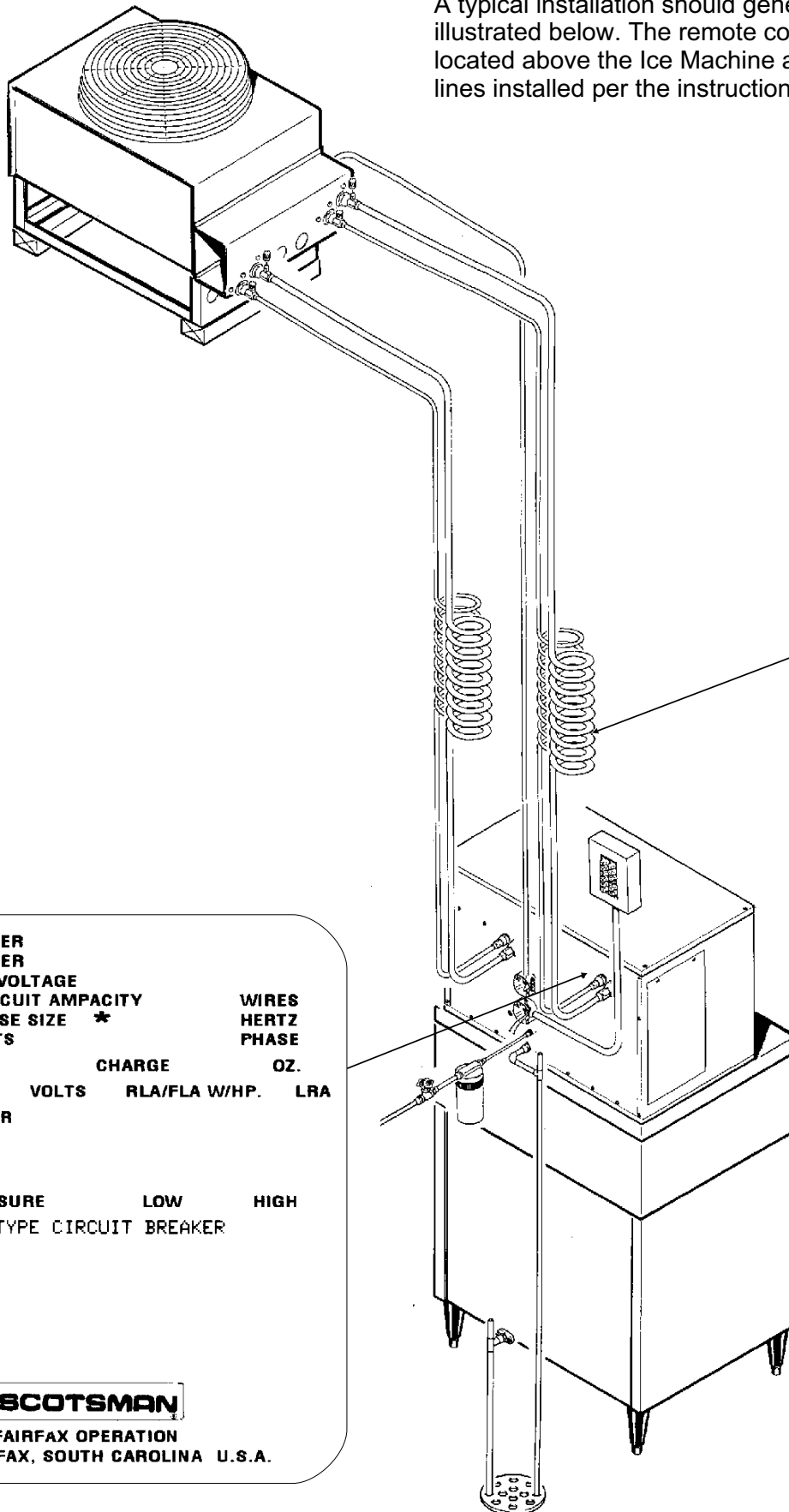

INSULATED
PRECHARGED
REFRIGERANT
TUBING

MODEL NUMBER			
SERIAL NUMBER			
A.C. SUPPLY VOLTAGE			
MINIMUM CIRCUIT AMPACITY			
MAXIMUM FUSE SIZE *			WIRES
HEATER WATTS			HERTZ
REFRIGERANT	CHARGE		PHASE
MOTORS	VOLTS	RLA/FLA W/HP.	LRA
COMPRESSOR			
FAN			
DRIVE			
OTHER			
DESIGN PRESSURE	LOW		HIGH
* OR HACR TYPE CIRCUIT BREAKER			

SCOTSMAN

FAIRFAX OPERATION
FAIRFAX, SOUTH CAROLINA U.S.A.

NME1854R & FME2404R

FOR THE INSTALLER: Final Check List

1. Is the ice system installed indoors in a location where the air and water temperatures are controlled, and where they do not exceed the design limitations?
2. Is there an electrical service disconnect within sight of the installed machine? Has the voltage been checked, and compared to nameplate requirements?
3. Have all the plumbing connections been made and checked for leaks?
4. Has the machine and bin been leveled?
5. Is there a minimum of 6" clearance at the rear, left, right and above the machine for proper service access?
6. Is the water pressure a minimum of 20 psig?
7. Has the machine been secured to the bin?
8. Is there a water shut off valve installed near the machine?
9. Is the remote condenser installed per local building codes, and in a place where it has adequate ventilation and minimal solar heat gain?
10. Has all shipping material and literature (inside the front panel) been removed from the units?
11. Have the remote condenser and precharged lines been properly installed?
12. Has the electrical connection between the Ice Machine and the condenser been made?
13. Verify that the master switches are in the OFF position.
14. Switch on the electrical power.
15. Refer to Pre-Start instructions, the next page.

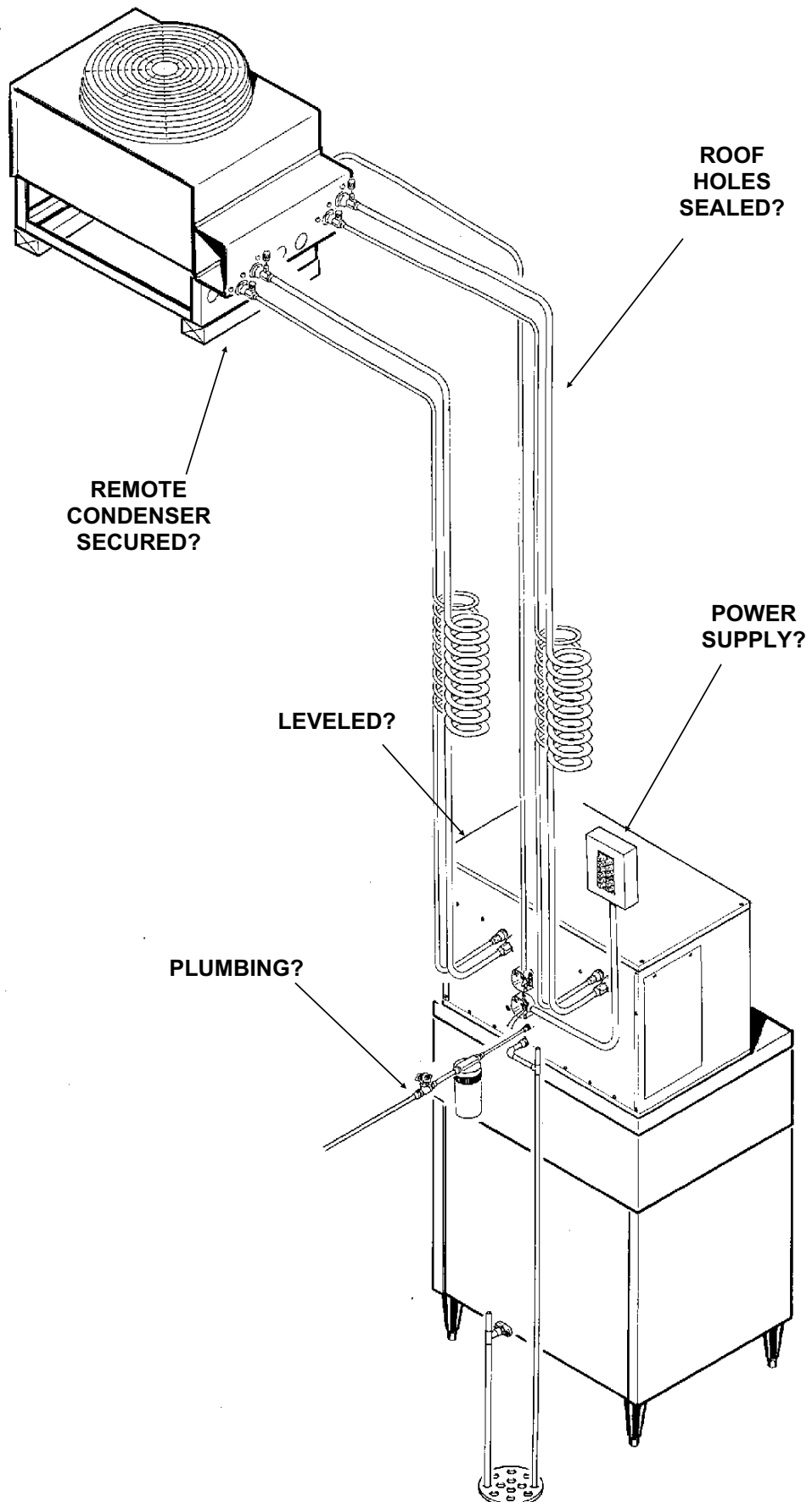

START UP

Pre-Start Inspection

1. Remove the front, left, and right side service panels.
2. Check that any shipping blocks have been removed.
3. Inspect the interior of the machine for loose screws or wires. Check that no refrigerant lines are rubbing each other. Check that the fan blade turns freely (remote condenser).
4. Check that the refrigerant lines are properly installed.
5. Check that the electrical power has been on for at least 4 hours and that the compressor domes are warm.
6. Check that the unit is installed correctly according to the final check list on page 12.

Start Up

1. Go through the pre-start inspection.
2. Open the hand valve, observe that water enters the water reservoirs, fills the tubes from the reservoirs to the evaporators, and then shuts off. Check for leaks.
3. Open each King (receiver service) valve.
4. Switch each master switch on.
The electrical start up sequence is automatic. There will be a short (15 second) delay before the gear motor starts and the liquid line valve opens, after that the low pressure control will close and the compressor will start.
5. The remote condenser fan turns, and the condenser begins to discharge warm air.
6. The unit should soon be making ice, if desired the low side pressure of each system can be checked, it should be 32 psig + or - 2 psig. The discharge pressure will depend upon air and water temperatures, but should be between 205 psig and 280 psig.
7. **THERE ARE NO ADJUSTMENTS TO MAKE**, so replace the panels.
8. Clean and/or sanitize the storage bin interior, wipe off the exterior with a clean, damp cloth.
- 9 Give the owner/user the service manual, instruct him/her in the operation of the unit, and make sure they know who to call for service.
10. Fill out the manufacturer's registration and mail it to Scotsman.

NME1854R & FME2404R

COMPONENT DESCRIPTION

Control Box: Contains the electrical controls that operate the machine.

High Pressure Cut Out: An automatic reset switch sensing the high side refrigeration pressure. It is set to shut the machine off at 450 psig.

Pump Down Control: An automatic reset pressure switch connected to the low side of the refrigeration system. Controls the compressor.

Evaporator: A vertical stainless steel tube, refrigerated, and water filled. In it, there is a stainless steel auger.

Reservoir: Float operated, it maintains the water level in the evaporator at a constant level, it also contains the water level sensor.

Water Level Sensor: Senses if there is water in the reservoir to make ice out of. Will shut the machine off if there is none.

Ice Discharge Chute: Directs the ice produced by the evaporator into the storage bin.

Ice Level Sensor: An electronic "eye", it senses the presence of ice in the bottom of the ice discharge chute. Operates to turn the ice machine on and off automatically as the level of ice in the bin changes.

Gear Motor: An oil filled, speed reduction gearbox, driving the auger.

Cleaning Drain Tube: When uncapped and lowered, drains the evaporator.

Compressor: The refrigerant vapor pump.

Expansion valve: The refrigerant metering device.

NOTE: THERE ARE TWO OF EACH OF THE LISTED COMPONENTS IN EACH UNIT

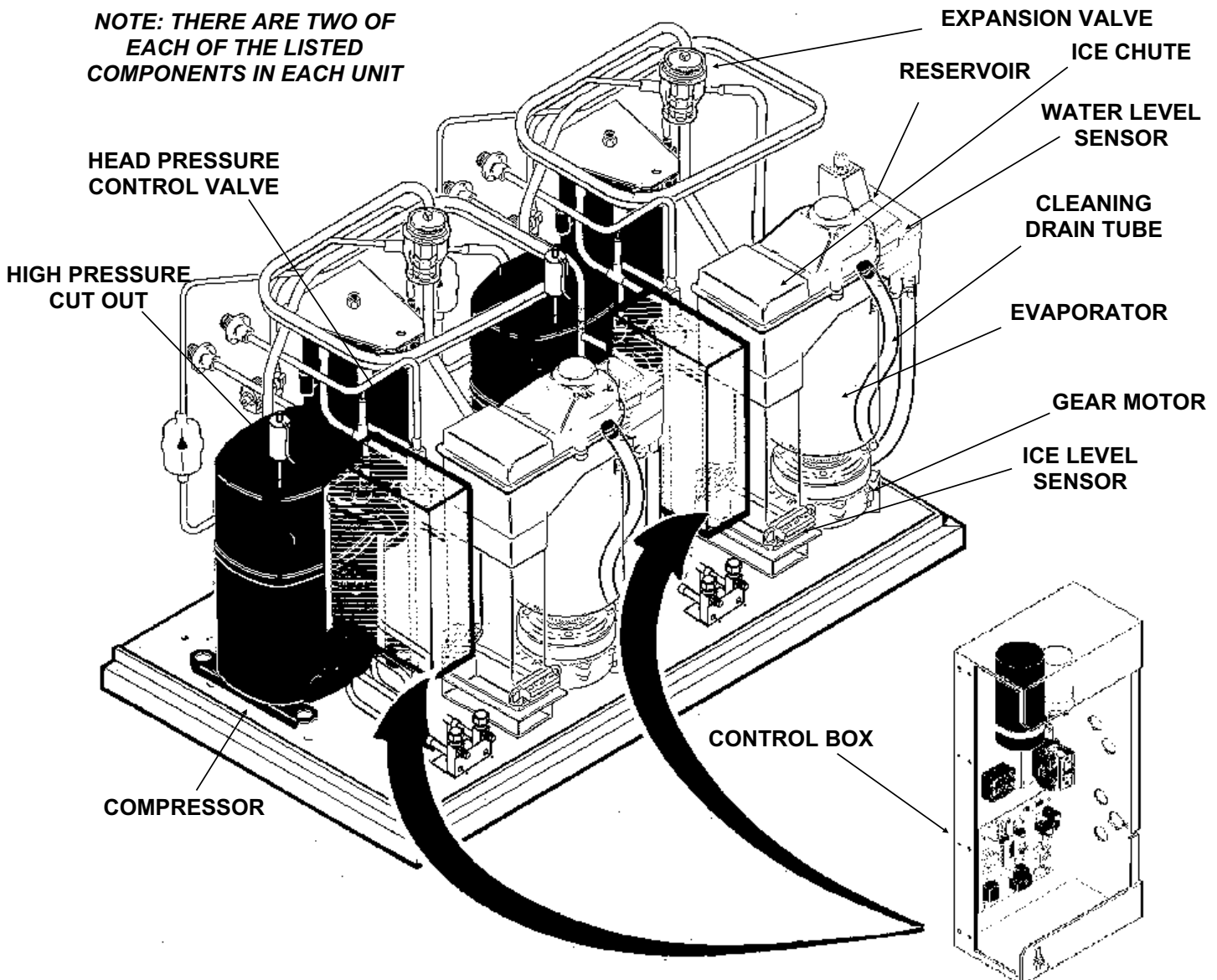

OPERATION: Water

Water enters the machine through the 3/8" male flare at the rear of the cabinet, divides into two inlet lines to each water reservoir which it enters through the float valve. The water then goes out the bottom of the reservoir tanks to the bottom of the evaporators.

Reservoir overflow or evaporator condensation is combined into a common drain line and routed to the drain.

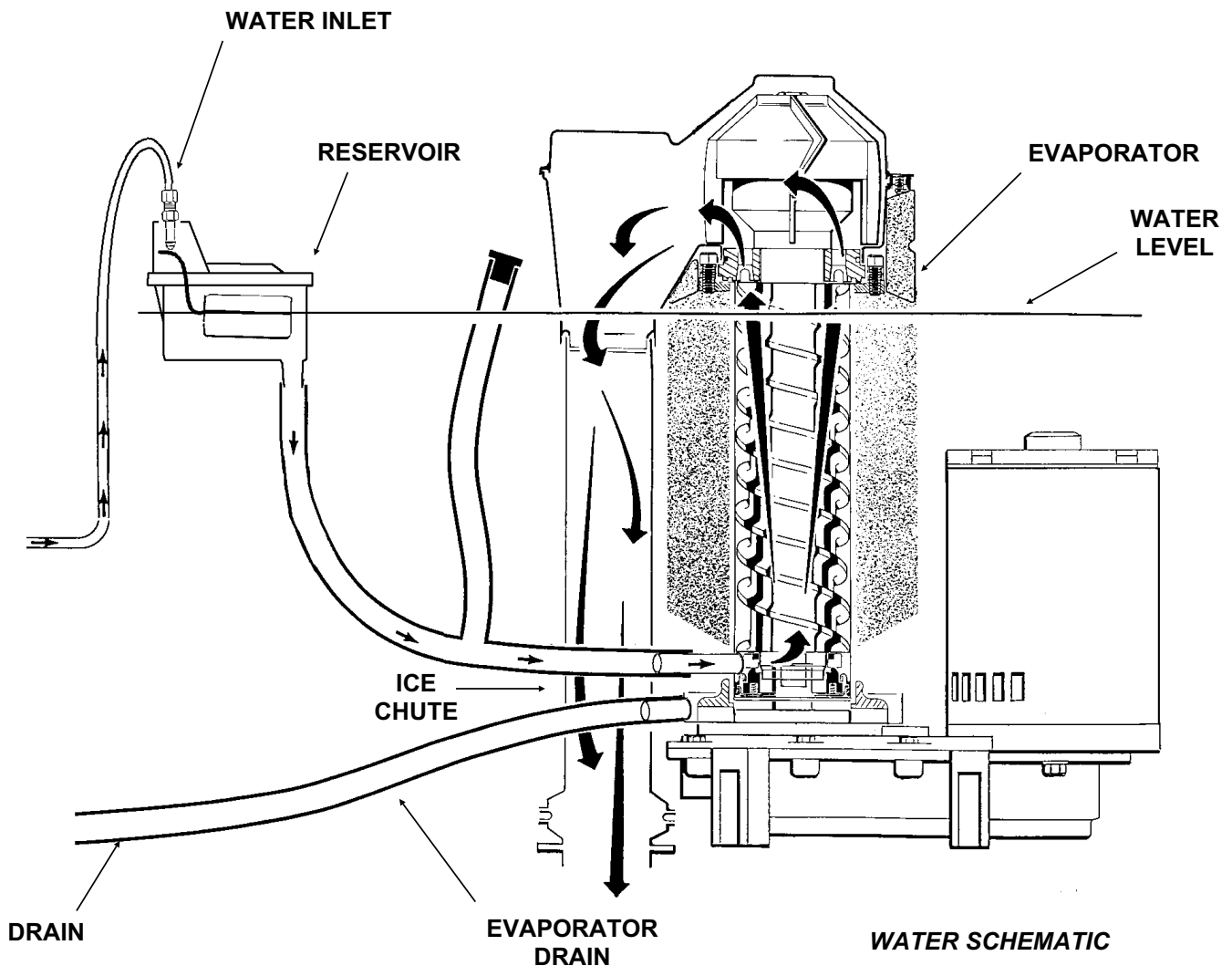

NME1854R & FME2404R

COMPONENT DESCRIPTION: Control Box

There are two control boxes in the machine.

Contactors: A definite purpose contactor connecting the compressor and the remote condenser fan motor to the power supply.

Circuit Board: Controlling the ice machine through sensors and relays. The sensors are for ice level and water level. The relays are for the gear motor (with a built in time delay to clear the evaporator of ice when the unit turns off) and for the liquid line valve.

Potential Relay: The compressor start relay.

On/Off (mode) Switch: Manual control for the machine.

Control Board

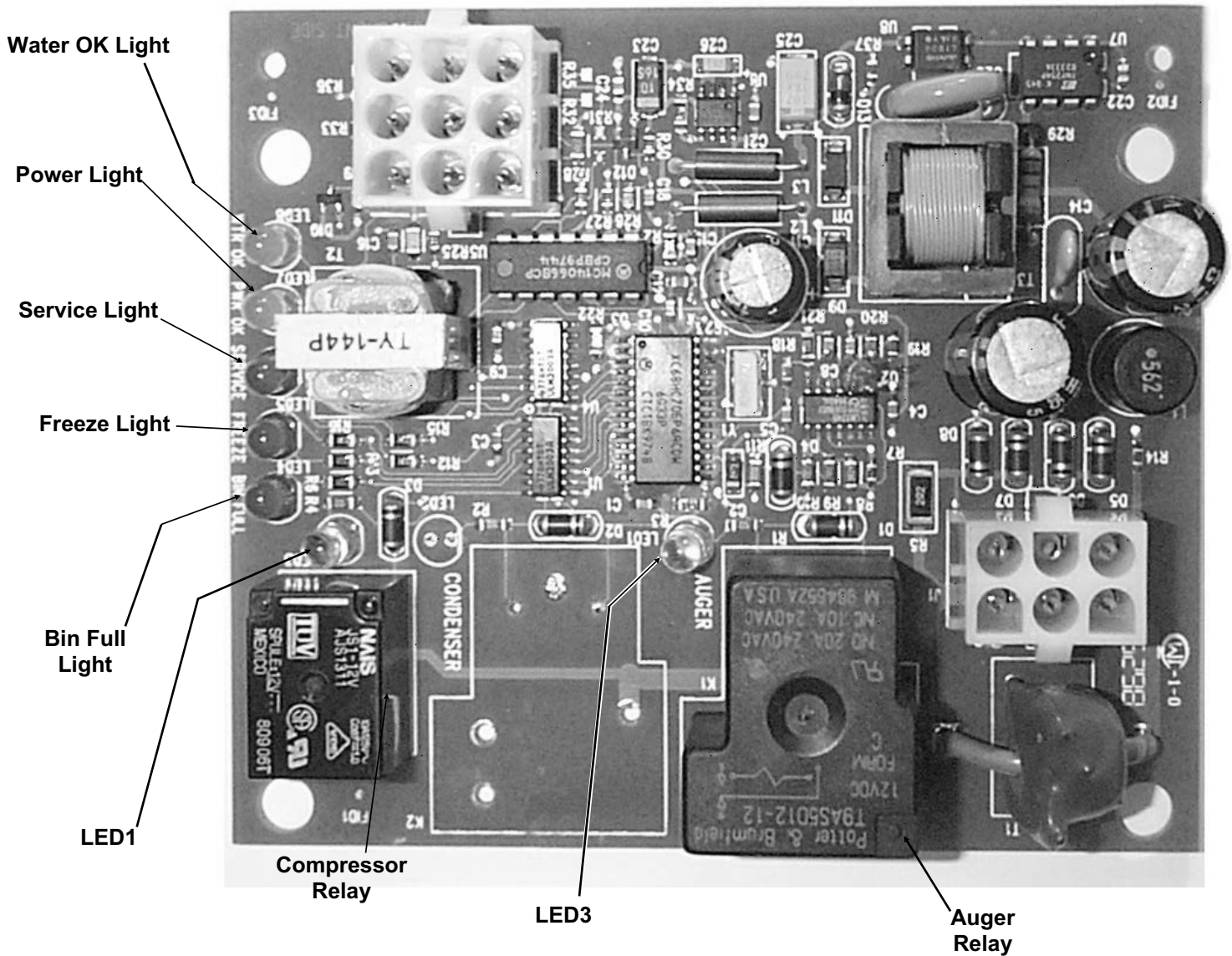

ELECTRICAL SEQUENCE

There are 7 indicator lights on the control board:

- **WTR-OK** (Water OK). *Green. Normal = Glowing. Glows when there is water in the reservoir.*
- **PWR-OK** (Power OK). *Green. Normal = Glowing. Glows when the control board has power and is functional.*
- **Service**. *Red. Normally Off.*
- **Freeze**. *Red. Normally glowing when making ice.*
- **Bin Full**. *Red. Normally Off when making ice.*
- **LED1**. *White. Located next to the board's Compressor Relay. Normally Glowing when making ice.*
- **LED3**. *White. Located next to the board's Auger Motor Relay. Normally Glowing when making ice.*

If the machine is switched off at the mode switch, but is otherwise ready to go, switching the mode switch to ON does the following:

- The PWR-OK light glows.
- If there is water in the reservoir the WTR-OK light glows.
- After 10 seconds the Freeze, LED1 and LED3 lights glow and the machine starts up.

Start Up:

- The compressor relay and auger motor relay become energized, connecting power to the windings of the auger motor and liquid line valve coil.
- The liquid line valve opens, refrigerant flows to the expansion valve.
- The pump down pressure switch closes connecting power to the contactor coil
- The contactor is energized, connecting power to the compressor, and the compressor starts.
- As ice is made it passes between the ice level sensors but because it is not a continuous stream it only interrupts the sensor's infrared beam momentarily. The bin full light remains off and the machine stays on until ice builds up in the bin and blocks the path between the sensors for 6 seconds or longer. When that occurs the bin full light glows and the machine shuts down.

Shut Down:

- The compressor relay opens, LED1 goes out.
- The liquid line valve closes, stopping refrigerant flow.
- The pump down control opens after the suction pressure falls to its cut out point.
- The compressor contactor opens
- The compressor stops
- The auger motor stays on for 1 more minute, clearing out ice in the evaporator, and then
- The auger motor relay opens, LED3 goes out and the auger motor stops.

The liquid line valve will not reopen until 2 minutes or more have passed after the last shut down.

If the path between the ice level sensors remains clear for more than 10 seconds the ice machine will restart.

Control Board Protection Devices

- When the water level in the reservoir falls below the water level sensor's tip, the WTR-OK light goes out and the machine shuts down. When water refills the reservoir the WTR-OK light glows and the machine starts up again.
- If the auger drive motor current becomes excessive the liquid line valve and auger drive motor will be switched Off and the Service light will blink. The control board will restart the auger drive motor in 4 minutes. If during the first 60 seconds after restart the auger motor current stays within limits, the liquid line valve is reopened and the machine returns to normal operation. If the auger motor's current is excessive within 60 seconds after the restart, the process will be repeated once more. If during that try the current is still excessive the machine shuts down and must be manually reset. The service light will then be glowing continuously.

To Reset: Disconnect and reconnect power to the ice machine.

Other Protection Devices:

- If the **high pressure** cut out switch opens the machine will stop immediately. It will automatically reset when the high pressure falls below its cut in point.

The **mode (on - off)** switch is the manual control for the complete machine, but it is not a service disconnect.

NME1854R & FME2404R

SYSTEM INFORMATION

Information @ 90°F. air and 70°F. Water:

Typical Suction Pressure

- 35 PSIG

Typical Discharge Pressure

- 260 PSIG

Minimum Discharge pressure (low temps)

- 180 PSIG

Typical Compressor Amps

- Single Phase = 4.3
- Three Phase = 2.8

Low Pressure (pump down) Control

- Cut in 30
- Cut out 15

High Pressure Cut Out - Automatic Reset

- Cut in 350
- Cut out 450

OPERATION: Refrigeration

There are two separate refrigeration systems in this machine.

At the compressor, refrigerant is compressed into a high temperature gas. The discharge line directs this gas to the condenser. At the remote condenser the gas is cooled by air and it then condenses into a liquid. This high pressure liquid then goes through the liquid line to the head pressure control valve, into the receiver, through the liquid line valve and then through the expansion valve.

The thermostatic expansion valve meters liquid refrigerant into the evaporator, the volume of liquid refrigerant depending upon the temperature of the evaporator; warmer evaporators get more refrigerant and colder evaporators get less.

At the evaporator, the refrigerant enters an area of relatively low pressure, where it can easily "boil off"

or evaporate. As it evaporates, it absorbs heat from the evaporator and whatever is in contact with it (such as the water inside it). After the evaporator, the refrigerant, now a low pressure vapor, goes through the suction line back to compressor, where the cycle is repeated.

Refrigeration Schematic

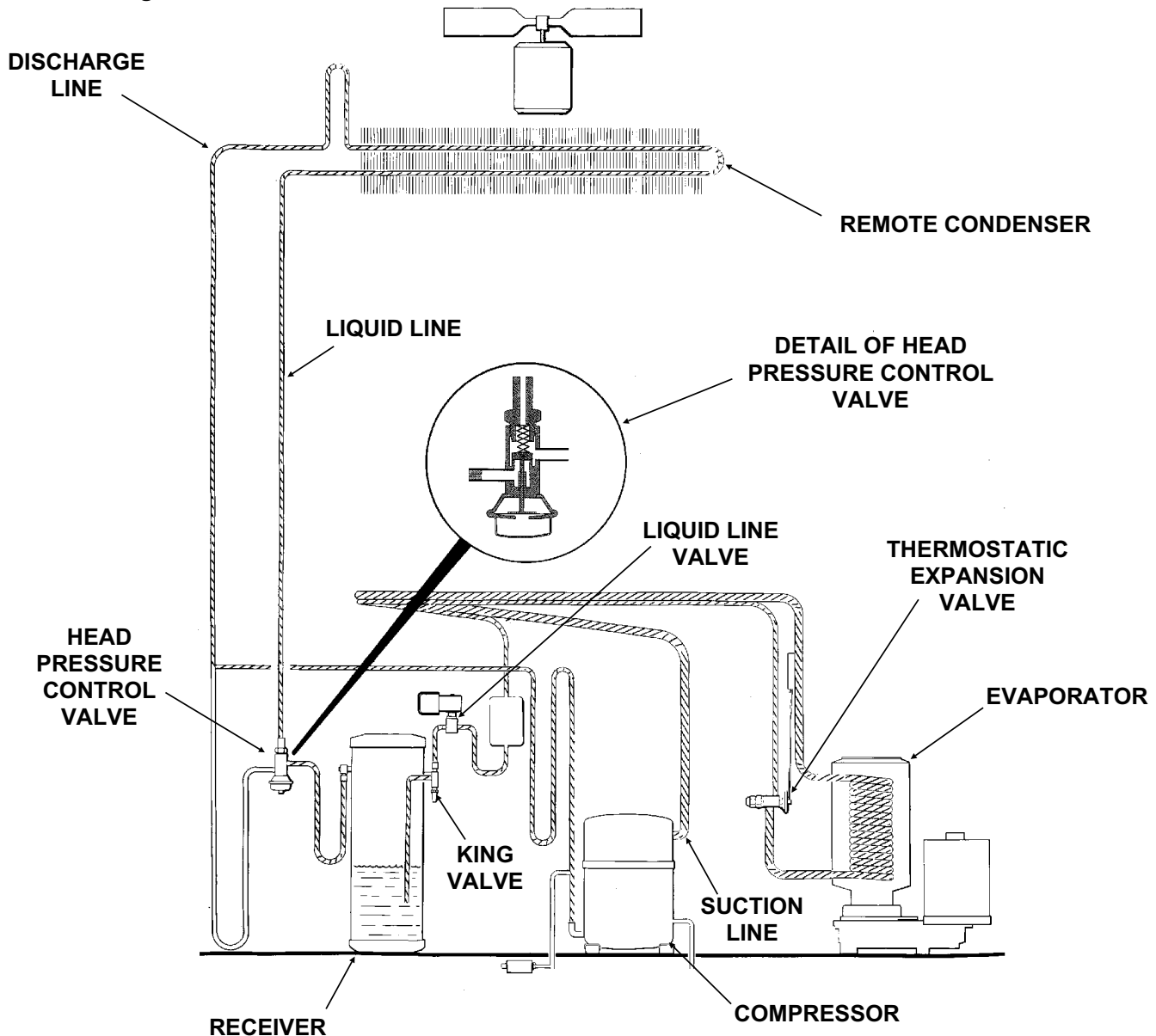

NME1854R & FME2404R

OPERATION: Refrigeration

There are two separate refrigeration systems in this machine.

Low Condensing Temperature

The refrigeration system under low condenser air temperatures is much the same as it is under higher temperatures, with the exception that the resulting low head pressures cause the head pressure control to close off the liquid line between the condenser and the receiver.

This forces more refrigerant into the condenser (with a small amount of discharge gas going into the receiver to maintain pressure until the head pressure is built back up to the rated gauge pressure of 180 psig). At that pressure the valve opens up the liquid line from the condenser to the receiver.

Head Pressure Control Valve - Low Temperature

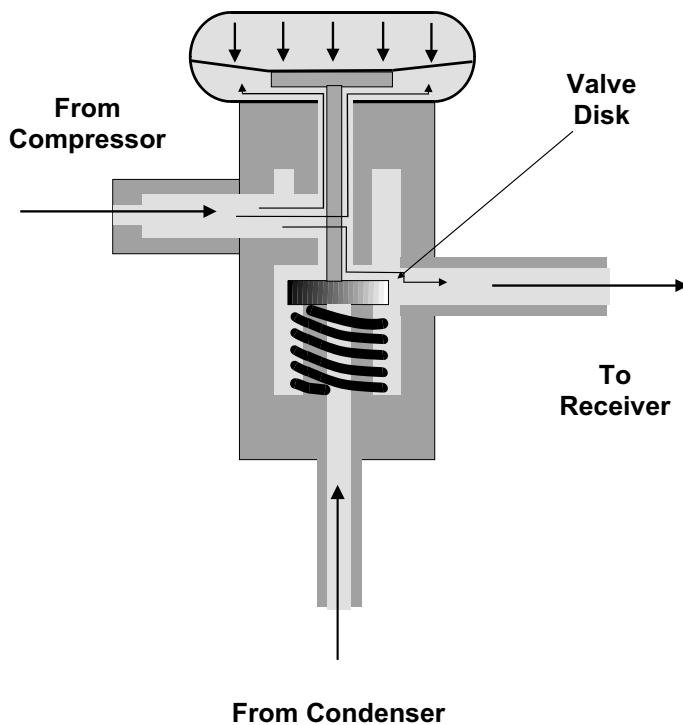

Head Pressure Control Valve - Normal Temperature

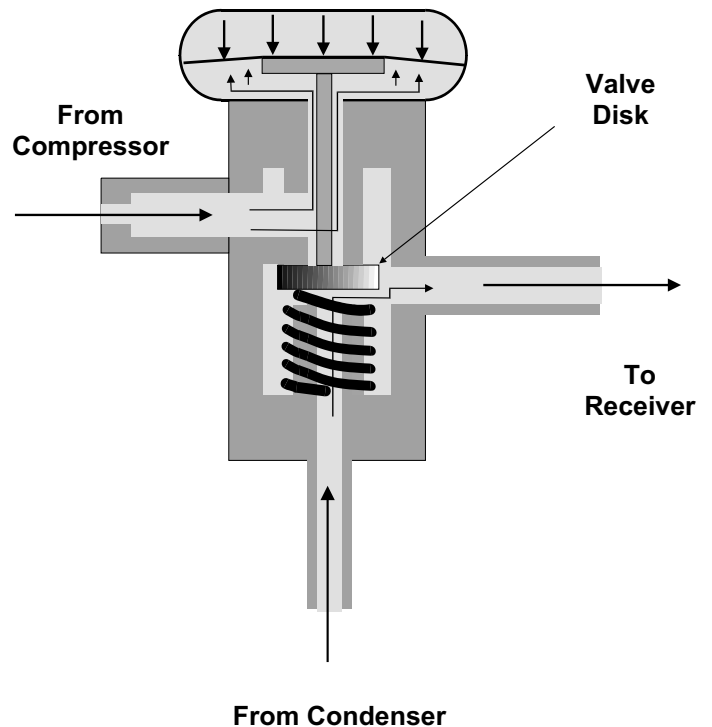

PUMP DOWN

During the pump down cycle (usually initiated by the circuit board de-energizing the liquid line valve) the discharge gases flow through their normal path to the remote condenser, through the head pressure control, and into the receiver.

At this point the refrigerant flow is stopped by the closed liquid line valve. This action forces the refrigerant into the receiver and keeps it out of the compressor. The pump down continues until the low pressure control turns the compressor off.

CLEANING and SANITATION

*These units consist of **two separate** Ice Machines; to properly clean and maintain the them, these steps must be followed for **both** systems.*

A Scotsman Ice System represents a sizable investment of time and money in any company's business. In order to receive the best return for that investment, it MUST receive periodic maintenance.

It is the USER'S RESPONSIBILITY to see that the unit is properly maintained. It is always preferable, and less costly in the long run, to avoid possible down time by keeping it clean; adjusting it as needed; and by replacing worn parts before they can cause failure. The following is a list of recommended maintenance that will help keep the machine running with a minimum of problems.

Maintenance and Cleaning should be scheduled at a minimum of twice per year.

ICE MAKING SYSTEM: In place cleaning

1. Check and clean any water treatment devices, if any are installed.
2. Remove screws and the front panel.
3. Move the ON-OFF switch to OFF.
4. Remove all the ice from the storage bin.
5. Remove the cover to the water reservoir and block the float up.
6. Drain the water reservoir and freezer assembly using the drain tube attached to the freezer water inlet. Return the drain tube to its normal upright position and replace the end cap.
7. Prepare the cleaning solution: Mix eight ounces of Scotsman Ice Machine Cleaner with three quarts of hot water. The solution should be between 90 and 115 degrees F.

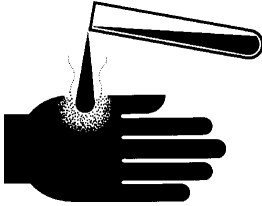
⚠ WARNING	Scotsman Ice Machine Cleaner contains acids. These compounds may cause burns.
	If swallowed, DO NOT induce vomiting. Give large amounts of water or milk. Call Physician immediately. In case of external contact, flush with water. Keep out of the reach of children.

8. Slowly pour the cleaning solution into the water reservoir until it is full. Wait 15 minutes, then switch the master switch to ON.
9. As the Ice Machine begins to use water from the reservoir, continue to add more cleaning solution to maintain a full reservoir.
10. After all of the cleaning solution has been added to the reservoir, and the reservoir is nearly empty, switch the master switch to OFF.
11. After draining the reservoir, as in step 6, wash and rinse the water reservoir.

12. Go thru steps 13-19 to sanitize the ice machine water system.

13. Mix two gallons of sanitizer solution. Use an approved sanitizer.

A possible sanitizer solution may be obtained by mixing two gallons of warm (90-115oF.) potable water with 1 ounce of household bleach.

14. Slowly pout the sanitizer solution into the water reservoir until the float rises, then switch the master switch ON.

15. As the ice machine uses water from the reservoir, continue to pour the sanitizer solution into the reservoir.

16. After ½ of the sanitizer solution has been added to the reservoir, and the reservoir is nearly empty, switch the master switch OFF.

17. Drain the reservoir and thoroughly wash the interior of the reservoir and cover with sanitizer solution. Be sure the drain hose is upright and capped.

18. Remove the block from the float in the water reservoir.

19. Switch the master switch to ON

20. Continue ice making for at least 15 minutes, to flush out any cleaning solution.

DO NOT USE any ice produced from the cleaning solution. Be sure no ice remains in the bin.

21. Remove all ice from the storage bin.

22. Add warm water to the ice storage bin and thoroughly wash and rinse all surfaces within the bin.

23. Sanitize the bin interior by washing the interior of the bin with the balance of the sanitizer solution.

24. Switch the master switch ON.

NME1854R & FME2404R

SENSOR MAINTENANCE

*These units consist of **two separate** Ice Machines; to properly clean and maintain the them, these steps must be followed for **both** systems.*

1. The bin control uses devices that sense light, therefore they must be kept clean enough so that they can "see". At least twice a year, remove the bin control sensors from the base of the ice chute, and wipe the inside clean, as illustrated.

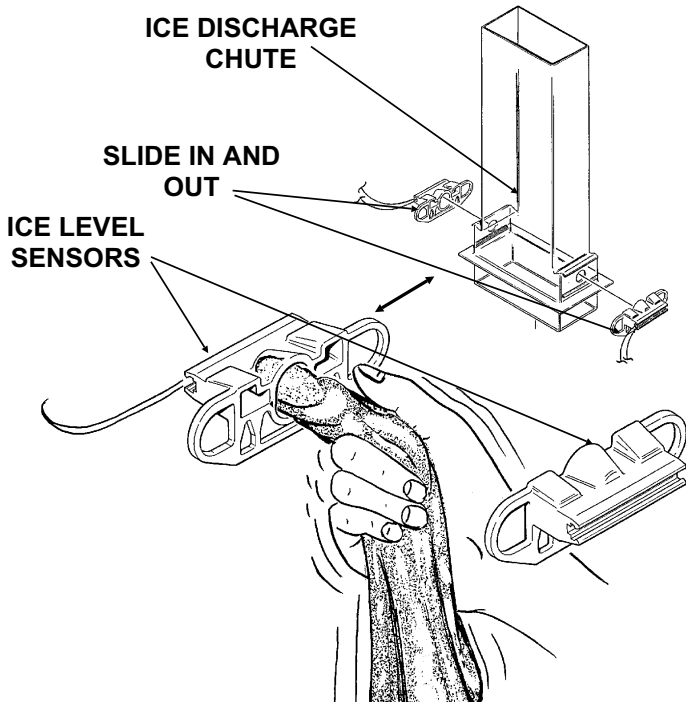

2. The ice machine senses water level by a probe located in the water reservoir. At least twice a year, the probe should be removed from the reservoir, and the tip wiped clean of mineral build-up.

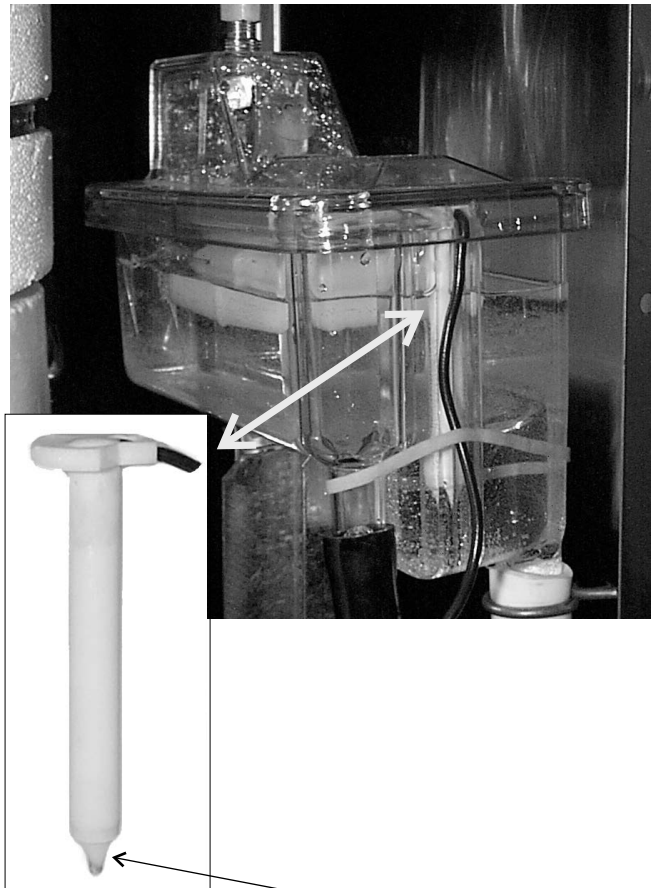

Clean the Probe's Tip with ice machine cleaner and a clean, soft cloth.

3. Clean the air cooled remote condenser coil when it becomes restricted.

BEARING MAINTENANCE

The top bearing in the breaker should also be checked at least **two times per year**.

Check the breaker bearing by:

- removing the ice chute cover

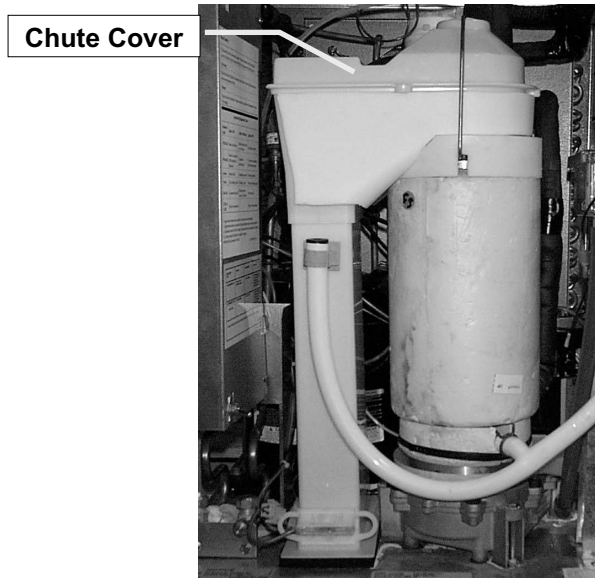

- unscrewing the ice sweep

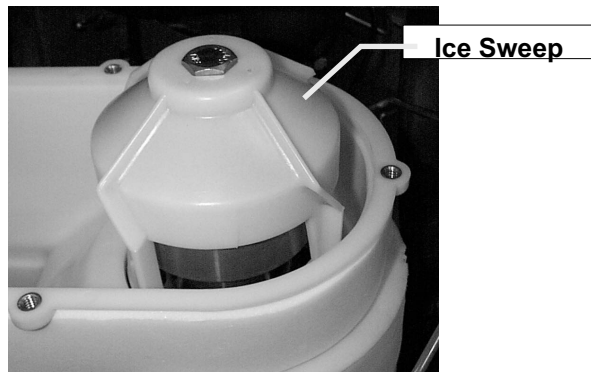

- removing the water shed and the breaker cover (left hand thread)

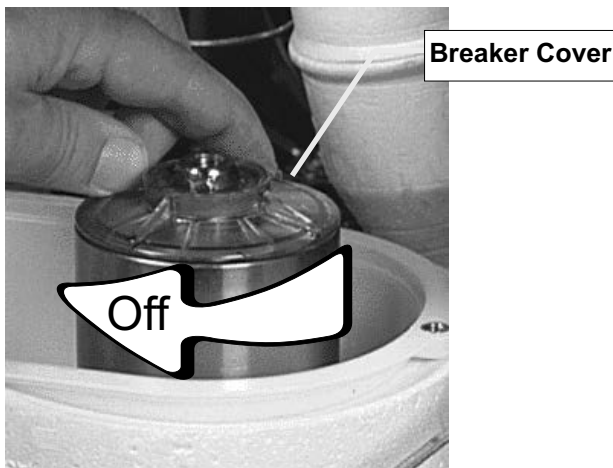

- unscrewing the auger stud

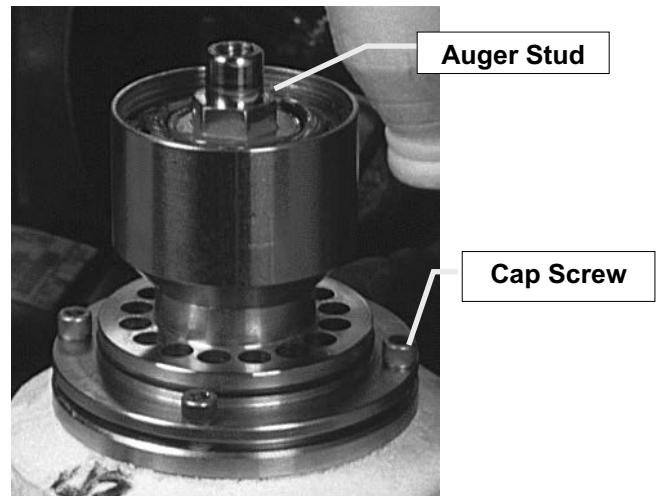

Inspect the bearing. There should be plenty of grease in sight. If grease is needed the bearing and breaker should be removed to check the action of the bearing. It should rotate smoothly.

To remove the breaker take out all four allen head cap screws and pull the breaker off the auger and evaporator.

If the bearing only needs grease, inject grease into the bearing using Scotsman grease needle pn 02-3559-01 and Scotsman bearing grease cartridge, pn A36808-001. Be sure to inject grease evenly and thoroughly.

See Removal and Replacement section to replace bearing or seals.



Reverse to reassemble.

NME1854R & FME2404R

AUGER MAINTENANCE

In some areas the water supply to the Ice Machine will have a great deal of minerals in it, and that will result in an evaporator and auger becoming coated with these minerals, requiring a more frequent removal than twice per year. If in doubt about the condition of the evaporator and auger, the auger can be removed so the parts can be inspected.

Note: Water filters can filter out suspended solids, but not dissolved solids. "Soft" water may not be the complete answer. Check with a water treatment specialist regarding water treatment

For more information on removal and replacement of these parts, see REMOVAL AND REPLACEMENT.

Shut off water and electrical supply.

1. To remove the auger, remove the front and top panels.
2. Push back bail clamp holding ice chute cover to ice chute, and remove cover.
3. Unscrew and remove ice sweep.

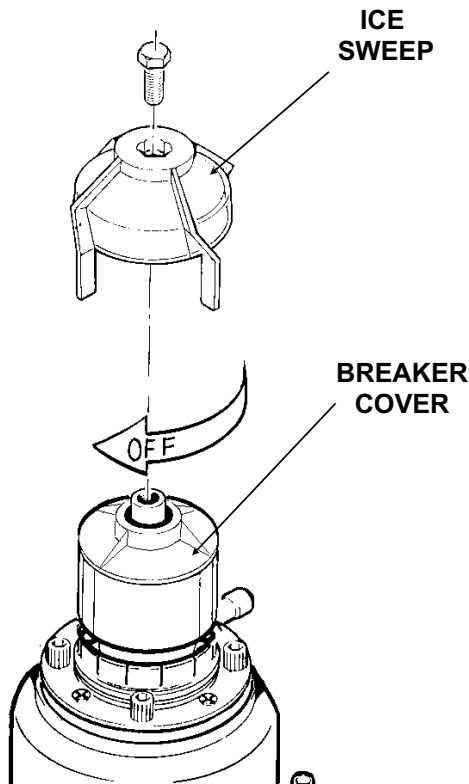

4. Remove ice chute from evaporator.
5. Remove 4 allen screws holding breaker to evaporator.

6. Pull up to remove auger.

After the auger has been removed, allow the auger to dry; if the auger is not bright and shiny, it must be cleaned.

Clean the auger and evaporator as required.

DO NOT HONE THE EVAPORATOR.

7. Replace the water seal.
8. Reverse to reassemble.

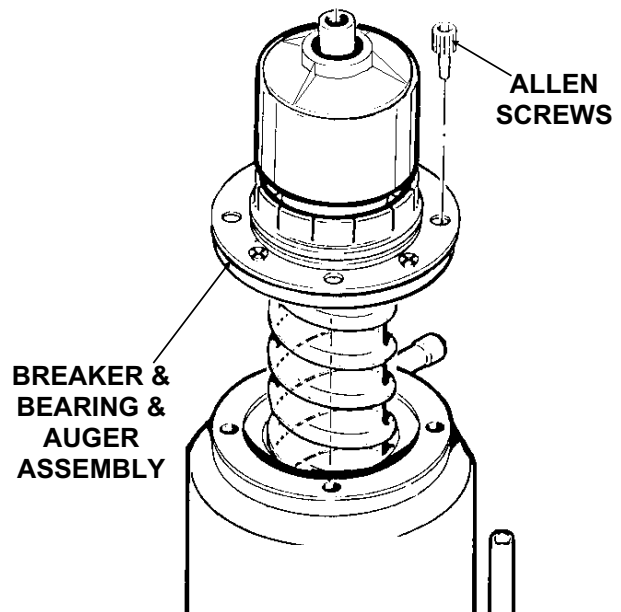

NME1854R & FME2404R

SERVICE DIAGNOSIS: Condition

Symptom	Possible Cause	Probable Correction
No ice is made, nothing operates	Unit off due to no power.	Restore power
	Unit off due to master switch in Off position	Move master switch to ON
	Unit off due to low water level in reservoir	Check water supply, filter and float valve.
	Unit off due to ice level sensors (photo-electric eyes) blocked	Check/clean ice level sensors
	Unit off due to scale on water level sensor	Clean water level sensor
	Unit off due to high pressure control open	Check for remote condenser fan motor failure or power interruption to the fan motor
	Auger motor hums but does not turn	Auger can't turn. Circuit board has not yet shut unit down.
	Unit is shut down	Circuit board has shut ice machine down due to high auger motor amp draw. Check for cause of high amp draw, including bearings, gear motor condition and scale on auger & evaporator.
	Pump down pressure control open, very low suction pressure	Auger not turning due to: motor failure; auger relay failure on circuit board; or gears stripped. Check drive train.
		Liquid line valve not opening due to coil failure or failure of compressor relay on circuit board
		TXV restricted or not metering. Check bulb temperature.
		Lack of refrigerant. Check for a leak.
	No power to circuit board	Check harness
		Hi or Low pressure switches open
Circuit board gear motor relay open	Check / replace board	
Water level or ice level sensor failed	Check / replace sensor	
No ice, auger motor is turning	Compressor contactor coil is open	Check / replace contactor
	Compressor will not start	Check start capacitor
		Check start relay
		Check compressor windings
	Circuit board relay will not close	Check / replace board
Pump down pressure switch does not close, liquid line valve open and suction pressure high	Check pump down switch contacts	

NME1854R & FME2404R

SERVICE DIAGNOSIS:

Symptom	Possible Cause	Probable Correction
Unit makes ice, but very slowly	High discharge pressure because of a dirty condenser coil	Clean the condenser
	Auger and evaporator are coated with mineral scale	Clean the water system
	Low refrigerant charge	Locate leak. Recover refrigerant, repair leak, replace dryer, evacuate and weigh in the nameplate charge.
Water leak	Ice storage bin drain restricted	Clean out drain
	Tubing cracked	Replace tubing
	Condensation on drain tubing	Insulate tubing
	Hose off	Re-attach hose
	Reservoir cover off	Return cover to reservoir
	Reservoir cracked	Replace reservoir
	Evaporator water seal leaks	Check base of evaporator & drip pan. If the seal leaks, shut off the water, remove the auger, replace the water seal. Check gear motor for water infiltration.
Excessive ice meltage	Bin drain clogged	Clean out bin drain
	Poor fit between bin door and door frame	Adjust or replace
Machine makes too much noise	Evaporator coated internally with minerals	Clean with Scotsman Ice Machine Cleaner
	Motor bearings dry	Oil or replace motor

CONTROL SYSTEM DIAGNOSTICS

The control system consists of:

- Control Board
- Water Sensor
- Ice Sensors
- High Pressure Cut Out
- Low Pressure Cut Out

If the unit is OFF, check the **control board**:

1. Is the Power OK light on? If not check power to the unit. If it has power, and the Power OK light is NOT on, check the high pressure and low pressure cut outs. If they are both closed, replace the board. If the Power OK light is ON, go to the next step.

2. Is the Water OK light on? If it is, go to the next step. If not, check the water level in the reservoir. If there is water in the reservoir, check that the water sensor is plugged in. To check the **water sensor**:

A. Unplug water sensor.

B. Pull water sensor from reservoir.

C. Place one ohmmeter lead on the sensor's plug and the other on the sensor's tip. The meter should show nearly zero resistance. If it reads infinite resistance, check the tip for corrosion. If it is clean and still reads open, replace the sensor.

OR connect a copper wire to the wire where the water sensor plugs into and place the other end in the water. The water OK light should go ON. If it does not, replace the control board.

3. **Ice sensor check.** Is the Bin Full light Off? If it is OFF and the Service light is Off, and the unit is not running, replace the control board.

If it is OFF and the auger motor is running but the compressor is not, check the compressor contactor coil.

If it is on, the ice sensors may be blocked. Remove them and check for mineral scale. Scotsman's test box can also be used to determine if the ice sensors or board are defective.

Using the tester:

A. Disconnect the ice sensors at the connection by the ice chute. Connect the LED and PHOTO TRANS wires to the control board's wires.

B. With the On - Off (mode) switch in either position, move the Bin Full switch on the tester to Bin Full - the tester's light will blink and after a few seconds the bin full light on the control board will come on. If not, replace the board.

Move the Bin switch on the tester to Bin Empty. The light on the tester will go out, and after a few seconds the Bin Full light on the board will go out. If master switch is ON, the unit should start.

4. **High pressure** cut out check.

Disconnect electrical power.

Pull the wires off the high pressure cut out.

Use an ohmmeter to determine if the switch is OPEN, If it is, check the discharge pressure. If the discharge pressure is less than 300 PSIG, replace the high pressure cut out.

If the high pressure cut out is open and the system has high discharge pressure, check for the cause.

5. **Low pressure** cut out check.

Disconnect electrical power.

Pull the wires off the low pressure cut out.

Use an ohmmeter to determine if the switch is OPEN, If it is, check the suction pressure. If the suction pressure is greater than 20 PSIG, replace the low pressure cut out.

If the low pressure cut out is open and the system has low suction pressure, check for the cause.

NME1854R & FME2404R

REMOVAL AND REPLACEMENT: Water Reservoir & Bin Controls

WATER RESERVOIR

1. Shut off the water supply to the Ice Machine.
 2. Remove front panel and reservoir cover.
 3. Disconnect water inlet tube from reservoir inlet fitting.
 4. To remove float valve, push in "locking tabs" as shown and pull float up.
- Note: The plunger/seat is available separately as a part.
5. To remove reservoir, pull up and remove water sensor.
 8. Disconnect water outlet tubes.
 9. Remove mounting screws from reservoir bracket and remove the reservoir from the Ice Machine.
 10. Reverse to reassemble.

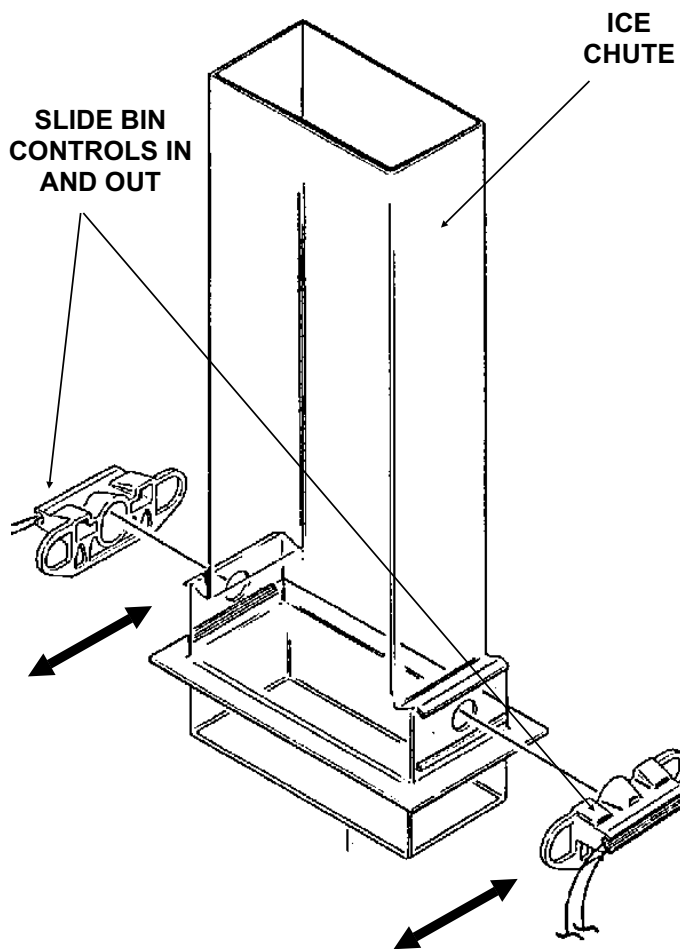
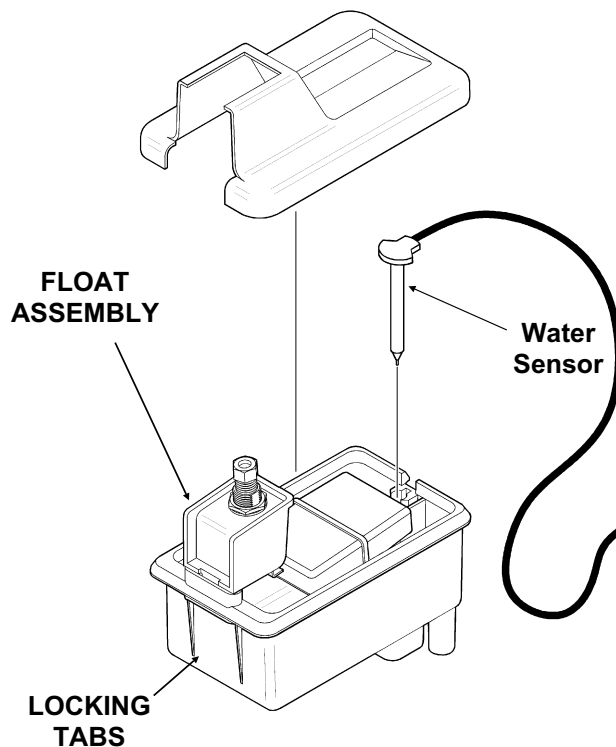

BIN CONTROLS (Ice Level Sensors)

1. Disconnect electrical power.
2. Remove front panel.
3. Remove control box cover.
4. Locate ice chute, at the base of the chute, in front of and behind it are two plastic bin control mounts.
5. Slide each bin control to the left, and in the control box, disconnect the electrical leads connecting the bin control to the circuit board.
6. Reverse to reassemble, be certain that the bin controls are aligned so that the ice level sensors are visible (centered) through the holes in the ice chute.

NME1854R & FME2404R

REMOVAL AND REPLACEMENT: Bearing And Breaker

Note: Removal of the auger, water seal, evaporator and gear motor must begin at the top of the assembly.

To Remove the Breaker Bearing Assembly:

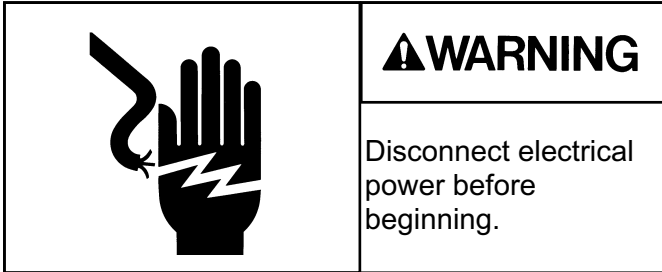

1. Remove panels and disconnect electrical power.
2. Push back bail clamp and remove ice chute cover.
3. Unscrew and remove ice sweep.
4. Lift up and remove ice chute.
5. The breaker may be removed from the auger and evaporator without disturbing the auger.
 - a. Unscrew breaker cover from breaker (left hand threads)
 - b. Unscrew auger stud from top of auger.
 - c. Unscrew 4 allen head cap screws holding breaker to evaporator.

d. Lift up, and remove breaker/bearing assembly from auger & evaporator.

6. Service the bearing. Check for rust, rough spots and damage.

a. The bearing is pressed into the breaker, to remove the bearing and replace it an arbor press is needed.

b. Replace lower seals before installing new bearing in breaker.

Note: seals must be pressed in with a tool pushing against the outer edge only, they will not install by hand.

Replace parts as required. Re-grease bearing with Scotsman part no. A36808-001 bearing grease. Replace top seal, and check the o-rings, replace if cut or torn.

7. Reverse to reassemble: specific tools and materials are required to install properly.

a. Add food grade grease such as Scotsman part number 19-0569-01 to the seal area before installing on the auger.

b. Check the seal to shaft areas for cuts, or rough spots: none are permitted.

Note: Flaker parts are shown in this manual. Nugget (NME) breakers do not have a Slotted Collar.

Step 5-a

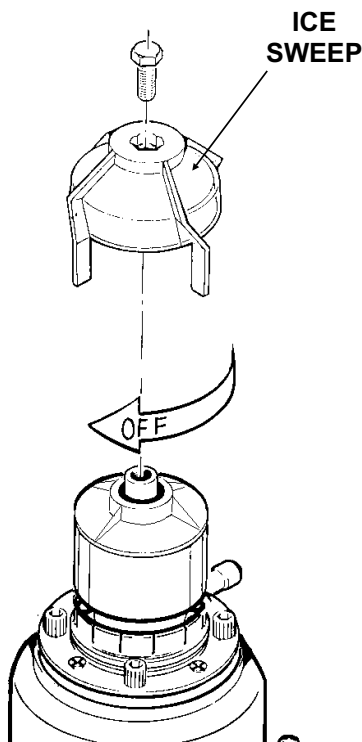

Step 5-b

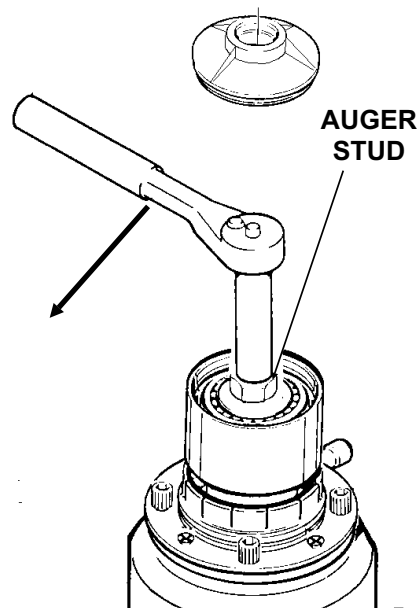

Step 5-c and Step 6

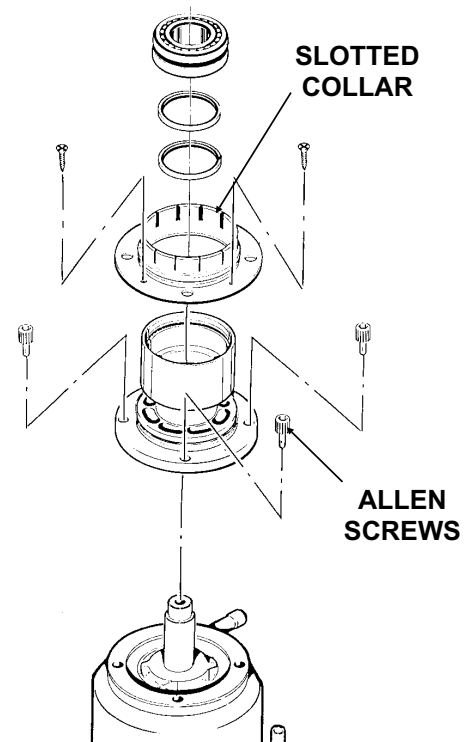

NME1854R & FME2404R

REMOVAL AND REPLACEMENT: Auger

Note that the auger has very sharp edges.

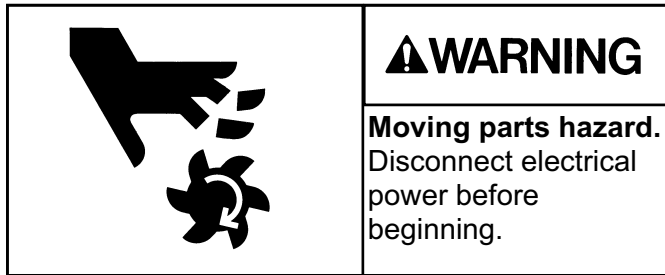

To Remove the Auger:

Turn off the water to the machine, and unclip the evaporator drain hose, pull it down and drain the evaporator into the bin or a container.

1. Remove the top panel.
2. The auger and breaker/bearing may now be removed as an assembly.
 - a. Unscrew 4 allen head cap screws holding breaker to evaporator.
 - b. Lift up on breaker and remove auger from evaporator.

Note: If the auger is stuck, the breaker must be removed from the auger.

The breaker may be removed from the auger and evaporator without disturbing the auger.

- a. Unscrew breaker cover from breaker (left hand threads)
- b. Unscrew auger stud from top of auger.
- c. Unscrew 4 allen head cap screws holding breaker to evaporator.
- d. Lift up on breaker to remove from auger.

If the auger is stuck:

Use a slide hammer type puller to pull on the auger at the threaded hole. The size of that hole is 5/8"-18.

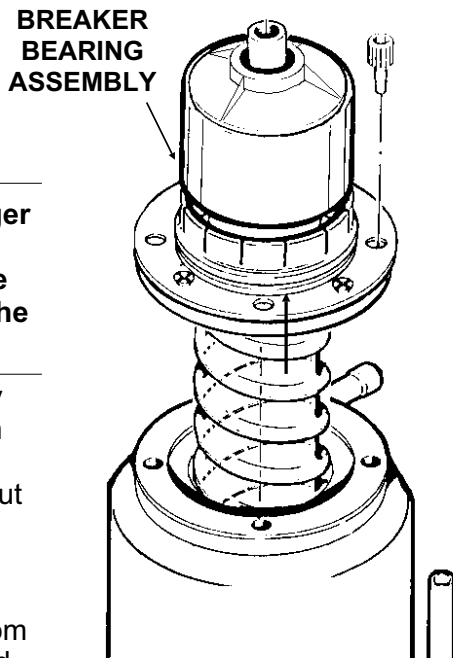

Inspect the auger, the critical areas of the auger are:

- a. The auger body. It should be clean and shining. Sometimes an auger will appear clean when wet, but after it is dry it will be seen to be stained. Scrub the auger with ice machine cleaner and hot water.

WARNING

Ice machine cleaner is an acid. Handle it with extreme care, keep out of reach of children.

- b. The water seal area. Because the auger has been removed, the water seal will have to be replaced. Remove the water seal top half from the auger, and inspect the auger for minerals clean as required.

Note: Repeat the above for each evaporator.

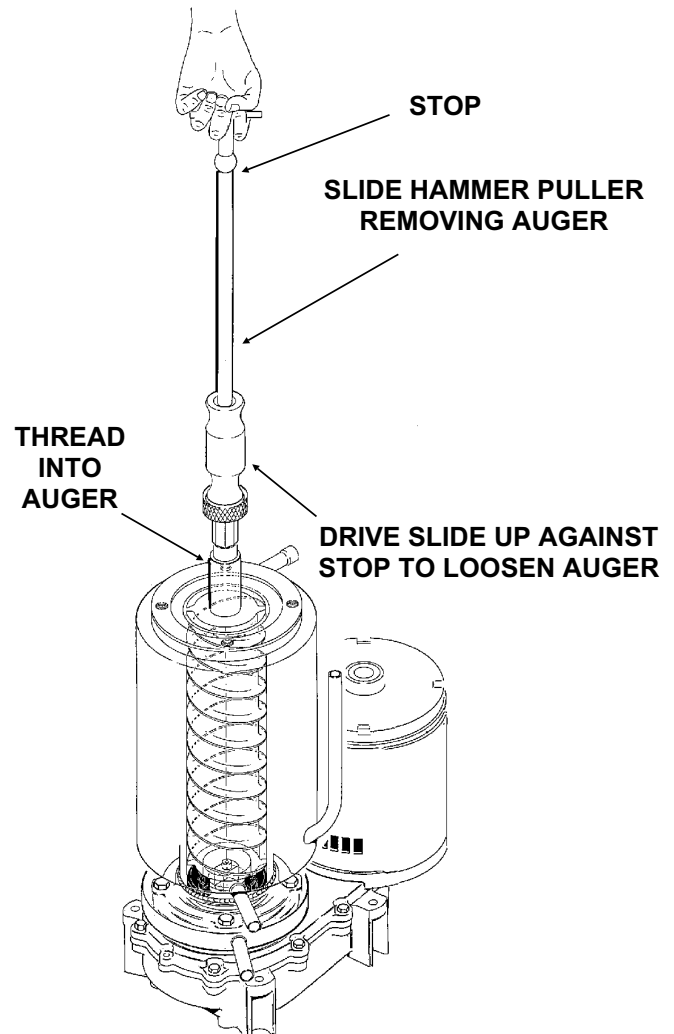

REMOVAL AND REPLACEMENT: Water Seal

To Remove the Water Seal:

(Assuming all steps to remove the auger have been performed.)

1. The gear motor/evaporator assembly will have to be exposed (if not yet done).
2. Remove the 4 hex head cap screws holding the evaporator to the gear motor assembly. Lift the evaporator up and off of the gear motor.
3. Remove the snap ring or wire retainer from the groove under the water seal.
4. Pull or drive out the lower half of the water seal.

To Replace the Water Seal:

1. Lubricate the water seal with water, and push the water seal into the bottom of the evaporator slightly past the groove for the snap ring.
2. Replace the snap ring and pull the water seal down against it.
3. The part of the water seal that rotates with the auger must also be replaced. Remove the old part from the auger and clean the mounting area.
4. Place a small bead of food grade silastic sealant (such as 732 RTV or Scotsman part number 19-0529-01) on the area of the auger where the water seal is to be mounted.
5. Carefully push the water seal (rubber side against the auger shoulder and the silastic.)

CAUTION

Do not get any silastic onto the face of the seal.

6. Allow the auger and seal to air dry until the silastic is dry on the surface.
7. If the original water seal was leaking, it would be a good idea to inspect the interior of the gear motor.

REMOVAL OF THE WATER SEAL

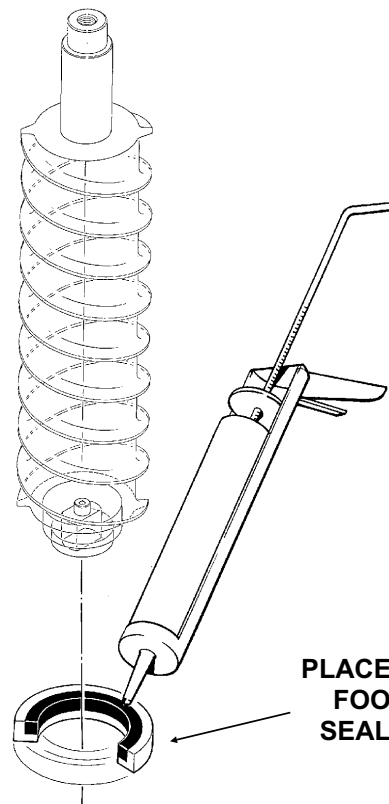
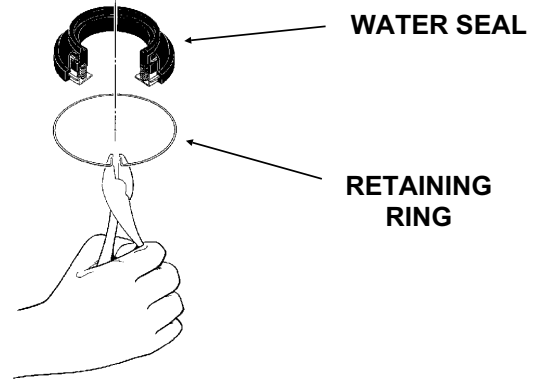
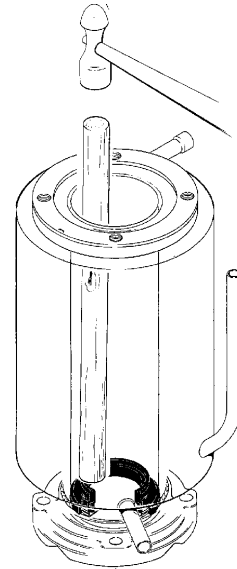

PLACE A BEAD OF FOOD GRADE SEALANT HERE

NME1854R & FME2404R

REMOVAL AND REPLACEMENT: Evaporator

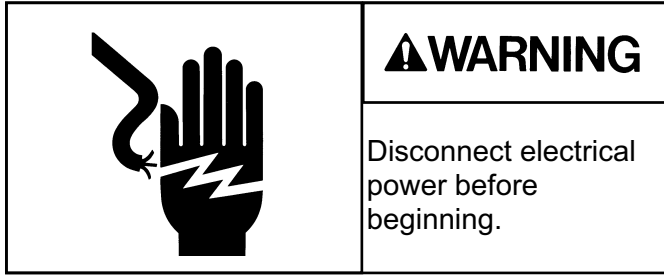

Shut off the water supply before beginning.

To Replace the Evaporator:

(Assuming all the steps for removal of the thrust bearing, breaker, auger, and water seal have been performed.)

1. Discharge the refrigerant from the Ice Machine.
2. Unsweat the refrigerant connections:
 - a) At the thermostatic expansion valve outlet.

CAUTION

Heat sink the TXV body when unsweating or resweating the adjacent tubing.

- b) At the suction line at the joint about 3" from the evaporator.
3. Disconnect the water inlet tube, and remove the evaporator.
 4. Unsweat the drier from the liquid line.

Repeat the above, as required, for each system.

5. After installing a new water seal in the new evaporator (see "To Replace the Water Seal") resweat the tubing connections.
6. Install an new drier in the liquid line.
7. Evacuate the system until dehydrated, then weigh in the nameplate charge. Check for leaks.
8. Install auger, breaker, breaker bearing assembly, and ice discharge chute in reverse order of disassembly. See "To Reassemble Evaporator and Auger"

To Reassemble the Evaporator and Auger

1. After the gear motor has been inspected, fasten the evaporator to the gear motor, be sure that the number of shims indicated on the gear case cover is in place between the gearcase cover and the drip pan gasket. Torque the bolts to 110 inch pounds.
2. Lower the auger into the evaporator barrel, slightly turning it to match up with the drive end. Do Not Drop Into the Evaporator.
3. Complete the reassembly by reversing the disassembly for the breaker & thrust bearing assembly.

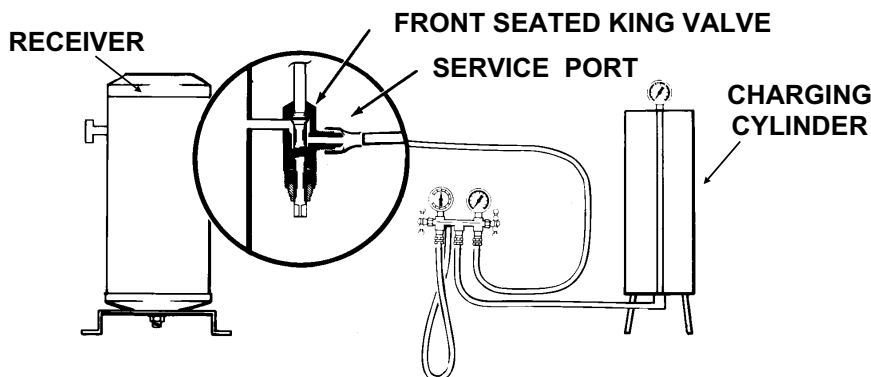

Charging Procedures

Extra care must be taken when recharging this remote system. No liquid refrigerant may be placed in the system at the compressor. DO NOT use the access valves at the front of the unit for weighing in the charge. All liquid R-404A must be weighed into the receiver through the "front seated" king valve.

REMOVAL AND REPLACEMENT: Gear motor Assembly

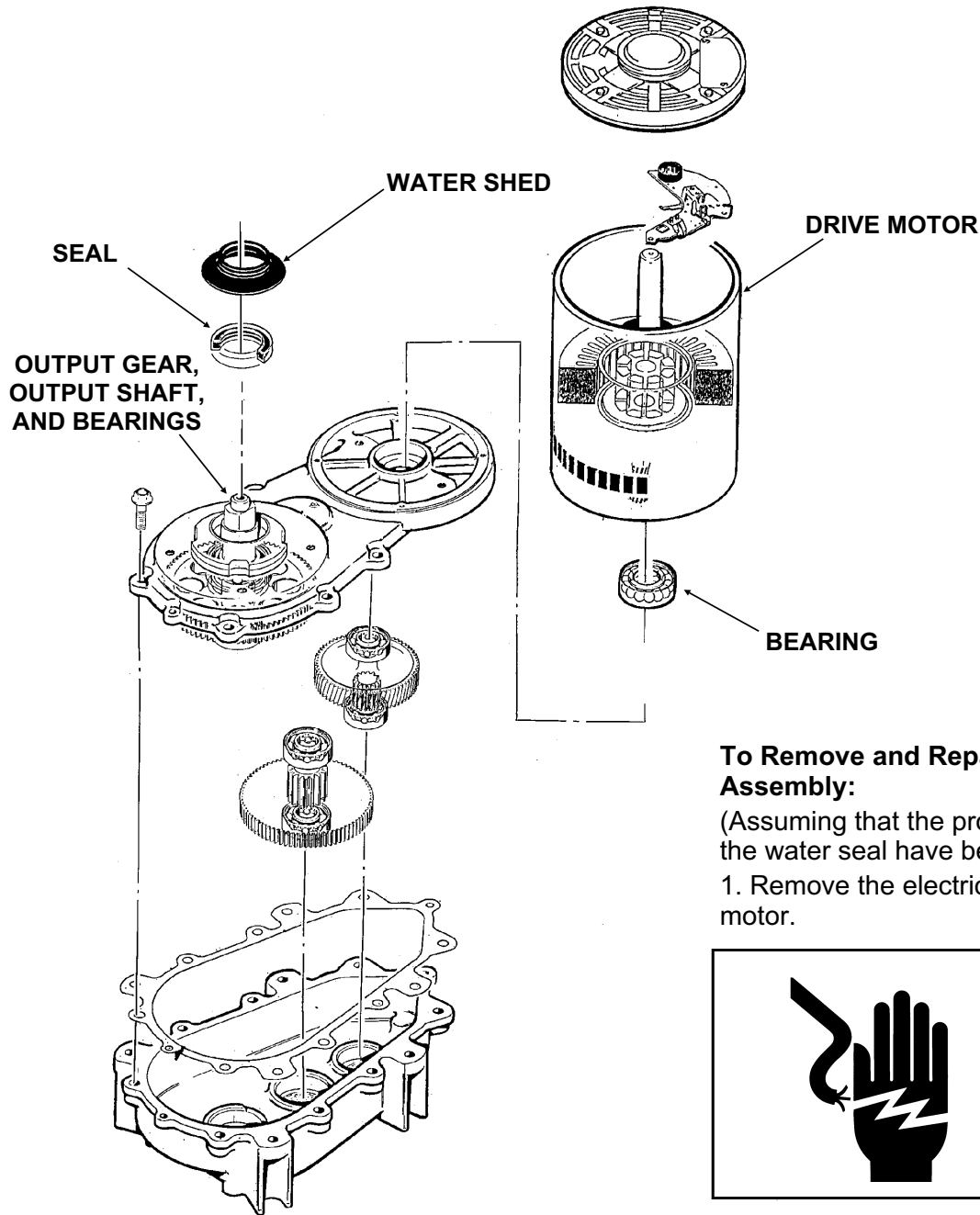

To Remove and Repair the Gear motor Assembly:

(Assuming that the procedures through removal of the water seal have been performed.)

1. Remove the electrical wires from the gear drive motor.

	⚠ WARNING
	Disconnect electrical power before beginning.

Note: There are two gear motors in each unit.

2. Unscrew the 4 cap screws holding the gear motor to the gear motor plate.
3. Remove the gear motor from the Ice Machine.

To Inspect the gear motor.

A) Remove the cap screws holding the gear motor case halves together and pry the two cases apart.

B) To lift off the cover, lift up until you can feel internal contact, then pull the cover towards the output gear end, and then lift the cover (with drive motor attached) up and away from the gear motor case.

Note: The case cover output gear, bearings, and shaft are one pressed together assembly.

NME1854R & FME2404R

REFRIGERATION SYSTEM SERVICE

General: This ice machine uses R-404A refrigerant and polyolester oil. Do NOT use mineral oil in this refrigeration system.

- When the system is serviced, a special liquid line drier is required. It is included with replacement compressors.
- R-404A is not compatible with mineral oil so these ice machines use Polyolester oil. Polyolester oil absorbs water very easily. A system opened for service must be re-sealed as soon as possible (15 minutes maximum).
- Special leak detection equipment is required to locate small refrigerant leaks. Usually a leak detector capable of detecting a Halogenated refrigerant or HFC-134a will work. Check with the leak detector manufacturer if in doubt.
- Evacuate to 300 microns.
- Liquid charge the system

Access Valves: To use the access valves:

- Remove the cap from the stem, use a 3/16" allen wrench to check that the valve is CLOSED. Then remove the core cap.
- Close the valve and replace the caps when done. The valve must be closed and the caps must be on or the valve will leak.

Head Pressure Control Valve

1. Purge system of refrigerant
2. Break off process tube on the top of the OLD head pressure control valve.
3. Unsweat old valve from tubing.
4. Unsweat old dryer from tubing.
5. Install new valve in place, check for correct connections and be sure the number on the side of the valve is "180"
6. Wrap the new valve body in wet cloths to heat sink the valve body.
7. Sweat in the new valve and the new dryer.
8. Evacuate the system, and weigh the nameplate charge into the receiver.

CHARGING PROCEDURES

Extra care must be taken when recharging this remote system. No liquid refrigerant may be placed in the system at the compressor. DO NOT use the

valves at the front of the unit for weighing in the charge. All liquid refrigerant must be weighed into the receiver through the "front seated" king valve.

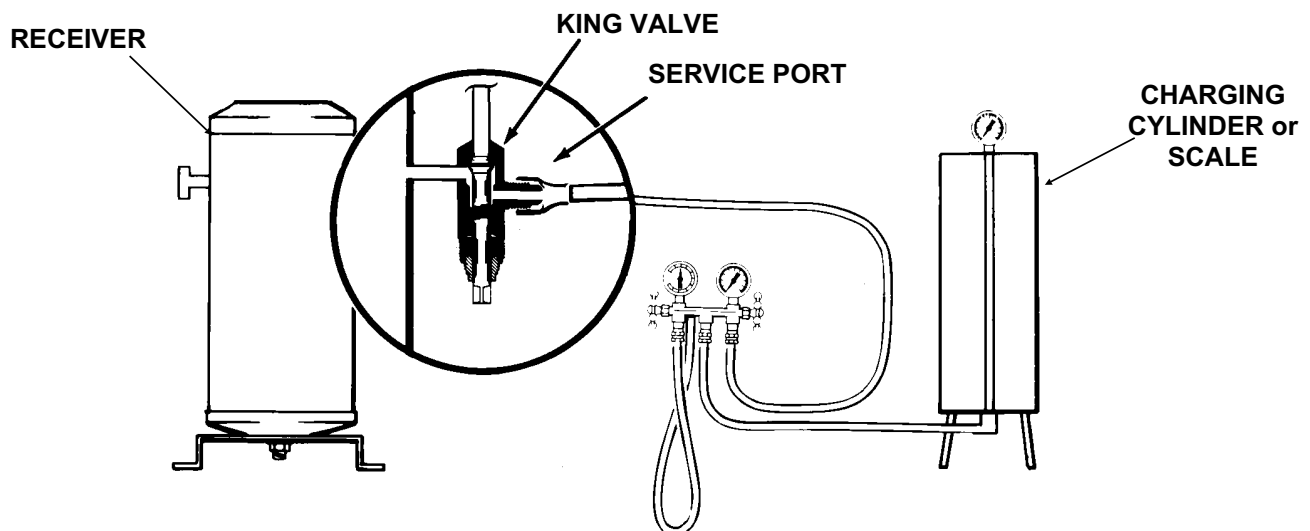

What to Do Before Calling for Service

If the machine is off, not making ice:

1. Check the water supply to the ice machine. The machine is designed to shut off if there is no water to it. Check the filters if there are any.
2. Check the power supply to the machine. Reset the breaker if it is tripped.
3. If both water and power have been checked and are available, try switching the power Off and then On. After 2 minutes the machine should restart.

If this procedure restarts the machine, service should be called the next time the machine stops.