

NME1854R & FME2404R SERVICE PARTS

This parts list contains the service parts and wiring diagrams for this model. Check the model number in question to be sure that it is applicable to this parts list.

Compressors changed in mid 2012.

Table of Contents

Cabinet Assembly	Page 2
Refrigeration System	Page 3
Water System, Water Seal	Page 4
Gearmotor	Page 5
NME Evaporator, Bin Controls	Page 6
FME Evaporator, Bin Controls	Page 7
Control Box	Page 8
Compressors and Starting Components	Page 9
Remote Condenser - ERC302	Page 10
Remote Condenser - PR2C240	Page 11
Component Layout Diagram 208-230/60/1	Page 12
Schematic Diagram 208-230/60/1	Page 13
Component Layout Diagram 208-230/60/3	Page 14
Schematic Diagram 208-230/60/3	Page 15

NME1854R & FME2404R SERVICE PARTS

Cabinet Assembly

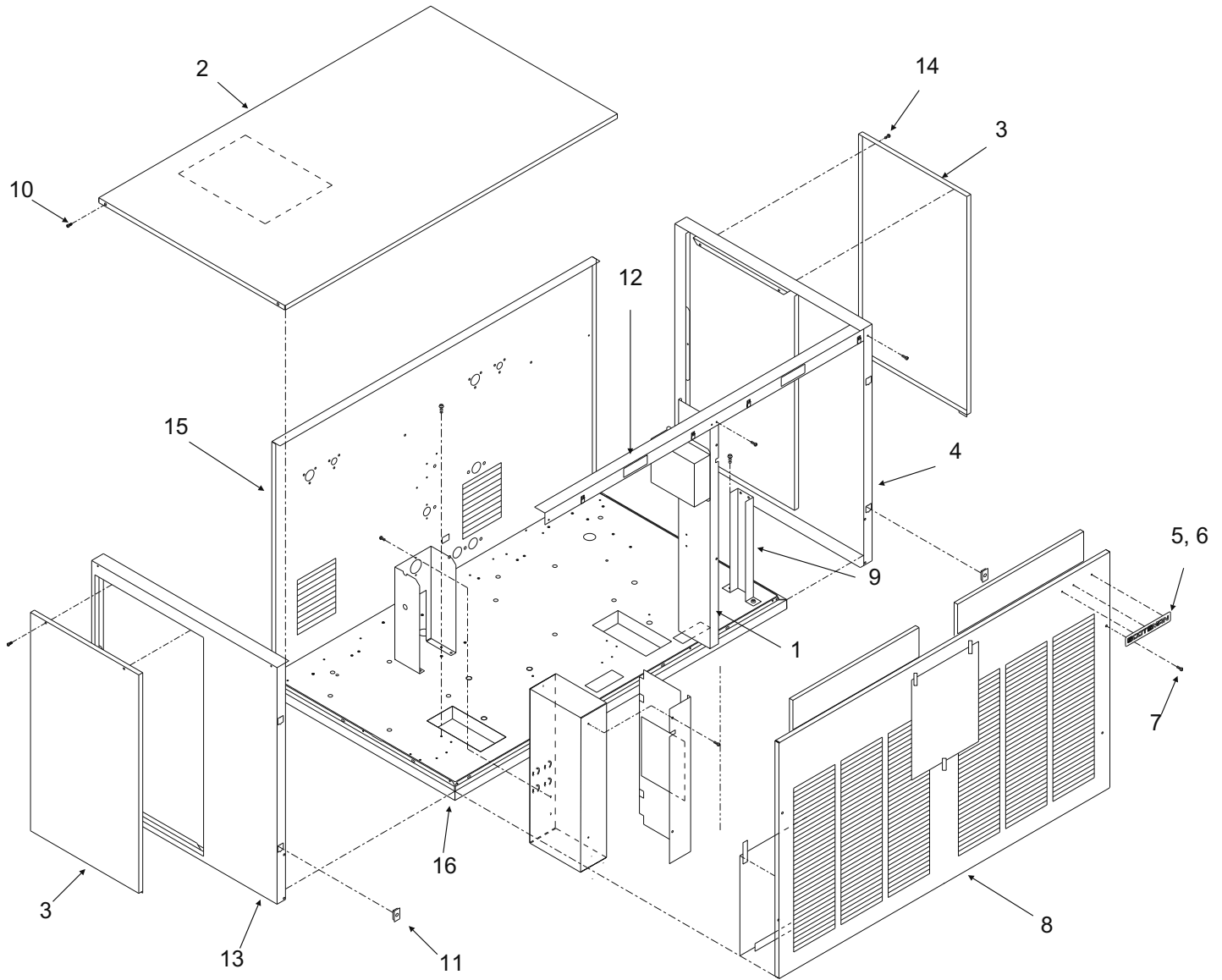

ITEM NUMBER	PART NUMBER	DESCRIPTION	ITEM NUMBER	PART NUMBER	DESCRIPTION
1	A34286-001	Center Support	8	A34294-002	Front Panel, S.S
2	A32461-002	Top Panel, S.S.	9	A37482-001	Reservoir bracket
3	A34038-002	Service Panel, S.S.	10	03-1531-01	Screw
4	A33292-002	Right Side Panel, S.S.	11	02-0836-00	Catch
5	03-0271-00	Speed Clip	12	A34287-001	Support
6	15-0808-01	Emblem, gray	13	A32435-002	Left Side Panel, S.S.
7	03-1419-22	Screw	14	03-1404-12	Screw
			15	A36517-002	Rear Panel
			16.	A36554-001	Base

NME1854R & FME2404R SERVICE PARTS

Refrigeration System

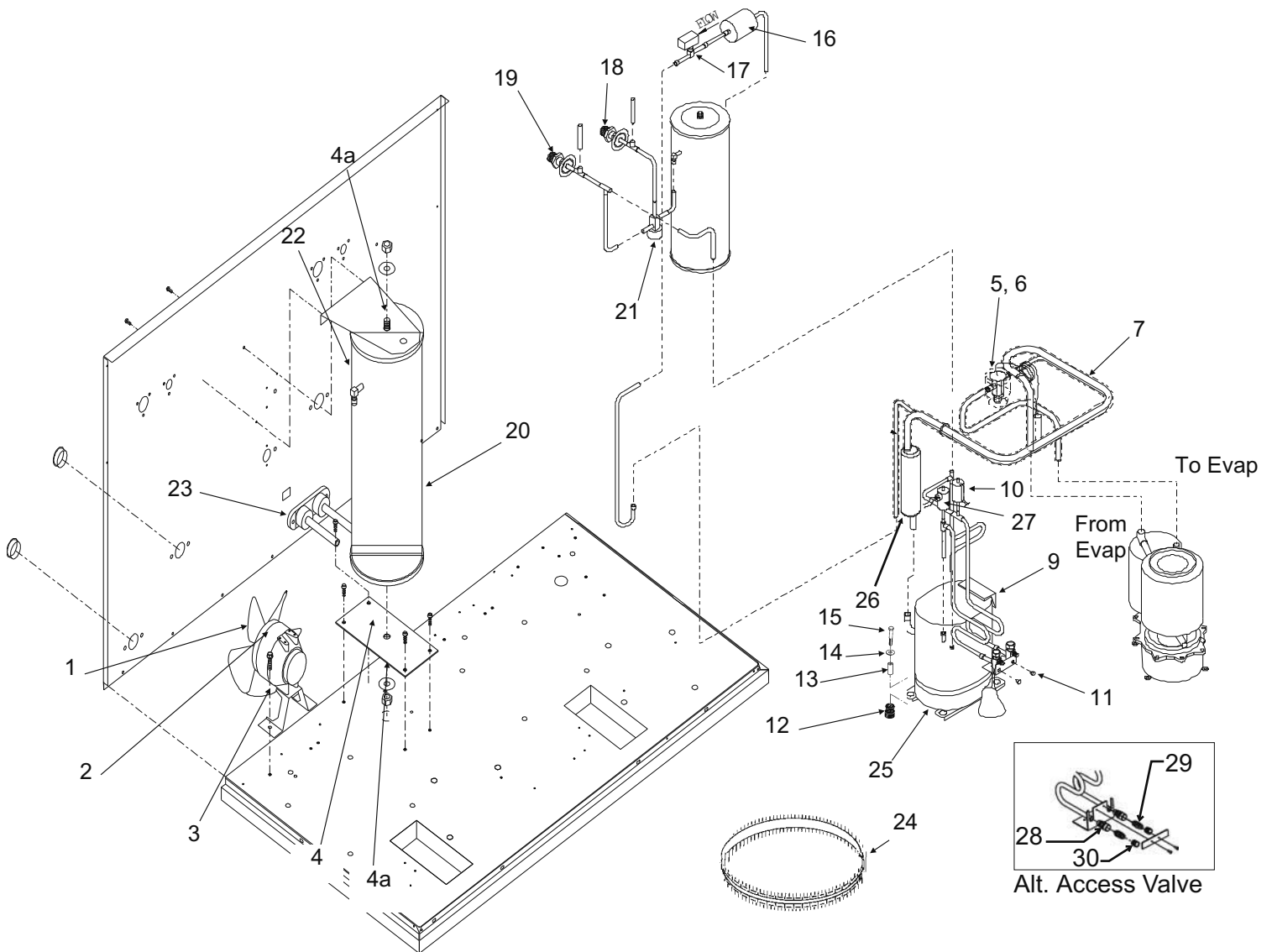

ITEM NUMBER	PART NUMBER	DESCRIPTION	ITEM NUMBER	PART NUMBER	DESCRIPTION
1	18-8708-01	Fan Blade	17	12-2135-02	Liquid line valve
2	12-1576-02	Fan Motor	18	16-0850-01	Liquid line fitting
3	A35246-001	Fan Bracket	19	16-0850-03	Discharge line fitting
4	A31801-002	Bracket	20	16-0761-01	Receiver
4a	03-1406-13	Nut	21	11-0422-25	Discharge pressure control
5	A32961-020	Insulation Kit (3 piece)	22	A32968-001	Receiver bracket
6	11-0488-21	Thermo Expansion Valve	23	02-3692-22	Drain fitting
7	A36496-001	Suction Line	24	12-1868-03	Crankcase heater - RS comp
8	A34285-001	Filler panel		12-3043-02	Crankcase heater - RST comp
9	16-0832-20	Access valve	25	see page 9	Compressor
9a	16-0832-02	Stem cap	26	16-0778-21	Accumulator
9b	16-0832-03	Core cap	27	11-0502-21	Low pressure cut out
10	11-0501-22	Hi Pressure Cut Out	28	16-1137-01	Access valve body
11	03-1645-01	Screw	29	16-1139-01	Core
12	18-2200-28	Grommet	30	16-1140-01	Cap
13	18-2200-27	Sleeve			
14	03-1407-07	Washer			
15	03-1405-20	Cap Screw			
16	02-3319-02	Dryer			

NME1854R & FME2404R SERVICE PARTS

Water System, Water Seal

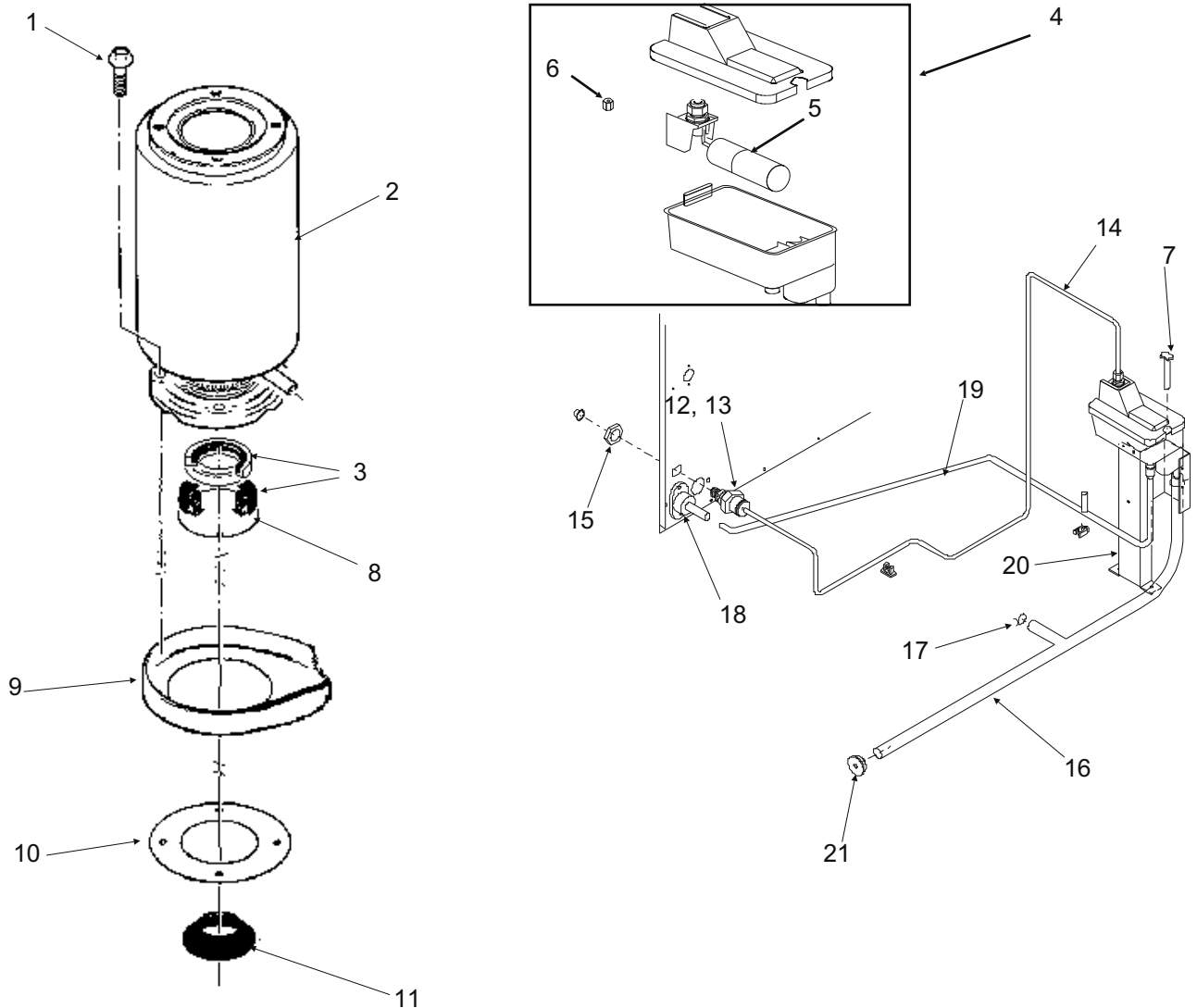

ITEM NUMBER	PART NUMBER	DESCRIPTION	ITEM NUMBER	PART NUMBER	DESCRIPTION
1	03-1405-41	Cap Screw	15	03-1394-01	Pal Nut
2	A32890-020	Evaporator	16	A36154-001	Evap. water inlet tube
3	02-0929-23	Water Seal	17	02-1338-00	Hose clamp
4	02-3266-01	Reservoir & valve	18	02-3692-22	Drain fitting
5	02-3266-02	Float valve	19	02-3826-01	Res. overflow hose (right)
6	02-3266-03	Plunger/seat		02-3826-02	Res. overflow hose (left)
7	12-2760-21	Water Level Sensor	20	A37482-001	Reservoir bracket
8	A32777-001	Retaining Ring for Seal	21	13-0840-01	Rubber cap
9	02-3837-01	Drip Pan			
10	13-0704-00	Gasket			
11	02-4663-01	Water Shed			
12	16-0835-01	Inlet fitting for plastic tubing			
13	16-1039-01	Male connector for plastic			
14	13-0895-01	Inlet tubing, 4 ft. req.			

NME1854R & FME2404R SERVICE PARTS

Gearmotor

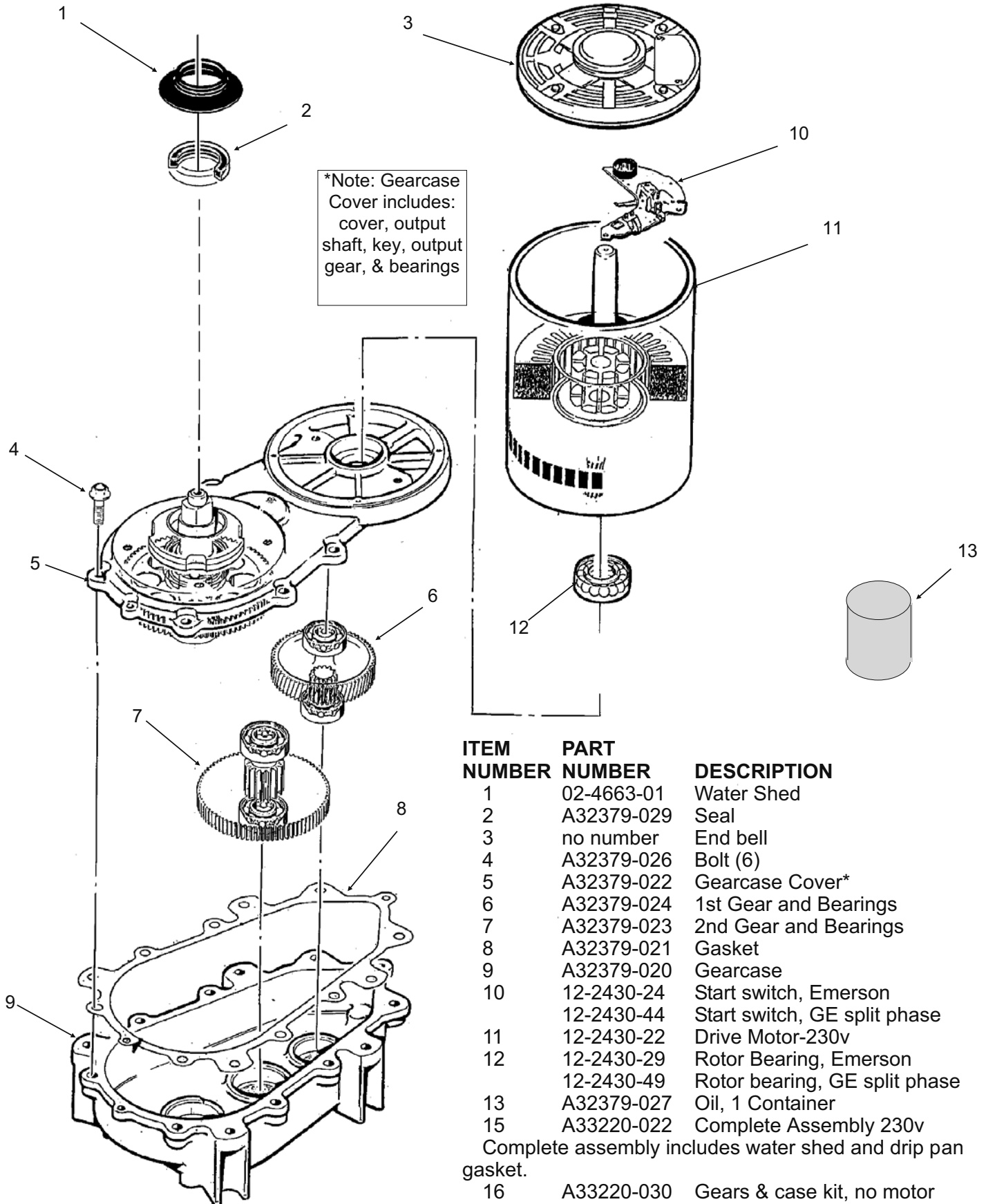

ITEM NUMBER	PART NUMBER	DESCRIPTION
1	02-4663-01	Water Shed
2	A32379-029	Seal
3	no number	End bell
4	A32379-026	Bolt (6)
5	A32379-022	Gearcase Cover*
6	A32379-024	1st Gear and Bearings
7	A32379-023	2nd Gear and Bearings
8	A32379-021	Gasket
9	A32379-020	Gearcase
10	12-2430-24	Start switch, Emerson
	12-2430-44	Start switch, GE split phase
11	12-2430-22	Drive Motor-230v
12	12-2430-29	Rotor Bearing, Emerson
	12-2430-49	Rotor bearing, GE split phase
13	A32379-027	Oil, 1 Container
15	A33220-022	Complete Assembly 230v
Complete assembly includes water shed and drip pan gasket.		
16	A33220-030	Gears & case kit, no motor

NME1854R & FME2404R SERVICE PARTS

NME Evaporator, Bin Controls

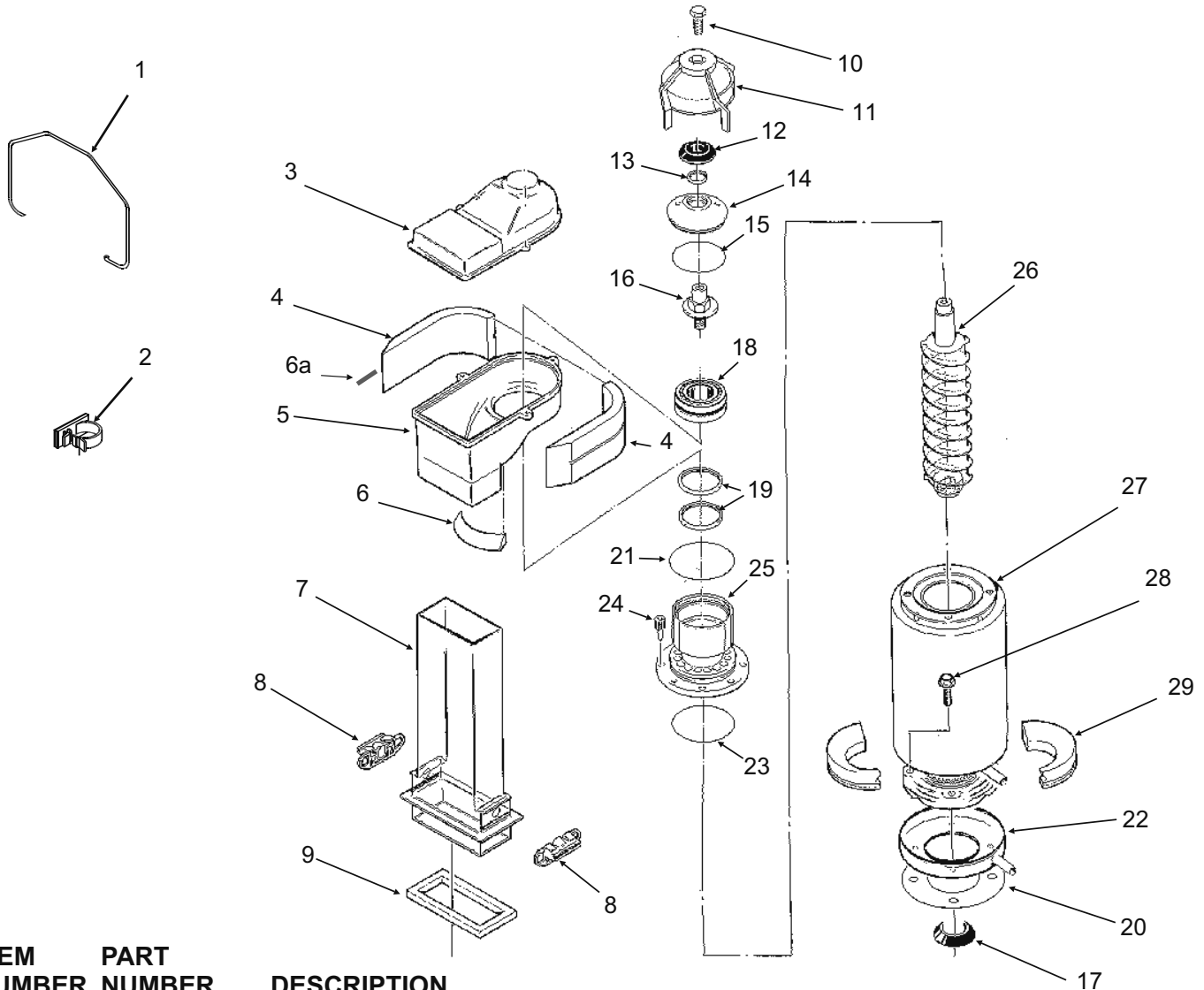

ITEM NUMBER	PART NUMBER	DESCRIPTION
1.	A34969-001	Bail clip
2.	02-3268-01	Drain tube holder
3.	02-2930-04	Ice Chute Cover
4.	A32963-001	Insulation Top (half)
5.	02-2926-01	Ice Chute Body
6.	A33102-001	Insulation Collar Inside
6a	A35419-020	Strap kit
7.	02-2929-04	Ice Chute Lower
8.	A37708-021	Bin Controls Assy. (set of 2)
9.	A32930-001	Chute Gasket
10.	03-1405-52	Hex Cap Screw
11.	02-3001-01	Ice Sweep
12.	13-0871-01	Water Shed
13.	02-2978-01	Lip Seal
14.	02-3128-20	Breaker Cover
15.	13-0617-52	O-Ring
16.	08-0660-01	Auger Stud & washer
17.	02-4663-01	Water Shed
18.	A34559-020	Bearing
19.	02-2977-01	Lip Seal
20.	13-0704-00	Drip Pan Gasket
21.	13-0617-54	O-Ring
22.	02-3837-01	Drip Pan
23.	13-0617-45	O-Ring
24.	03-1544-08	Soc. Head Screw
25.	A32900-020	Breaker (includes 12-15, 18, 19, 21, 23)
26.	A38071-022	Auger
27.	A32890-020	Evaporator
28.	03-1420-03	Cap Screw
29.	02-4358-01	Insulation

NME1854R & FMF2404R SFRVICF PARTS

FME Evaporator, Bin Controls

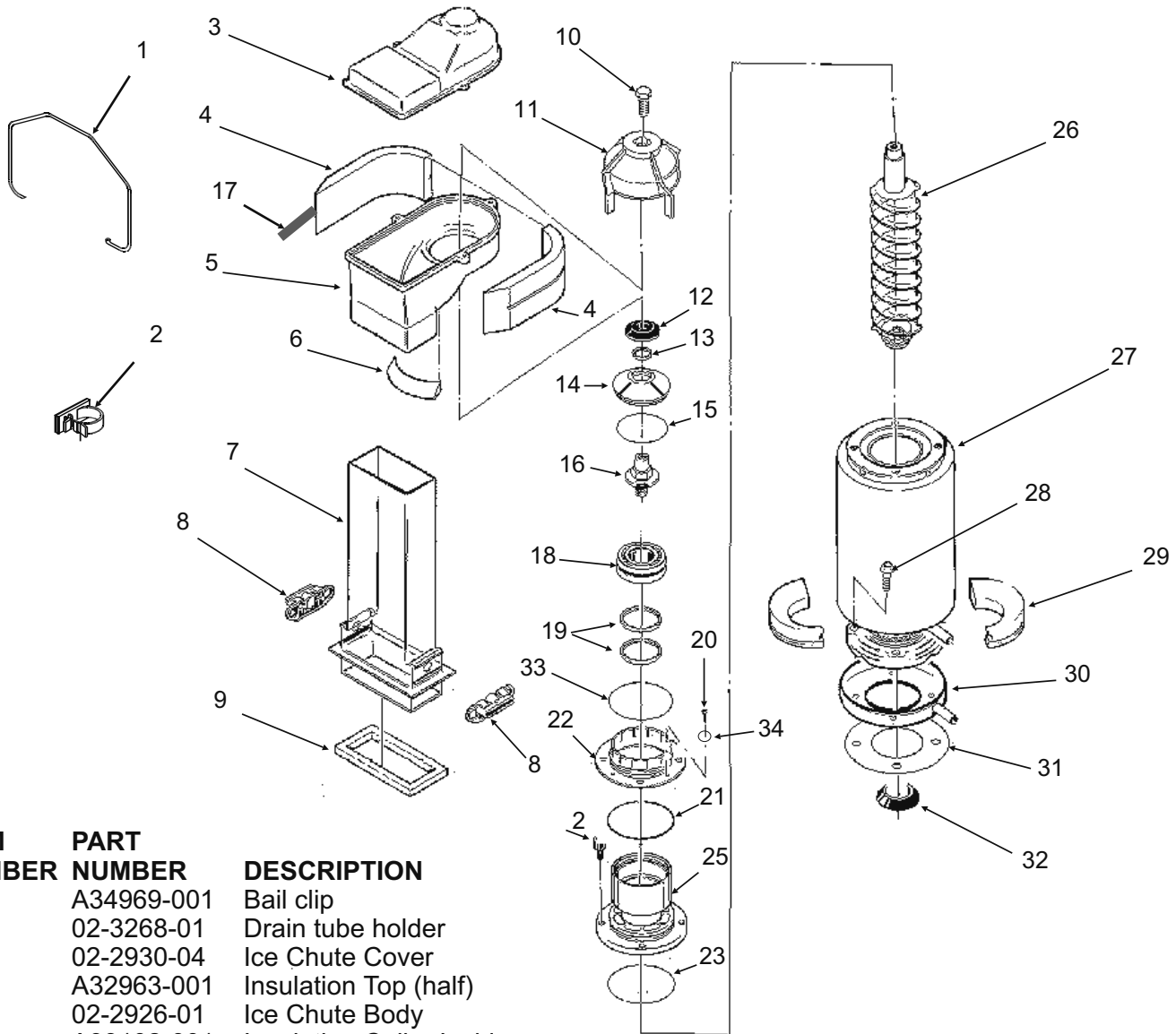

ITEM NUMBER	PART NUMBER	DESCRIPTION
1.	A34969-001	Bail clip
2.	02-3268-01	Drain tube holder
3.	02-2930-04	Ice Chute Cover
4.	A32963-001	Insulation Top (half)
5.	02-2926-01	Ice Chute Body
6.	A33102-001	Insulation Collar Inside
7.	02-2929-04	Ice Chute Lower
8.	A37708-021	Bin Controls Assy. (set of 2)
9.	A32930-001	Chute Gasket
10.	03-1405-52	Hex Cap Screw
11.	02-3001-01	Ice Sweep
12.	13-0871-01	Water Shed
13.	02-2978-01	Lip Seal
14.	02-3128-20	Breaker Cover
15.	13-0617-54	O-Ring
16.	08-0660-01	Auger Stud, thrust Washer
17.	A35419-020	Strap kit
18.	A34559-020	Bearing
19.	02-2977-01	Lip Seal
20.	03-1405-27	Screw
21.	13-0617-52	O-Ring
22.	02-2916-01	Slotted Collar
23.	13-0617-45	O-Ring
24.	03-1544-08	Soc. Head Screw
25.	A34505-020	Breaker (Divider) (includes 12-15, 18, 19, 22, 21, 23)
26.	A38071-022	Auger
27.	A32890-020	Evaporator
28.	03-1420-03	Cap Screw
29.	02-4358-01	Insulation
30.	02-3837-01	Drip Pan
31.	13-0704-00	Drip Pan Gasket
32.	02-4663-01	Water Shed
33.	13-0617-49	O-Ring
34.	03-1408-36	Washer

NME1854R & FME2404R SERVICE PARTS

Control Box

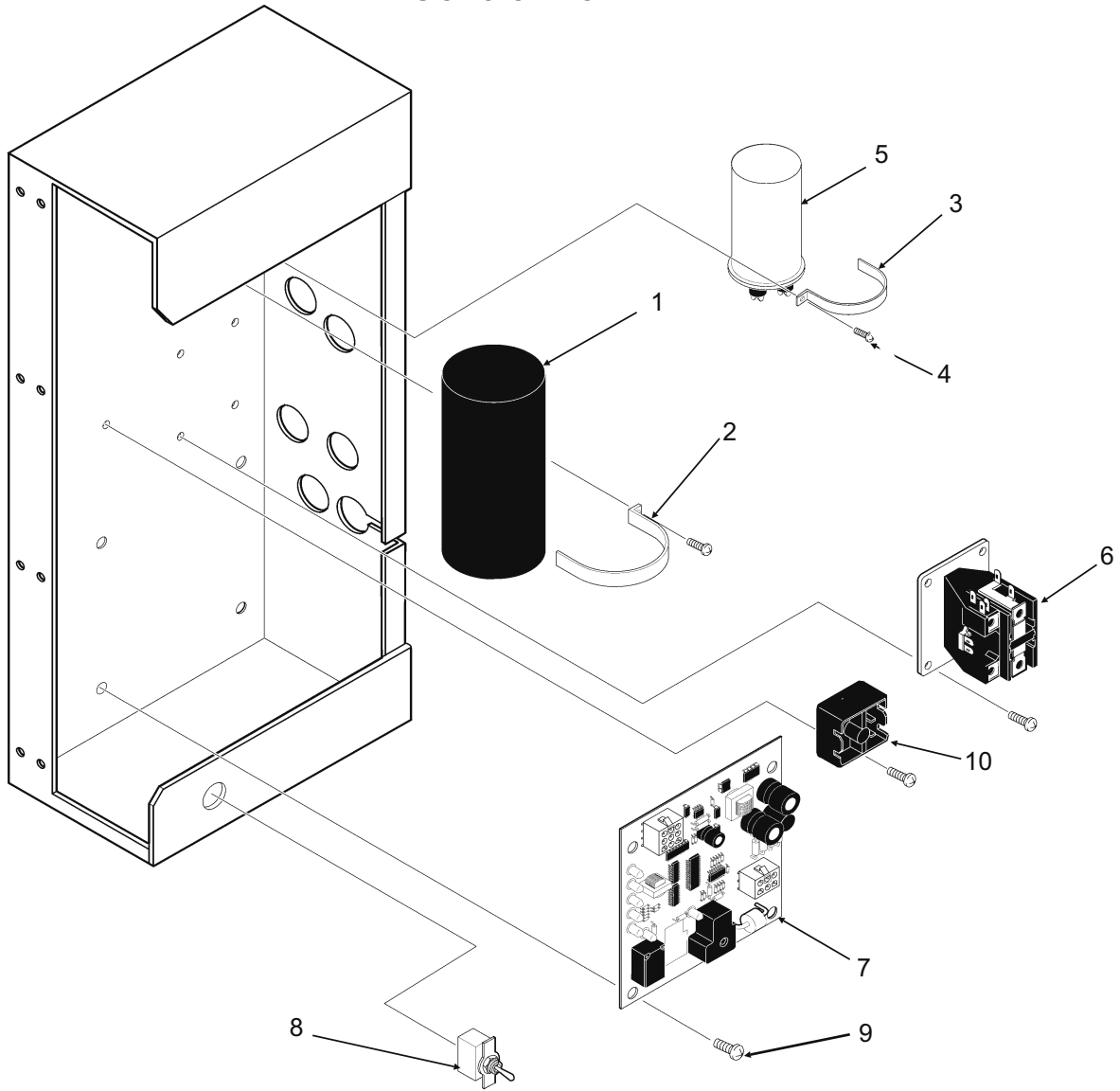

ITEM NUMBER	PART NUMBER	DESCRIPTION
1	see next page	Start Capacitor.
2.	A35971-001	Start Capacitor Bracket
3.	A35971-002	Run Cap Bracket
4.	03-1638-03	Screw
5.	see next page	Run Capacitor
6.	12-2469-02	Single Phase Contactor
	12-2533-02	Three Phase Contactor

ITEM NUMBER	PART NUMBER	DESCRIPTION
7	12-2835-22	Circuit Board
8.	12-0426-02	Mode Switch
9.	12-2350-01	Spacer/screw
10	see next page	Potential Relay

Separate From The Control Box

11.	12-2070-04	Fan Motor Relay (in a separate control box)
12.	A37861-001	Control box cover

NME1854R & FME2404R SERVICE PARTS

Compressors and Starting Components

RS70 Compressor (example **RS70C1E-PFV-213**), used until mid June 2012. Refer to this parts list for compressor service parts on units manufactured before serial number 12061320011941.

18-8768-22	Compressor 208-230/60/1
18-1901-54	Start Capacitor, 60 Hz
18-1902-45	Run Capacitor, 60 Hz
18-1903-33	Potential Relay 60 Hz Overload is internal
18-8768-24	Compressor 208-230/60/3 Overload is internal
18-8772-26	Compressor 230/50/1
18-1901-53	Start capacitor, 50 Hz
18-1902-53	Run capacitor, 50 Hz
18-1903-29	Potential relay, 50 Hz
18-8772-21	Overload

Note: Replacement compressors include a new dryer, and single phase 60 Hz replacements include the starting components.

Because the RST compressor is not an exact replacement for the RS, the kits below include the tubing and starting components needed to install the RST compressor in place of the RS.

RST70 Compressor, (example **RST70C1E-PFV**) use began with serial number 12061320011941. Refer to this parts list for compressor service parts on any unit after that serial number.

18-8955-22	Compressor 208-230/60/1
18-1901-20	Start Capacitor, 60 Hz
18-1902-67	Run Capacitor, 60 Hz
18-1903-54	Potential Relay 60 Hz Overload is internal
18-8955-23	Compressor 208-230/60/3
18-8955-53	Overload

Note: Replacement compressors include a new dryer, and single phase 60 Hz replacements include the starting components.

No 50 Hz RST compressor was used in production. Continue to use 18-8772-26 as a replacement for 50 Hz compressors in these models.

NME1854R & FME2404R SERVICE PARTS

Remote Condenser - ERC302

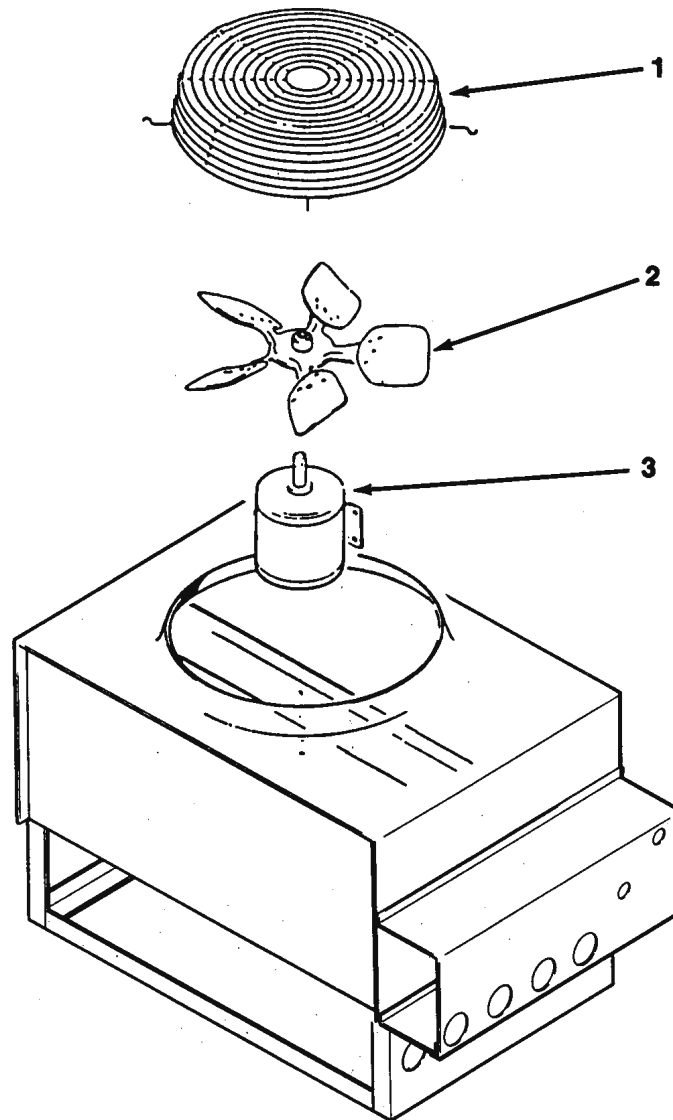

ERC302

ITEM NUMBER	PART NUMBER	DESCRIPTION
1	02-3575-01	Fan guard
2	18-8800-01	Fan blade
3	18-8796-32	Fan motor
4.	16-1057-01	Line connection, female half 3/8"
5.	16-1057-02	Line connection, female half 1/2"

NME1854R & FME2404R SERVICE PARTS

Remote Condenser - PR2C240

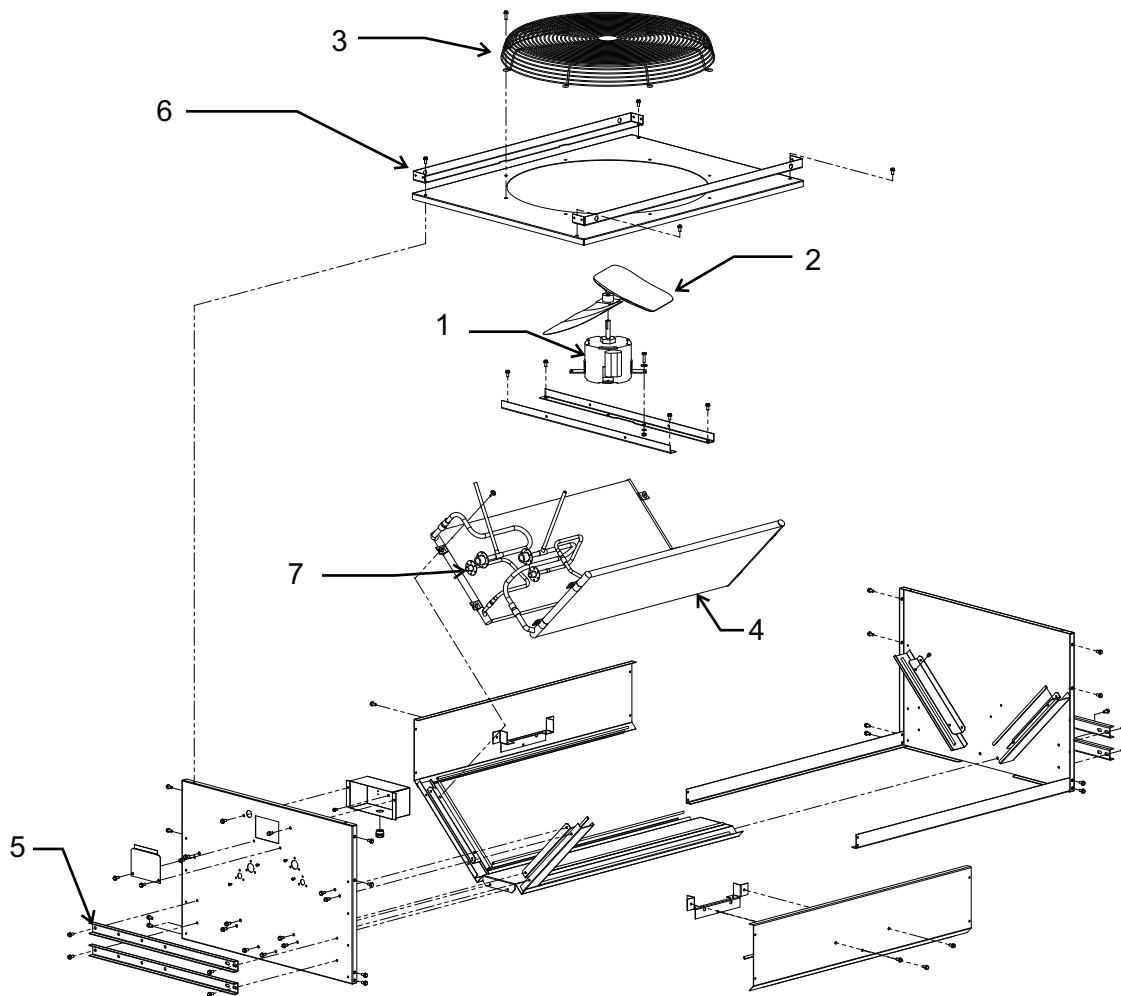

ITEM NUMBER	PART NUMBER	DESCRIPTION
1	Fan motor	12-2717-01
2	Fan blade	18-8820-01
3	Fan guard	02-3770-01
4	Coil	18-8945-22
5	Leg	A39169-001
6	Leg brace	A39756-001
7	16-0850-01	Quick connect, discharge
	16-0850-03	Quick connect, liquid

NME1854R & FME2404R SERVICE PARTS

Component Layout Diagram 208-230/60/1

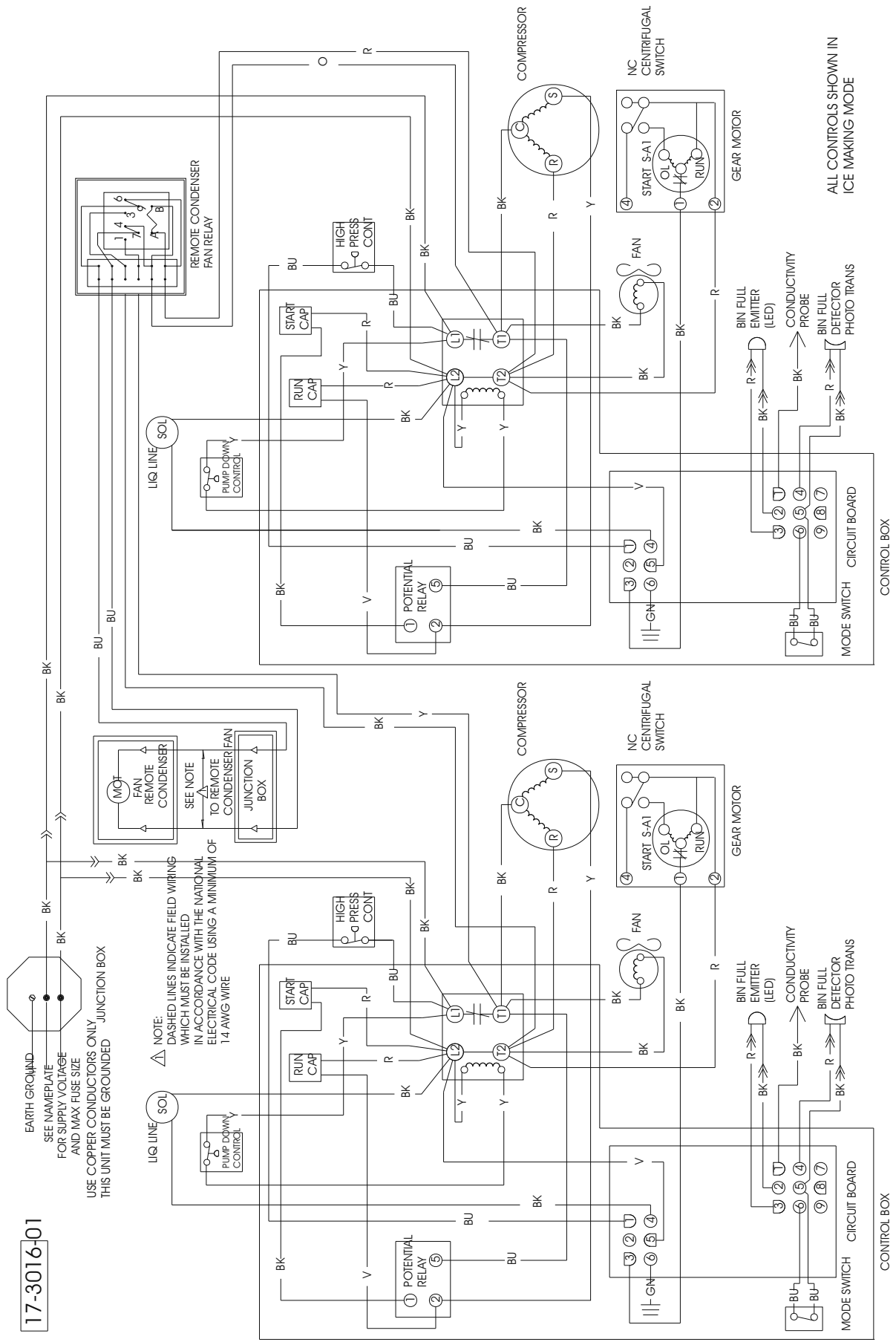

NME1854R & FME2404R SERVICE PARTS

Schematic Diagram 208-230/60/1

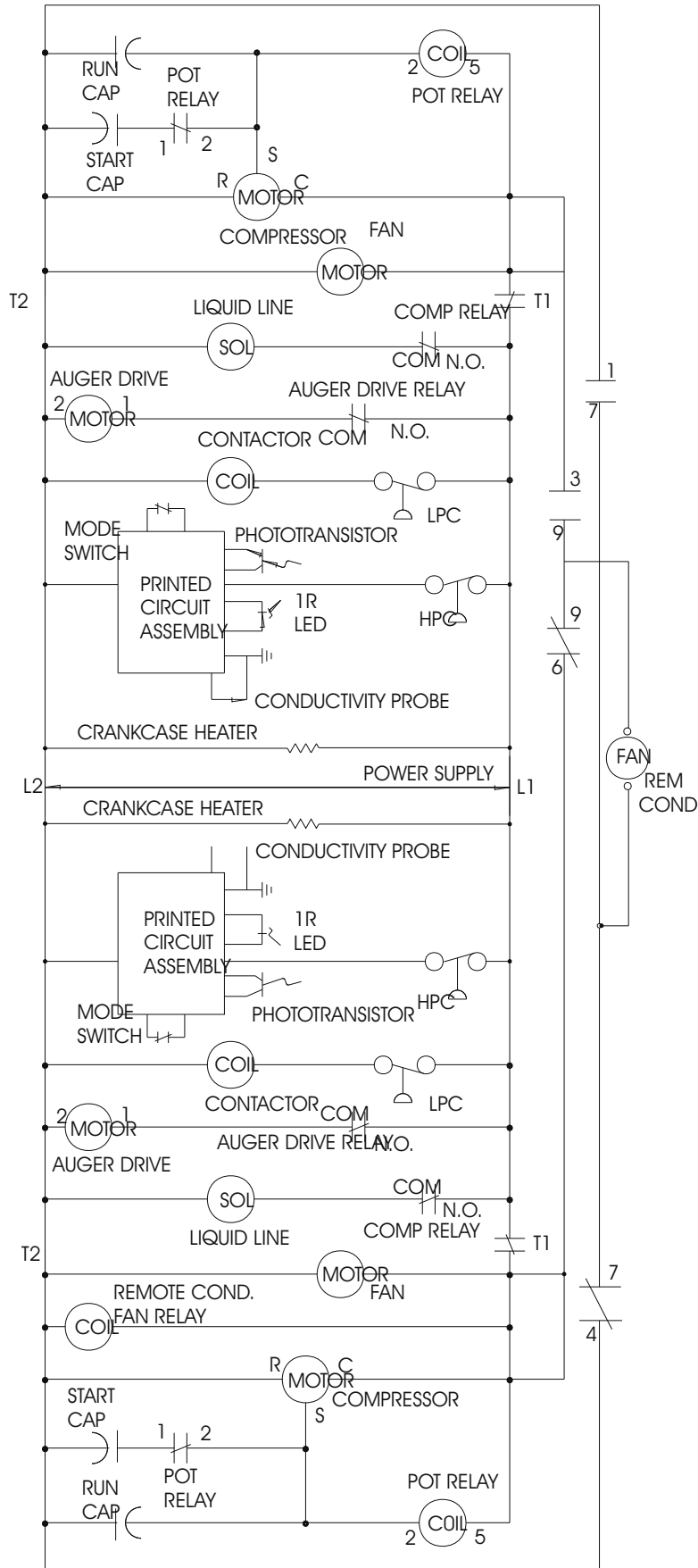

NME1854R & FME2404R SERVICE PARTS

Component Layout Diagram 208-230/60/3

17-3018-01

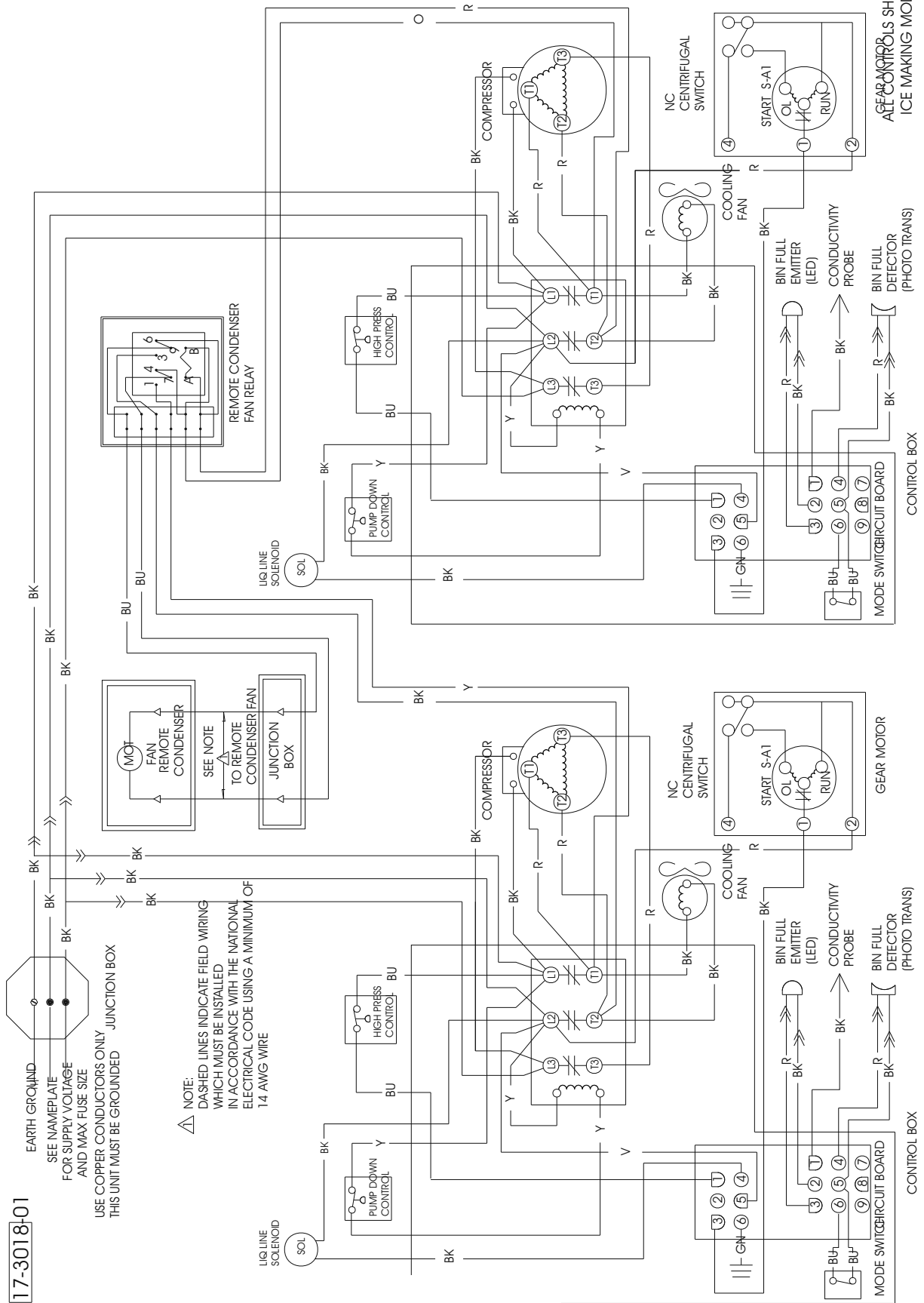

NME1854R & FME2404R SERVICE PARTS

Schematic Diagram 208-230/60/3

