

INTRODUCTION

To the owner or user: The service manual you are reading is intended to provide you, and the maintenance or service technician, with the information needed to install, start up, clean, maintain, and service this ice system.

This product contains 2 separate ice making systems in one cabinet.

Table of Contents

FOR THE INSTALLER	Page 2
FOR THE INSTALLER: Environmental Limitations	Page 3
FOR THE INSTALLER	Page 4
FOR THE INSTALLER: Location	Page 5
FOR THE PLUMBER	Page 6
FOR THE ELECTRICIAN	Page 7
FOR THE INSTALLER	Page 8
START UP	Page 9
COMPONENT DESCRIPTION	Page 10
COMPONENT DESCRIPTION	Page 11
COMPONENT DESCRIPTION: Control Box	Page 12
ELECTRICAL SEQUENCE	Page 13
OPERATION: Performance	Page 14
OPERATION: Water	Page 15
OPERATION: Refrigeration	Page 16
CLEANING and SANITATION	Page 17
SENSOR MAINTENANCE	Page 18
BEARING MAINTENANCE	Page 19
AIR COOLED CONDENSER MAINTENANCE	Page 20
AUGER MAINTENANCE	Page 21
SERVICE DIAGNOSIS:	Page 22
SERVICE DIAGNOSIS	Page 23
CONTROL SYSTEM DIAGNOSTICS	Page 24
REMOVAL AND REPLACEMENT: Water Reservoir & Bin Controls	Page 25
REMOVAL AND REPLACEMENT: Bearing And Breaker	Page 26
REMOVAL AND REPLACEMENT: Auger	Page 27
REMOVAL AND REPLACEMENT: Water Seal	Page 28
REMOVAL AND REPLACEMENT: Evaporator	Page 29
REMOVAL AND REPLACEMENT: Gearmotor	Page 30
REMOVAL AND REPLACEMENT: Fans	Page 31
REFRIGERATION SERVICE	Page 32

This manual was printed on recycled paper. Keep it for future reference.

Note the Warning symbol where it appears, it marks a possible hazard.



NME1854 & FME2404 FOR THE INSTALLER

The FME2404 and the NME1854 are modular flakers designed to fit the following Scotsman storage bins:

- B90 and extensions (with bin top KBT18)
- BH800 no bin top required.
- BH900 using bin top KBT14.
- BH1366 or BH1666, no bin top required.

When installing a new system, check to be sure that you have everything you need before beginning:

- Correct Bin
- Correct Ice Machine
- Correct Bin Top (if required)
- All kits, legs, and information required for the specific job.

Note: Allow 6" behind and 6" above the unit for air circulation, utility connections, and service.

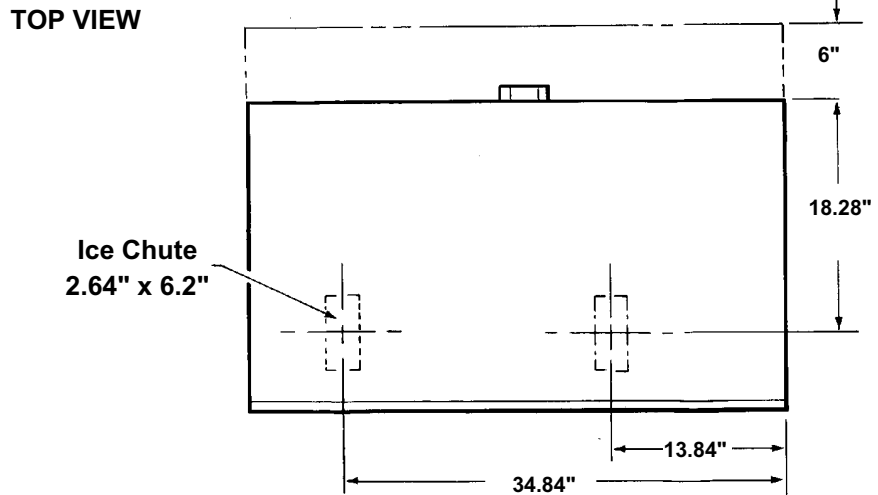
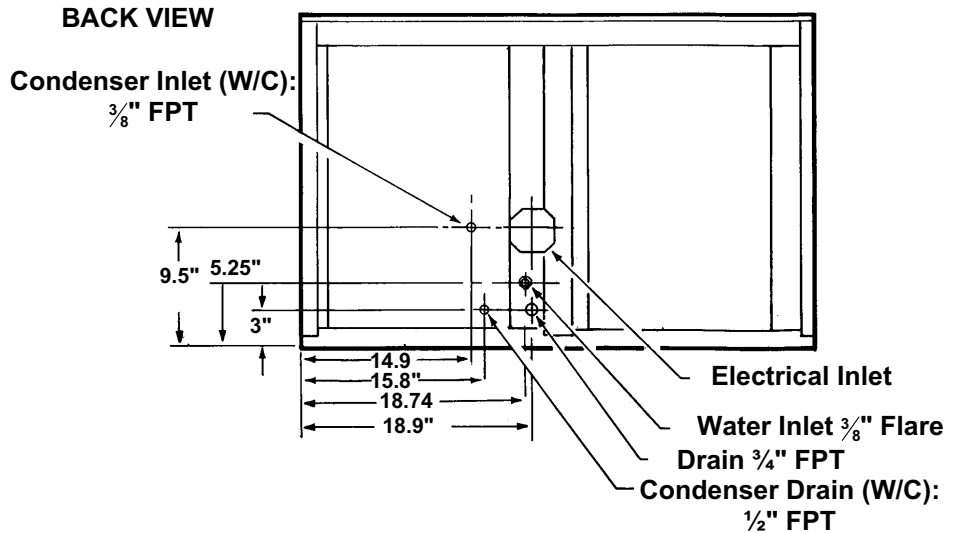

SPECIFICATIONS: Ice Machine

Model	Series	Dimensions (w/o Bin) W x D x H	Basic Electrical	Ice Type	Condenser Type	Minimum Circuit Ampacity	Max. Fuse Size	Refrigerant Charge, R-404A
FME2404AS-32	A or B	42" x 24" x 27"	208-320/60/1	Flake	Air	21.0	25	30 oz
FME2404WS-32	A	42" x 24" x 27"	208-320/60/1	Flake	Water	19.8	25	24 oz.
FME2404WS-32	B	same	208-230/60/1	Flake	Water	19.8	25	22 oz.
FME2404AS-3	A or B	42" x 24" x 27"	208-230/60/3	Flake	Air	15.9	20	30 oz
FME2404WS-3	A	42" x 24" x 27"	208-230/60/3	Flake	Water	14.6	20	24 oz.
FME2404WS-3	B	same	208-230/60/3	Flake	Water	14.6	20	24 oz
NME1854AS-32	A or B	42" x 24" x 27"	208-230/60/1	Nugget	Air	21.0	25	30 oz
NME1854WS-32	A	42" x 24" x 27"	208-230/60/1	Nugget	Water			24 oz.
NME1854WS-32	B	same	208-230-60/1	Nugget	Water			22 oz.
NME1854AS-3	A or B	42" x 24" x 27"	208-230/60/3	Nugget	Air	15.9	20	30 oz
NME1854WS-3	A	42" x 24" x 27"	208-230/60/3	Nugget	Water	14.6	20	24 oz.
NME1854WS-3	B	same	208-230/60/3	Nugget	Water	14.6	20	22 oz

* Per system. Always go by the nameplate

Minimum circuit ampacity is used to determine wire size and type per the National Electric Code.

FOR THE INSTALLER: Environmental Limitations

Installation Limitations:

This ice system is designed to be installed indoors, in a controlled environment:

	Min	Max
Air Temperature	50°F	100°F
Water Temperature	40°F	100°F
Water Pressure	20 PSI	80 PSI
Voltage	198 VAC	253 VAC

(Compared to the nameplate)

Operating the machine outside of the limitations is misuse and can void the warranty.

Water Limitations:

An ice machine is a food manufacturing plant; it takes a raw material, water, and turns it into a food product, ice. The purity of the water is very important in obtaining pure ice and in maximizing product life. This is not intended as a complete resource for water related questions, but it does offer these general recommendations:

1. Check with a water treatment specialist for a water test, and recommendations regarding filters and treatment.
2. In most cases, the water used to make ice should be filtered or treated, depending upon the water. *There is no one type of water filter that will be effective in all situations.* That is why a water test is important.

RO Water Limitation: Water conductivity must be no less than 35 microSiemens/cm.

Scotsman Ice Systems are designed and manufactured with the highest regard for safety and performance. They meet or exceed the standards of UL, NSF, and CUL.

Scotsman assumes no liability or responsibility of any kind for products manufactured by Scotsman that have been altered in any way, including the use of any part and/or other components not specifically approved by Scotsman.

Scotsman reserves the right to make design changes and/or improvements at any time. Specifications and design are subject to change without notice.

NME1854 & FME2404

FOR THE INSTALLER

Typical Storage Bin with Extension and Bin Top

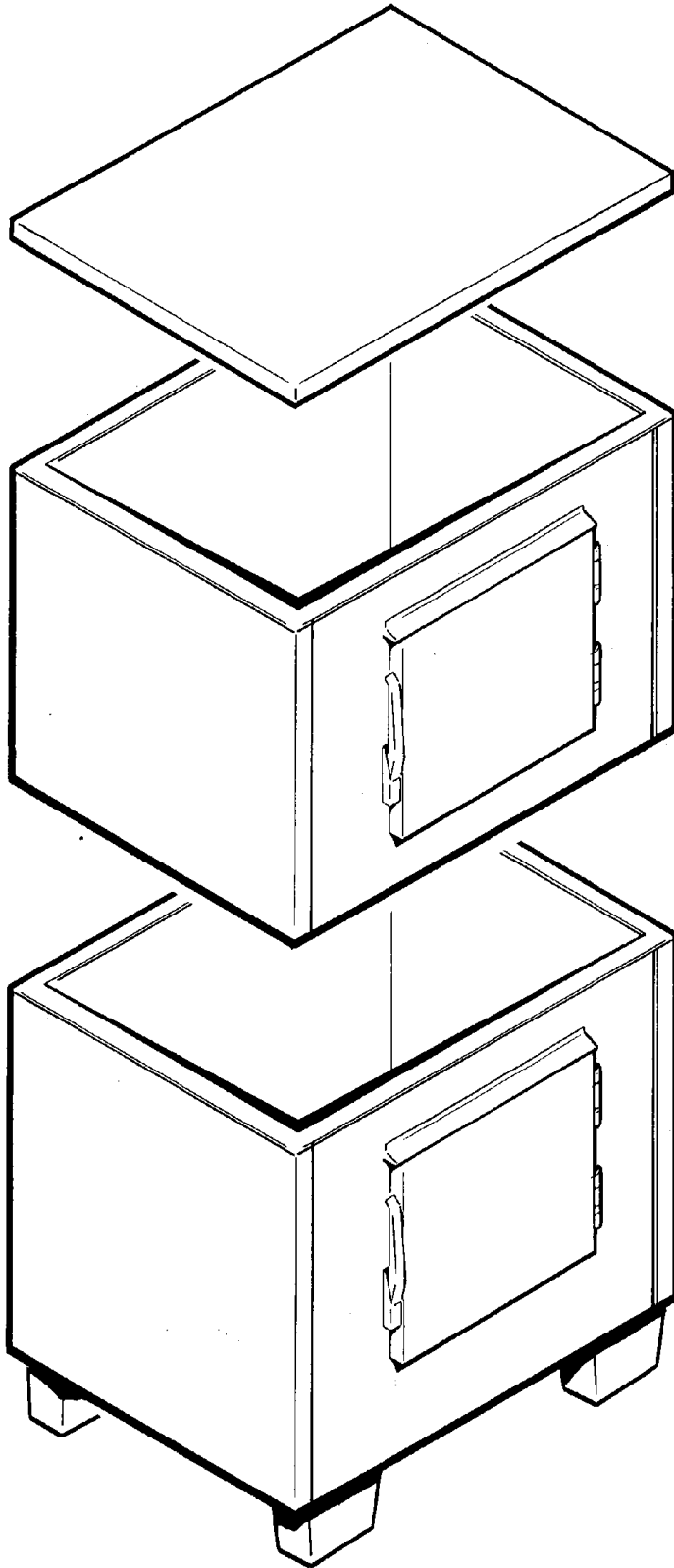

Location:

After uncrating and inspection the unit is ready for installation. Install the machine in a location where it has enough space around it to be accessible for service, and reserve a minimum of 6" at the back for air circulation on air cooled models.

Avoid hot, dirty and crowded locations. Be sure that the location for the machine is within the limitations described on page 3.

Storage Bin:

Tip the storage bin on its back, using parts of the carton to protect the exterior finish. Install the legs into the threaded holes in the bottom of the bin. Turn the leg levelers all the way in preparation for leveling later. Return the bin to the upright position, remove paper covering the bin gasket.

Note: Do not push bin into position, instead lift it there. Pushing a bin, especially one with ice in it, can cause damage to the legs and the leg mounts.

Install the appropriate bin top on the bin, according to the instructions for the bin top.

ice machine:

The machine is heavy, so the use of a mechanical lift is recommended for lifting the machine high enough to install on top of the bin. After the unit is placed on the bin, line it up so it is even with the back side. Secure the machine to the bin with the hardware provided with the machine.

Remove the front panel and remove any shipping blocks.

FOR THE INSTALLER: Location

ALLOW ROOM
FOR AIR
CIRCULATION
AND SERVICE
ACCESS

DO NOT STACK ANYTHING IN
FRONT OF THE MACHINE

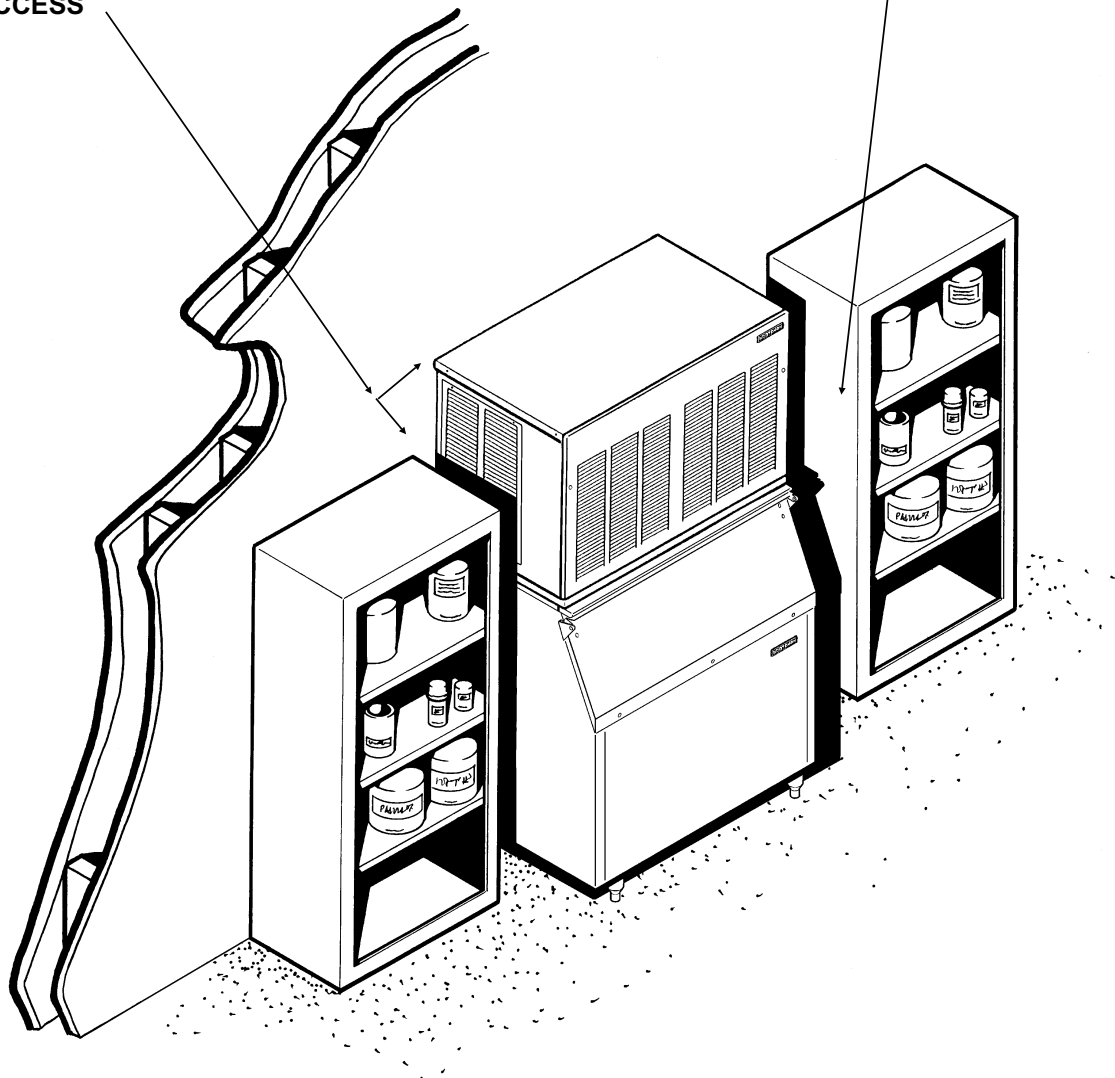

NME1854 & FME2404 FOR THE PLUMBER

CONFORM TO ALL APPLICABLE CODES

Water Inlet

Air Cooled Models: Connect to a water supply that is cold and potable. Use $\frac{3}{8}$ " O.D. copper tubing, and connect to the single $\frac{3}{8}$ " male flare at the back of the cabinet. This connection supplies water to both ice making systems. Install a hand valve near the machine to control the water supply.

Water Treatment: In most areas, a water filter of some type will be useful. In areas where the water is highly concentrated with minerals the water should be tested by a water treatment specialist, and the recommendations of the specialist regarding filtration and/or treatment should be followed.

Water Cooled Models: A separate $\frac{3}{8}$ " O.D. copper line is recommended, with a separate hand valve to control it. It is connected to a single $\frac{3}{8}$ " FPT condenser inlet at the back of the cabinet. This connection supplies water to both water cooled condensers. The water pressure to all lines must always be above 20 psig, and below 80 psig.

Drains

Air Cooled Models: Connect a drain tube to the one $\frac{3}{4}$ " FPT gravity drain fitting at the back of the cabinet (used for both ice making systems). A $\frac{1}{4}$ inch per foot fall is the minimum pitch for the drain tubing. There MUST be a vent at the highest point of the drain line, and the ideal drain receptacle is a trapped and vented floor drain.

Use only $\frac{3}{4}$ " rigid tubing.

Water Cooled Models: Install a separate drain tube for the condenser discharge water. There is one drain for both ice making systems. Connect it to the $\frac{1}{2}$ " FPT condenser drain connection at the back of the cabinet.

Storage Bin: Connect a separate gravity type drain tube, similar to the air cooled drain. Insulation of this drain line is recommended.

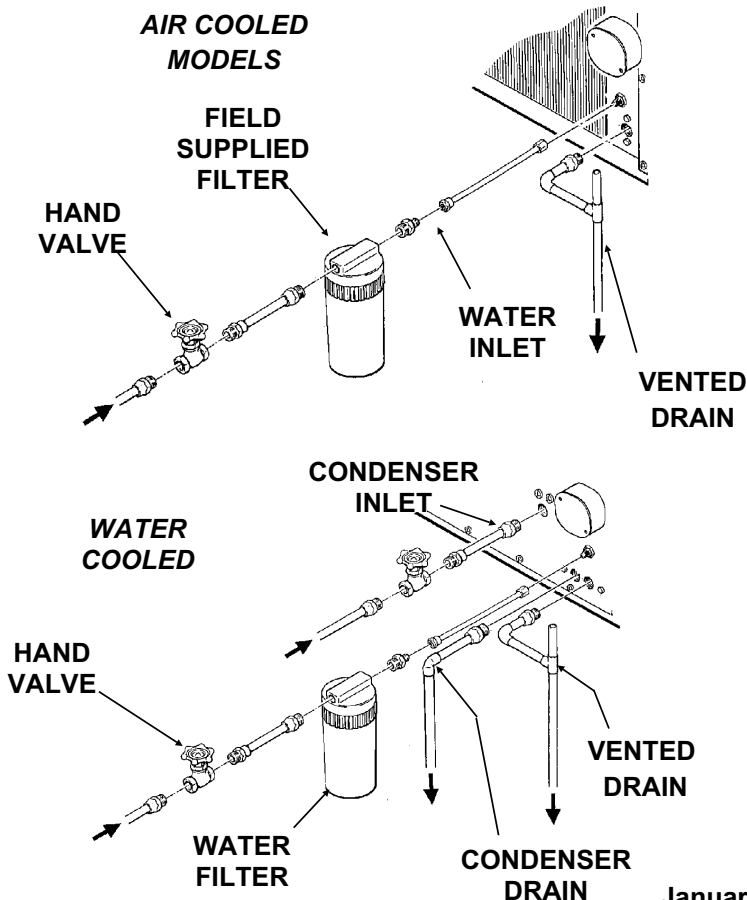

**COMPLETE PLUMBING INSTALLATION,
WATER COOLED**

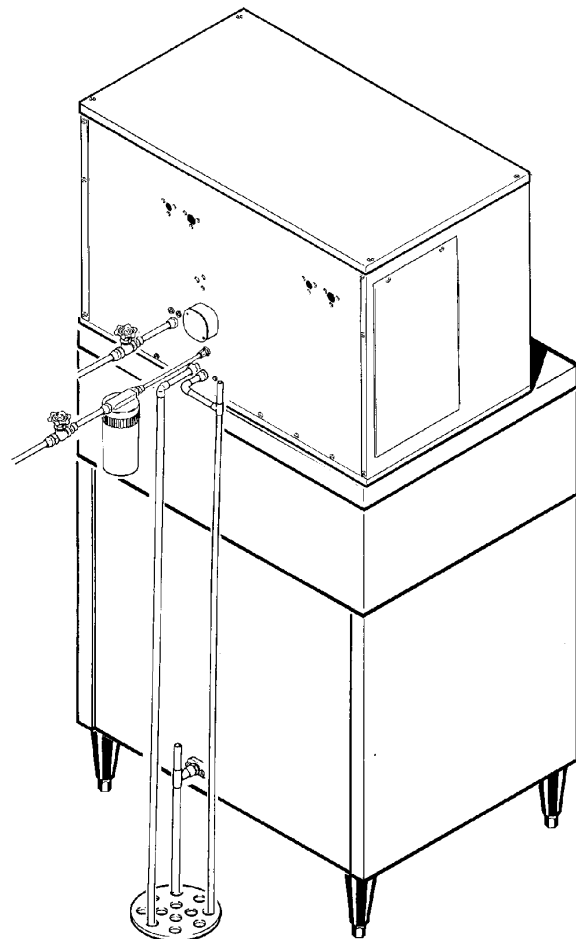

FOR THE ELECTRICIAN

CONFORM TO ALL APPLICABLE CODES

Connect electrical power to the leads in the junction box at the rear of the machine.

Check the nameplate (located on the back panel) for the voltage requirements, and for the minimum circuit ampacity. The machine requires a solid chassis to earth ground wire.

The ice machine must be connected to its own electrical circuit so that it is individually fused.

Voltage variation must remain within design limitations, even under starting conditions.

All external wiring must conform to national, state, and local electrical codes. The use of a licensed electrician is required to perform the electrical installation.

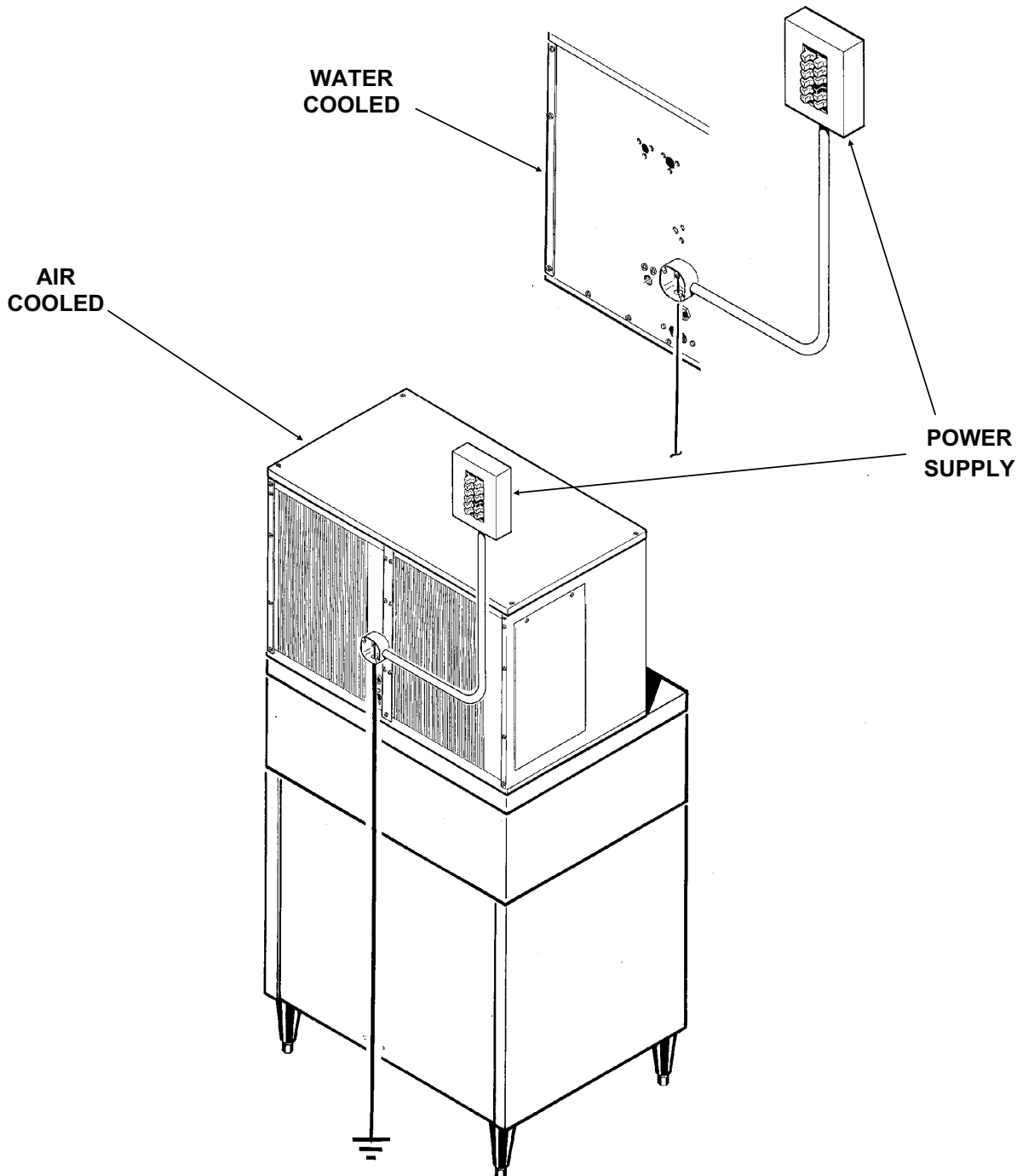

NME1854 & FME2404

FOR THE INSTALLER

Final Check List

- _____ 1. Is the ice system installed indoors in a location where the air and water temperatures are controlled, and where they do not exceed the design limitations?
- _____ 2. Is there an electrical service disconnect within sight of the installed machine?
Has the voltage been checked, and compared to nameplate requirements?
- _____ 3. Have all the plumbing connections been made and checked for leaks?
- _____ 4. Has the machine and bin been leveled?
- _____ 5. Is there a minimum of 6" clearance at the back of the machine for proper service access and air circulation?
- _____ 6. Is the water pressure a minimum of 20 psig?
- _____ 7. Has the machine been secured to the bin?
- _____ 8. Is there clearance above the top of the machine for service access?
- _____ 9. Is there a water shut off valve installed near the machine?
- _____ 10. Have all of the shipping blocks been removed?

START UP

Pre-Start Inspection

1. Remove the front and side service panels.
2. Check that any shipping blocks have been removed.
3. Inspect the interior of the machine for loose screws or wires. Check that no refrigerant lines are rubbing each other. Check that the fan blade turns freely (air cooled).
4. Check that the unit is installed correctly according to the final check list (page 8).

Start Up

The following procedure applies to each of the two separate ice making systems.

1. Go through the prestart inspection.

The air cooled discharge pressure will depend upon air and water temperatures, but should be between 200 psig and 280 psig.
2. Open the hand valve, observe that water enters the water reservoir, fills the tube from the reservoir to the evaporator, and then shuts off. Check for leaks.

The water cooled discharge pressure should be constant at about 245 psig.
3. Switch the master switch on.

The above numbers are for new, clean machines, you can expect to see some values higher, and some lower between different units.

The electrical start up sequence is automatic.
There will be a short (15 second) delay before the gear motor and compressor start.
4. Air cooled models will begin to discharge warm air out the back of the cabinet. Water cooled models will discharge warm water into the drain.
5. The unit will soon be making ice. If desired the low side pressure of each system may be checked: it should be 33 psig + or - 2 PSIG.

The suction line temperature at the compressor is normally very cold, nearly to the point of frost up to the compressor body, but not on it.
6. **THERE ARE NO ADJUSTMENTS TO MAKE**, so replace the panels.
7. Clean and/or sanitize the storage bin interior, wipe off the exterior with a clean, damp cloth.
8. Give the owner/user the service manual, instruct him/her in the operation of the unit, and make sure they know who to call for service.
9. Fill out the manufacturers registration and mail it to Scotsman.

NME1854 & FME2404

COMPONENT DESCRIPTION

Control Box: Contains the electrical controls that operate the machine.

High Pressure Cut Out Switch: An automatic reset switch sensing the high side refrigeration pressure. It is set to shut the machine off if the discharge pressure should ever exceed 450 PSIG.

Low Pressure Cut Out Switch: An automatic reset control that shuts off the ice machine when the low side pressure drops below a preset point, 15 PSIG.

Evaporator: A vertical stainless steel tube, refrigerated, and water filled. In it there is a stainless steel auger.

Compressor: The refrigerant vapor pump.

Reservoir: Float operated, it maintains the water level in the evaporator at a constant level, it also contains the water level sensor.

Water Level Sensor: Senses if there is water in the reservoir to make ice out of. Will shut the machine off if there is none.

Ice Discharge Chute: Directs the ice produced by the evaporator into the storage bin.

Ice Level Sensor: An electronic "eye", it senses the presence of ice in the bottom of the ice discharge chute. Operates to turn the ice machine on and off automatically as the level of ice in the bin changes.

Gear Motor: An oil filled, speed reduction gearbox, driving the auger.

Drain Tube: When uncapped and lowered, drains the evaporator.

Condenser: Air or water cooled, where the heat removed in ice making is discharged.

Expansion valve: The refrigerant metering device.

There are two of each of the above components in these machines.

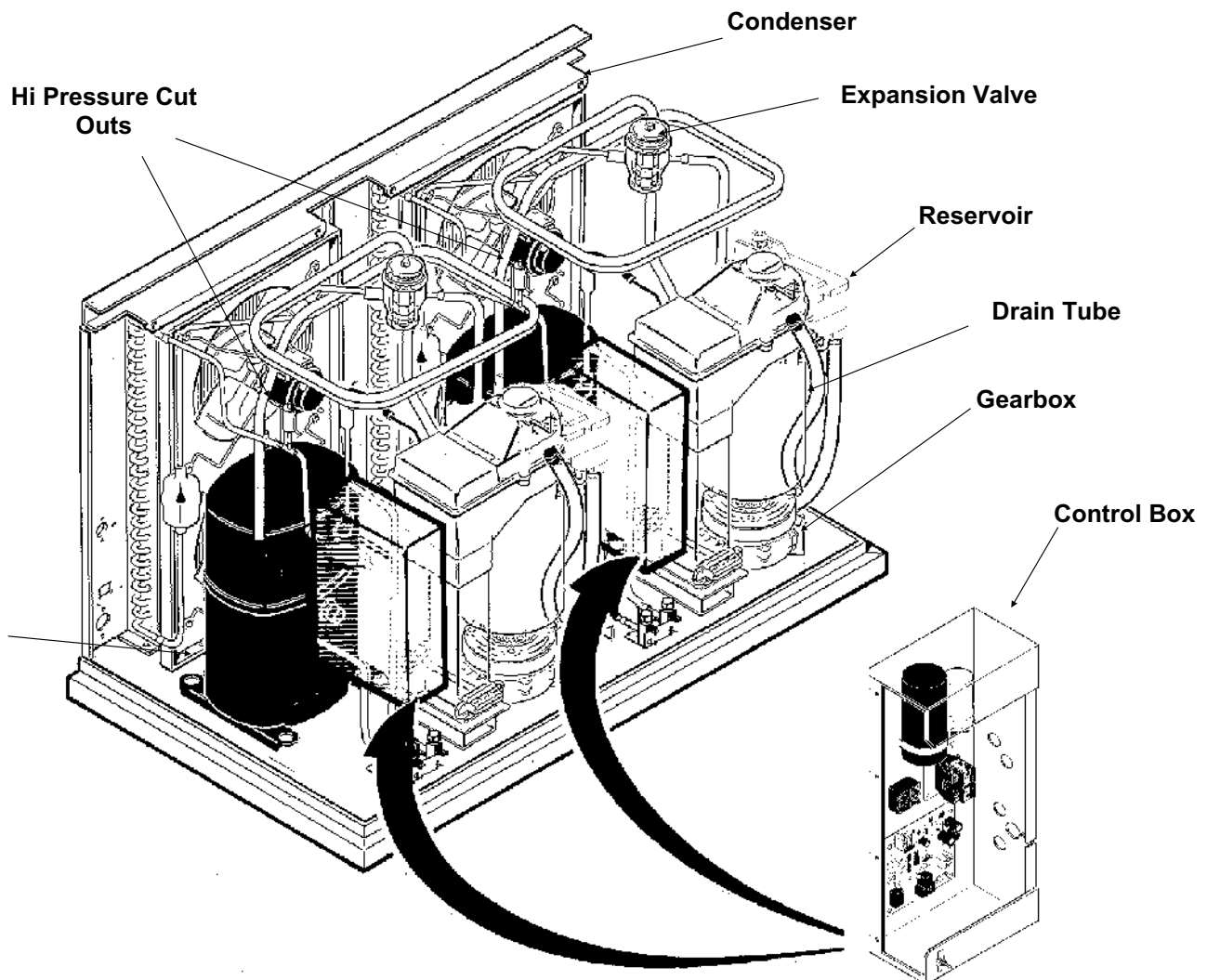

COMPONENT DESCRIPTION

Evaporator: A refrigerated vertical tube filled with water and containing a water seal and auger.

Auger: A solid stainless steel double spiral auger, it pushes the ice crystals up to the top of the evaporator.

Water Seal: A two part "face" seal, the top half rotating with the auger, the bottom half stationary, the sealing action being where the two seal "faces" meet.

Ice Sweep: A plastic cap with "fingers". It revolves with the auger to "sweep" the ice into the ice chute.

Breaker (Divider): Where the ice is compressed and much of the extra water is squeezed out of it before it is discharged into the bin.

Motor: A split phase motor that drives the gear reducer.

Thrust Bearing: As the ice is pushed up the evaporator, the auger is thrust down, and pressure from the auger thrust is taken up by this bearing.

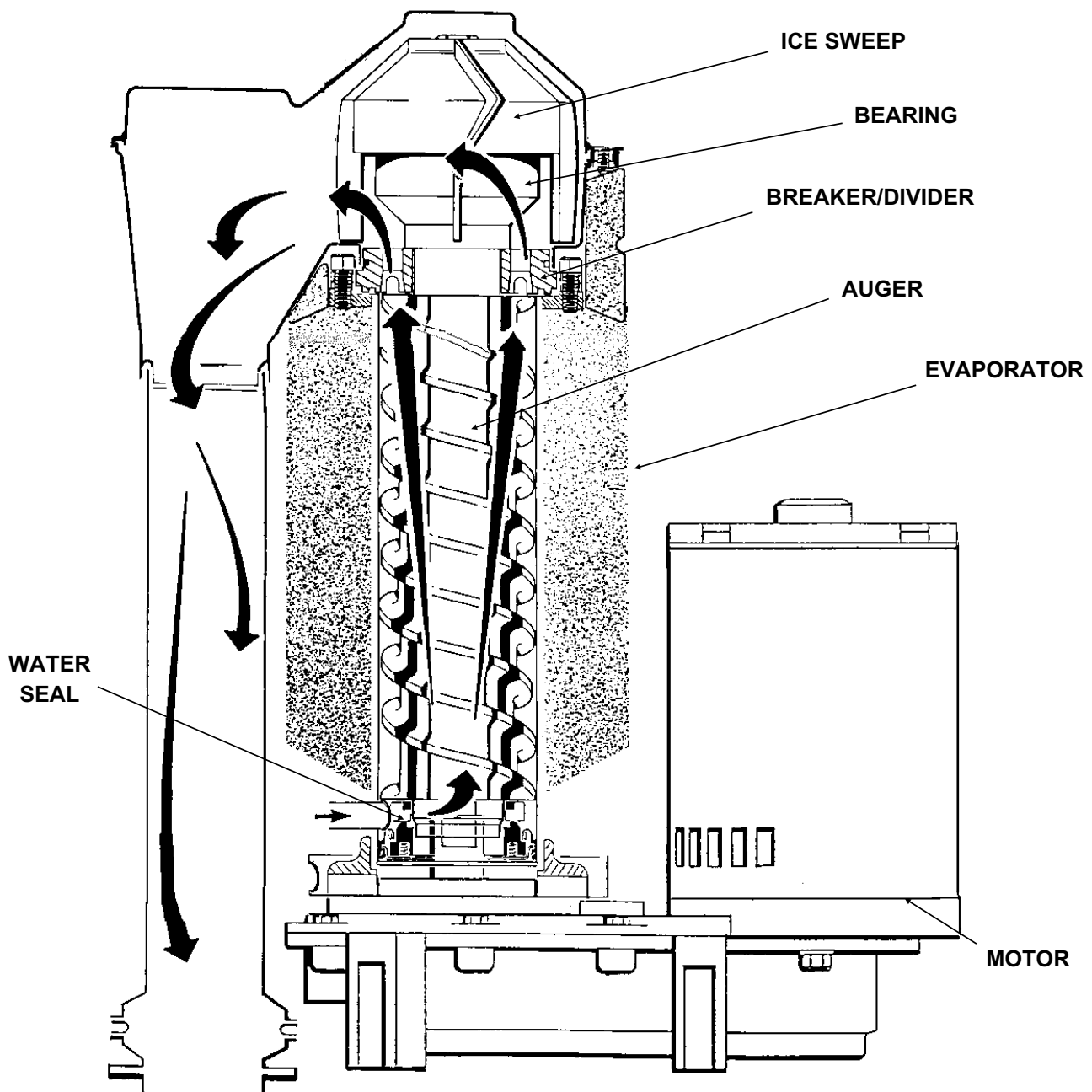

NME1854 & FME2404

COMPONENT DESCRIPTION: Control Box

Contactor: A definite purpose contactor connecting the compressor and the remote condenser fan motor to the power supply.

Circuit Board: Controlling the ice machine through sensors and relays. The sensors are for ice level and water level. The relays are for the gear motor (with a built in time delay to clear the evaporator of ice when the unit turns off) and for the compressor contactor.

Potential Relay: The compressor start relay.

On/Off Switch: Manual control for the machine.

Control Board

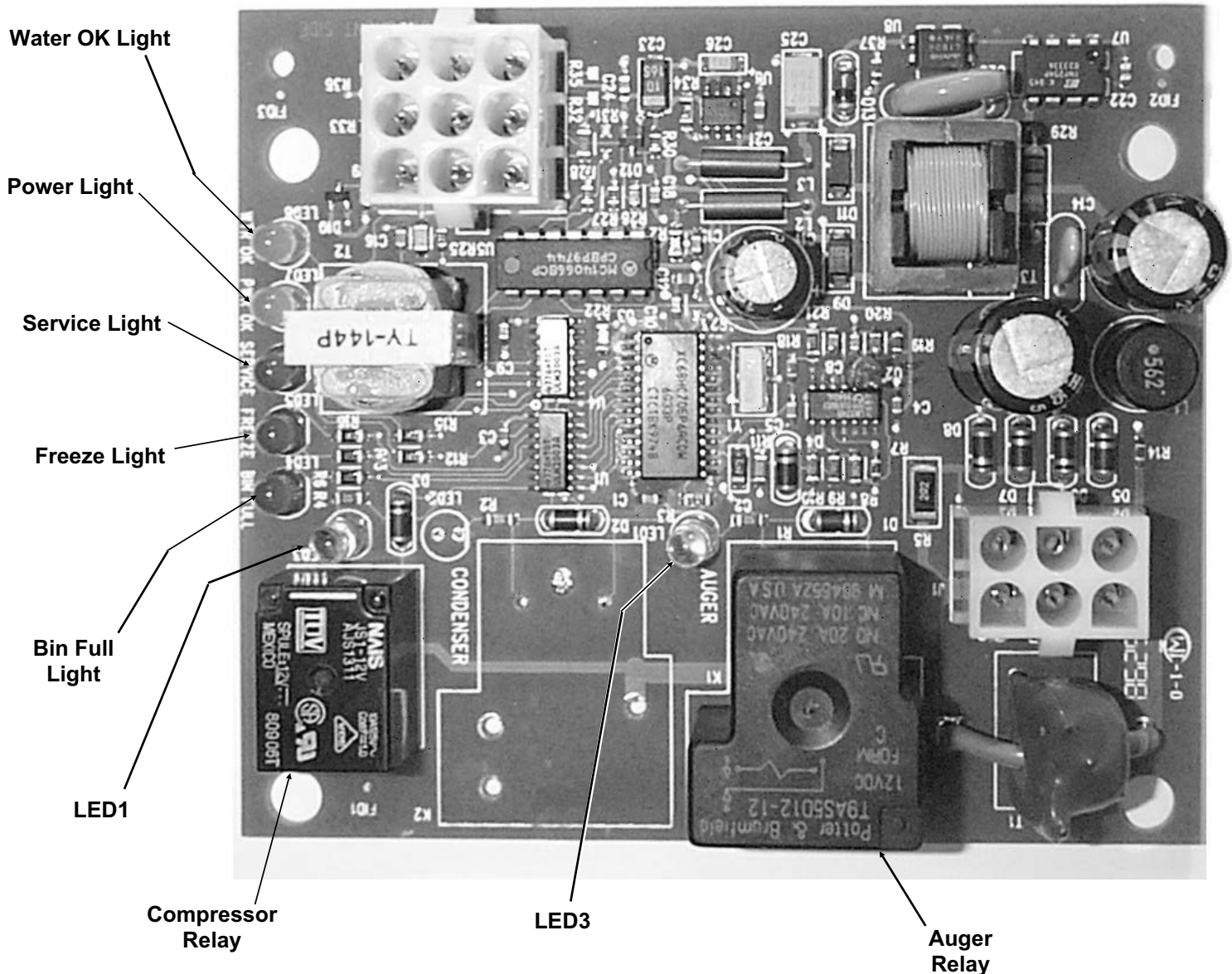

ELECTRICAL SEQUENCE

There are 7 indicator lights on the control board:

- **WTR-OK** (Water OK). *Green*. **Normal = Glowing. Glows when there is water in the reservoir.**
- **PWR-OK** (Power OK). *Green*. **Normal = Glowing. Glows when the control board has power and is functional.**
- **Service**. *Red*. Normally Off.
- **Freeze**. *Red*. Normally glowing when making ice.
- **Bin Full**. *Red*. Normally Off when making ice.
- **LED1**. *White*. Located next to the board's Compressor Relay. Normally Glowing when making ice.
- **LED3**. *White*. Located next to the board's Auger Motor Relay. Normally Glowing when making ice.

If the machine is switched off at the mode switch, but is otherwise ready to go, switching the mode switch to ON does the following:

- The PWR-OK light glows.
- If there is water in the reservoir the WTR-OK light glows.
- After 10 seconds the Freeze, LED1 and LED3 lights glow and the machine starts up.

Start Up:

- The compressor relay and auger motor relay become energized, connecting power to the windings of the auger motor and contactor coil.
- The contactor is energized, connecting power to the compressor, and the compressor starts.
- As ice is made it passes between the ice level sensors but because it is not a continuous stream it only interrupts the sensor's infrared beam momentarily. The bin full light remains off and the machine stays on until ice builds up in the bin and blocks the path between the sensors for 6 seconds or longer. When that occurs the bin full light glows and the machine shuts down.

Shut Down:

- The compressor relay opens, LED1 goes out.
- The compressor contactor opens
- The compressor stops
- The auger motor stays on for 1 more minute, clearing out ice in the evaporator, and then
- The auger motor relay opens, LED3 goes out and the auger motor stops.

The compressor will not restart until 2 minutes or more have passed after the last shut down.

If the path between the ice level sensors remains clear for more than 10 seconds the ice machine will restart.

Control Board Protection Devices

- When the water level in the reservoir falls below the water level sensor's tip, the WTR-OK light goes out and the machine shuts down. When water refills the reservoir the WTR-OK light glows and the machine starts up again.
- If the auger drive motor current becomes excessive the compressor and auger drive motor will be switched Off and the Service light will blink. The control board will restart the auger drive motor in 4 minutes. If during the first 60 seconds after restart the auger motor current stays within limits, the compressor is restarted and the machine returns to normal operation. If the auger motor's current is excessive within 60 seconds after the restart, the process will be repeated once more. If during that try the current is still excessive the machine shuts down and must be manually reset. The service light will then be glowing continuously.

To Reset: Disconnect and reconnect power to the ice machine.

Other Protection Devices:

- If the **high pressure** cut out switch opens the machine will stop immediately. It will automatically reset when the pressure falls below its cut in point.
- If the **low pressure** cut out switch opens the machine will stop immediately. It will automatically reset when the pressure rises above its cut in point.
- The **mode (on - off)** switch is the manual control for the complete machine, but it is not a service disconnect.

NME1854 & FME2404

OPERATION: Performance

Typical Low Side Pressure

- Air Cooled: 34 - 38 PSIG
- Water Cooled: 32 PSIG

Typical Discharge Pressure

- Air Cooled: 220 - 275 PSIG
- Water Cooled: 245 PSIG

Typical Compressor Amp Draw

- Single phase = 4.3
- Three phase = 2.8

Superheat

- 5 - 7 degrees

High Pressure Cut Out - automatic reset

- 450 PSIG

Low Pressure Cut Out - automatic reset

- 15 PSIG

Refrigerant Charge

- Air Cooled: 30 ounces R-404A
- Water Cooled: 24 ounces R-404A

OPERATION: Water

Water enters the machine through the 3/8" male flare at the rear of the cabinet, splits into two separate lines, flows to each water reservoir which it enters through the float valve. The water then goes out the bottom of the reservoir tanks to the bottom of each evaporator.

Reservoir overflow or evaporator condensation is routed to the drain.

Water cooled models have a separate water circuit for the cooling water: it enters the fitting at the rear, divides and goes to the two water regulating valves, then through each water cooled condenser, reconnects into one drain and down the drain.

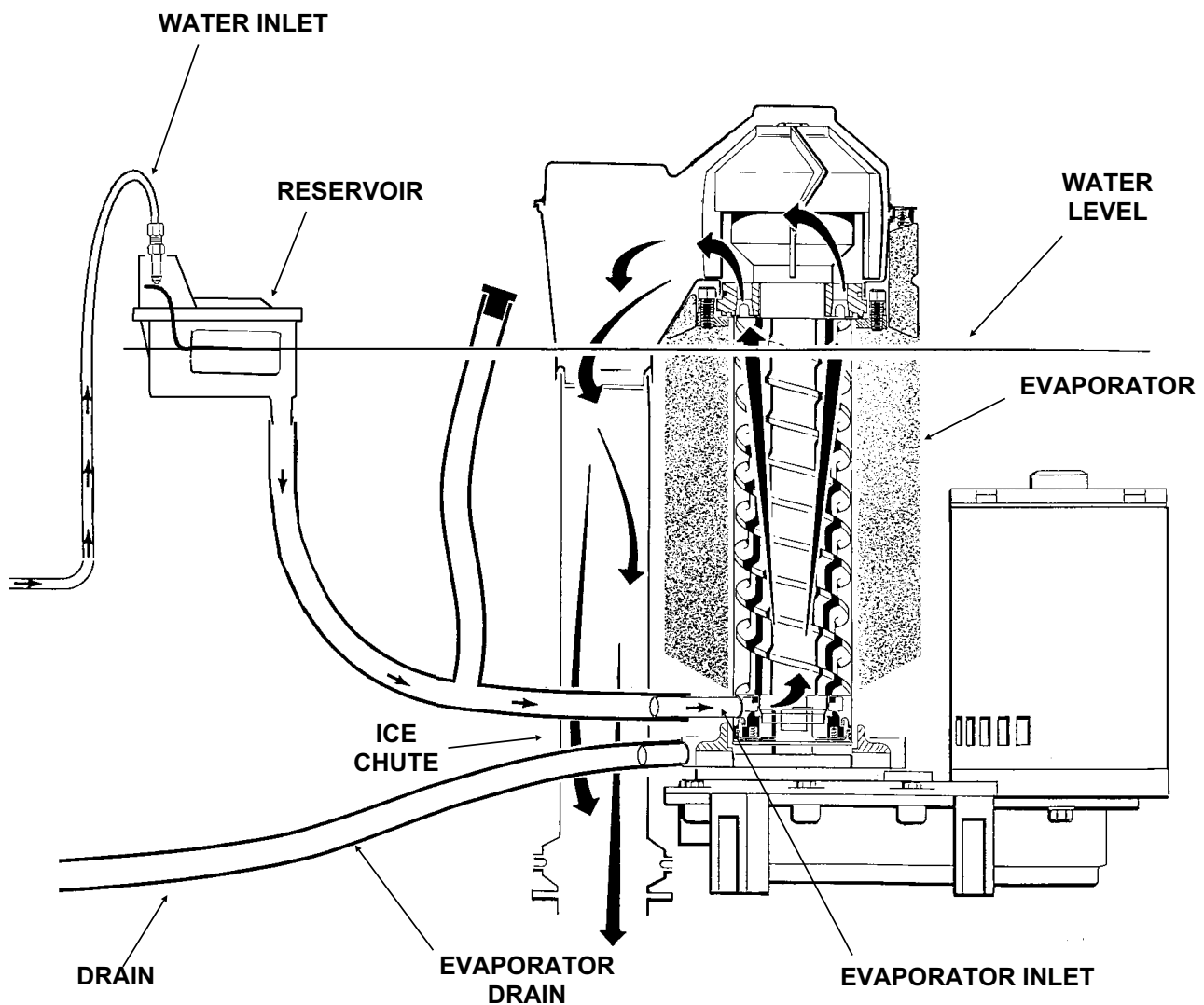

WATER SCHEMATIC

NME1854 & FME2404

OPERATION: Refrigeration

The following description applies to each of the two separate ice making systems.

Beginning at the compressor, refrigerant is compressed into a high temperature gas. The discharge line directs this gas to the condenser. At the condenser (air or water cooled) the gas is cooled by either air or water and it then condenses into a liquid. This high pressure liquid then goes through the liquid line to the expansion valve. The thermostatic expansion valve meters liquid refrigerant into the evaporator, the volume of liquid refrigerant depending upon the temperature of the evaporator; warmer evaporators get more refrigerant and colder evaporators get less.

At the evaporator, the refrigerant enters an area of relatively low pressure, where it can easily "boil off" or evaporate. As it evaporates, it absorbs heat from the evaporator and whatever is in contact with it (such as the water inside it). After the evaporator, the refrigerant, now a low pressure vapor, goes through the suction line back to the compressor, where the cycle is repeated.

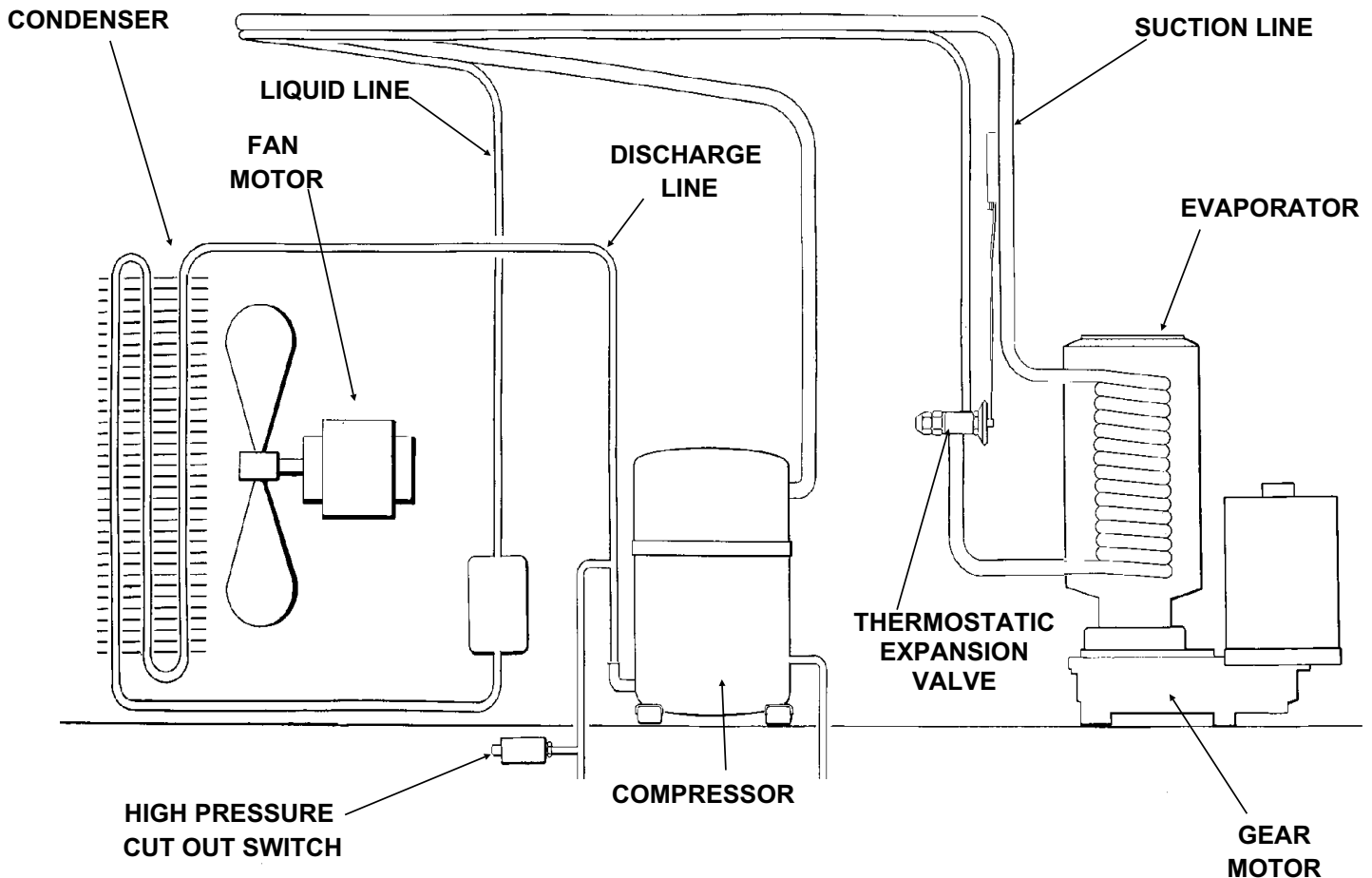

Refrigeration Schematic

CLEANING and SANITATION

To properly clean and maintain this product, these steps must be followed for **both** systems.

A Scotsman Ice System represents a sizable investment of time and money in any company's business. In order to receive the best return for that investment, it **MUST** receive periodic maintenance.

It is the **USER'S RESPONSIBILITY** to see that the unit is properly maintained. It is always preferable, and less costly in the long run, to avoid possible down time by keeping it clean; adjusting it as needed; and by replacing worn parts before they can cause failure. The following is a list of recommended maintenance that will help keep the machine running with a minimum of problems.

Maintenance and Cleaning should be scheduled at a minimum of twice per year.

ICE MAKING SYSTEM: In place cleaning

1. Check and clean any water treatment devices, if any are installed.
2. Remove screws and the front panel.
3. Move the ON-OFF switch to OFF.
4. Remove all the ice from the storage bin.
5. Remove the cover to the water reservoir and block the float up.
6. Drain the water reservoir and freezer assembly using the drain tube attached to the freezer water inlet. Return the drain tube to its normal upright position and replace the end cap.
7. Prepare the cleaning solution: Mix eight ounces of Scotsman Ice Machine Cleaner with three quarts of hot water. The water should be between 90-115 degrees F.

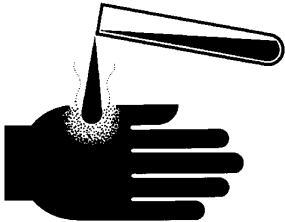
 WARNING	<p>Scotsman Ice Machine Cleaner contains acids.</p> <p>These compounds may cause burns.</p> <p>If swallowed, DO NOT induce vomiting. Give large amounts of water or milk. Call Physician immediately. In case of external contact, flush with water. Keep out of the reach of children.</p>
	

8. Slowly pour the cleaning solution into the water reservoir until it is full. Wait 15 minutes, then switch the master switch to ON.
9. As the ice machine begins to use water from the reservoir, continue to add more cleaning solution to maintain a full reservoir.
10. After all of the cleaning solution has been added to the reservoir, and the reservoir is nearly empty, switch the master switch to OFF.
11. After draining the reservoir, as in step 6, wash and rinse the water reservoir.

12. Go thru steps 13-19 to sanitize the ice machine water system.

13. Mix two gallons of sanitizer solution. Use an approved sanitizer.

A possible sanitizer solution may be obtained by mixing two gallons of warm (90-115°F.) potable water with 1 ounce of household bleach.

14. Slowly pour the sanitizer solution into the water reservoir until the float rises, then switch the master switch ON.

15. As the ice machine uses water from the reservoir, continue to pour the sanitizer solution into the reservoir.

16. After ½ of the sanitizer solution has been added to the reservoir, and the reservoir is nearly empty, switch the master switch OFF.

17. Drain the reservoir and thoroughly wash the interior of the reservoir and cover with sanitizer solution. Be sure the drain hose is upright and capped.

18. Remove the block from the float in the water reservoir.

19. Switch the master switch to ON

20. Continue ice making for at least 15 minutes, to flush out any cleaning solution.

DO NOT USE any ice produced from the cleaning solution. Be sure no ice remains in the bin.

21. Remove all ice from the storage bin.

22. Add warm water to the ice storage bin and thoroughly wash and rinse all surfaces within the bin.

23. Sanitize the bin interior by washing the interior of the bin with the balance of the sanitizer solution.

24. Switch the master switch ON.

25. Replace the front panel.

NME1854 & FME2404

SENSOR MAINTENANCE

*These steps must be followed for **both** systems.*

1. The bin control uses devices that sense light, therefore they must be kept clean enough so that they can “see”. At least twice a year, remove the bin control sensors from the base of the ice chute, and wipe the inside clean, as illustrated.

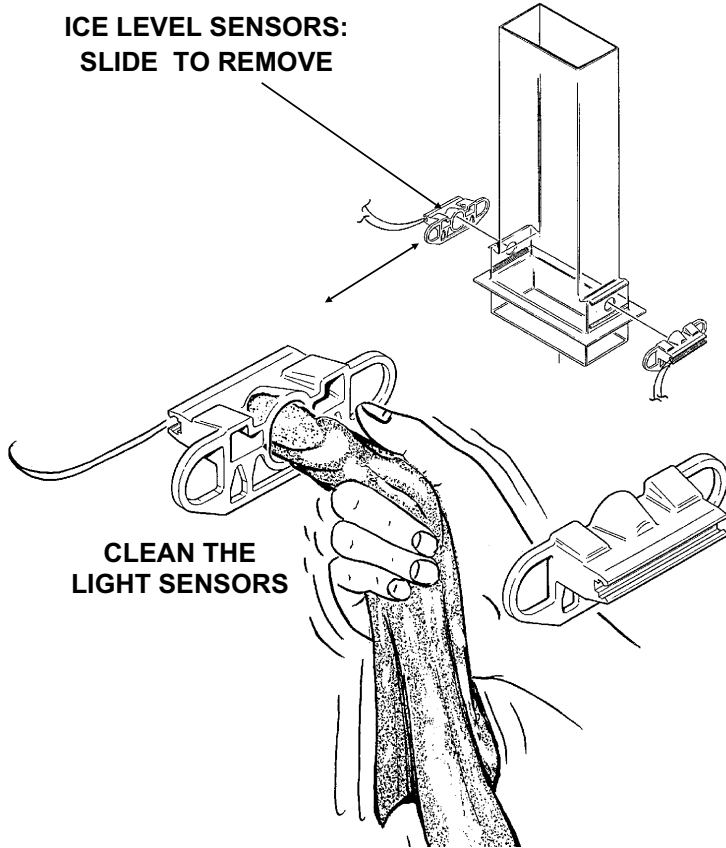

2. The ice machine senses water level by a probe located in the water reservoir. At least twice a year, the probe should be removed from the reservoir, and the tip wiped clean of mineral build-up.

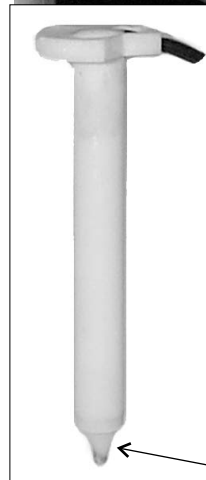
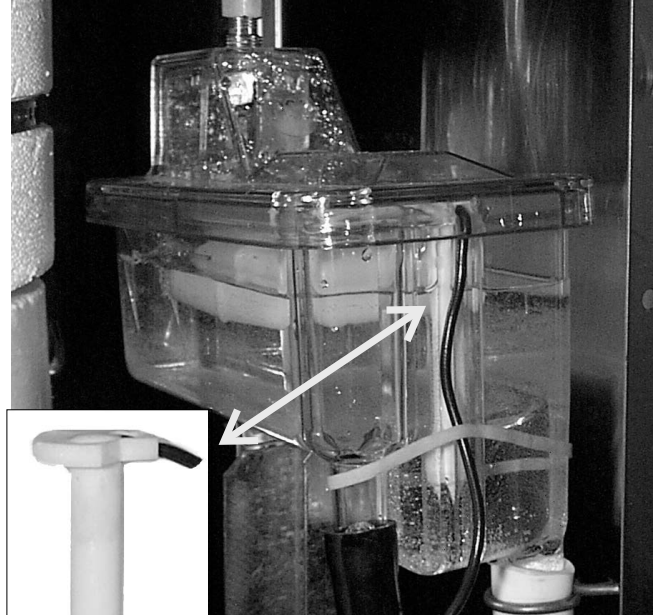

Clean the Probe's Tip with ice machine cleaner and a clean, soft cloth.

BEARING MAINTENANCE

Check each top evaporator bearing at least **two times per year**.

A. Check the bearing by:

- removing the ice chute cover

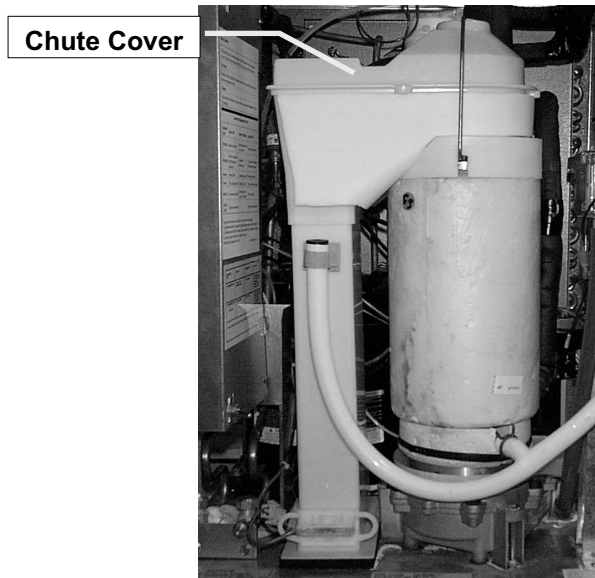

- unscrewing the ice sweep

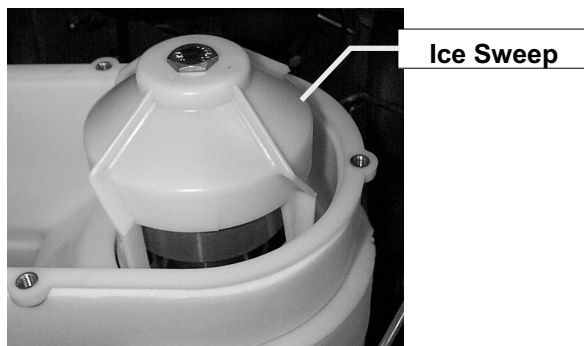

- removing the water shed & unscrewing the breaker cover.

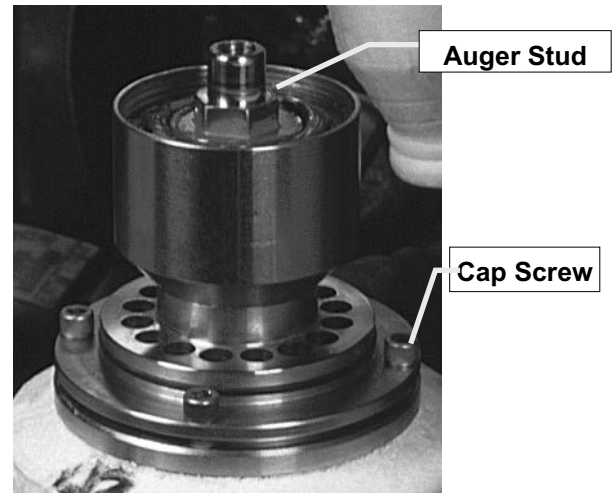
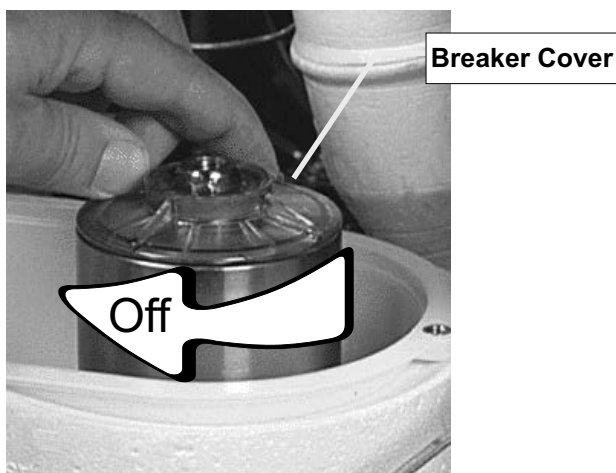

- unscrewing the auger stud

Inspect the bearing. There should be plenty of grease in sight. If grease is needed the bearing and breaker should be removed to check the action of the bearing. It should rotate smoothly.

To remove the breaker take out all four allen head cap screws and pull the breaker off the auger and evaporator.

If the bearing only needs grease, inject grease into the bearing using Scotsman grease needle pn 02-3559-01 and Scotsman bearing grease cartridge, pn A36808-001. Be sure to inject grease evenly and thoroughly.

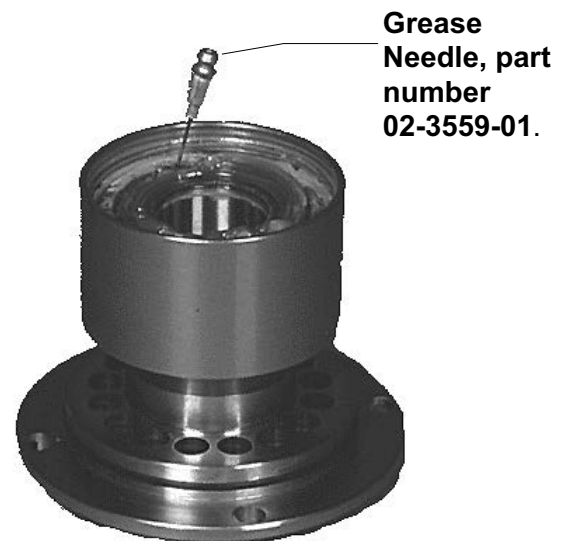

See Removal and Replacement section to replace bearing or seals.

Reverse to reassemble.

NME1854 & FME2404

AIR COOLED CONDENSER MAINTENANCE

Clean or replace the air filters regularly.

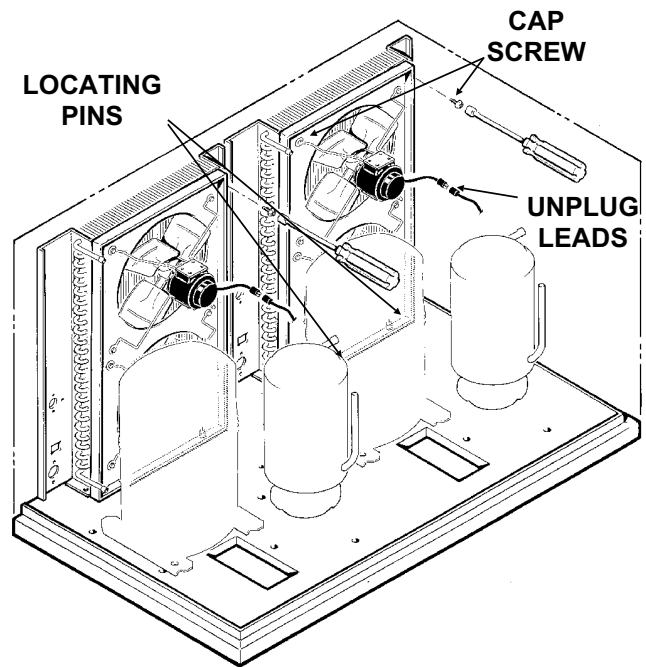
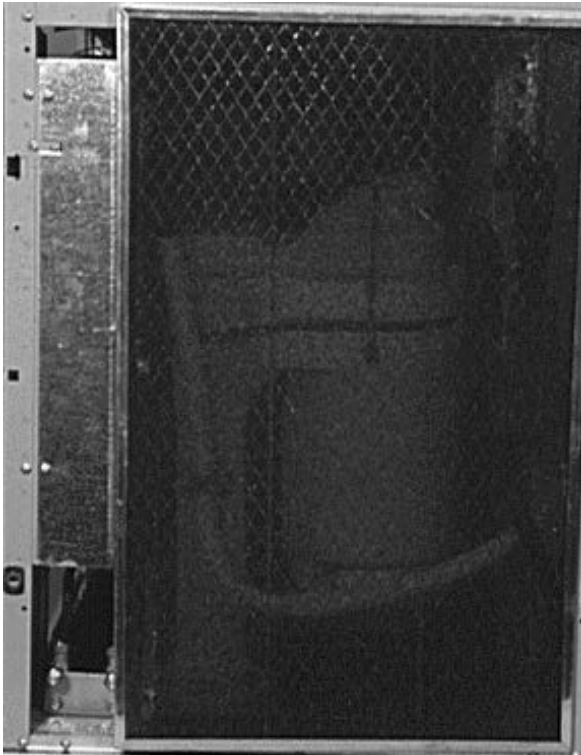

Clean each air cooled condenser. Use a vacuum cleaner or coil cleaner if needed. Do NOT use a wire brush.

	<p>⚠ WARNING</p> <p>Moving Parts Hazard.</p> <p>Disconnect electrical power before beginning.</p>
---	---

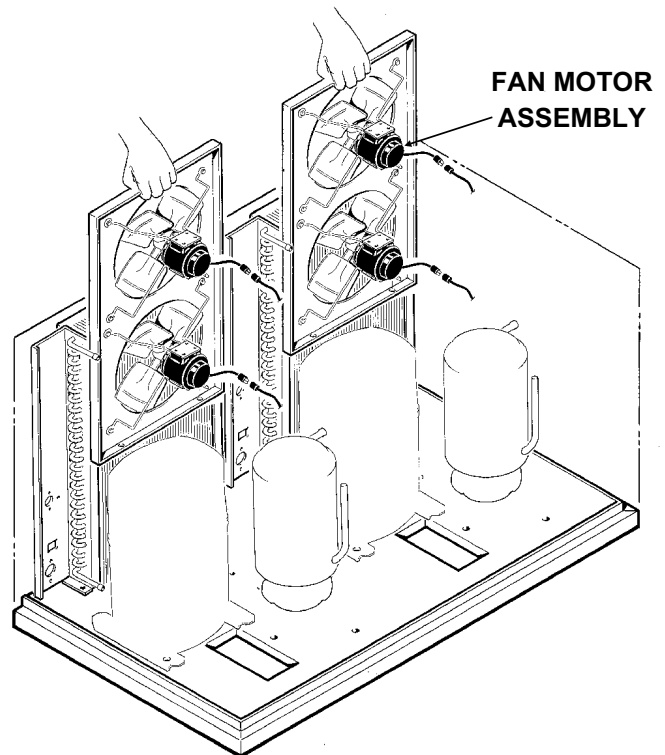

- A. Remove top panel.
- B. Remove two screws, and unplug the fan motors
- C. Pull fan motor assembly off of locating pins and out of the unit.
- D. Clean the condenser; reassemble by placing the fan motor assembly onto the locating pins, replacing the mounting screws, plugging the fan motors back in, and replacing the top panel. Reconnect power.

AUGER MAINTENANCE

In some areas the water supply to the ice machine will have a great deal of minerals in it, and that will result in an evaporator and auger becoming coated with these minerals, requiring a more frequent removal than twice per year. If in doubt about the condition of the evaporator and auger, the auger can be removed so the parts can be inspected.

Note: Water filters can filter out suspended solids, but not dissolved solids. "Soft" water may not be the complete answer. Check with a water treatment specialist regarding water treatment.

For more information on removal of these parts, see REMOVAL AND REPLACEMENT.

1. To remove the auger, remove the front and top panels.

	⚠ WARNING
	Moving Parts Hazard. Disconnect electrical power before beginning.

2. Push back bail clamp holding ice chute cover to ice chute, and remove cover.

3. Unscrew and remove ice sweep.

4. Loosen band clamp under ice chute, and remove ice chute from evaporator.

CAUTION
The auger has sharp edges, handle with care.

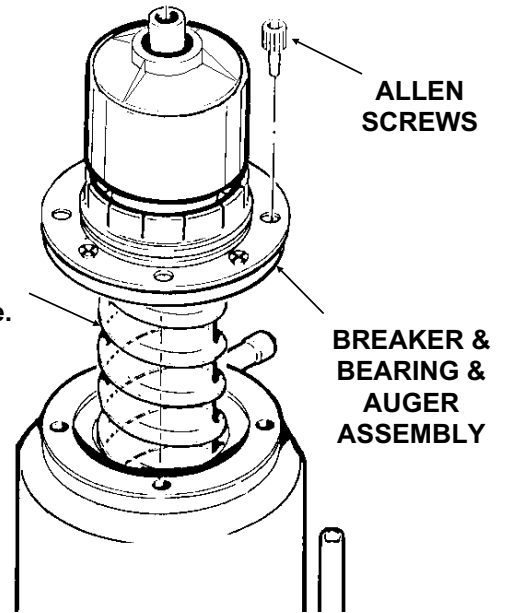

5. Remove 4 allen screws holding breaker to evaporator.

6. Drain the evaporator by pulling down and uncapping the evaporator drain tube.

7. Pull up to remove auger.

After the auger has been removed, allow the auger to dry: if the auger is not bright and shiny, it must be cleaned.

Clean the auger and evaporator as required. **DO NOT HONE THE EVAPORATOR.**

8. Replace the water seal.

9. Reverse to reassemble.

NME1854 & FME2404

SERVICE DIAGNOSIS:

No ice is made, nothing operates	Unit off due to no power	Restore Power
	Unit off due to master switch in OFF position.	Switch master switch to ON.
	Unit off due to low water level.	Check water supply, filter, strainer, float valve. Correct water supply.
	Unit off due to ice level sensors (photo-electric eyes) blocked.	Check/clean ice level sensors.
	Unit off due to scale on water level sensor.	Clean water level sensor.
	Unit off due to high pressure control open.	Check for water interruption (water cooled) or fan motor failure (air cooled).
	Auger motor hums but does not turn.	Auger can't turn. Circuit board has not yet shut unit down.
	Unit is shut down	Circuit board has shut ice machine down due to high auger motor amp draw. Check for cause of high amp draw, including bearings, gearmotor condition and scale on auger and in evaporator.
	Low pressure control open	Auger not turning due to: motor failure; auger relay failure on circuit board; or gears stripped. Check drive train.
		TXV restricted or not metering. Check bulb temperature.
		Lack of refrigerant. Check for leak.
		Check for a restricted system
	No power to circuit board.	Check harness
Circuit Board gear motor relay will not close	Check, replace board	
Water level or ice level sensor failed.	Check, replace sensor	
No ice, auger motor is turning	Compressor contactor coil is open	Check/replace contactor
	Compressor will not start	Check start capacitor.
		Check start relay
		Check compressor windings
Circuit board compressor relay will not close.	Check, replace board	
Unit makes ice, but very slowly.	High discharge pressure because of a dirty condenser	Clean the air filter and condenser.
	Low cap because auger & evaporator are coated with mineral scale	Clean the water system
	Low suction pressure due to low refrigerant charge	Locate leak. Recover refrigerant, repair leak, replace dryer, evacuate and weigh in the nameplate charge

SERVICE DIAGNOSIS

Symptom	Possible Cause	Probable Correction
Water Leak	Drain plugged up	Clean out drain
	Tubing cracked	Replace tubing
	Condensation on drain tubing	Insulate tubing
	Hose off	Reattach hose
	Reservoir cover off	Return cover to reservoir
	Reservoir cracked	Replace reservoir
	Evaporator water seal leaks	Check base of evaporator & drip pan. If the seal leaks, shut off the water, remove the auger, replace the water seal. Check gear motor for water infiltration.
Excessive water use	Water cooled model, water regulating valve not adjusted properly.	Adjust to 245 PSIG discharge pressure
	Reservoir float valve leaks thru	Replace float valve or seat
	Water cooled model, overcharged with refrigerant	Recover and weigh refrigerant. Weigh in correct charge.
	Water cooled model, condenser coated with minerals	Acid clean water cooled condenser.
Excessive ice meltage	Bin drain clogged	Clean out bin drain.
	Improper installation of drains, they are connected.	Drains must be separate.
	Poor fit between bin door and door frame	Adjust or replace
Machine makes too much noise	Evaporator coated internally with minerals	Clean with Scotsman Ice Machine Cleaner
	Motor bearings dry	Oil or replace motor

NME1854 & FME2404

CONTROL SYSTEM DIAGNOSTICS

The control system consists of:

- Control Board
- Water Sensor
- Ice Sensors
- High Pressure Cut Out
- Low Pressure Cut Out

If the unit is OFF, check the **control board**:

1. Is the Power OK light on? If not check power to the unit. If it has power, and the Power OK light is NOT on, check the high pressure and low pressure cut outs. If they are both closed, replace the board. If the Power OK light is ON, go to the next step.

2. Is the Water OK light on? If it is, go to the next step. If not, check the water level in the reservoir. If there is water in the reservoir, check that the water sensor is plugged in. To check the **water sensor**:

A. Unplug water sensor.

B. Pull water sensor from reservoir.

C. Place one ohmmeter lead on the sensor's plug and the other on the sensor's tip. The meter should show nearly zero resistance. If it reads infinite resistance, check the tip for corrosion. If it is clean and still reads open, replace the sensor.

OR connect a copper wire to the wire where the water sensor plugs into and place the other end in the water. The water OK light should go ON. If it does not, replace the control board.

3. **Ice sensor check.** Is the Bin Full light Off? If it is OFF and the Service light is Off, and the unit is not running, replace the control board.

If it is OFF and the auger motor is running but the compressor is not, check the compressor contactor coil.

If it is on, the ice sensors may be blocked. Remove them and check for mineral scale. Scotsman's test box can also be used to determine if the ice sensors or board are defective.

Using the tester:

A. Disconnect the ice sensors at the connection by the ice chute. Connect the LED and PHOTO TRANS wires to the control board's wires.

B. With the On - Off (mode) switch in either position, move the Bin Full switch on the tester to Bin Full - the tester's light will blink and after a few seconds the bin full light on the control board will come on. If not, replace the board.

Move the Bin switch on the tester to Bin Empty. The light on the tester will go out, and after a few seconds the Bin Full light on the board will go out. If master switch is ON, the unit should start.

4. **High pressure** cut out check.

Disconnect electrical power.

Pull the wires off the high pressure cut out.

Use an ohmmeter to determine if the switch is OPEN, If it is, check the discharge pressure. If the discharge pressure is less than 300 PSIG, replace the high pressure cut out.

If the high pressure cut out is open and the system has high discharge pressure, check for the cause.

5. **Low pressure** cut out check.

Disconnect electrical power.

Pull the wires off the low pressure cut out.

Use an ohmmeter to determine if the switch is OPEN, If it is, check the suction pressure. If the suction pressure is greater than 20 PSIG, replace the low pressure cut out.

If the low pressure cut out is open and the system has low suction pressure, check for the cause.

REMOVAL AND REPLACEMENT: Water Reservoir & Bin Controls

WATER RESERVOIR

1. Shut off water supply.
 2. Remove front panel.
 3. Remove reservoir cover.
 4. Disconnect water inlet tube from reservoir inlet fitting.
 5. To remove float valve, push in on "locking tab" as shown and pull valve up.
- Note: The plunger/seat is available as a separate part.
6. To remove reservoir, pull up and remove water sensor.
 7. Disconnect water outlet tubes.
 8. Remove the two screws holding reservoir to bracket.
 9. Remove reservoir from machine.
 10. Reverse steps 1-9 to reassemble.

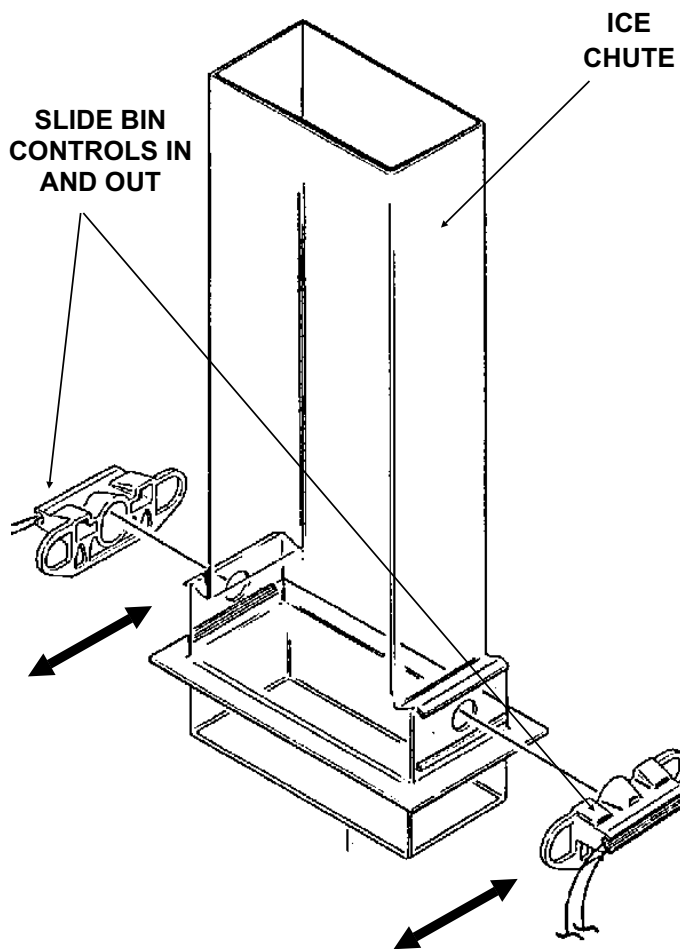
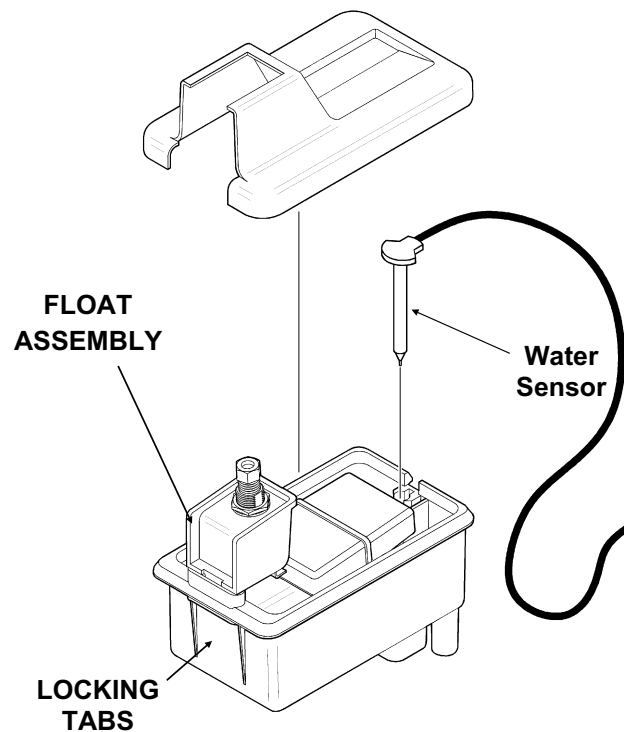

BIN CONTROLS (Ice Level Sensors)

1. Disconnect electrical power.
2. Remove the front panel.
3. Remove the control box cover.
4. Locate the ice chute. At the base of the chute in front of and behind it are two plastic bin control mounts.
5. Slide each bin control to the left, and in the control box, disconnect the bin control at the circuit board.
6. Reverse to reassemble, be certain that the bin controls are aligned so that the ice level sensors are visible (centered) through the holes in the ice chute.

NME1854 & FME2404

REMOVAL AND REPLACEMENT: Bearing And Breaker

Note: Removal of the auger, water seal, evaporator and gear motor must begin at the top of the assembly.

To Remove the Breaker Bearing Assembly:

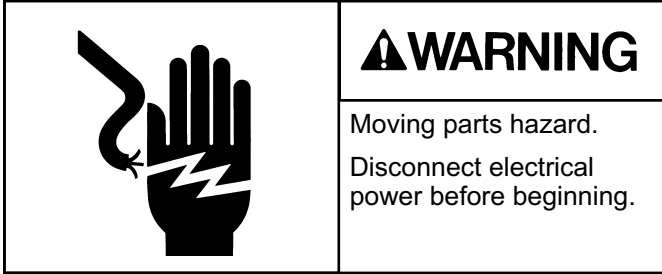

1. Remove panels and disconnect electrical power.
2. Push bail clamp back and remove ice chute cover.
3. Unscrew and remove ice sweep.
4. Lift up and remove ice chute.
5. The breaker may be removed from the auger and evaporator without disturbing the auger.
 - a. Unscrew breaker cover from breaker (left hand threads)
 - b. Unscrew auger stud from top of auger.
 - c. Unscrew 4 allen head cap screws holding breaker to evaporator.

- d. Lift up, and remove breaker/bearing assembly from auger & evaporator.
6. Service the bearing. Check for rust, rough spots and damage.
 - a. The bearing is pressed into the breaker, to remove the bearing and replace it an arbor press is needed.

- b. Replace lower seals before installing new bearing in breaker.

Note: seals must be pressed in with a tool pushing against the outer edge only, they will not install by hand.

Replace parts as required. Re-grease bearing with Scotsman part no. **A36808-001** bearing grease. Replace top seal, and check the o-rings, replace if cut or torn.

7. Reverse to reassemble: specific tools and materials are required to install properly.

- a. Add food grade grease such as Scotsman part number 19-0569-01 to the seal area before installing on the auger.
- b. Check the seal to shaft areas for cuts, or rough spots: none are permitted.

Step 5-a

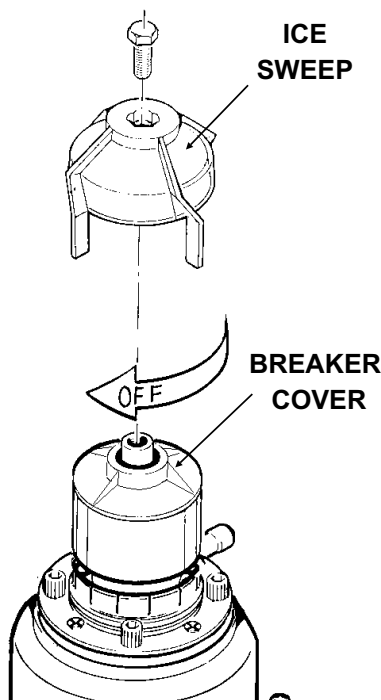

Step 5-b

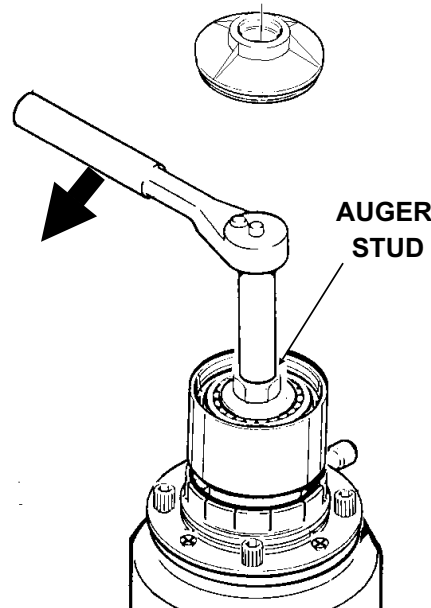

Step 5-c and Step 6

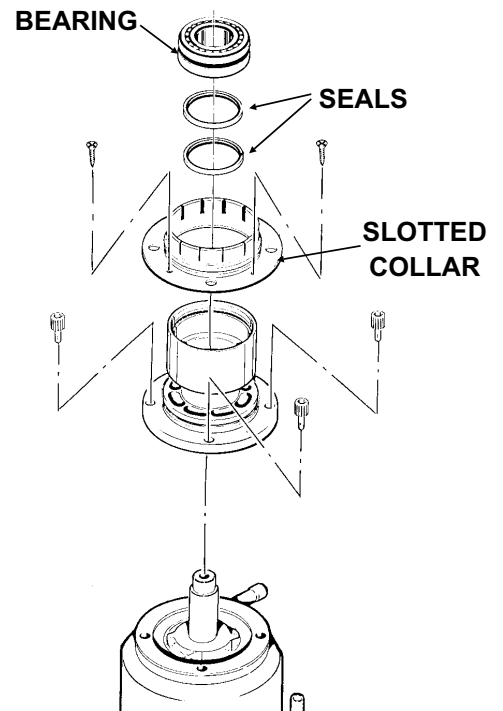

REMOVAL AND REPLACEMENT: Auger

To Remove the Auger:

Turn off the water to the machine, and unclip the evaporator drain hose, pull it down and drain the evaporator into the bin or a container.

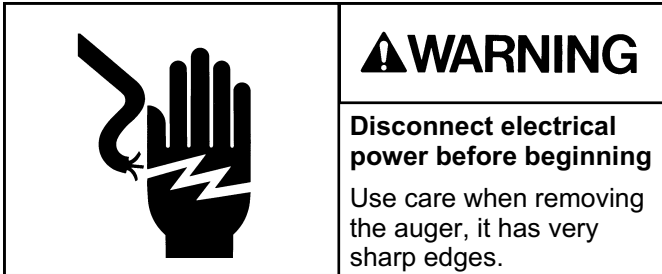

1. The top panel must be removed.
2. Remove ice chute cover.
3. Unscrew ice sweep.
4. Remove ice chute body.
5. The auger and breaker/bearing may now be removed as an assembly.
 - a. Unscrew 4 allen head cap screws holding breaker to evaporator.
 - b. Lift up on

e. If the auger is stuck use a slide hammer type puller to pull on the auger at the threaded hole. The size of that hole is 5/8"-18.

Inspect the auger, the critical areas of the auger are:

1. The auger body. It should be clean and shining. Sometimes an auger will appear clean when wet, but after it is dry it will be seen to be stained. Scrub the auger with ice machine cleaner and hot water.

CAUTION

Ice machine cleaner is an acid. Handle it with extreme care, keep out of the reach of children.

2. The water seal area. Because the auger has been removed, the water seal will have to be replaced. Remove the water seal top half from the auger, and inspect the auger for minerals clean as required.

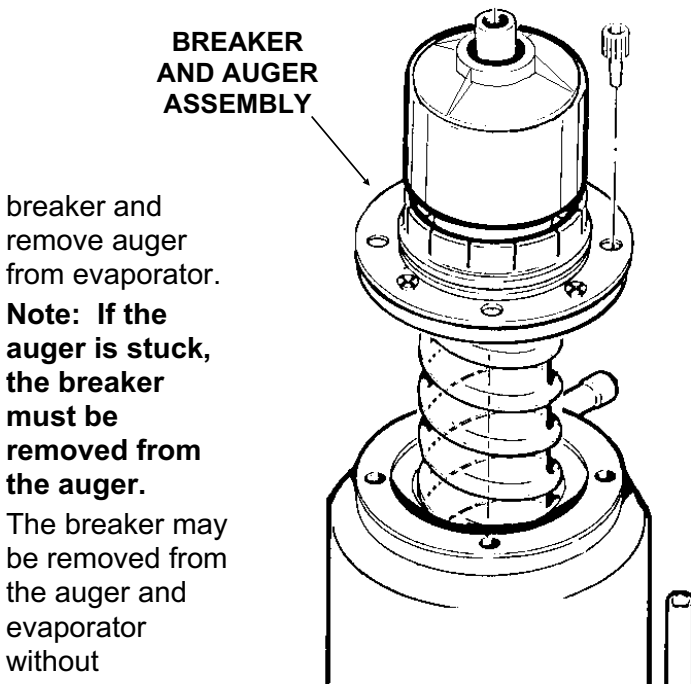

breaker and remove auger from evaporator.

Note: If the auger is stuck, the breaker must be removed from the auger.

The breaker may be removed from the auger and evaporator without disturbing the auger.

- a. Unscrew breaker cover from breaker (left hand threads)
- b. Unscrew auger stud from top of auger.
- c. Unscrew 4 allen head cap screws holding breaker to evaporator.
- d. Lift up & remove breaker from evaporator.

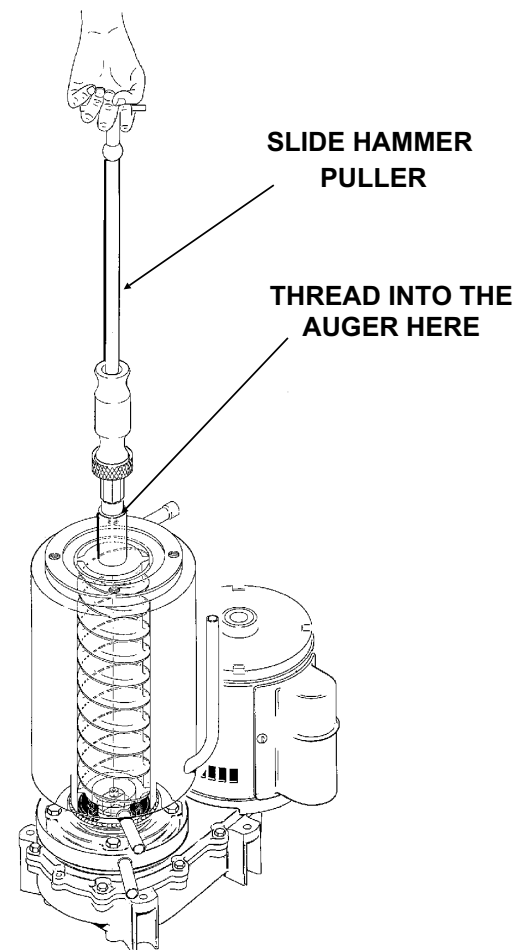

NME1854 & FME2404

REMOVAL AND REPLACEMENT: Water Seal

To Remove the Water Seal:

(Assuming all steps to remove the auger have been performed.)

1. The gear motor/evaporator assembly will have to be exposed.
2. Remove the 4 hex head cap screws holding the evaporator to the gear motor assembly. Lift the evaporator up and off of the gear motor.
3. Remove the snap ring or wire retainer from the groove under the water seal.
4. Pull or drive out the lower half of the water seal.

To Replace the Water Seal:

1. Lubricate the water seal with water, and push the water seal into the bottom of the evaporator slightly past the groove for the snap ring.
2. Replace the snap ring and pull the water seal down against it.
3. The part of the water seal that rotates with the auger must also be replaced. Remove the old part from the auger and clean the mounting area.
4. Place a small bead of food grade silastic sealant (such as 732 RTV or Scotsman part number 19-0529-01) on the area of the auger where the water seal is to be mounted.

REMOVAL OF THE WATER SEAL

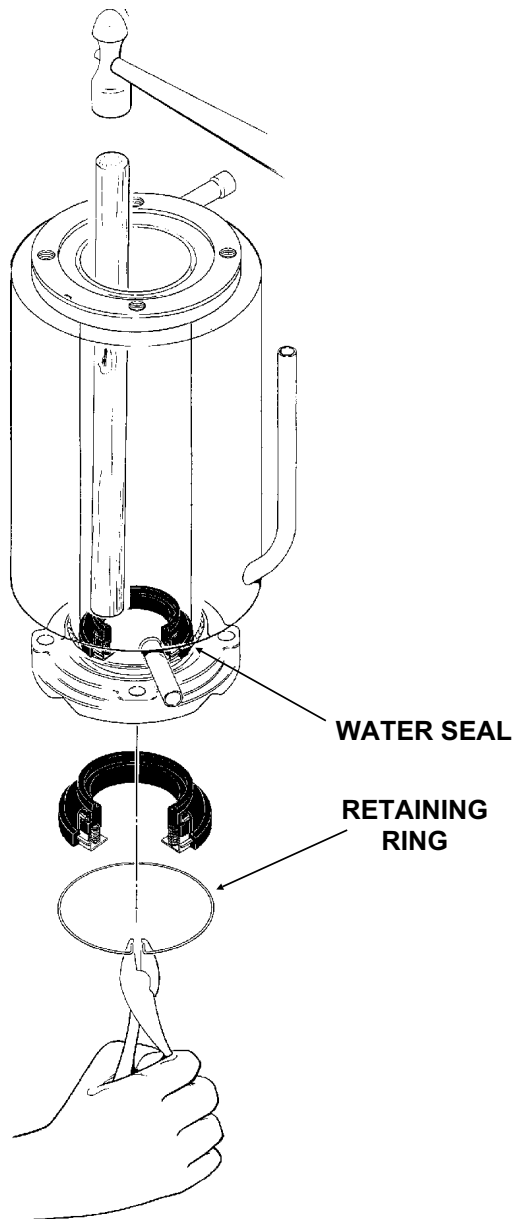

REPLACING THE WATER SEAL

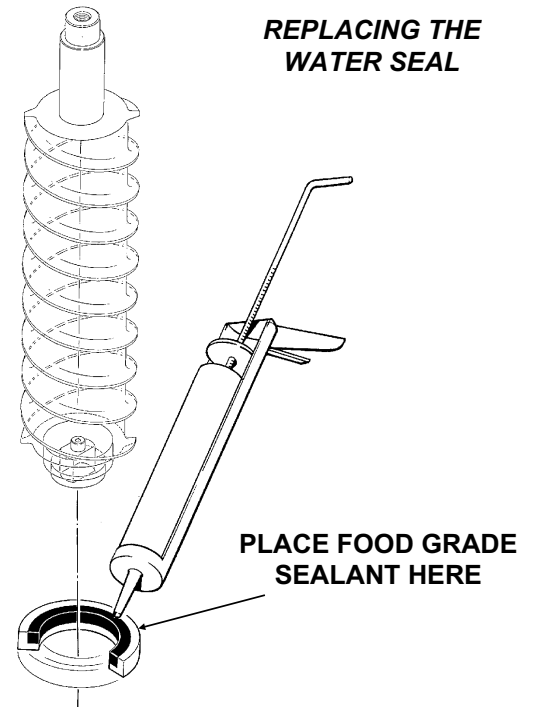

5. Carefully push the water seal (rubber side against the auger shoulder and the silastic).

CAUTION

Do not get any silastic onto the face of the seal.

6. Allow the auger and seal to air dry until the silastic is dry on the surface.
7. If the original water seal was leaking, it would be a good idea to inspect the interior of the gear motor.

REMOVAL AND REPLACEMENT: Evaporator

To Replace the Evaporator:

(Assuming all the steps for removal of the thrust bearing, breaker, auger, and water seal have been performed.)

1. Recover the refrigerant from the ice machine.
2. Unswheat the refrigerant connections:
 - a) At the thermostatic expansion valve outlet.

— — — — — CAUTION — — — — —

Heat sink the TXV body when unswearing or resweating the adjacent tubing.

- b) At the suction line at the joint about 3" from the evaporator.

3. Remove the evaporator.
4. Unswheat the drier from the liquid line.
5. After installing a new water seal in the new evaporator (see "To Replace the Water Seal") sweat in the new evaporator at the old tubing connections.
6. Install a new drier in the liquid line.
7. Evacuate the system until dehydrated (300 microns), then weigh in the nameplate charge. Check for leaks.
8. Install auger, breaker, breaker bearing assembly, and ice discharge chute in reverse order of disassembly.

To Reassemble the Evaporator and Auger

1. After the gear motor has been inspected, fasten the evaporator to the gear motor. Torque the bolts to 110 inch pounds.
2. Lower the auger into the evaporator barrel, slightly turning it to match up with the drive end. Do Not Drop Into the Evaporator.
3. Complete the reassembly by reversing the disassembly for the breaker & thrust bearing assembly.

FME Evaporator Shown, NME Similar

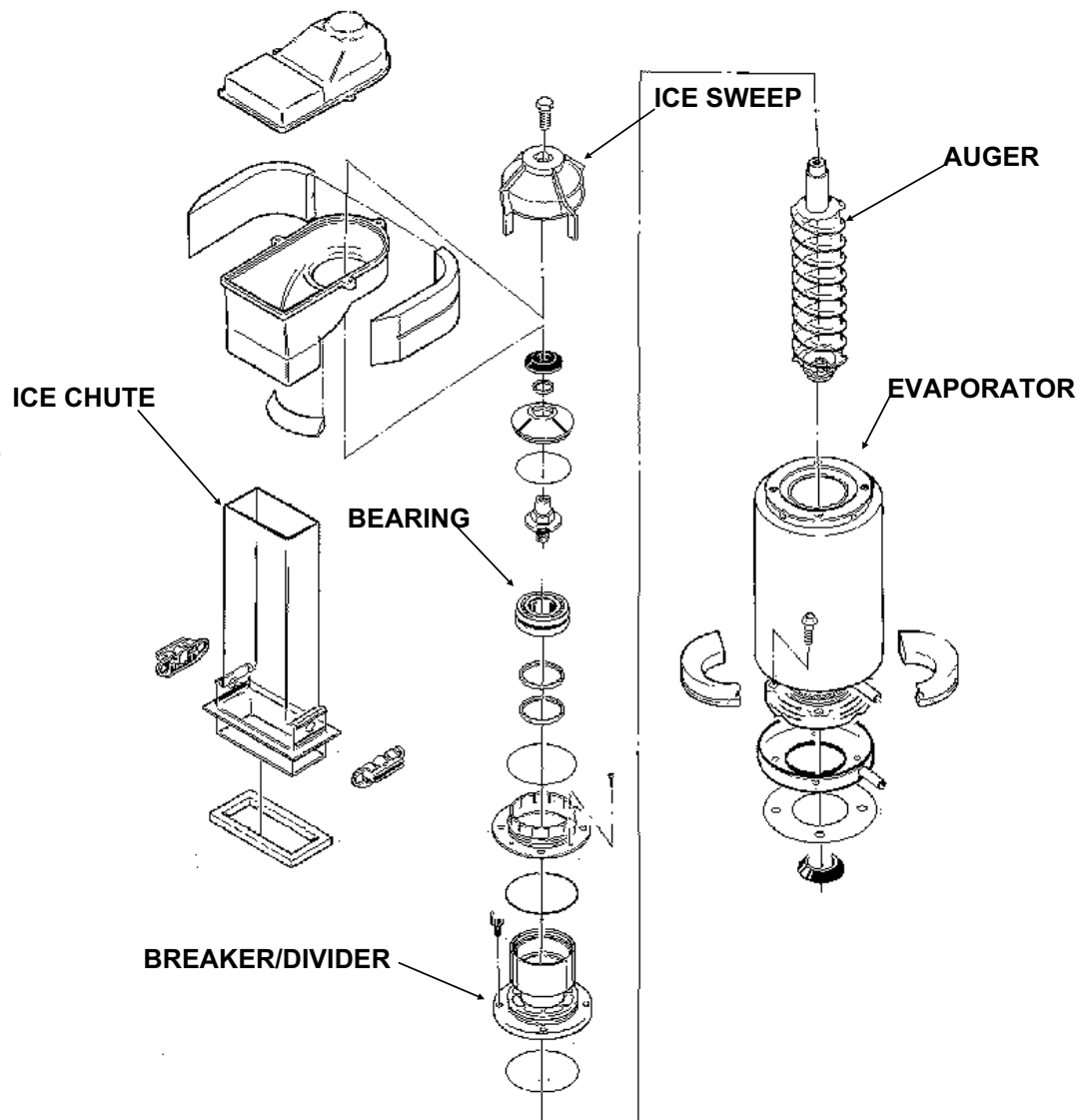

NME1854 & FME2404

REMOVAL AND REPLACEMENT: Gearmotor

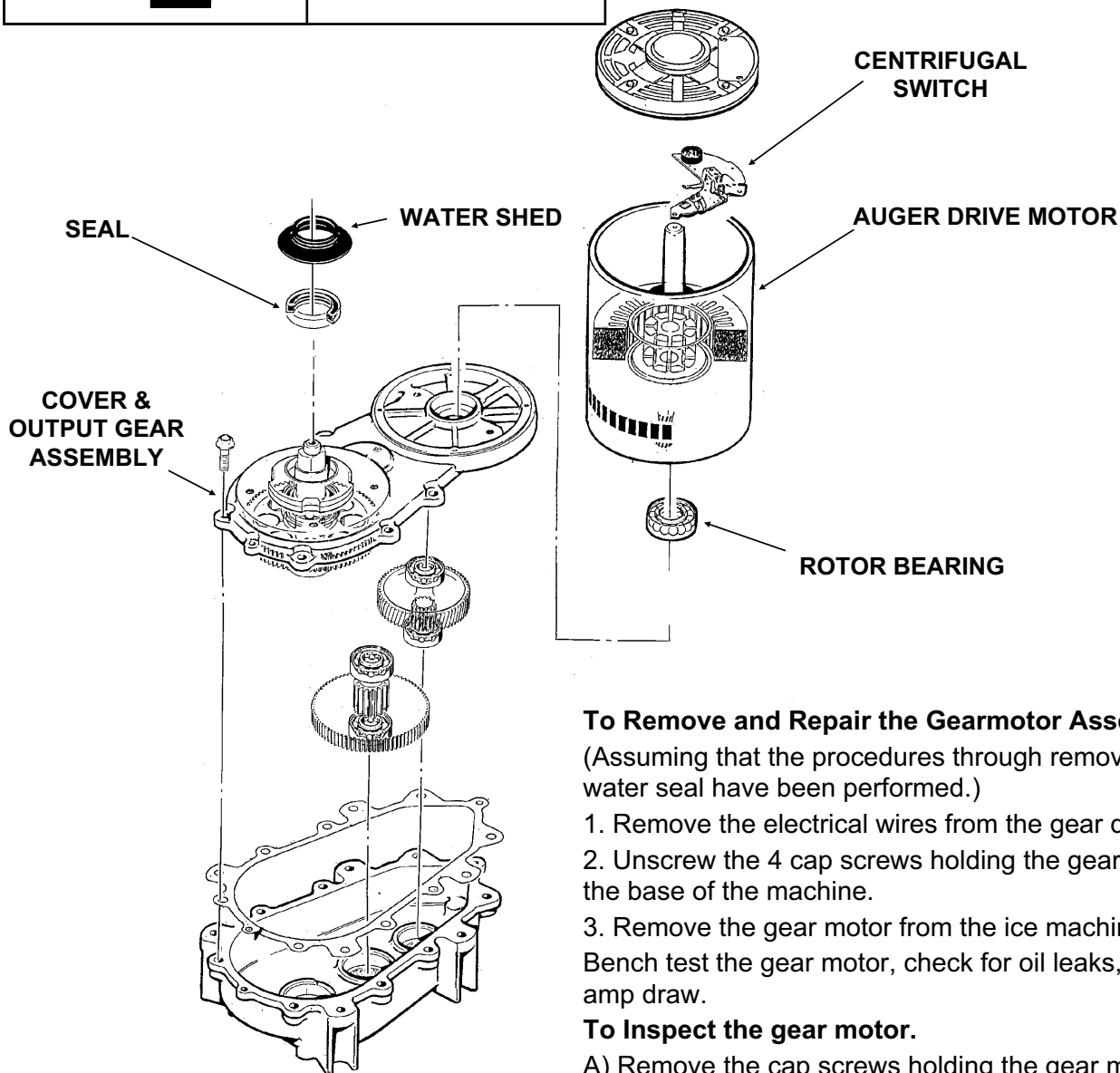
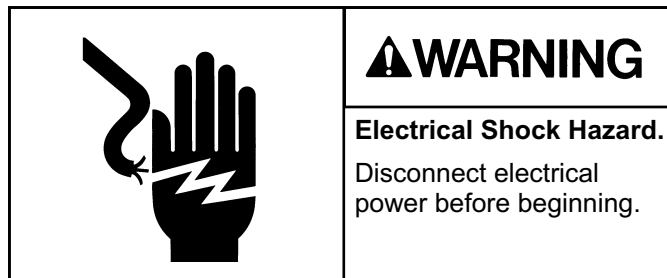

Note: There are two gear motors in each unit.

To Remove and Repair the Gearmotor Assembly:

(Assuming that the procedures through removal of the water seal have been performed.)

1. Remove the electrical wires from the gear drive motor.
 2. Unscrew the 4 cap screws holding the gear motor to the base of the machine.
 3. Remove the gear motor from the ice machine.
- Bench test the gear motor, check for oil leaks, noise, and amp draw.

To Inspect the gear motor.

- A) Remove the cap screws holding the gear motor case halves together and pry the two cases apart.
- B) To lift off the cover, lift up until you can feel internal contact, then pull the cover towards the output gear end, and then lift the cover (with drive motor attached) up and away from the gear motor case.

Note: The gearcase cover, output gear, bearings and output shaft are a pressed together assembly.

REMOVAL AND REPLACEMENT: Fans

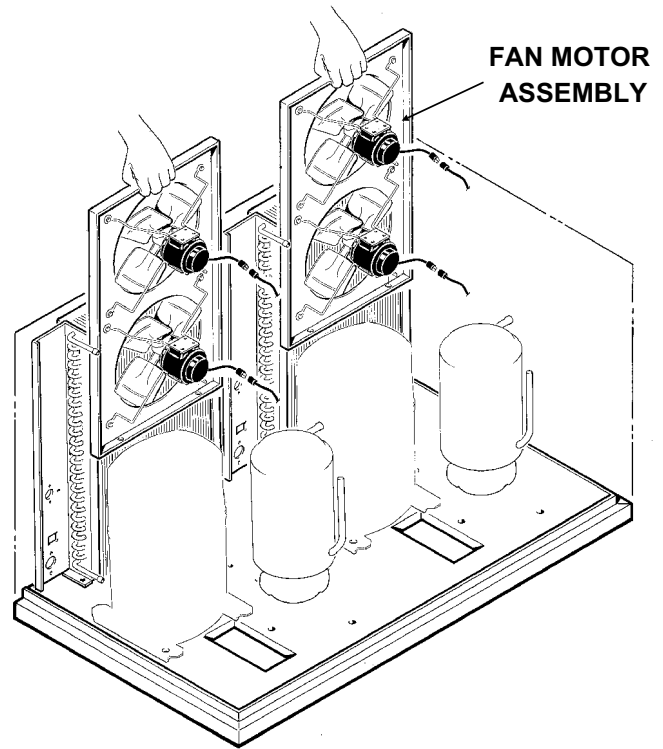
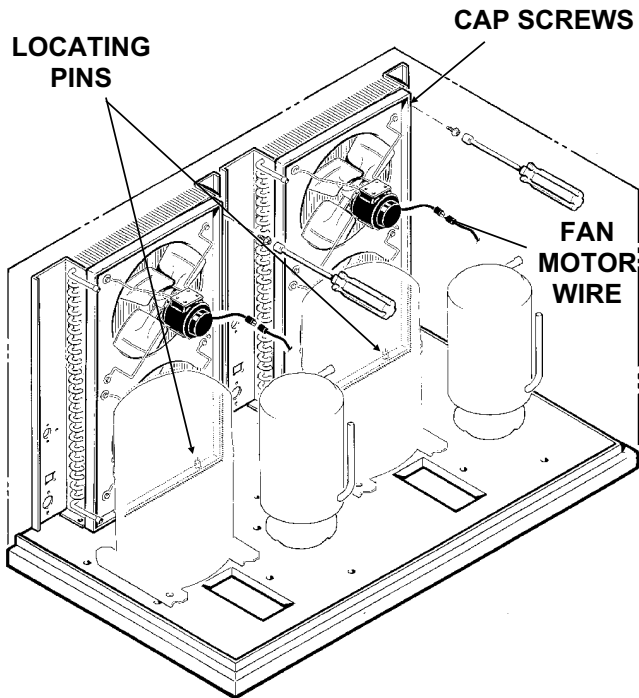
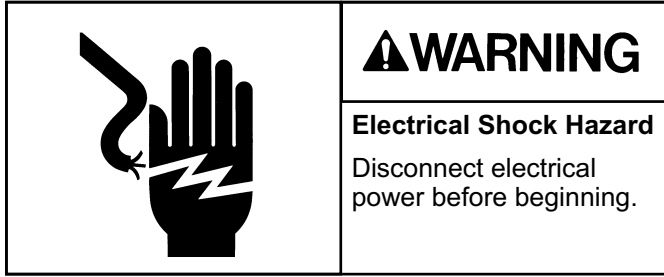

Removing Condenser Fan Motor Assembly

1. Remove the top panel.
2. Unplug the two fan motor wire leads from the fan motors.
3. Remove two hex head bolts from top end of fan motor assembly, (see the illustration).
4. Lift up, and pull out the fan motor assembly.
5. Repair as needed.
6. To reassemble: Place the fan motor assembly lower flange holes over the two allen head cap screws in the base, and reinstall the hex head bolts at the top of the assembly. Plug the fan motors back in, and replace the top panel.

NME1854 & FME2404

REFRIGERATION SERVICE

General: This ice machine uses R-404A refrigerant and polyolester oil. Do NOT use mineral oil in this refrigeration system.

- When the system is serviced, a special liquid line drier is required. It is included with replacement compressors.
- R-404A is not compatible with mineral oil so these ice machines use Polyolester oil. Polyolester oil absorbs water very easily. A system opened for service must be re-sealed as soon as possible (15 minutes maximum).
- Special leak detection equipment is required to locate small refrigerant leaks. Usually a leak detector capable of detecting a Halogenated refrigerant or HFC-134a will work. Check with the leak detector manufacturer if in doubt.
- Evacuate to 300 microns.
- Liquid charge the system

Access Valves: To use the access valves:

- Remove the cap from the stem, use a 3/16" allen wrench to check that the valve is CLOSED. The remove the core cap.
- Close the valve and replace the caps when done. The valve must be closed and the caps

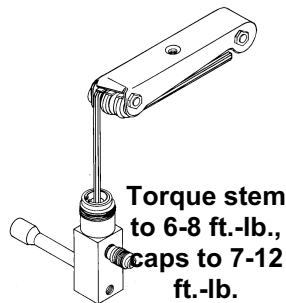

be closed and

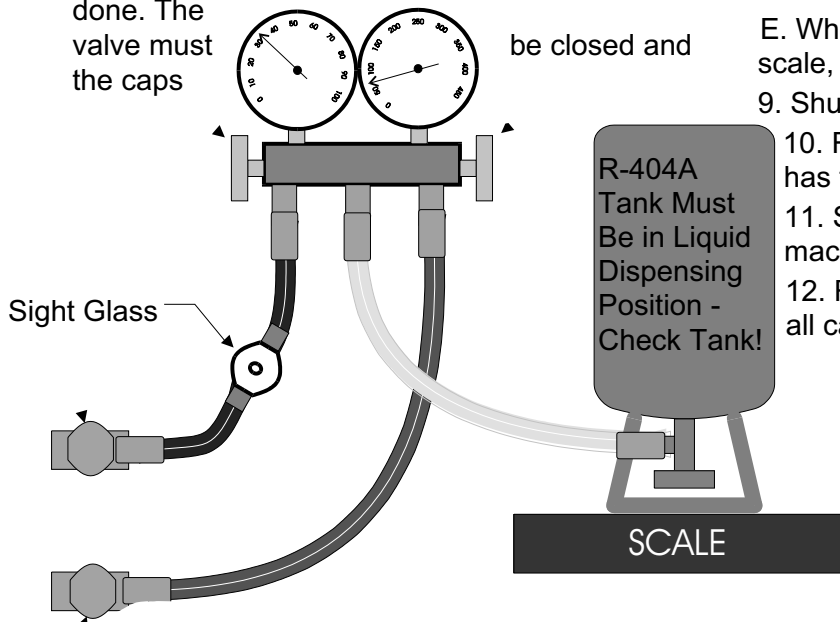

Hose Connection Schematic for Liquid Charging

Instructions for Liquid Charging R-404A

In preparation for charging, the low side hose should have a sight glass, and/or a restricting device (such as a "Charge Faster") installed in it for metering liquid into the low side of the system.

1. After a thorough evacuation shut off the manifold valves and switch off the vacuum pump.
2. Place a drum of R-404A onto an electronic scale.
3. Attach the charging hose to the drum.
4. Open the valve on the drum and purge the charging hose.
5. Zero out the scale.
6. Shut the low side access valve at the ice machine.
7. Open the discharge manifold valve full open.
8. Watch the scale, when the correct charge is shown, shut the manifold valve.

Note: If all of the charge will not "go in" the discharge side:

- A. Shut the discharge access valve at the ice machine.
 - B. Switch the machine on.
 - C. Open the low side access valve at the ice machine.
 - D. Open the low side manifold valve and observe the sight glass to be certain that only gas is flowing into the system.
 - E. When the proper charge is indicated on the scale, shut off the manifold valve(s).
9. Shut off the valve on the refrigerant drum.
 10. Re-open the manifold valves until all liquid has flowed out of the hoses.
 11. Shut the low side access valve on the ice machine.
 12. Remove hoses from ice machine and replace all caps.