

FME800R SERVICE PARTS

This parts list contains the service parts and wiring diagrams for this model. Check the model number in question to be sure that it is applicable to this parts list.

Note: The liquid line filter drier listed in this parts list is designed for this refrigeration system. Premature failure may result if the wrong drier is used.

TABLE OF CONTENTS

Cabinet	2
Refrigeration	3
Water	4
Gearmotor	5
Evaporator	6
Control Box	7
Remote Condenser	8
Wiring Diagrams	9

FME800R SERVICE PARTS

Cabinet Assembly

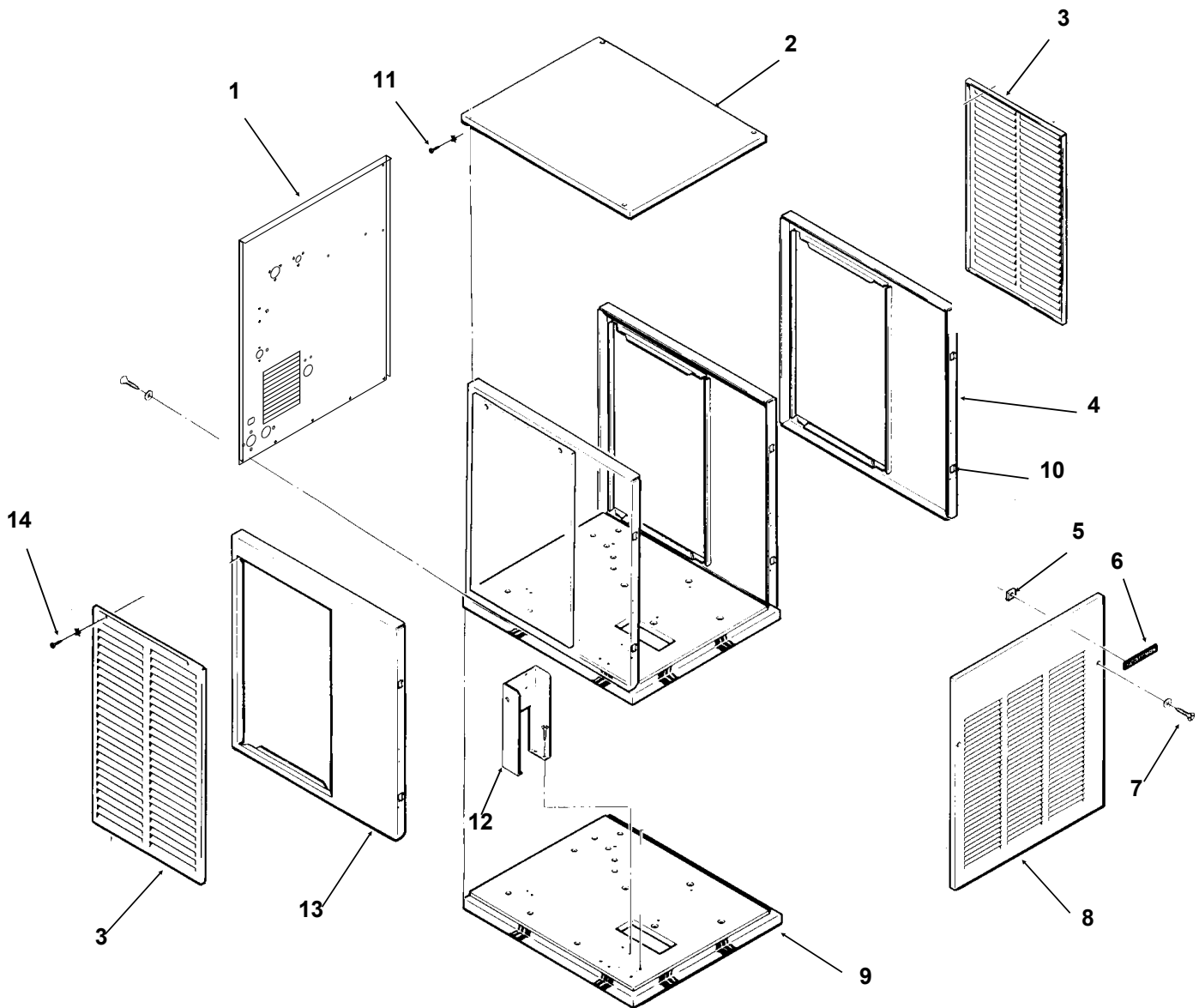

ITEM NUMBER	PART NUMBER	DESCRIPTION	ITEM NUMBER	PART NUMBER	DESCRIPTION
1	A35924-001	Back panel, sandalwood	7	03-1419-22	Screw
	A35924-015	Back panel, gray	8	A33255-001	Front Panel, sandalwood
	A35924-002	Back panel, stainless steel		A33255-015	Front panel, gray
2	A33256-001	Top Panel, sandalwood		A33255-002	Front Panel, S.S.
	A33256-015	Top panel, gray	9	A35890-020	Base Assembly
	A33256-002	Top Panel, S.S.	10	02-0836-00	Catch
3	A32161-001	Service Panel, sandalwood		15-0411-00	Srike
	A32161-015	Service panel, gray		03-1406-04	Nut
	A33946-002	Service Panel, S.S.	11	03-1531-01	Screw
4	A33292-001	Right Side Panel, sandalwood	12	A34039-001	Control Box Support
	A33292-015	Right side panel, gray	13	A32435-001	Left Side Panel, sandalwood
	A33292-002	Right Side Panel, S.S.		A32435-015	Left side panel, gray
5	03-0271-00	Speed Clip		A32435-002	Left Side Panel, S.S.
6	15-0711-01	Emblem, for sandalwood	14	03-1404-12	Screw
	15-0808-03	Emblem, for stainless or gray			

FME800R SERVICE PARTS

Refrigeration System

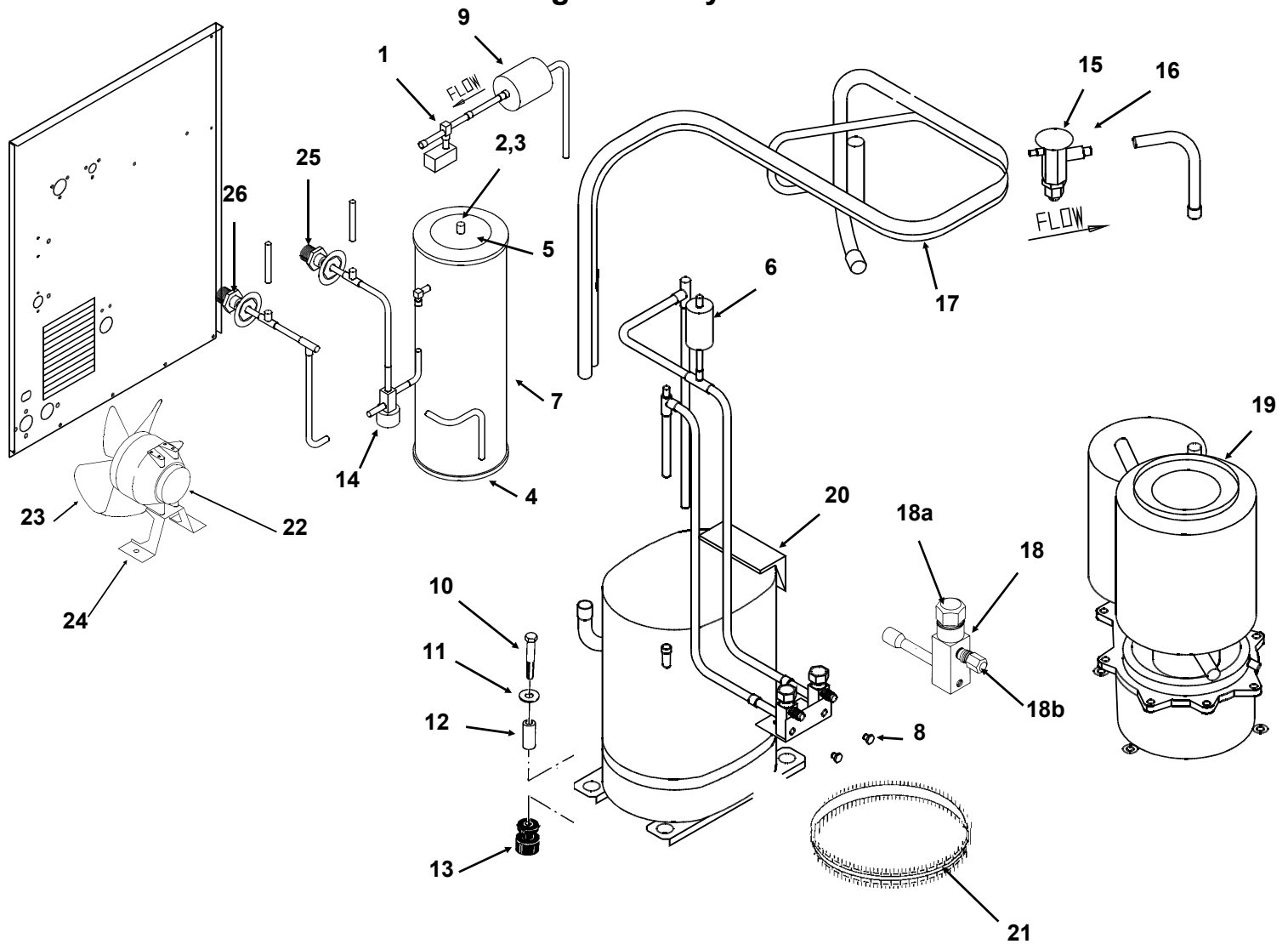

ITEM NUMBER	PART NUMBER	DESCRIPTION
1	12-2274-02*	Liquid line valve or
	12-2135-21*	Liquid line valve
2	03-1406-13	Nut
3	03-1410-06	Washer
4	A32968-001	Receiver Support
5	A31801-002	Receiver Bracket
6	11-0485-21	Hi Pressure Cut Out
7	16-0761-01	Receiver
8	03-1645-01	Cap Screw
9	02-3319-02	Dryer
10	03-1405-20	Cap Screw
11	03-1407-07	Washer
12	18-2200-27	Sleeve
13	18-2200-28	Rubber Grommet
14	11-0422-25	Head Pressure Valve
15	11-0488-21	Thermo Expansion Valve
16	A32961-020	Insulation Kit for TXV
17	A35870-001	Suction Line
18	16-0832-20	Access valve
18a	16-0832-02	Stem cap
18b	16-0832-03	Core cap
19	A33194-020	Evaporator - see page 6
20	18-8721-21	Compressor 115/60/1
	18-8711-50	Overload 115/60/1
21	12-1868-04	Crankcase Htr 115 v
22	12-1576-01	Fan motor
23	18-8708-01	Fan blade
24	A35246-001	Fan motor bracket
25	16-0850-03	Quick connect fitting, 3/8"
26	16-0850-01	Quick connect fitting, 1/2"

* Either solenoid valve may be used.

FME800R SERVICE PARTS

Water System, Water Seal

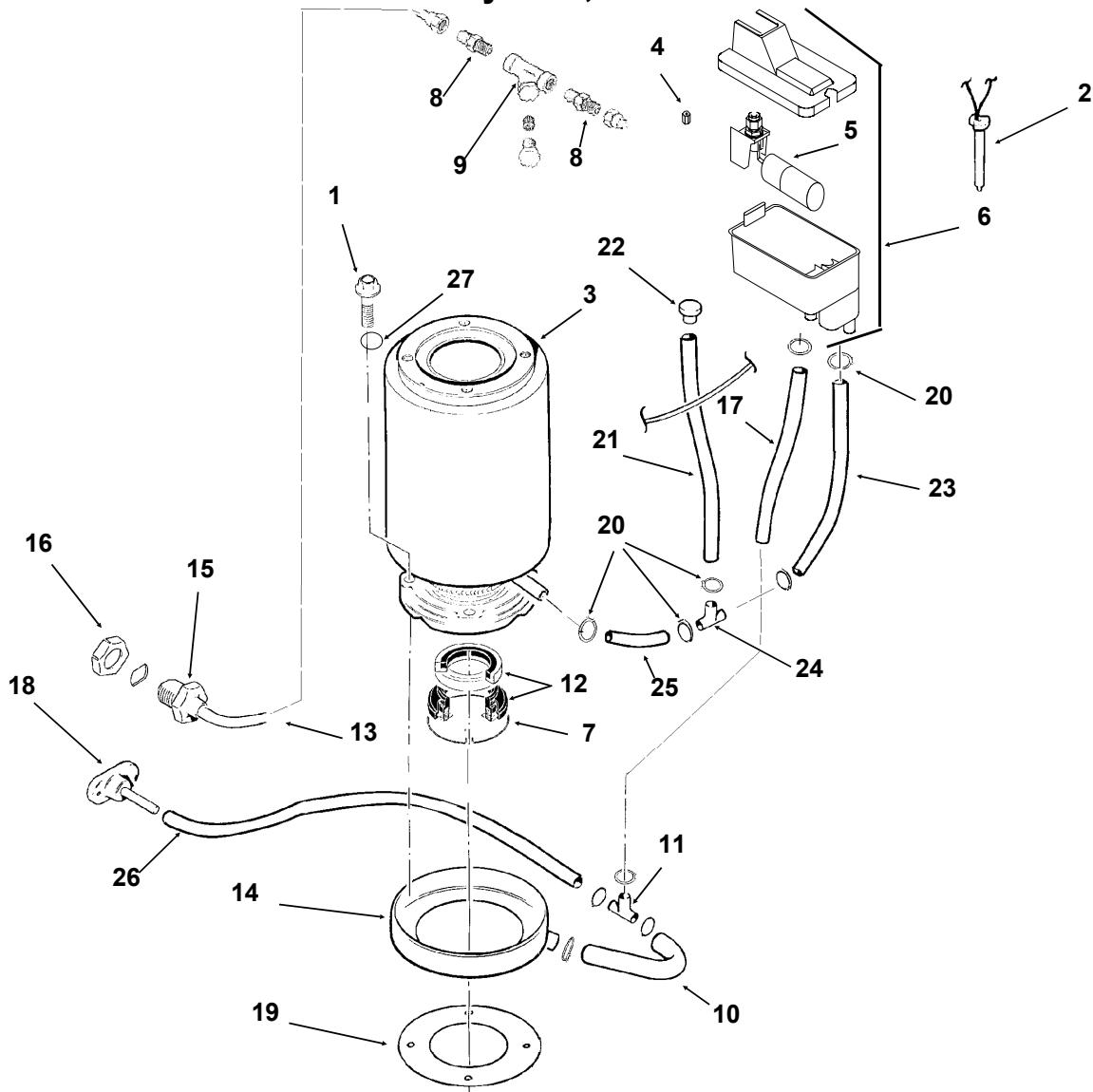

ITEM NUMBER	PART NUMBER	DESCRIPTION	ITEM NUMBER	PART NUMBER	DESCRIPTION
1	03-1420-03	Cap Screw	14	A32050-001	Drip Pan
2	A33101-022	Water Level Sensor	15	A27318-001	Water Inlet Fitting
3	A33194-020	Evaporator	16	03-1394-01	Pal Nut
4	02-3366-03	Valve seat	17	13-0079-03	Res. Overflow, 11" req.
5	02-3366-21	Float valve and seat	18	A34045-001	Drain Casting
6	02-3266-20	Reservoir Assembly	19	13-0704-00	Gasket
	A36078-001	Reservoir bracket (not shown)	20	02-2814-08	Clamps
7	A32777-001	Retaining Ring for Seal	21	13-0674-06	Evap. Drain, 20" req.
8	16-0791-01	Half Union	22	13-0840-01	Plug
9	16-0162-00	Strainer	23	13-0674-06	Evap. Inlet Tube, 10" req.
10	13-0079-03	Tube, 6" req.	24	16-0670-01	Tee
11	16-0670-02	Tee	25	A33203-001	Tube, Preformed
12	02-0929-23	Water Seal	26	13-0079-03	Drain Tube, 27" req.
13	no number	Water inlet tube	27	03-1417-13	Lockwasher

FME800R SERVICE PARTS

Gearmotor

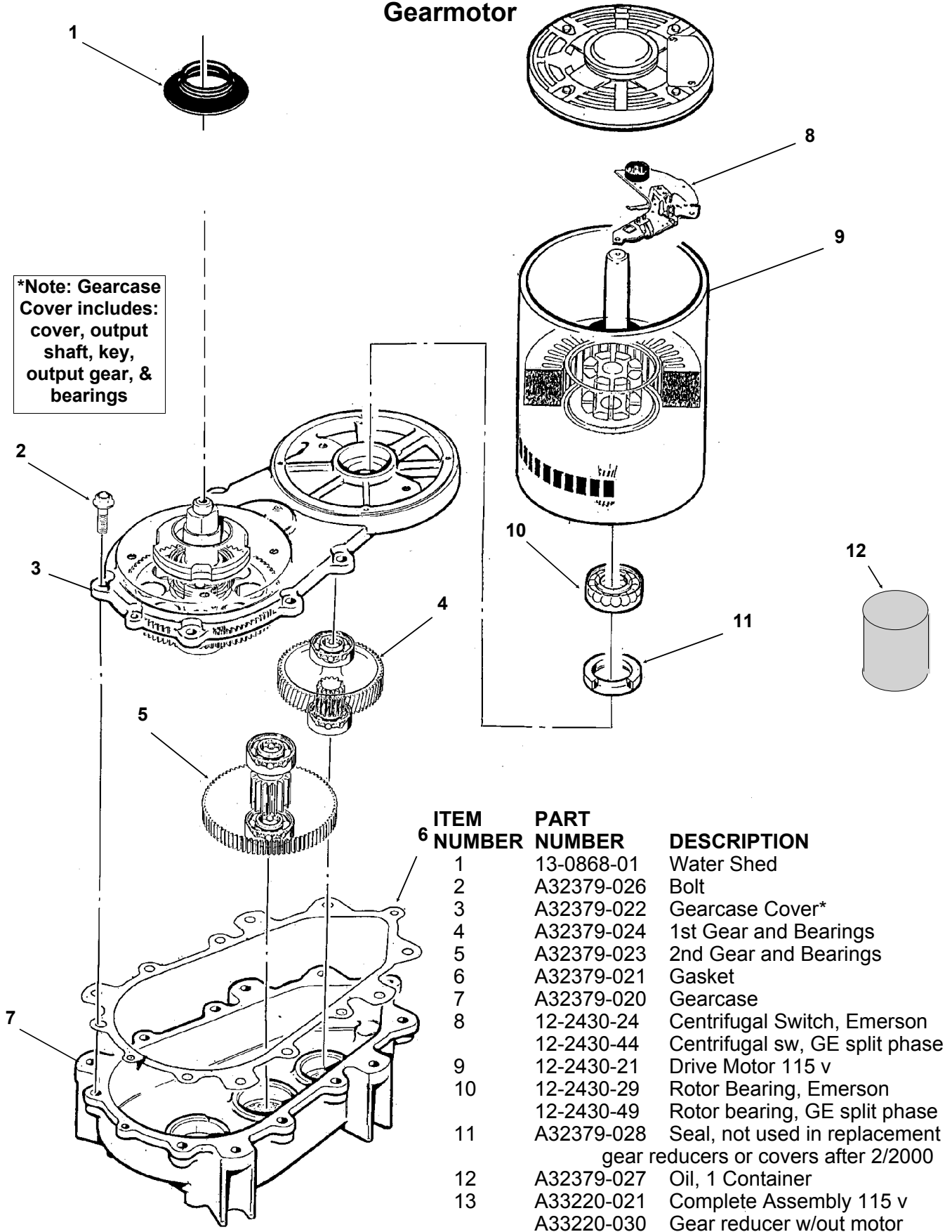

ITEM NUMBER	PART NUMBER	DESCRIPTION
1	13-0868-01	Water Shed
2	A32379-026	Bolt
3	A32379-022	Gearcase Cover*
4	A32379-024	1st Gear and Bearings
5	A32379-023	2nd Gear and Bearings
6	A32379-021	Gasket
7	A32379-020	Gearcase
8	12-2430-24	Centrifugal Switch, Emerson
	12-2430-44	Centrifugal sw, GE split phase
9	12-2430-21	Drive Motor 115 v
10	12-2430-29	Rotor Bearing, Emerson
	12-2430-49	Rotor bearing, GE split phase
11	A32379-028	Seal, not used in replacement gear reducers or covers after 2/2000
12	A32379-027	Oil, 1 Container
13	A33220-021	Complete Assembly 115 v
	A33220-030	Gear reducer w/out motor

FME800R SERVICE PARTS

Evaporator, Bin Controls

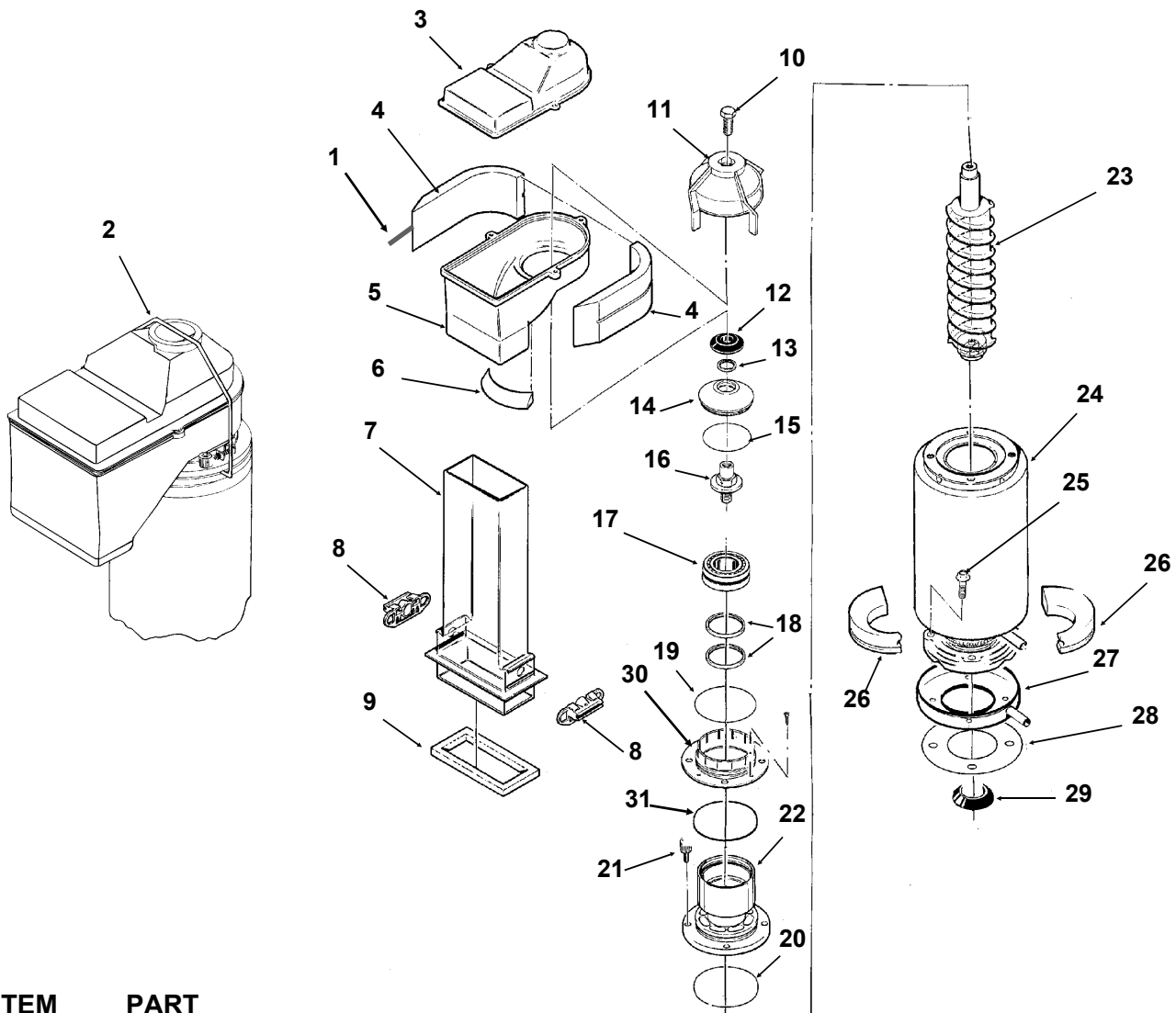

ITEM NUMBER	PART NUMBER	DESCRIPTION
1.	A35419-020	Strap kit
2.	A34969-001	Bail clamp
3.	02-2930-04	Ice Chute Cover
4.	A32963-001	Insulation Top (half)
5.	02-3841-01	Ice Chute Body
6.	A33102-001	Insulation Collar Inside
7.	02-2929-03	Ice Chute Lower
8.	A33117-020	Bin Controls Assy. (set of 2)
9.	A32930-001	Chute Gasket
10.	03-1405-52	Hex Cap Screw
11.	02-3001-01	Ice Sweep
12.	13-0871-01	Water Shed
13.	02-2978-01	Lip Seal
14.	02-3128-20	Breaker Cover
15.	13-0617-54	O-Ring
16.	08-0660-01	Auger Stud
17.	A34559-020	Bearing
18.	02-2977-01	Lip Seal
19.	13-0617-52	O-Ring
20.	13-0617-45	O-Ring
21.	03-1544-08	Soc. Head Screw
22.	A34505-020	Breaker (includes 18 & 19)
23.	A38071-021	Auger
24.	A33194-020	Evaporator
25.	03-1420-03	Cap Screw
26.	A32962-001	Insulation Bot. (half)
	A32962-002	Insulation half
27.	A32050-001	Drip Pan
28.	13-0704-00	Drip Pan Gasket
29.	13-0868-01	Water Shed
30.	02-2916-01	Slotted collar
31.	13-0617-49	O-Ring

FME800R SERVICE PARTS

Control Box

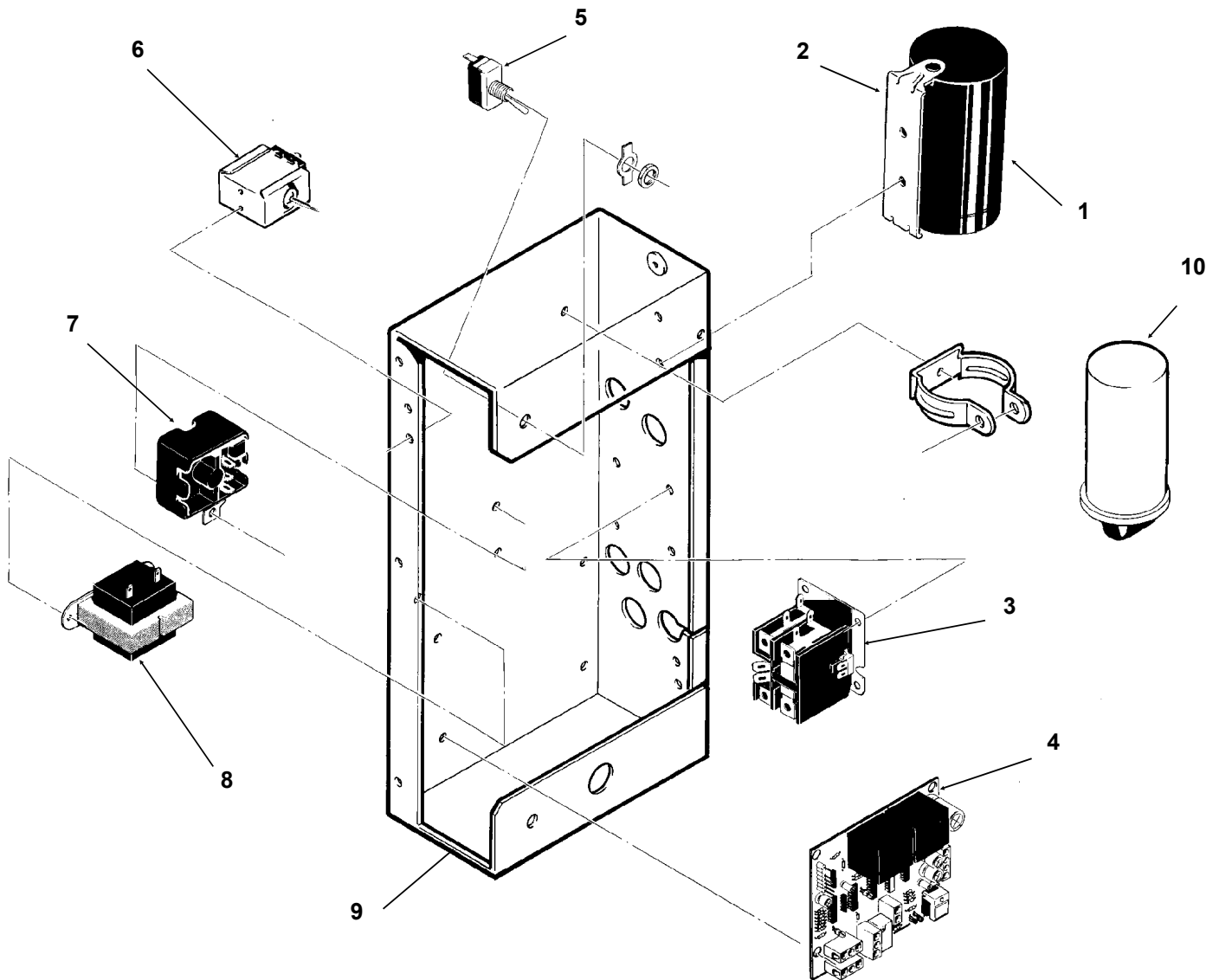

ITEM NUMBER	PART NUMBER	DESCRIPTION	ITEM NUMBER	PART NUMBER	DESCRIPTION
1	18-1901-03	Start Cap	7	18-1903-50	Potential Relay
	18-2200-38	Start Capacitor Cap.	8	12-2285-21	Transformer
2.	18-2200-39	Start Capacitor Bracket	9	no number	Control Box Assy
	03-1638-04	Screw	10	18-1902-45	Run capacitor
	03-1417-15	Lockwasher	NOT ILLUSTRATED		
3.	12-2469-03	Contactora	11.	12-2337-05	2 Pin Plug Assy (Safety Circuit to Circuit Board)
4	A37750-021	Circuit Board	12.	12-2340-01	4 Pin Plug Assy (Transformer to Circuit Board)
5.	12-0426-01	Master Switch	13	A34055-001	Control Box Cover
6.	11-0420-24	Pump Down Control			

FME800R SERVICE PARTS REMOTE CONDENSER

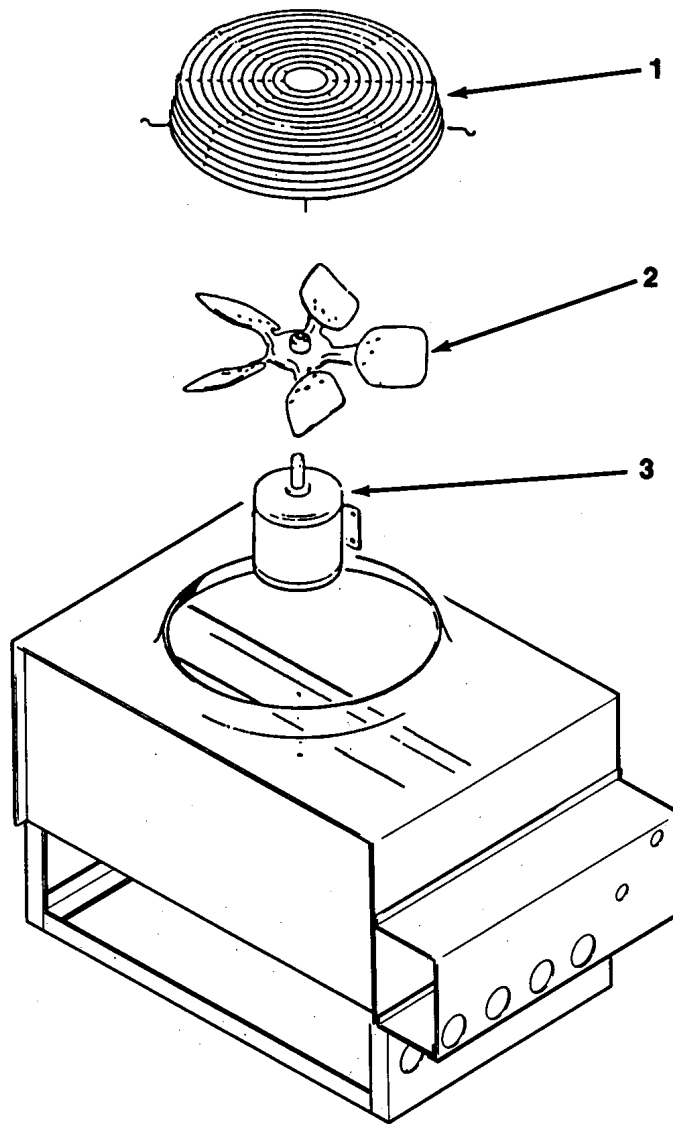

RCE501-1A

ITEM NUMBER	PART NUMBER	DESCRIPTION
1.	02-2618-01	Fan Guard
2.	18-6304-01	Fan Blade
3.	18-6305-01	Fan Motor

For pre-charged line sets:

4	16-1057-01	Female coupling (3/8")
5	16-1057-02	Female coupling (1/2")

ERC101-1A

ITEM NUMBER	PART NUMBER	DESCRIPTION
1	02-3575-01	Fan guard
2	18-8800-01	Fan blade
3	18-8796-01	Fan motor

FME800R SERVICE PARTS Componet Layout Diagram

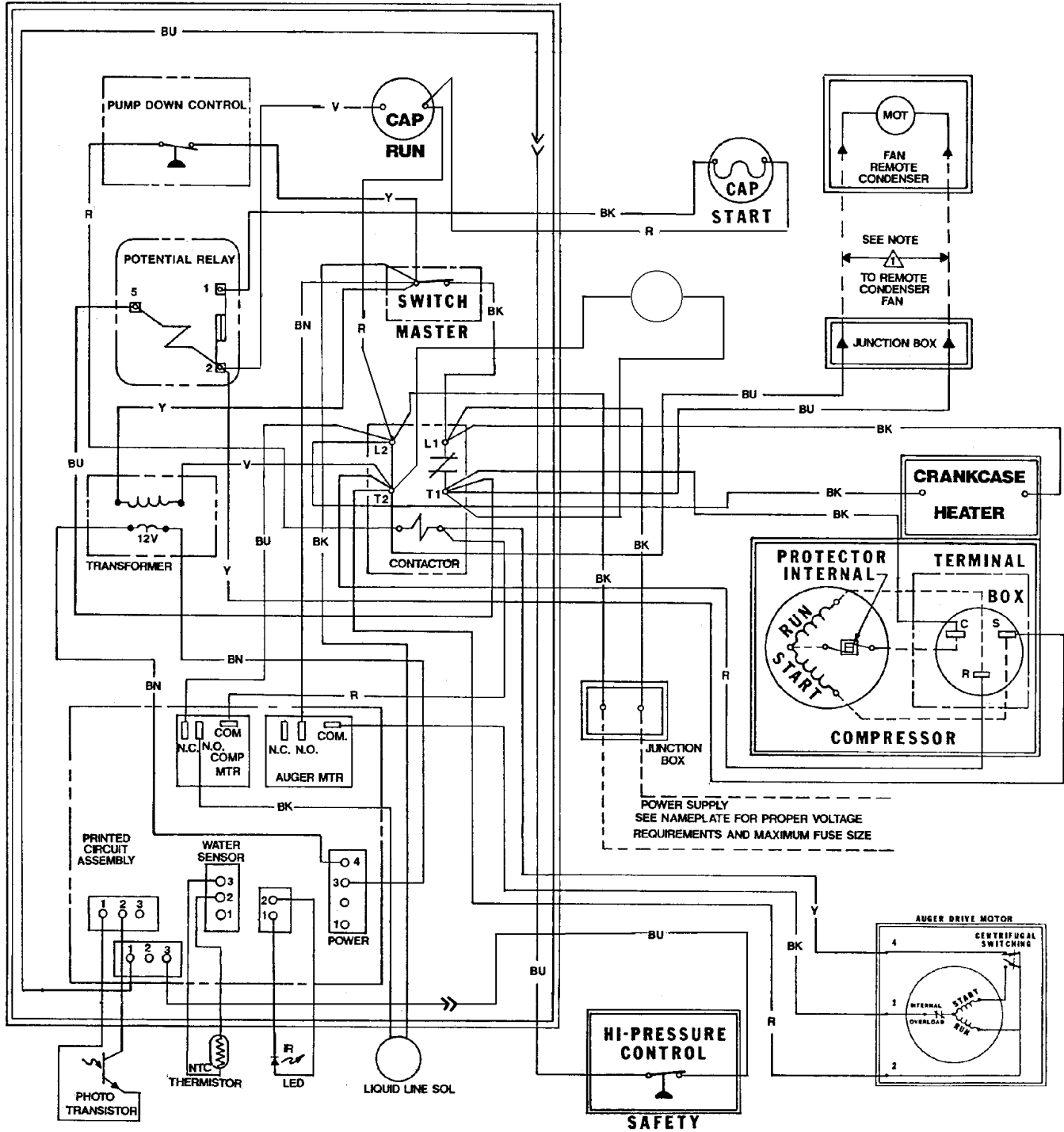

FME800R SERVICE PARTS

Schematic Diagram

